

Axor Urquiola

Bathroom planning



AXOR[®]
hansgrohe



UNIDOMO®

Web: www.unidomo.de

Telefon: 04621- 30 60 89 0

Mail: info@unidomo.com

Öffnungszeiten: Mo.-Fr. 8:00-17:00 Uhr

VIESSMANN

Buderus

 **Vaillant**

WOLF

 **JUNKERS**  **BOSCH**

 **remeha**

 **DAIKIN**

ROTEX

a member of DAIKIN group



-  Individuelle Beratung
-  Kostenloser Versand
-  Hochwertige Produkte

-  Komplettpakete
-  Über 15 Jahre Erfahrung
-  Markenhersteller

Patricia Urquiola's signature is flowing architecture and sensual design.

Her many projects in interior design and product design captivate with their vitality and rich, poetic diversity. Whether it be luxury hotels, showrooms or award-winning furnishings – for Spanish architect and designer Patricia Urquiola, a high level of international recognition is always assured.

The source of her design inspirations is daily life. The Axor Urquiola collection and room concept come together to create harmonious ideas for your personal bathroom – from the architecture right down to the product design.

The entire collection is characterised by smooth transitions, soft shapes and gentle curves. Every element has its own appealing, charming qualities and adds to the overall impression of a warm and welcoming space.

In this way, Axor Urquiola allows you maximum freedom to create very personal living and bathroom scenarios. Through her own very feminine perspective, Patricia Urquiola opens our eyes to an entirely new bathroom experience. Explore the following pages and be inspired by the suggestions for bathroom planning from Axor Urquiola.

Ambiance. The distinctive Axor Urquiola ambiance is created by a fusion of different styles and objects. In this ambiance, personal items find their natural place and help define the unique character of a room.

In the interior design, natural and synthetic materials are combined. With Axor Urquiola the emphasis is on an environment that feels natural and alive. Plants are one important aspect of this environment, and here too personal taste is the deciding factor. Your own desires can be realised down to the smallest detail and your bathroom becomes a mirror of your personality.

Natural filters: Windows are a link to the outside world. In these areas, Patricia Urquiola uses plants, which act as a filter while emphasising the character of the bathroom as a place for retreat. The opposing shower areas, for example, are separated by real plants. These filter zones provide the necessary privacy vis-à-vis the outside and within the room itself. At the same time, they create a natural environment and enhance your quality of life.



My space! Precious personal things, souvenirs from far away, little treasures from an antique market: the Axor Urquiola bathroom thrives on the fusion and mixture of styles and objects. Everything harmonises and integrates with the collection's luxurious elements. Whether traditional, classic, modern or a colourful blend of styles: everything comes together in harmony. With Axor Urquiola, everyone can fulfill their desires and express their own personal style.



Patterns and decoration: The glass surfaces are decorated with a graphic pattern, providing a visual barrier that is rich in contrast. This abstract pattern is also featured on the collection's partition heaters – a design element that creates a sense of consistency and is a recurrent theme in the entire room concept. It inspires your imagination and in a playful manner makes the surfaces more interesting.

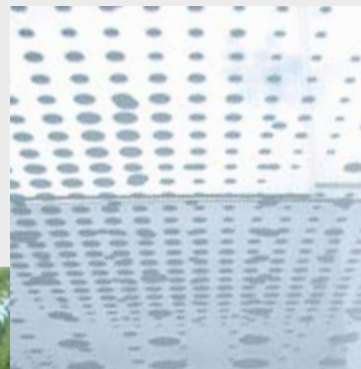

Space. In the Axor Urquiola bathroom, living space and bathroom fuse together to form a comfortable symbiosis of body care, sleep, relaxation and regeneration. What is more, in her bath planning suggestions, Patricia Urquiola introduces an entirely new, pragmatic layout that permits the living space to be more easily adapted to the differing needs of its occupants.

The bathroom can become a place of interaction and communication but also a place of maximum privacy. A separate make-up area, individually arranged wash tables, and showers separated by plants are just a few examples of her unique approach. In this way, she allows for personal freedom, while leaving enough space for harmonious togetherness.



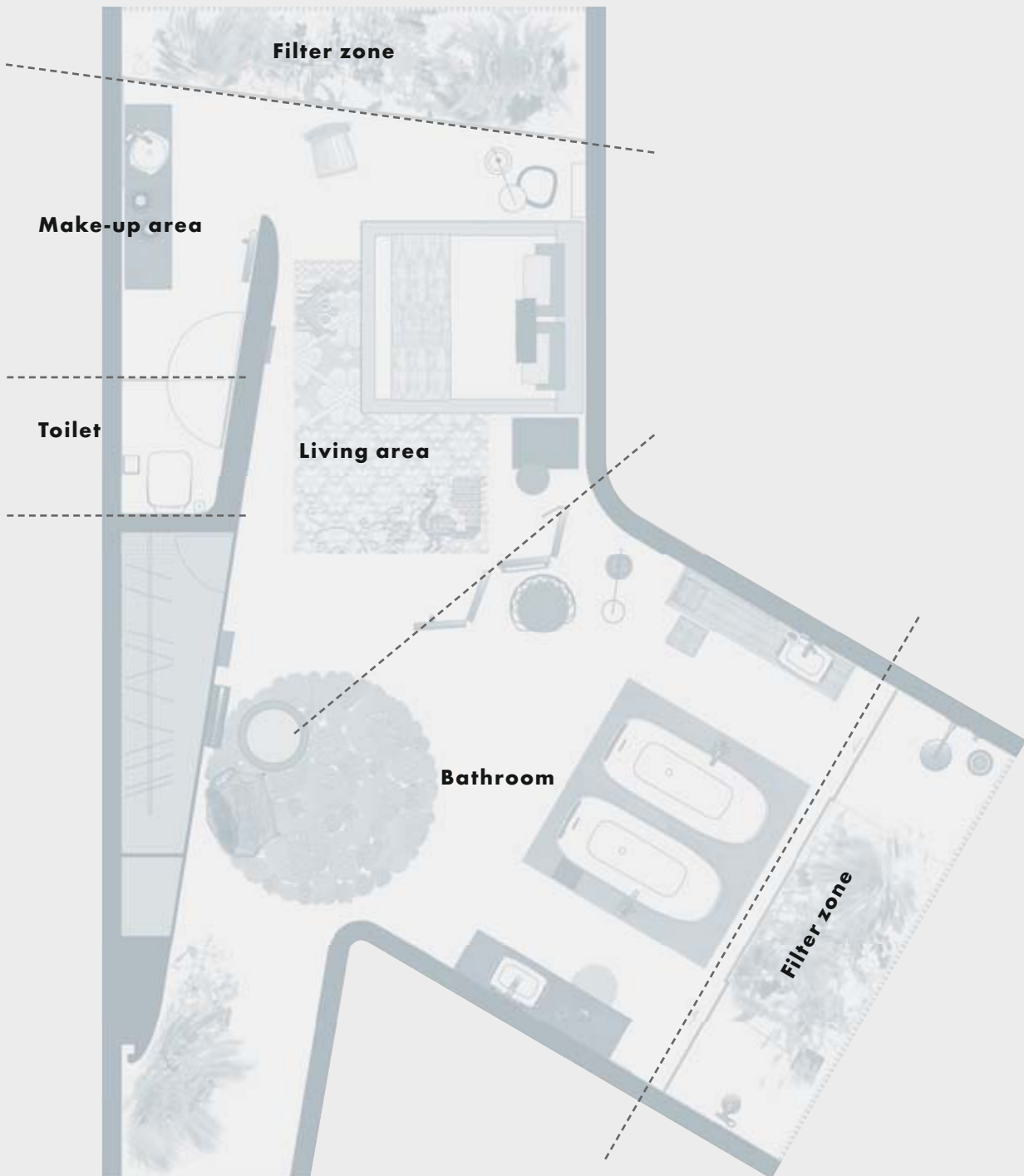

1 The pavilion: Patricia Urquiola's dream bathroom is situated in a pavilion. She designed this bathroom for two people, each with different needs and expectations. The freestanding partition heater separates bathroom and sleeping area. This creates a sense of spatial separation while maintaining an overall feeling of openness and generosity. The layout of the separate make-up area and the opposing wash basins is such that they create zones of privacy that are not entirely separated from one another. This allows space for communication but also individually arranged areas of retreat.



Total area 74.5 m², bathroom area 40 m²

Materials

Wash table

Base for wash table (including make-up area): Solid wooden base made from beams formerly used in construction, e.g. oak, treated with water-repellant sealers. Corian Sienna Brown wash table top. Custom-made wooden bench: solid oak frame, plaited seating surface. Maximum height: 35 cm

Floor coverings

Synthetic resin floor covering, e.g. StoCretec by Sto AG, white (matte) (www.sto.com). In the shower area: concrete tiles, e.g. Beton White Lappato. Preincision 45 x 90 cm, manufactured by Apavisa Porcelánico; floor-level shower system with shadow gap drainage, e.g. Poresta Slot, manufactured by Illbruck (www.illbruck-sanitaertechnik.com). In the bath tub area: 4 Déchirer 1200 x 1200 mm ceramic tiles, manufactured by Mutina, designed by Patricia Urquiola, (www.mutina.it)

Walls

Walls: simple smooth-surfaced plaster, white (RAL 9010). Rounded wall: exposed concrete. Combined slatted/glass wall: vertical wooden structure with horizontal reinforcement, slatted structure made from weather-resistant solid wood such as larch/Douglas fir; interior all-glass floor-to-ceiling wall. Individual sliding elements. Glass partition wall in the shower area: frameless all-glass elements (toughened safety glass), mounted into sliding brackets, e.g. Sprinz Motion 700 system. Floor-to-ceiling mirror mounted on the wall, with fine edges, positioned to one side of the wash table. Toilet partition: all-glass swinging door (thoughed safety glass).

Lighting

Basic lighting is provided via indirect illumination of the filter zone. All lights can be dimmed. Rounded wall: back-lit by vertical fluorescent lamps in the entrance area; accent lighting with Davide Groppi Ozen S 300 surfaced spotlights, white matte. Pendant lamps in the wash table area: antiques, e.g. from demosmobilia/Chiasso Switzerland. Pendant lamps in the make-up area/wash table area: Flos Chasen pendant lamps designed by Patricia Urquiola.

Furniture

Bed: Lowland, manufactured by Moroso, designed by Patricia Urquiola. Side tables: Shanghai Tip, manufactured by Moroso, designed by Patricia Urquiola; Fjord, manufactured by Moroso, designed by Patricia Urquiola. Lens, manufactured by B & B Italia, designed by Patricia Urquiola; Fat Fat-Lady Fat, FF 66, manufactured by B & B Italia, designed by Patricia Urquiola. Chair: Tropicalia, manufactured by Moroso, designed by Patricia Urquiola. Frilly, manufactured by Kartell, designed by Patricia Urquiola. Chair and stool: Re-trouvé, manufactured by Emu, designed by Patricia Urquiola. Free-standing mirror with metal frame, custom-made.

Miscellaneous decor

Rug: Crochet, manufactured by Paola Lenti; designed by Patricia Urquiola and Eliana Gerotto; Sardinia Peacock Light, manufactured by Moroso, designed by Patricia Urquiola

Axor Urquiola products and complementary products

Make-up area

1 x basin mixer for wash bowls	# 11034000
1 x round wash basin	# 11301000
1 x Flowstar	# 52100000

Wash table 1

1 x 3-hole basin mixer, wall-mounted	# 11042000
1 x basic set	# 10303180
1 x rectangular wash basin, table-mounted	# 11300000
1 x Flowstar	# 52100000

Wash table 2

1 x single lever basin mixer, wall-mounted	# 11026000
1 x basic set for single lever basin mixer	
Wall-mounted version	# 10902180
1 x rectangular wash basin, wall-mounted	# 11302000
1 x Flowstar	# 52100000
1 x soap dish	# 42433000

Bath tub

2 x thermostat bath mixer, floor-mounted	# 11422000
2 x basic set for thermostat bath mixer, floor-mounted	# 10452180
2 x bath tub	# 11440000

Shower 1

1 x concealed thermostat	# 11731000
1 x iBox universal basic set	# 01800180
2 x shut-off valve	# 11960000
2 x basic set for shut-off valve	# 15974180
1 x Porter unit	# 11626000
1 x Raindance Royale overhead shower	# 28420000
1 x shower arm for Raindance Royale	# 27410000
1 x single hook	# 42401000

Shower 2

1 x shower column	# 11901000
-------------------	------------

Heater

2 x partition heater ("Clouds" mirror/pattern)	# 42510000
2 x partition heater ("Clouds" pattern)	# 42500000
1 x swivel mirror for heater	# 42513000
1 x single hook for heater	# 42515000
1 x bath towel holder for heater	# 42516000
4 x basic set for partition heater	# 42512180
1 x heater, wall-mounted	# 42501000
1 x single hook for heater	# 42515000

Toilet

1 x toilet brush holder	# 42435000
1 x roll holder	# 42436000
1 x Keramag 500 toilet	# 202100
1 x bath towel holder	# 42460000

More than just a bathroom. A closer look at the pavilion reveals that it actually contains three complete bathrooms of different sizes. These range from a small, integrated bathroom to a large, symmetrical bathroom layout. Regardless of the size and floor plan, the design elements that are typical of Patricia Urquiola, such as the fusion of different styles and objects, the green filter zones and the personal privacy retreats, are always preserved.

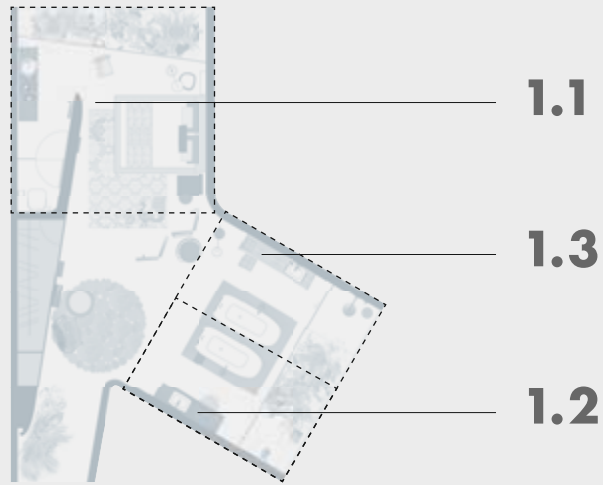

1.1

Cosy and compact: The integrated bathroom is a sophisticated fusion of living room and bathroom. Reminiscent of the early 20th century: the wash table in the sleeping area and the shower in the garden. The green filter zone forms the boundary between the living area and the outside world. This filter zone is where the shower is located. The toilet is laid out as a completely separate unit. All in all, this is a deliberate effort to rethink the bathroom once again: it is not just a functional room, but part of the total space for personal wellbeing, which also includes the natural world.



Bathroom area 15 m²

1.2

Well-proportioned layout: If you draw a line through the bath tub area of the pavilion bathroom, an independent wellness area is created. The bath tub is positioned opposite to the plants in the filter zone, to allow you to cast your eyes on a green space while you take a bath. The shower area is also integrated into this green space. Next to the wash table a single heated partition element is mounted onto the wall. In this way, the partition element performs the function of a towel warmer and an attractive visual barrier.

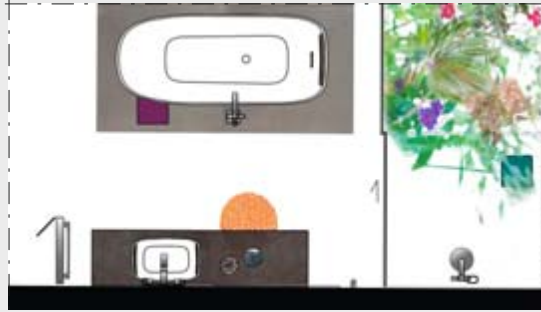

Bathroom area 12.5 m²

1.3

Harmonious symmetry: This layout captivates with its symmetrical design that contains two different personal areas. The two wash tables are placed opposite one another. This allows both of you to have your own space, which can be arranged according to your personal preferences. On one side, the wash basin and single lever mixer are mounted onto the wall; on the opposite side, the wash bowl is placed on a table and combined with a 3-hole mixer. The shower areas are also set up opposite one another and are separated by the natural filter.



Bathroom area 25 m²

2

A space for wellbeing: With this planning approach, Patricia Urquiola illustrates how her design ideas can be realised in a classic, right-angled bathroom. Thanks to the floor-to-ceiling window, the room is flooded with daylight. In combination with the plants a friendly, natural ambiance is created, reminiscent of a lovingly decorated conservatory. The bath tub is separated from the resting and sleeping area by a partition and offers a relaxing view onto the green space. In the entrance area opposite the bed, there is a highly practical walk-in wardrobe.

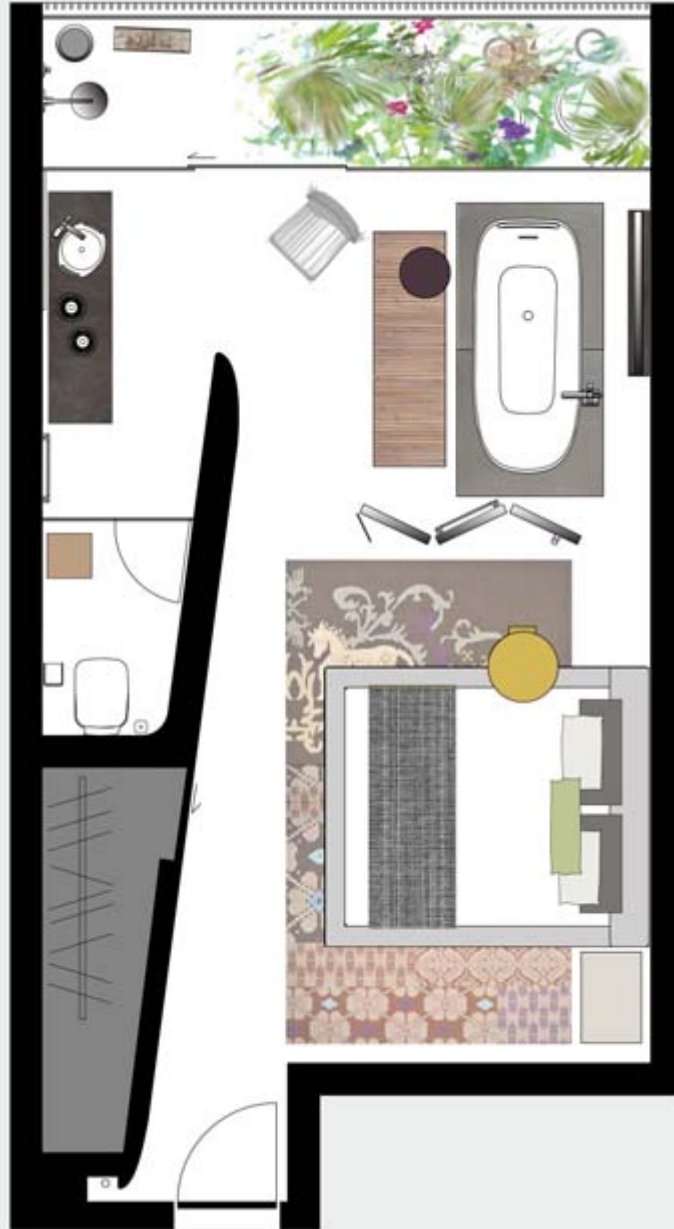

Total area 37 m², bathroom area 16 m²



Materials

Wash table. Base for wash table: solid wooden base made from beams formerly used in construction, e.g. oak, treated with water-repellant sealers. Corian Sienna Brown wash table top.

Floor covering Royal Mosa Black & White porcelain stoneware, white, 900x900 mm, white grouting. Shower area: floor must be slip-proof, drain channel integrated into the floor. In the bath tub area: 2 Déchirer 1200x1200 mm ceramic tiles, manufactured by Mutina, designed by Patricia Urquiola (www.mutina.it).

Walls Rounded wall/toilet back wall/wardrobe: Surface: imi-Beton imitation concrete composite material boards (www.imi-beton.com). Cupboard sliding doors. Shower: Royal Mosa Black & White porcelain stoneware, white, 900x900 mm, white grouting. Combined slatted/glass wall: vertical wooden structure with horizontal reinforcement, slatted structure made from weather-resistant solid wood such as larch/Douglas fir. Interior all-glass floor-to-ceiling wall. Individual sliding elements. Glass partition wall in the shower area: frameless all-glass elements (toughened safety glass), mounted into sliding brackets, e.g. Sprinz Motion 700 system. Floor-to-ceiling mirror mounted on the wall. Toilet partition: all-glass swinging door (laminated safety glass). Wardrobe interior: stainless steel clothes rail.

Lighting Basic lighting is provided via indirect illumination of the filter zone. All lights can be dimmed. Rounded wall: back-lit by vertical fluorescent lamps in the entrance area. Accent lighting, Davide Groppi Ozen S 300, white matte; pendant lamps in the wash table area: Flos Chasen pendant lamps designed by Patricia Urquiola.

Furniture Bed: Lowland, manufactured by Moroso, designed by Patricia Urquiola. Side tables: Shanghai Tip, manufactured by Moroso, designed by Patricia Urquiola.

Chair: Frilly, manufactured by Kartell, designed by Patricia Urquiola.

Miscellaneous decor Rug: Sardinia Peacock Light, manufactured by Moroso, designed by Patricia Urquiola.

Axor Urquiola products and complementary products

Wash table

1 x wash basin mixer for wash bowls	# 11034000
1 x round wash basin	# 11301000
1 x Flowstar	# 52100000
1 x toothbrush tumbler	# 42434000

Bath tub

1 x thermostat bath mixer, floor-mounted	# 11422000
1 x basic set for thermostat bath mixer, floor-mounted	# 10452180
1 x bath towel holder	# 42460000
1 x bath tub	# 11440000

Shower

1 x concealed thermostat	# 11731000
1 x iBox universal basic set1	# 01800180
2 x shut-off valve	# 11960000
2 x basic set for shut-off valve	# 15974180
1 x Porter unit	# 11626000
1 x Raindance Royale overhead shower	# 28420000
1 x shower arm for Raindance Royale	# 27410000
1 x single hook	# 42401000

Heater

2 x partition heater ("Clouds" mirror/pattern)	# 42510000
1 x partition heater ("Clouds" pattern)	# 42500000
1 x swivel mirror for heater	# 42513000
1 x single hook for heater	# 42515000
1 x bath towel holder for heater	# 42516000
3 x basic set for partition heater	# 42512180

Toilet

1 x toilet brush holder	# 42435000
1 x roll holder	# 42436000
1 x Keramag 500 toilet	# 202100

3

Effective use of space: This bathroom is not only suitable for private homes, but is also a perfect solution for a luxurious hotel room. Directly in the entrance area there is a wardrobe and a separate toilet with wash basin. The balcony with plants introduces light into the room. The wall-mounted wash basin with accessories and the wooden bench underneath provide ample space for all personal items.

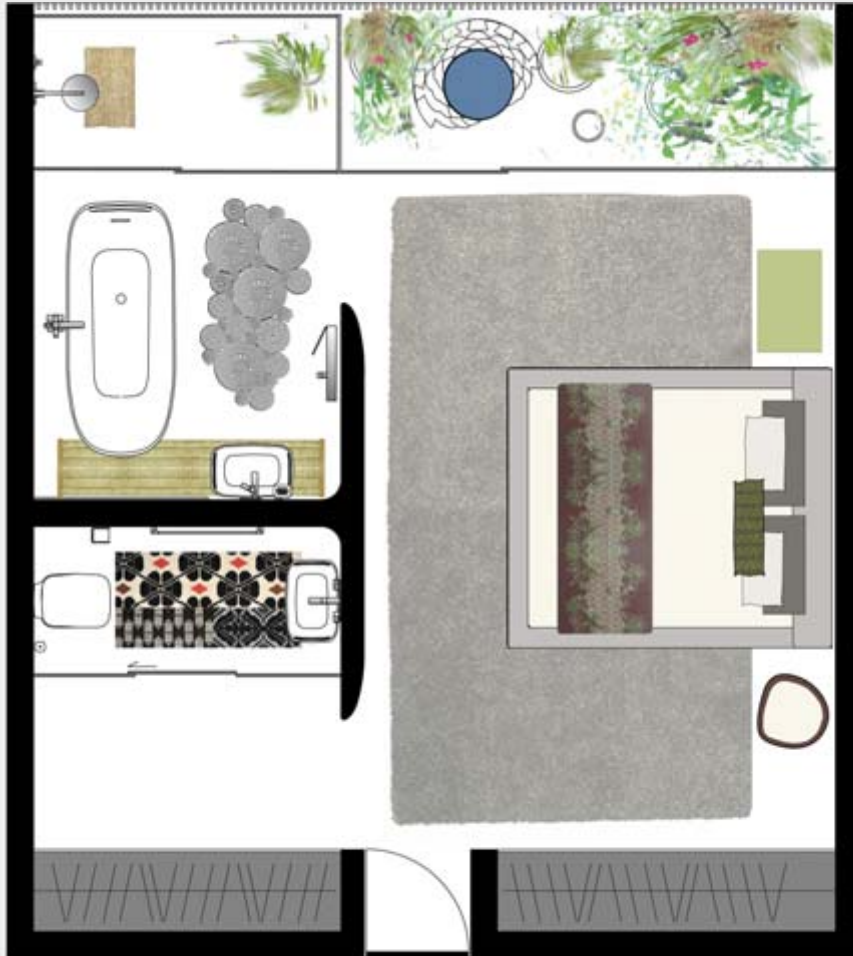

Total area 41 m², bathroom area 11 m²



Materials

Wash table Custom-made wooden bench: solid oak frame, plaited seating surface. Max. height: 35 cm.

Floor coverings Ardex Pandomo Floor, cement-based primer coating, white (www.ardex-pandomo.de). Shower, bath tub and wash table areas: Graniti Fiandre, Taxos Extra 600 x 600 mm, white, white grouting.

Walls Interior walls: textured plaster, white RAL 9016. Rounded wall: Pandomo Wall, light grey. Shower: Graniti Fiandre, Taxos Extra 600 x 600 mm, white, white grouting. Interior sliding door system, MST5 5000 Vario, manufactured by Dorma (www.dorma-glas.de). Wardrobe: Burg Kama bathroom furniture RC 40 series. Combined slatted/glass wall: slatted structure, aluminum U-profiles mounted onto single frame. Powder-coated surface, white RAL 9016. Interior all-glass floor-to-ceiling wall. Individual sliding elements. Glass partition wall in the shower and toilet areas: Interior sliding door system, MST5 5000 Vario, manufactured by Dorma (www.dorma-glas.de).

Lighting Basic lighting is provided via indirect illumination of the filter zone and the entrance area. All lights can be dimmed. Accent lighting with Davide Groppi Ozen S 300 surfaced spotlights, white matte.

Furniture Bed: Lowland, manufactured by Moroso, designed by Patricia Urquiola. Side tables: Shanghai Tip, manufactured by Moroso, designed by Patricia Urquiola. Fjord, manufactured by Moroso, designed by Patricia Urquiola. Seat: Retrouvé, manufactured by Emu, designed by Patricia Urquiola.

Miscellaneous decor Rugs: Aperlada, manufactured by Paola Lenti, designed by Patricia Urquiola and Eliana Gerotto. Crochet, manufactured by Paola Lenti, designed by Patricia Urquiola and Eliana Gerotto. Sardinia Flower Light, manufactured by Moroso, designed by Patricia Urquiola.

Axor Urquiola products and complementary products

Wash table

1 x single lever basin mixer, wall-mounted	# 11026000
1 x basic set for single lever basin mixer Wall-mounted version	# 10902180
1 x rectangular wash basin, wall-mounted	# 11302000
1 x Flowstar	# 52100000
1 x soap dish	# 42433000

Bath tub

1 x thermostat bath mixer, floor-mounted	# 11422000
1 x basic set for thermostat bath mixer, floor-mounted	# 10452180
1 x bath tub	# 11440000

Shower

1 x concealed thermostat	# 11731000
1 x iBox universal basic set	# 01800180
2 x shut-off valve	# 11960000
2 x basic set for shut-off valve	# 15974180
1 x Porter unit	# 11626000
1 x Raindance Royale overhead shower	# 28420000
1 x shower arm for Raindance Royale	# 27410000

Heater

1 x heater, wall-mounted	# 42501000
1 x swivel mirror for heater	# 42513000

Toilet

1 x 3-hole basin mixer, wall-mounted	# 11042000
1 x basic set for 3-hole basin mixer, wall-mounted	# 10303180
1 x rectangular wash basin, wall-mounted	# 11302000
1 x Flowstar	# 52100000
1 x toilet brush holder	# 42435000
1 x roll holder	# 42436000
1 x Keramag 500 toilet	# 202100

Inspiration. Patricia Urquiola developed different interior design concepts for the Axor Urquiola bathroom. The plants in particular are a characteristic of quality of life and a real indicator of well-being. As filter zones, they create a smooth transition to the urban outside world and introduce subtle separations within the room. Yet in this restructured living space, the feeling of a generous, open environment and a warm, welcoming atmosphere remain dominant. Vital areas for privacy and retreat are created, which simultaneously provide space where you may communicate and enjoy one another's company.

The following examples will show you how to use the key elements of Patricia Urquiola's dream bathroom in a flexible and creative way, and entirely in accordance with your own personal preferences – even in pre-existing floor plans.



A: One key element in the Axor Urquiola bathroom is the filter zones, which can be created by glass walls. If the bathroom doesn't offer floor-to-ceiling windows, a light well with plants can also act as a natural filter zone.

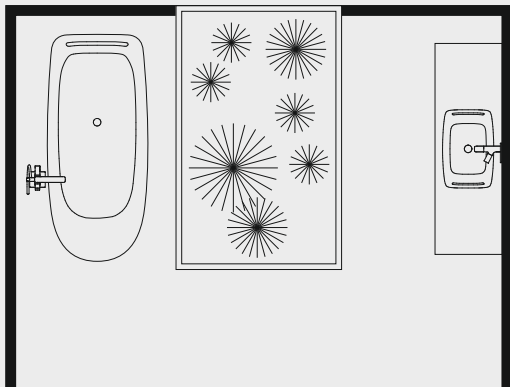

B: Gently curved walls enhance the harmonious, vibrant overall impression of the bathroom. Even in rectangular floor plans it is possible to create round, soft wall shapes as a design element, by the use of drywall for instance.

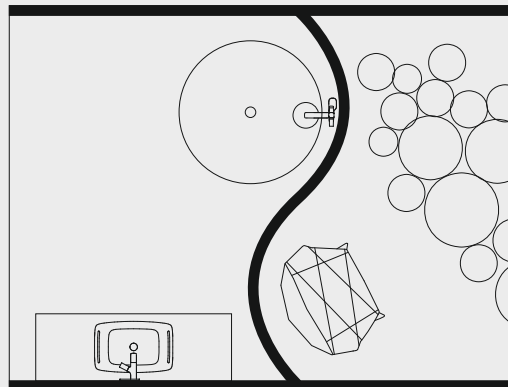

C: In this concept, the diagonally opposing placement of the wash basins on a central table offers a practical solution to the fulfillment of different expectations. This allows each of you the freedom to arrange your wash table area according to your own preferences.

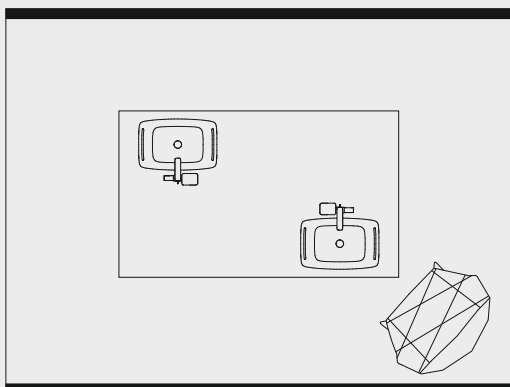

D: The collection's partition system lets you structure space and separate individual areas according to your preferences. For example, in an existing bathroom the partition system makes it possible to separate the toilet from the rest of the bathroom.

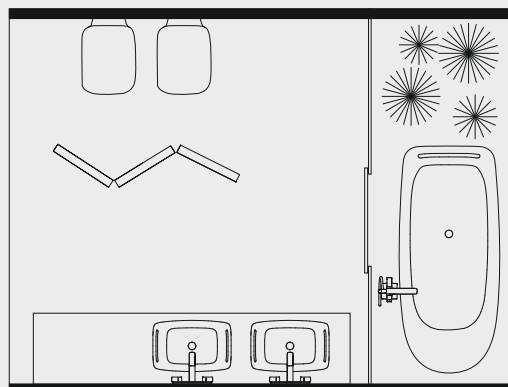

Partition heater. In ancient Japan, partitions were used not only to provide shelter from the wind but also to structure rooms. In 18th century Europe, they were used primarily as a visual barrier. The Axor Urquiola partition is much more than just a visual barrier or a room-structuring element. The individual partition elements can be upgraded with many functional accessories such as a single hook, a towel holder or a swivel mirror, according to your needs and desires.

The elements can be used as modules and are available with a heating function. A unique combination of partition, heater, mirror and a place to hang your clothes. Whether mounted on the wall or free standing in the room, these elements offer a unique and intelligent solution for any floor plan. In addition to the modular partition elements, the collection also offers a wall-mounted heater.



Partition and warm wall in one: When joining several single elements together, a partition is created which restructures the entire room. For reasons of stability, a free-standing installation requires at least two partition elements to be joined at a 120° angle. For larger rooms, additional elements can be added to the partition heater, increasing the heat capacity.



Partition with heating function! A single partition element can be placed at a right angle to the wall by means of a wall fastening. The connections are installed in the floor. Apart from the interesting architectural effect, this set-up adds structure and a visual barrier even in small bathrooms.



Classic wall-mounted version. Thanks to its slimness, the wall-mounted heater is a perfect solution for smaller bathrooms and niches. The heater is connected through the wall. You can enhance the functionality of the heater by installing a hook for towel and bath robe as well as a swivel mirror.



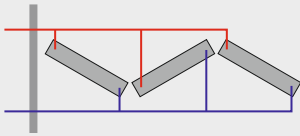

Partition heater (free standing)

The partition heater is a partition with a heating function. It consists of individual elements (for reasons of stability at least 2 elements are required) which have to be positioned together to form a 120° angle. The elements consist of a standard panel radiator with connections underneath spaced 300 mm apart, and facing panels with hole pattern # 42500000 or a single-sided mirror # 42510000. The customer must install a separate thermostat with a flexible, wall-mounted control to regulate the heater.

Please note: The partition heater is installed on the unfinished floor on a specific basic set (# 42512180). The basic set has to be placed in exactly the right position. It accommodates the supply and return pipes and

directs them to the right place in the heater elements. The basic set is cast into the plaster floor, which is covered with tiles or another suitable floor surface. When using an element with a mirror (single-sided), the heating plate has to be installed in the correct position since the mirror paneling cannot be changed once installed.

1. Heating installation

The heater elements are operated with a supply and return system and are connected to the same circuit as the bathroom heating. The connections are made through the floor and the necessary supply and return pipes must be planned and installed in the correct place. Ideally, the several heating plates are connected to a heating circuit in parallel or via a distributor block each for supply and return. This ensures that the temperature and heat capacity of all the individual heater elements of the partition is identical. The regulation is accomplished directly through the dis-

tributer block or, in the case of parallel connected heaters, by means of a central thermostat in the supply system. The connections are located 3/8" to the right and left of the heater element. At low temperature operation, the partition heater can be used as a towel warmer and as a supplement to under-floor heating; the flow temperature should be 50°, in which case the heat capacity is approx. 390 Watt per element (measured according to EN 442). When operating the heater at a flow temperature of approx. 75°, the heat capacity is approx. 729 Watt per element (measured according to EN 442). The operating pressure of the heater system is max. 10 bar. The max. operating temperature is 90°.

Please note: The heat capacity is an approximate value only (measured according to EN 442), and the actual heating effect in the room is dependent on the size of the room, the properties of the walls and how often the room is aired. The minimum distance to the floor is adjustable. The total height of the basic set is 360 mm and it offers an adjustment range

of approx. 120 mm to compensate for floor construction.

2. Supply pipes

All standard pipe materials are connected directly to the heater by means of compression fittings, Eurokonus fitting with max. SW32.

3. Accessories

Swivel mirror	# 42513000
single hook	# 42515000
bath towel holder	# 42516000



1 Position basic set on the unfinished floor (for reasons of stability at least 2 basic sets are required), drill and screw them to the floor.



2 Connect the supply and return pipes to the basic sets according to planning and connection type.



3 Lay plaster and tiles.



4 Installation of the partition heater elements.



5 Joining of the heater elements.



6 Installing the accessories on the front panels. Installing the fastening element for the towel holder.



7 Mounting the single hook.

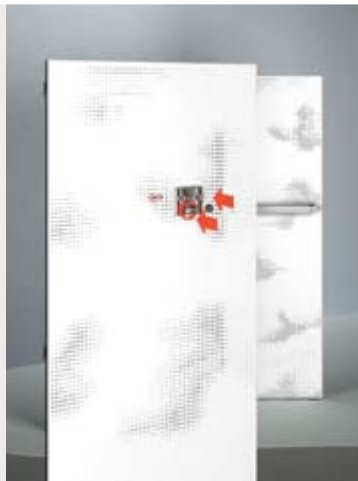

8 Installing the fastening element for the single hook.

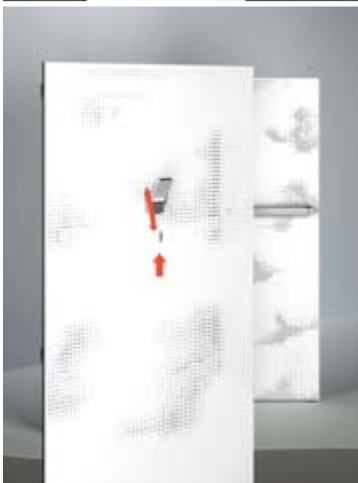

9 Mounting the towel hook.



10 Installing the accessories on the front panels. Hanging the front panels.



11 Installation of the swivel mirror: Detaching the side panel. Mounting the swivel mirror.



12 Hanging the front panel.

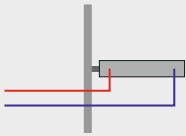

Partition heater (wall-mounted)

The wall-mounted partition heater is a partition element with a heating function. It consists of a single element which is attached to the wall at its narrow side.

The element is composed of a standard panel radiator connected from below, and facing panels with hole pattern (# 42500000) or a single-sided mirror (# 42510000). The heater is regulated via a separate thermostat with a flexible, wall-mounted control.

Please note: The wall-mounted partition heater is installed on the unfinished floor on a specific basic set (# 42512180). The basic set has to be placed in exactly the right position. It accommodates the supply and return pipes

and directs them to the correct place in the heater elements. The basic set is cast into the plaster floor, which is covered with tiles or another suitable floor surface. When using an element with a mirror (single-sided), the heating plate has to be installed in the correct position since the mirror panelling cannot be changed once installed.

1. Heating installation

The heater elements are operated with a supply and return system and are connected to the same circuit as the bathroom heating. The connections are made through the floor and the necessary supply and return pipes must be planned and installed in the correct location. The heater is regulated by means of a central thermostat in the supply system. The connections are 3/8" to the right and left of the heater element. In low temperature operation, the partition heater can be used as a towel warmer and as

a supplement to under-floor heating; the flow temperature should be 50°, in which case the heat capacity is approx. 390 Watt per element (measured according to EN 442). When operating the heater at a flow temperature of approx. 75°, the heat capacity is approx. 729 Watt per element (measured according to EN 442). The operating pressure of the heater system is max. 10 bar. The max. operating temperature is 90°.

Please note: The heat capacity is an approximate value only (measured according to EN 442), and the actual heating effect in the room is dependent on the size of the room, the properties of the walls and how often the room is aired. The minimum distance to the floor is adjustable. The total height of the basic set is 360 mm and it offers a range of adjustment of approx. 120 mm to compensate for floor construction.

2. Supply pipes

All standard pipe materials are connected directly to the heater by means of compression fittings, Eurokonus fitting with max. SW32.

3. Accessories

Swivel mirror	# 42513000
single hook	# 42515000
bath towel holder	# 42516000



1 Position basic set (1 basic set) on the unfinished floor, drill and screw it to the floor. Connect the supply and return pipes to the basic sets according to planning and connection type.



2 Lay plaster and tiles.



3 Installation of the partition heater element. Installation of the wall fastening element.



4 Hanging the front panel.

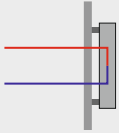

Heater (wall-mounted)

The wall-mounted heater element consists of a standard panel radiator connected from below in the centre, and facing panels with hole pattern. The heater is regulated via a thermostat; we recommend a designer thermostat in a matching stainless steel or chrome finish.

1. Heating installation

The heater elements are operated with a supply and return system and are connected to the same circuit as the bathroom heating. The connection is made through the wall and the necessary supply and return pipes must be planned and installed in exactly the correct location. The connections are 2 x G 1/2" with supply on the right, return on the left, and 50 mm boss spacing. At low temperature operation, the partition heater can be used as a towel warmer and as a supplement to under-floor heating; the flow temperature should be 50°, in which case the heat capacity is approx. 525 Watt (measured according to EN 442). When operating the heater at a flow temperature of approx. 75°, the heat capacity is approx. 982 Watt (measured according to EN 442). The operating pressure of the heater system is max. 10 bar. The max. operating temperature is 90°. The minimum distance to the floor is 150 mm.

Please note: The heat capacity is an approximate value only

(measured according to EN 442), and the actual heating effect in the room is dependent on the size of the room, the properties of the walls and how often the room is aired.

2. Supply pipes

All standard pipe materials are connected directly to a standard thermostat by means of compression fittings, Eurokonus fitting with max. SW32.

3. Accessories

The heater can be equipped with a swivel mirror (# 42513000) which must be ordered separately. It can be mounted on the right or left side of the heater. Accessories can be screwed onto the facing panel. The available accessories are a 465 mm bath towel holder (# 42516000) and a single hook (# 42515000). The accessories are mounted into pre-defined position holes on the facing panel.



1 Position the wall rails and screw them onto the wall.



2 Mount the fastenings for the heater.



3 Mount the heater element. Connect to supply and return of the thermostat valve.



4 Hanging of the facing panel.

**Partition heater and partition
(free-standing and wall-mounted)**

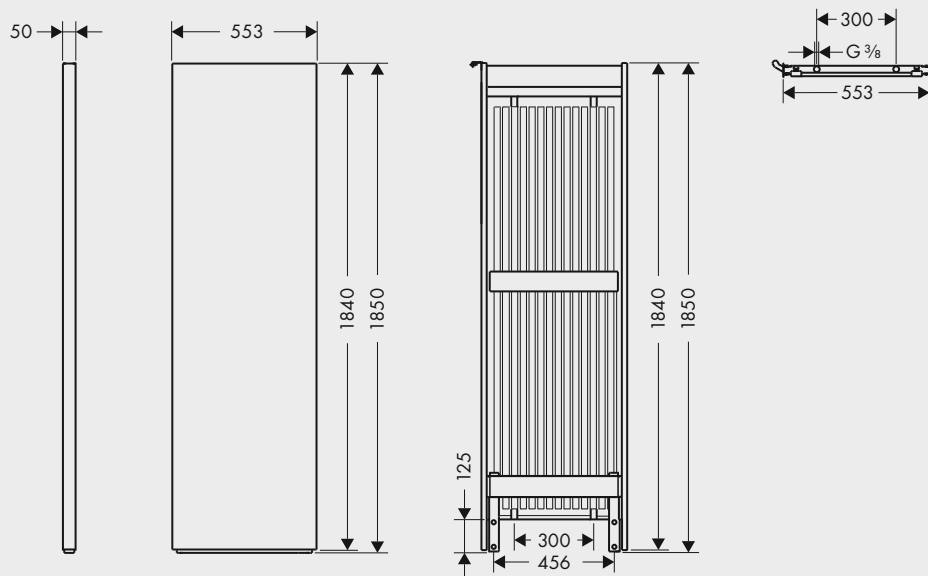

Heater (wall-mounted)

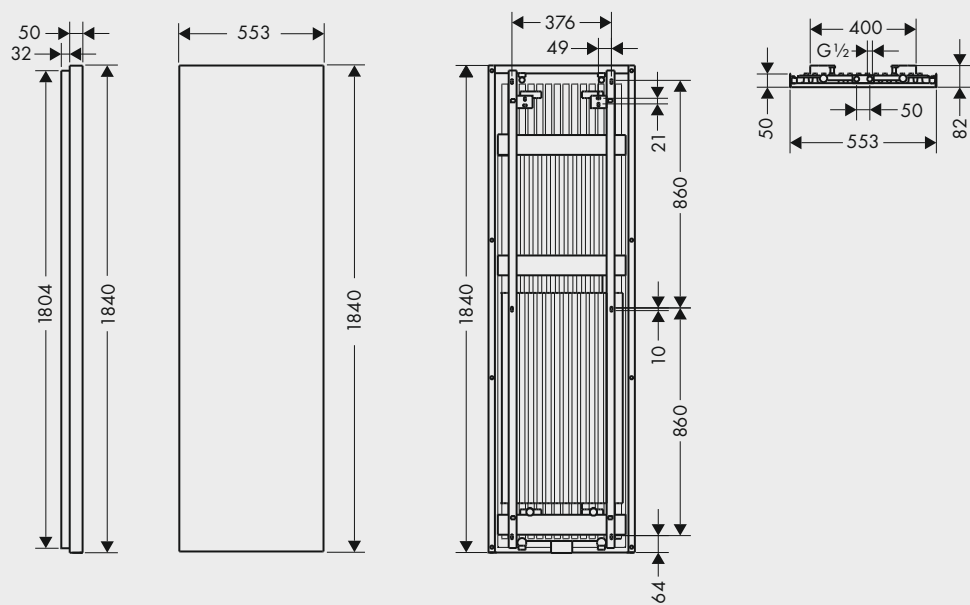



Partition heater
"Clouds" pattern,
1840 x 553 x 50 mm (H,W,D),
heat capacity approx. 730 W
(75/65/20°) EN 442
42500000*
basic set # 42512180



Partition heater
mirror (single-sided)/"Clouds" pattern,
1840 x 553 x 50 mm (H,W,D),
heat capacity approx. 730 W
(75/65/20°) EN 442
42510000*
basic set # 42512180



Partition
"Clouds" pattern,
1840 x 553 x 50 mm (H,W,D)
42505000*
basic set # 42512180



Partition
mirror (single-sided)/"Clouds" pattern,
1840 x 553 x 50 mm (H,W,D)
42511000*
basic set # 42512180



Basic set for partition
and partition heater
42512180
Wall fastening for partition
(not shown)
42514000



Swivel mirror
1840 x 241 x 13 mm (H,W,D)
42513000



Single hook
42515000



Bath towel holder
outer dimension 465 mm
42516000

* for reasons of stability, at least 2 partition elements
are required for a free-standing installation



Heater, wall-mounted
"Clouds" pattern,
1840 x 553 x 82 mm (H,W,D),
heat capacity approx. 980 W
(75/65/20°) EN 442
42501000



Swivel mirror
1840 x 241 x 13 mm (H,W,D)
42513000



Single hook
42515000



Bath towel holder
outer dimension 465 mm
42516000



Wall fastening for partition
42514000



Bathroom Architecture: Studio Urquiola, Milan; **Photography:** Alessandro Paderni / Eye studio, Udine;
Styling: alessandramonti studio, Como; **Set building:** Ideaeffe; **Special thanks to:** Ivica Dilber (Credo Centar),
Dipl. Ing. (FH) Arkas Förstner (fön,design_), Architect A.V.B. Joop Gerards, Dipl. Architekt ETH/SIA Daniel Lischer
(Lischer Partner Architekten Planer AG), Dipl.-Ing. Innenarchitekt BDIA Christian Wadsack (HOFMANN + WADSACK),
Friedhelm Weinkopf (WEINKOPF GmbH)

United Kingdom – Hansgrohe · Units D1 and D2 · Sandown Park · Trading Estate · Royal Mills · Esher · Surrey · KT10 8BL
Tel. +44 (0) 1372 465 655 · Fax +44 (0) 1372 470 670 enquiries@hansgrohe.co.uk · www.hansgrohe.co.uk

Cyprus – Hansgrohe · Middle East & Africa Limited · Artemisia Buisness Center
14 Charalambou Mouskou Office 201 · CY-2015 Strovolos · Nicosia · Cyprus
Tel. +357 22 441370 · Telefax +357 22 441374 · nicosia@hansgrohe.com · www.hansgrohe-mea.com

India – Hansgrohe India (pvt.) Ltd. · Office Nos. 601 - 604 · Sky Station Viman Nagar · 411 016 Pune · Maharashtra
India Tel. +91 20 6625 9595 · info@hansgrohe.in

Portugal – Hansgrohe · Rua Antoine de Saint Exupéry Alapraia · P-2765-043 Estoril
Tel. +351 21 4667110 · Fax +351 21 4667119 · hansgrohe@jrb.pt · www.hansgrohe.com

Singapore – Hansgrohe Pte. Ltd. · 69 Mohamed Sultan Road · Singapore 239015
Tel. +65 6884 5060 · Fax +65 6884 5070 · info@hansgrohe.com.sg · www.hansgrohe.com.sg

Japan – Hansgrohe · Japan K.K. Ono Bldg. 6F · 2-15-21 Takanawa · Minato-ku · Tokyo 108-0074 Japan
Tel. +81 3 5424-1950 · Fax +81 3 3449-9651 · info@hansgrohe.co.jp · www.hansgrohe.co.jp

USA – Hansgrohe Inc. · 1490 Bluegrass Lakes Parkway · USA Alpharetta · GA 30004
Tel. +1 770 360 9880 · Fax +1 770 360 9887 · info@hansgrohe-usa.com · www.hansgrohe-usa.com

AXOR
hansgrohe

Axor-Hansgrohe AG · Postfach 1145 · D-77757 Schiltach · Telefon +49 7836 51-0
Telefax +49 7836 51-1300 · info@axor-design.com · www.axor-design.com



en-UK-Axor Urquiola Badplanung · Form-Nr. 84 120699 · 05/09/16.1 · Printed in Germany · Printed on 100% chlorine free bleached paper · Subject to technical alterations and colour differences due to the printing process.