



6 m



Sanicondens® Clim Mini

Klein, leise und stark – praktisch und schnell montiert



PRODUKTVORTEILE

- Sicherheitssystem
- Einfach zu kontrollieren: transparenter Tank
- Kompakte Minipumpe, zur unauffälligen Montage

UNIDOMO®



TECHNISCHE DATEN

Geräuschpegel	21 dB(A)
Mögliche Anschlüsse	Klimageräte bis zu 10 kW
Ø Einlass	16 mm
Ø Abflussrohr	8-10 mm
Max. Wassereintritts-temperatur	35 °C
Max. Ansaugleistung (zwischen Sensorblock und Pumpe)	2 m
Stromversorgung	220-240 V
Netzfrequenz	50 Hz
Max. Leistungsaufnahme	22 W
Artikel-Nr.	0040
GTIN	33088115012193

ABMESSUNGEN

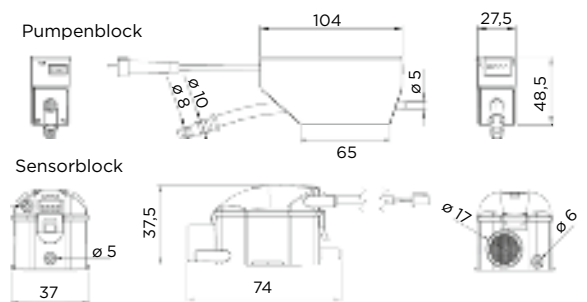

Saughöhe in Metern (A)	Förderhöhe in Metern (B)	Förderstrecke in Metern (C)			
		5	10	20	30
0	1	10,4	9,1	8,3	7,3
	2	8,9	7,8	7,0	6,4
	3	7,9	7,1	6,3	5,8
	4	7,0	6,0	5,3	4,9
1	1	8,9	8,3	7,5	5,9
	2	7,8	7,3	6,7	6,1
	3	6,9	6,7	5,7	5,4
	4	5,9	5,5	4,9	4,4
1,5	1	7,8	7,6	6,9	6,5
	2	7,1	6,6	6,2	5,7
	3	6,5	5,7	5,1	4,8
	4	5,5	4,8	4,2	3,9

Tabelle mit den Förderleistungen in Liter/Stunde (± 10 %)

PUMPENKENNLINIE

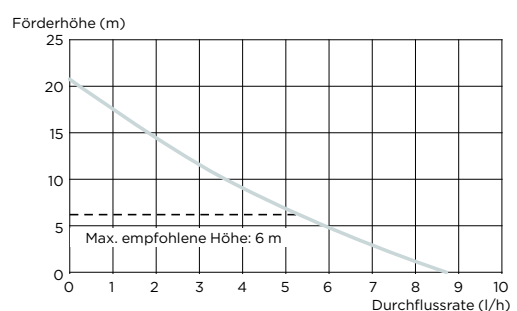



UNIDOMO®

Web: www.unidomo.de

Telefon: 04621- 30 60 89 0

Mail: info@unidomo.com

Öffnungszeiten: Mo.-Fr. 8:00-17:00 Uhr

VIESMANN

Buderus

 **Vaillant**

WOLF

 **JUNKERS**  **BOSCH**

 **remeha**

 **DAIKIN**

ROTEX

a member of DAIKIN group



-  Individuelle Beratung
-  Kostenloser Versand
-  Hochwertige Produkte

-  Komplettpakete
-  Über 15 Jahre Erfahrung
-  Markenhersteller