

# SUPERPLAN

- exklusives, elegantes Design
- aus KALDEWEI Stahl-Emaille
- Ablaufdeckel nahezu bündig in die Duschkfläche integriert (nur in Kombination mit den Ablaufgarnituren KA 90)

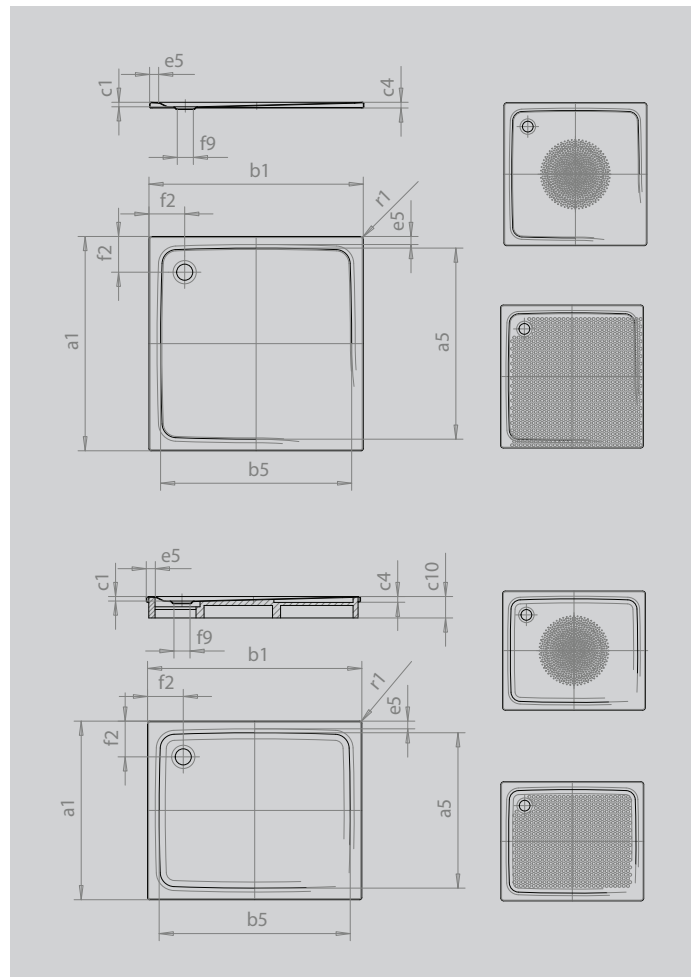

Abbildung ähnlich



 UNIDOMO®

SECURE<sup>+</sup>

Modell		399
Äußere Länge	$a_1$	1200 mm
Innere Länge	$a_5$	1070 mm
Äußere Breite	$b_1$	1200 mm
Innere Breite	$b_5$	1070 mm
Tiefe Innen	$c_1$	25 mm
Randhöhe	$c_4$	32 mm
Höhe mit Wannenträger	$c_{10}$	120 mm
Höhe mit Wannenträger extraflach	$c_{16}$	49 mm
Randbreite	$e_{10} ; e_5$	50; 50 mm
Durchmesser Ablaufloch	$f_9$	Ø 90 mm
Abstand Wannenrand bis Mitte Ablaufloch	$f_2 ; f_3$	200; 200 mm
Äußerer Radius	$r_1$	12 mm
Nettogewicht		38 kg
Antislip Durchmesser		Ø 588 mm
Vollantislip		1060 x 1105 mm
SECURE PLUS		Vollflächig

**KALDEWEI**



**UNIDOMO®**

**Web:** [www.unidomo.de](http://www.unidomo.de)

**Telefon:** 04621- 30 60 89 0

**Mail:** [info@unidomo.com](mailto:info@unidomo.com)

**Öffnungszeiten:** Mo.-Fr. 8:00-17:00 Uhr

**VIESMANN**

**Buderus**

 **Vaillant**

**WOLF**

 **JUNKERS**  **BOSCH**

**OR remeha**

 **DAIKIN**

**ROTEX**

a member of DAIKIN group



-  Individuelle Beratung
-  Kostenloser Versand
-  Hochwertige Produkte

-  Komplettpakete
-  Über 15 Jahre Erfahrung
-  Markenhersteller