



---

## Ihr Online-Fachhändler für:

---



**Buderus**

- Kostenlose und individuelle Beratung
- Hochwertige Produkte
- Kostenloser und schneller Versand

- TOP Bewertungen
- Exzelerter Kundenservice
- Über 20 Jahre Erfahrung



**E-Mail: [info@unidomo.de](mailto:info@unidomo.de) | Tel.: 04621 - 30 60 89 0 | [www.unidomo.de](http://www.unidomo.de)**

# GB125 18-60kW V5, MC110

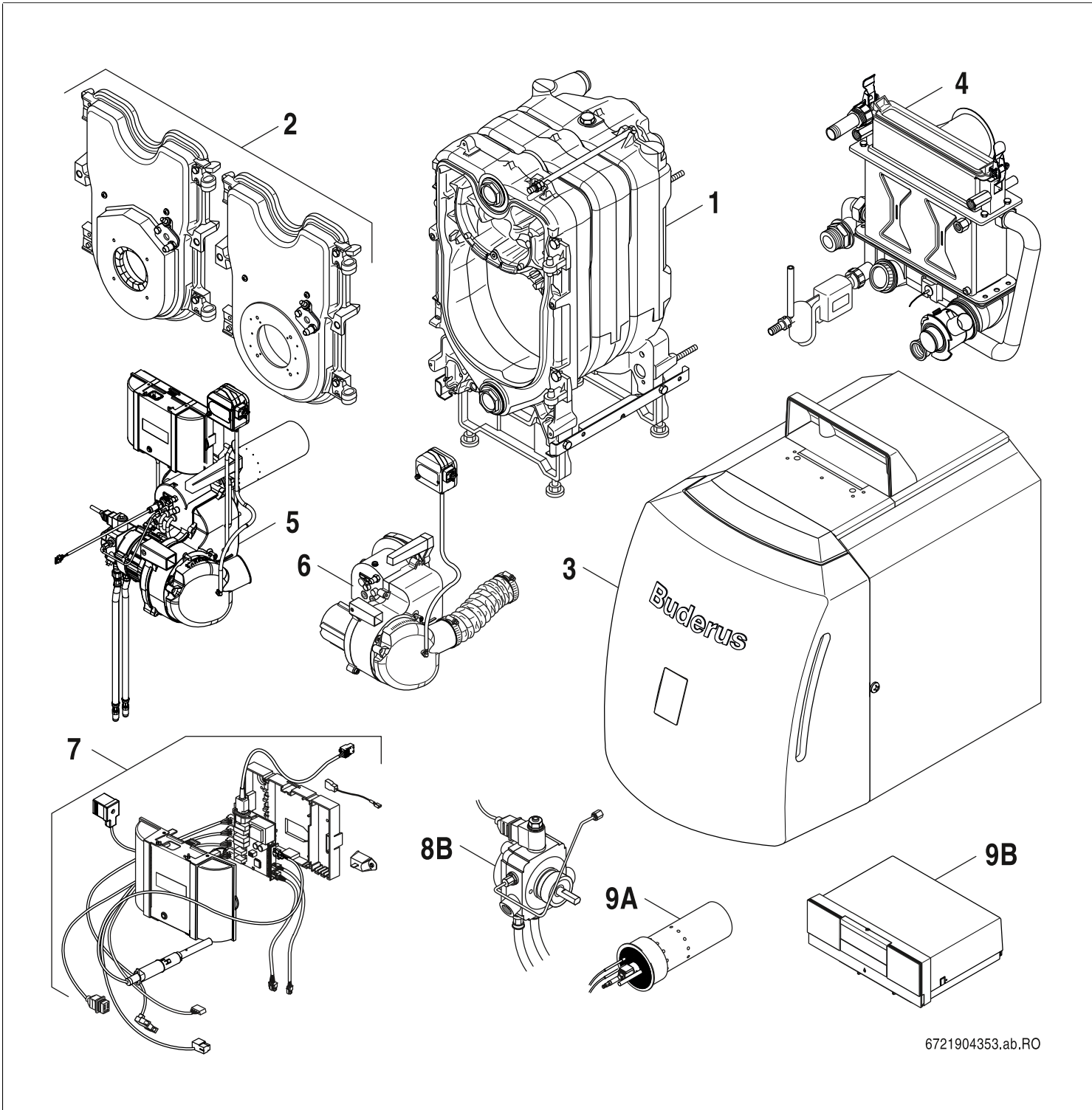

6721904353.ab.RO



**[de] Wichtige Hinweise zur Installation/Montage**

Die Installation/Montage muss durch eine für die Arbeiten zugelassene Fachkraft unter Beachtung der geltenden Vorschriften erfolgen.

**[en] Important notes on installation/assembly**

The installation/assembly must be carried out by a qualified contractor, following these instructions and in compliance with the applicable regulations.

**[fr] Instructions importantes pour l'installation/le montage**

L'installation/le montage doit être effectué(e) par un spécialiste qualifié pour les opérations concernées et dans le respect de la présente notice et des prescriptions applicables.

**[bg] Важни указания във връзка с инсталацията/монтажа**

Инсталацията/монтажът трябва да се извършва от лицензиран за работите специалист в съответствие с настоящото ръководство и с приложимите разпоредби.

**[cs] Důležité pokyny k instalaci/montáži**

Instalaci/montáž musí při dodržení pokynů uvedených v tomto návodu a platných předpisů provést odborný pracovník s příslušným oprávněním pro tyto práce.

**[da] Vigtige anvisninger til installationen/monteringen**

Installationen/monteringen skal foretages af en godkendt installatør under overholdelse af denne vejledning og de gældende forskrifter.

**[el] Σημαντικές υποδείξεις για την εγκατάσταση/συναρμολόγηση**

Η εγκατάσταση/τοποθέτηση πρέπει να ανατίθεται σε εκπαιδευμένο για τις συγκεκριμένες εργασίες τεχνικό προσωπικό με τήρηση αυτών των οδηγιών καθώς και των σχετικών προδιαγραφών.

**[es] Indicaciones importantes para instalación/montaje**

La instalación/el montaje debe realizarla personal especializado que esté autorizado para realizar estos trabajos y que tenga en cuenta estas instrucciones y la normativa vigente.

**[et] Olulised juhised paigaldamiseks/montaažiks**

Paigaldamist/montaaži tohib läbi viia vaid selleks volitusi omav spetsialist, arvestades kehtivaid nõudeid.

**[nl-BE] Belangrijke aanwijzingen betreffende de installatie/montage**

De installatie/montage moet worden uitgevoerd door een voor de werkzaamheden geautoriseerde installateur rekening houdend met deze handleiding en de geldende voorschriften.

**[fi] Tärkeitä asennus- ja kokoonpano-ohjeita**

Näihin töihin hyväksytyn ammattiasentajan pitää suorittaa asennus- ja kokoonpanotyöt voimassa olevien määräysten mukaisesti.

**[hu] Fontos tudnivalók az installáláshoz/szereléshez**

A telepítést/szerelést egy, a munkálatokra felhatalmazott szakembernek kell végeznie, jelen utasítás és az érvényes előírások figyelembevételével.

**[it] Avvertenze importanti per l'installazione/il montaggio**

L'installazione/il montaggio deve aver luogo ad opera di una ditta specializzata ed autorizzata in osservanza di queste istruzioni e delle direttive vigenti.

**[ka] მნიშვნელოვანი მითითებები ინსტალაციისთვის/მონტაჟისთვის**

ინსტალაცია/მონტაჟი უნდა განხორციელდეს საბუნებრივად დასაშვებებისთვის დაშვებული კვალიფიციური პერსონალის მიერ, მოქმედი განაწესის დაცვით.

**[lt] Svarbios instaliavimo ir (arba) montavimo nuorodos**

Instaliavimo / montavimo darbus, laikydamiesi šios instrukcijos reikalavimų ir galiojančių taisyklių, privalo atlikti šioms darbams įgalioti specialistai.

**[lv] Svarīgi norādījumi par iekārtas uzstādīšanu / montāžu**

Uzstādīšanu/montāžu jāveic atbilstošajiem darbiem sertificētam speciālistam, ievērojot šo instrukciju un spēkā esošos noteikumus.

**[nl] Belangrijke aanwijzingen betreffende de installatie/montage**

De installatie/montage moet door een erkend installateur volgens de geldende voorschriften worden uitgevoerd.

**[no] Viktig informasjon om installasjon/montering**

Installasjonen/monteringen skal gjennomføres av autoriserte installatører, og installasjonsanvisningen samt gjeldende forskrifter skal følges.

**[pl] Ważne wskazówki dotyczące instalacji/montażu**

Instalację/montaż powinien wykonać specjalista uprawniony do tego typu prac z uwzględnieniem informacji podanych w niniejszej instrukcji oraz aktualnie obowiązujących przepisów.

**[pt] Indicações importantes relativas à instalação/montagem**

A instalação/montagem deve ser efectuada por um técnico autorizado para os trabalhos, respeitando este manual e as prescrições válidas.

**[ro] Indicații importante privind instalarea/montajul**

Instalarea/montajul trebuie realizate de către un specialist autorizat pentru lucrările respective, respectându-se prezentele instrucțiuni și prescripțiile valabile.

**[ru] Важные указания по подключению/монтажу**

Подключение/монтаж должны выполнять только специалисты, имеющие допуск к выполнению таких работ, при соблюдении требований этой инструкции и действующих норм и правил.

**[sk] Dôležité pokyny týkajúce sa inštalácie/montáže**

Inštaláciu/montáž musí vykonať odborný personál, ktorý má oprávnenie pre výkon týchto prác, pričom musí dodržiavať pokyny uvedené v tomto návode a platné predpisy.

**[sl] Pomembni napotki za namestitvev/montažo**

Inštalacijo/montažo lahko izvede samo pooblaščen strokovnjak ob upoštevanju teh navodil in veljavnih predpisov.

**[sr] Važna uputstva za ugradnju i montažu**

Ovu instalaciju/montažu moraju da obave stručna lica koja su ovlašćena za obavljanje takvih radova u skladu sa ovim uputstvom i važećim propisima.

**[sv] Viktiga anvisningar för installation/montering**

Installationen/monteringen måste utföras av en behörig och tekniskt utbildad person enligt denna anvisning samt gällande föreskrifter.

**[tr] Kurulum/Montaj ile ilgili önemli uyarılar**

Kurulum/montaj, bu çalışmalarını yapmasına müsaade edilen uzman kişiler tarafından işbu kılavuz ve geçerli yönetmelikler dikkate alınarak yapılmalıdır.

**[uk] Важливі вказівки щодо установки/монтажу**

Встановлення/монтаж повинні виконувати фахівці, що допущені до виконання таких робіт, із дотриманням цієї інструкції та діючих приписів.

**[zh] 安装方面的重要提示**

安装和组装工作必须由经过许可的专业人员进行，同时必须遵守本说明书和现行法规的相关要求

**[ar] ملاحظات هامة للتركيب/التجميع**  
يجب أن يتم التركيب/التجميع من قبل متخصص مصرح له بالعمل، مع مراعاة اللوائح السارية.

**[fa] تذکرات مهم درباره نصب/مونتاژ**  
نصب/مونتاژ باید توسط فردی حرفه ای که مجاز به انجام این کار است، و همچنین با توجه کامل به مقررات مربوطه انجام شود.

**[az] Quraşdırılma**

Quraşdırılma işinin yerinə yetirilməsi səlahiyyətli bir mütəxəssis tərəfindən və müvafiq qaydalara uyğun olaraq aparılmalıdır.

Ersatzteilliste  
Spare parts list

Liste des pièces de rechange  
Lista parti di ricambio

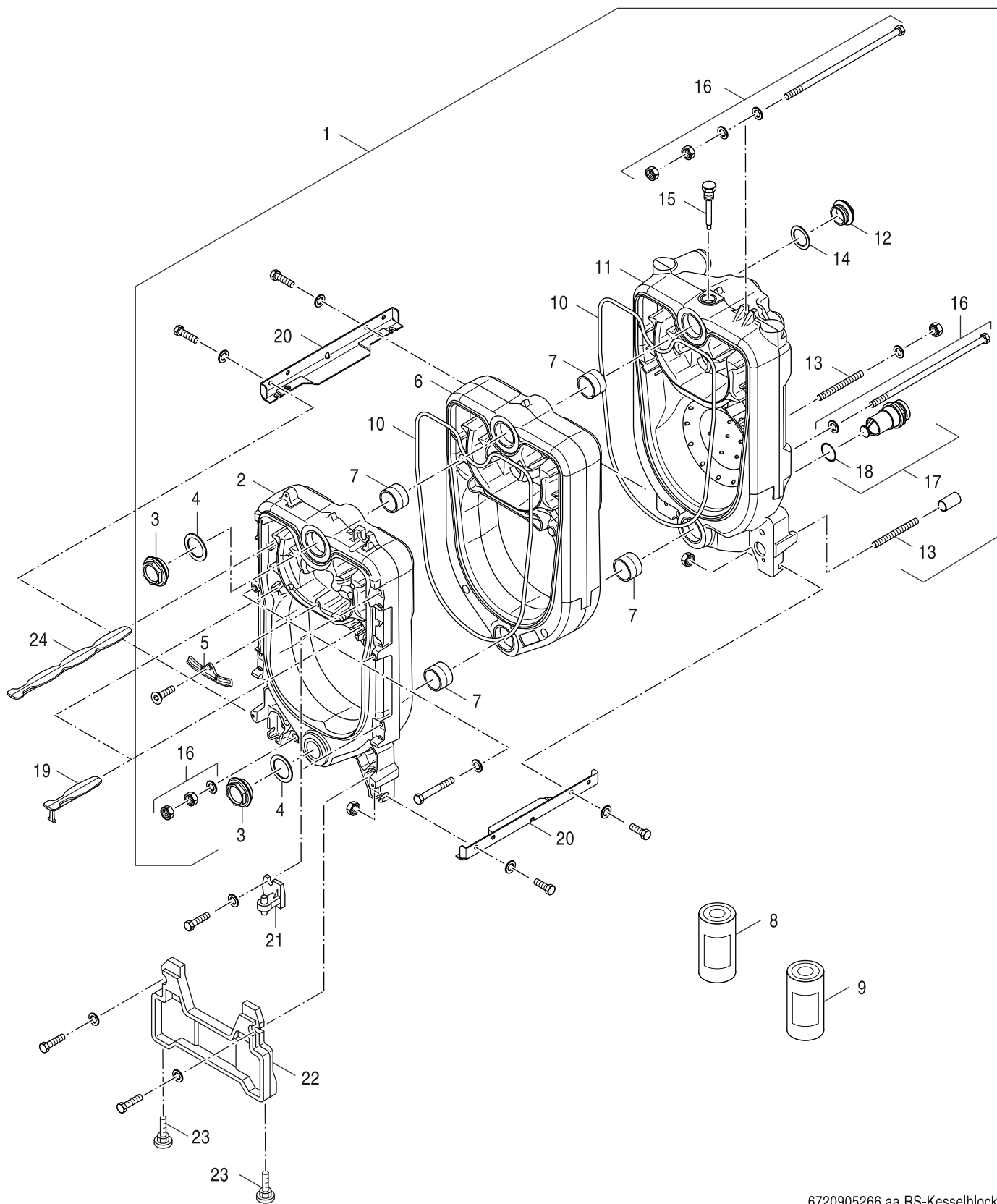

6720905266.aa.RS-Kesselblock

Kesselblock  
Boiler block  
Corps de chauffe  
Corpo caldaia

**GB125 18-60kW V5, MC110**

**1**

Pos	Bezeichnung Description Dénomination Descrizioni	Bestell-Nr. Ordering no. Numéro de commande N° d'ordine							Bemerkungen Remarks Remarques Osservazioni
			GB125-18	GB125-22	GB125-30	GB125-36	GB125-49	GB125-60	
1	Kesselblock 6Gld vorm everp	7 736 603 338							
1	Kesselbl GB125-3 Gld everp V3	7 736 616 420		■					
1	Kesselblock GB125-4 Gld everp V2	7 747 030 525			■				
1	Kesselblock GB125-2 Gld everp	8 718 588 590	■	■					
1	Kesselblock 5Gld everp	8 738 803 097				■			
2	Vorderglied 17-34 everp	8 718 585 129	■	■	■	■	■		
3	Blindstopfen G 1 1/4" re everp	8 718 571 258 0	■	■	■	■	■		
4	Dichtung D41,7x55x1,5 AFM 34 everp	8 738 807 916	■	■	■	■	■		
6	Mittelglied 17-34 everp	8 718 585 130	■	■	■	■	■		
7	Kesselnippel 48/38 Gr.0a everp	7 747 024 961	■	■	■	■	■		
8	Dichtmasse Leinölgraphit 450g Dose everp	8 718 571 927	■	■	■	■	■		
9	Haftgrund Teroson 1624-24 everp	8 718 576 019 0	■	■	■	■	■		
10	Dichtschnur D15x4300 Pack A serie/everp	8 718 584 415	■	■	■	■	■		
11	Hinterglied 17-34kW	8 718 584 710	■	■	■	■	■		
12	Stopfen G 1 everp	8 718 584 633	■	■	■	■	■		
13	Gewindestange M10x205 everp	7 747 007 599	■	■	■	■	■		
14	Dichtung D33x44x2 grafitiert everp	8 718 584 676	■	■	■	■	■		
15	Kessel-/STB-FühlerG1/4 45lg everp	6 302 487 7					■		
15	Fühler Kessel G1/4 75lg everp	6 302 964 1	■	■	■	■			
16	Ankerstange Satz M8x310 mit Kopf everp	5 127 574			■				
16	Ankerstange Satz M8x440 mit Kopf everp	5 127 578				■			
16	Ankerstange Satz M8x555 mit Kopf everp	5 127 580					■		
16	Ankerstangensatz M8x690 kpl everp	7 736 603 339						■	
16	Ankerstange Satz M8x190 mit Kopf everp	8 718 588 591	■	■					
17	Einspeisestück G 1 1/4 18-22KW everp	8 718 585 761	■	■					
17	Einspeisestück G 1 1/4 30-35kW everp	8 718 585 765			■	■			
17	Einspeisestück 5Gld everp	8 738 803 103					■	■	
18	O-Ring 44x3 Set (5x) everp	8 718 575 527 0	■	■	■	■	■		
19	Heizgaslenkplatte unten GB125 6Gld everp	7 736 603 340						■	
19	Heizgaslenkplatte 21kW/3GL m.Hebel everp	8 718 570 839 0			■				
19	Heizgaslenkplatte 28/4Gld everp	8 718 570 841 0				■			
19	Heizgaslenkplatte 40/5 Gld everp	8 718 570 842 0					■		
19	Heizgaslenkplatte 2 Gld mit Hebel everp	8 718 588 592	■	■					
20	Winkelprofilschiene GB125 6Gld everp	7 736 603 342						■	
20	Winkel Profilschiene 3Gld everp	7 747 000 018	■	■					
20	Winkelprofilschiene everp	7 747 000 019			■				
20	Winkelprofilschiene everp	7 747 000 020				■	■		
21	Scharnierwinkel everp	8 718 570 845 0	■	■	■	■	■		
22	Kesselfuß everp	8 718 584 682	■	■	■	■			
23	Gerätefuß M10x51 everp (4x)	6 302 865 7	■	■	■	■	■		
24	Heizgaslenkplatte oben GB125 6Gld everp	7 736 603 341						■	
24	Heizgaslenkplatte RLU everp	8 718 573 738 0			■				
24	Heizgaslenkplatte 5Gld RLU everp	8 718 584 681					■		
24	Heizgaslenkplatte 2 Gld. everp	8 718 588 593	■	■					

**GB125 18-60kW V5, MC110**

Kesselblock  
Boiler block  
Corps de chauffe  
Corpo caldaia

**1**



Ersatzteilliste  
Spare parts list

Liste des pièces de rechange  
Lista parti di ricambio

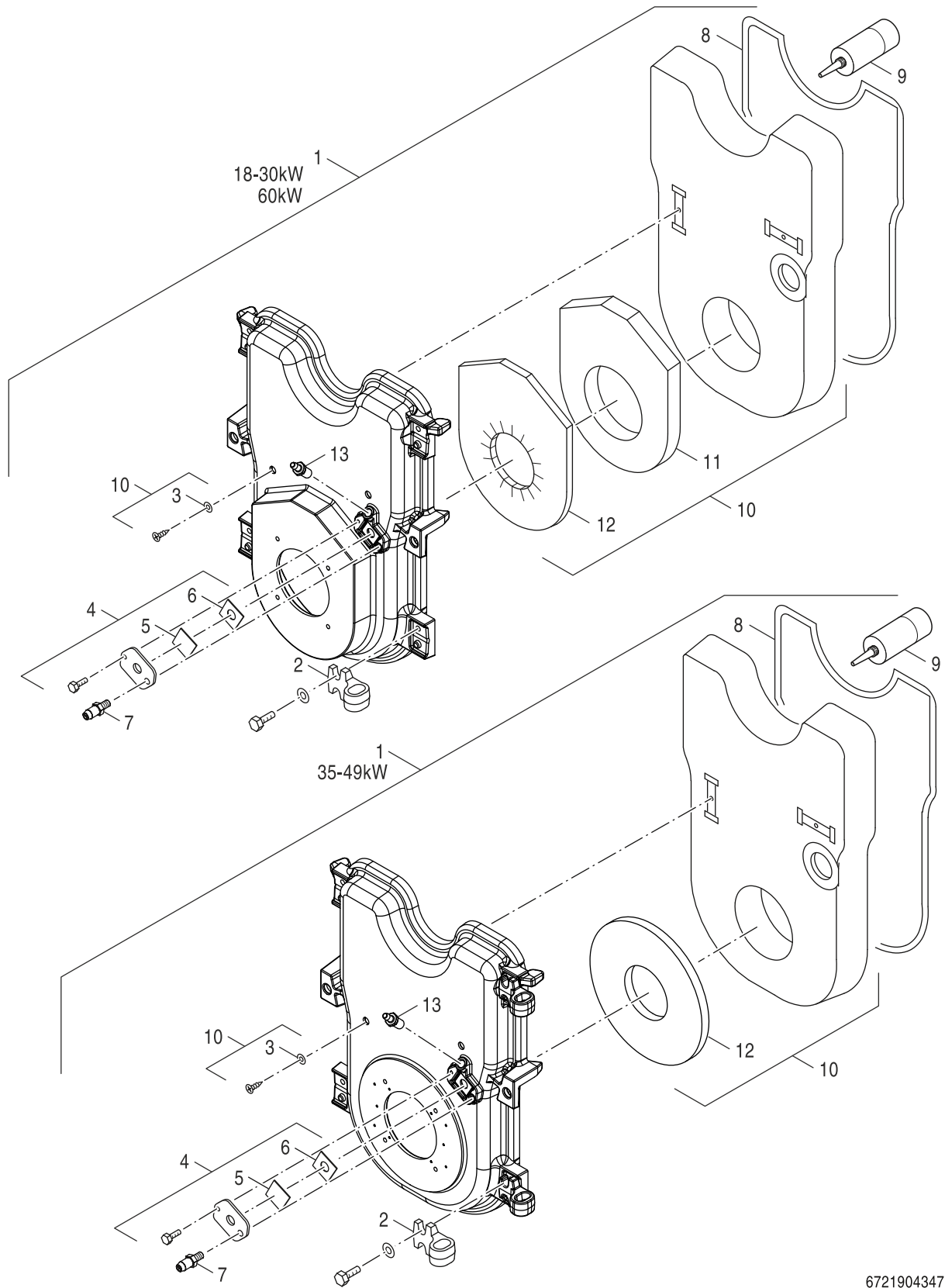

6721904347.aa.RO

**2**

Brennertür  
Door  
Porte  
Porta

**GB125 18-60kW V5, MC110**

Pos	Bezeichnung Description Dénomination Descrizioni	Bestell-Nr. Ordering no. Numéro de commande N° d'ordine							Bemerkungen Remarks Remarques Osservazioni
			GB125-18	GB125-22	GB125-30	GB125-36	GB125-49	GB125-60	
1	Brennertür GB 60 DE everp	7 736 603 337						■	
1	Brennertür GB 18-30 BE everp	8 738 806 305	■	■					
1	Brennertür GB 35-49 BE everp	8 738 806 306				■	■		
2	Scharnier lackiert everp	8 718 584 635	■	■	■	■	■		
3	Scheibe DIN9021 A6,4 A3K (1x) everp	8 718 585 241	■	■	■	■	■		
4	Schaulochverschluss V3 everp	6 302 363 4	■	■	■	■	■		
5	Glasscheibe 30x30x3,3mm everp	7 747 021 876	■	■	■	■	■		
6	Dichtung 30x30x3mm everp	8 718 584 679	■	■	■	■	■		
7	Druckmessdüse M6 SW10 everp	6 303 210 1	■	■	■	■	■		
8	Dichtschnur 14x1650 GP everp	6 302 096 5	■	■	■	■	■		
9	Dichtmasse braun 310ml everp	8 718 576 633 0	■	■	■	■	■		
10	Wärmeschutz Brennertür GB125/60 everp	7 736 603 333						■	
10	Wärmeschutz Br-Tür GB125 18-30 BE everp	8 738 806 307	■	■					
10	Wärmeschutz Br-Tür GB125 35-49 BE everp	8 738 806 308				■	■		
11	Wärmeschutz Br-Türvorbau G/GB125 everp	8 738 806 310	■	■				■	
12	Isoliering Br-Tür GB125 35-49 BE everp	8 738 806 311				■	■		
12	Isoliering Br-Tür GB125 everp	8 738 806 312	■	■				■	
13	Einschraubstutzen D6 G1/4" SW17 everp	7 736 603 344	■	■	■			■	

**GB125 18-60kW V5, MC110**

Brennertür  
Door  
Porte  
Porta

**2**



Ersatzteilliste  
Spare parts list

Liste des pièces de rechange  
Lista parti di ricambio

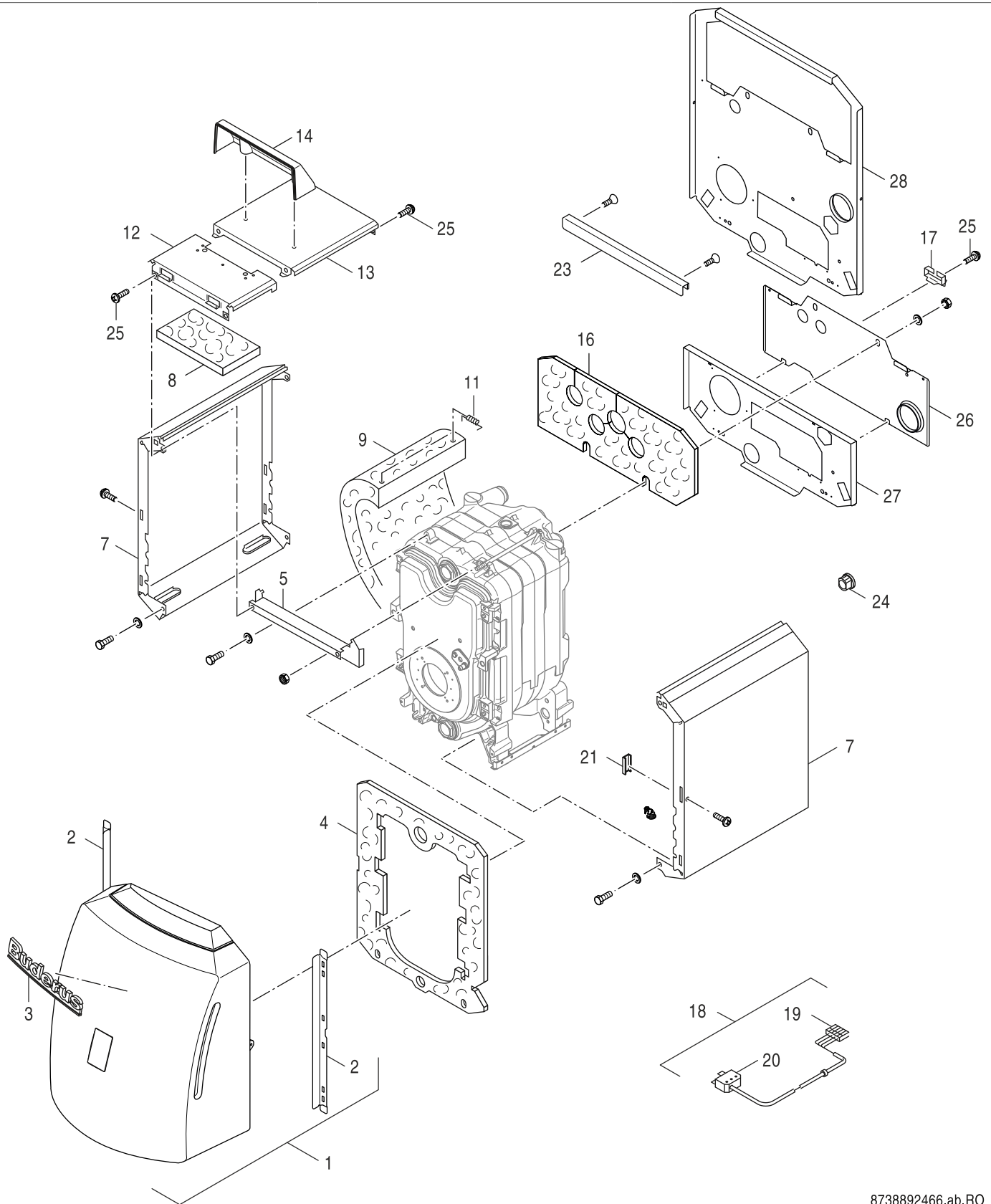

8738892466.ab.RO

**3** Verkleidung GB125 V3  
Casing GB125 V3  
Habillage GB125 V3  
Rivestimento GB125 V3

**GB125 18-60kW V5, MC110**

Pos	Bezeichnung Description Dénomination Descrizioni	Bestell-Nr. Ordering no. Numéro de commande N° d'ordine							Bemerkungen Remarks Remarques Osservazioni
			GB125-18	GB125-22	GB125-30	GB125-36	GB125-49	GB125-60	
1	Brennerhaube GB125 everp	8 718 573 812 0	■	■	■	■	■		
2	Winkel seitlich everp	8 718 584 013	■	■	■	■	■		
3	Logo Buderus 186mm everp	8 718 586 514	■	■	■	■	■		
4	Wärmeschutz vorn everp	6 302 526 5	■	■	■	■	■		
5	Traverse 1,25x108x537	6 302 920 9	■	■	■				
5	Traverse 5Gld everp	8 738 803 102				■	■		
7	Seitenwand G125 3Gld kpl everp	6 302 994 5	■	■					
7	Seitenwand G125/G134 4Gld kpl everp	6 302 994 6			■				
7	Seitenwand G125 5Gld kpl everp	6 302 994 7				■			
7	Seitenwand 6 Gld blau everp	7 736 603 345					■		
7	Seitenwand 5Gld Ersatz	8 738 803 099					■		
8	Wärmeschutz 18-35KW oben everp	8 718 583 550	■	■	■	■	■		
9	Wärmeschutz Kesselblock GB125-6Gld everp	7 736 603 335					■		
9	Wärmeschutz Kesselblock 3Gld everp	8 718 585 086			■				
9	Wärmeschutz Kesselblock 4Gld everp	8 718 585 087				■			
9	Isolierung Kesselblock GB125 -2Gld everp	8 718 588 596	■	■					
9	Wärmeschutz Kesselblock 5Gld everp	8 738 803 105					■		
11	Haltefeder (10x) everp	7 747 016 084	■	■	■	■	■		
12	Haube vorn G125 kompl	6 302 994 8	■	■	■	■			
12	Haube vorne 5Gld everp	8 738 803 100					■	■	
13	Haube hi G125 3Gld kpl everp	6 302 994 9	■	■					
13	Haube hi G125 4Gld everp	6 302 995 0			■				
13	Haube hi G125 5Gld everp	6 302 995 1				■			
13	Haube hinten 6 Gld blau everp	7 736 603 346					■		
13	Haube hinten 5Gld everp	8 738 803 101					■		
14	Anschlusshaube blau everp	6 302 626 1			■				
16	Wärmeschutz Rückwand everp	8 718 585 083	■	■	■	■	■		
17	Kabelhalter (5x) everp	8 718 584 331	■	■	■	■	■		
18	Brennerleitung 2350 1-Stufe everp	7 747 007 984	■	■	■	■			
19	Anschlussklemme 7-polig BR I grün everp	7 747 023 989	■	■	■	■			
20	Steckerteil ST18/7 versilbert everp	6 790 316 4	■	■	■	■			
21	Kantenschutz Set 65+80+160lg everp	6 302 089 6	■	■	■	■	■		
23	Winkel Rückwand V3 everp	8 718 588 405	■	■	■				
24	Kabeldurchführung everp	8 718 583 548	■	■	■	■	■		
25	Flachkopfschraube ST3,9x9,5 A3T (10x)	7 747 026 999	■	■	■	■	■		
26	Rückwand oben V2 everp	8 718 588 594	■	■	■				
27	Rückwand unten V4 everp	8 718 588 595	■	■	■				
28	Rückwand 5Gld everp	8 738 803 104					■	■	

**GB125 18-60kW V5, MC110**

Verkleidung GB125 V3  
 Casing GB125 V3  
 Habillage GB125 V3  
 Rivestimento GB125 V3

**3**

Ersatzteilliste  
Spare parts list

Liste des pièces de rechange  
Lista parti di ricambio

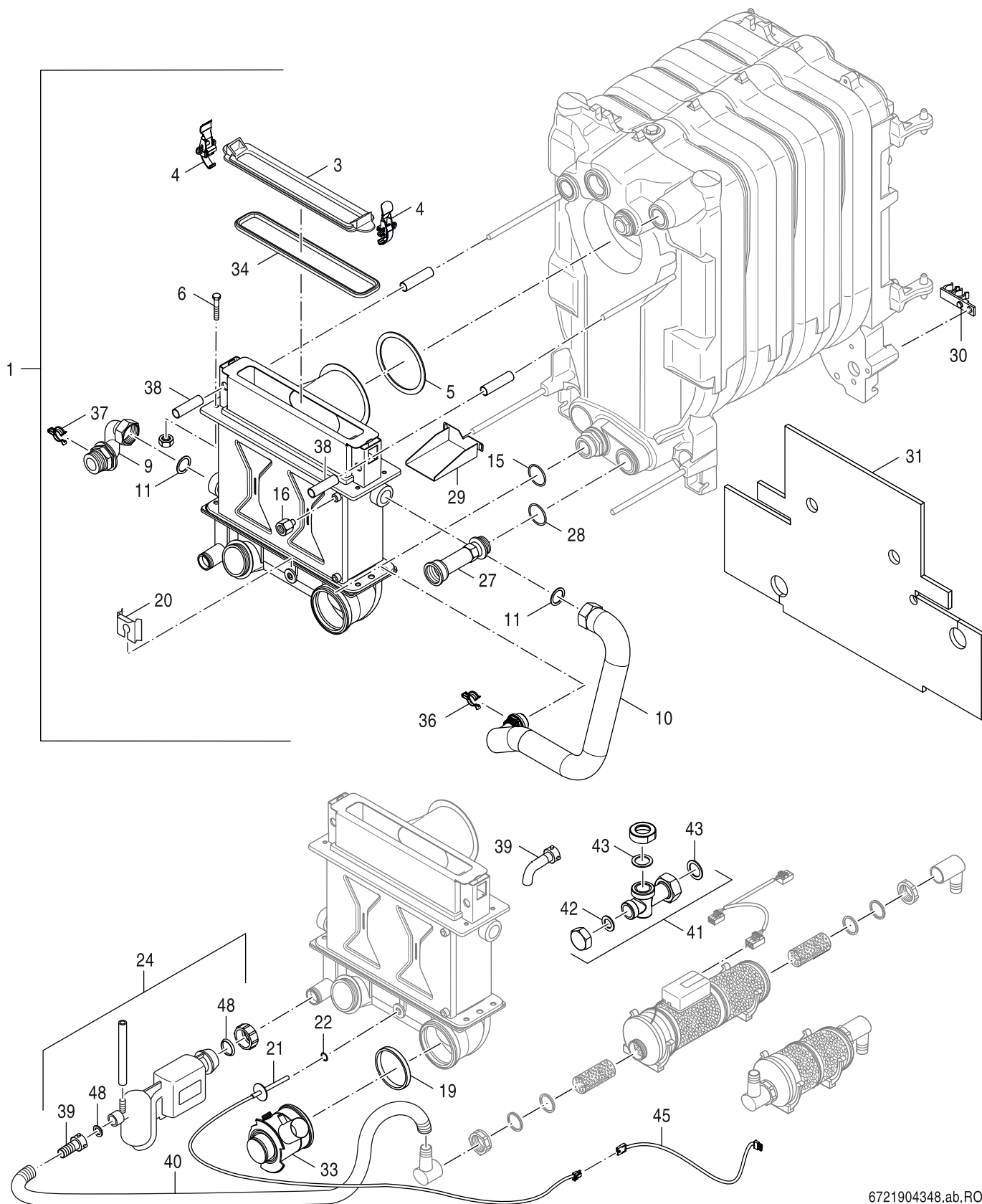

6721904348.ab.RO

Wärmetauscher  
Heat exchanger  
Échangeur thermique  
Scambiatore di calore

**GB125 18-60kW V5, MC110**

**4**

Pos	Bezeichnung Description Dénomination Descrizioni	Bestell-Nr. Ordering no. Numéro de commande N° d'ordine							Bemerkungen Remarks Remarques Osservazioni
			GB125-18	GB125-22	GB125-30	GB125-36	GB125-49	GB125-60	
1	WT-System 30-60 V2 everp	8 718 585 125			■	■	■		
1	WT-System 18-22 V2 everp	8 718 585 126	■	■					
3	Deckel Abgasv 18-22 Al kpl V3 everp	8 738 806 338	■	■					mit eingeklebter Dichtung
3	Deckel Abgasv 30-60 Al kpl V2 everp	8 738 806 339			■	■	■		mit eingeklebter Dichtung
4	Schnellverschluss	7 098 848	■	■	■	■	■		
5	Dichtung Fasermat Hgl-Abgasvert everp	8 718 581 466	■	■	■	■	■		
6	Schrauben-Set everp	8 718 585 089	■	■	■	■	■		
9	Rücklauf Rohr HK/WT G1 V3 everp	8 718 588 597	■	■					
9	Rücklauf-Rohr HK/WT G1 1/4 V3 everp	8 718 588 598			■	■	■		
10	Rücklauf-Rohr RK/WT G1 everp V2	7 747 030 541	■	■					
10	Rücklauf-Rohr RK/WT G 11/4 V2 everp	8 718 571 053 0			■	■	■		
11	Dichtung D21X30X3, DVGW-zugel.(5x) everp	8 718 584 714	■	■	■	■	■		
15	O-Ring 21,89x2,62 70EPDM everp (5Stk)	8 718 570 357 0	■	■					
15	O-Ring 28x3 70EPDM/281 everp 5Stk	8 718 571 057 0			■	■	■		
16	Entlüfter 1/8 BSP	8 716 140 238 0	■	■	■	■	■		
19	Lippendichtung DN80 PerOxyd (5x) everp	7 747 021 733	■	■	■	■	■		
20	Fühlerhalterung (2x) everp	8 718 585 548	■	■	■	■	■		
21	Abgasfühler D29/d6 60mm everp	7 747 002 902	■	■	■	■	■		
22	O-Ring 6x2 ISO 3601 FKM (3x) everp	7 747 007 462	■	■	■	■	■		
24	Siphon-Set V4 everp	8 738 806 366	■	■	■	■	■		
27	Verlängerung G1x120 V2 everp	8 718 585 117	■	■	■	■	■		
28	O-Ring 35x3 Set (5x) everp	8 718 575 526 0	■	■	■	■	■		
29	Halter Siphon GB125 V4 everp	8 718 588 600	■	■	■	■	■		
30	Leitungshalter everp	8 718 585 071	■	■	■	■	■		
31	Wärmeschutz WT 18-22 kW everp	8 718 585 084	■	■					
31	Wärmeschutz WT 30-35 kW everp	8 718 585 085			■	■	■		
33	Kesselanschlussstück RC250C everp	8 718 592 663	■	■	■	■	■		60kW-Nur Innenrohr nutzen
34	Dichtung Abgasv 30-35 Al V2 everp	8 718 579 535			■	■	■		
34	Dichtung Abgasvert 18-22KW AL everp	8 718 585 764	■	■					
36	Federclip d=32,6/22 everp (5Stk)	7 747 030 542	■	■					
36	Federclip d=38,2/28 everp 5Stk	8 718 571 056 0			■	■	■		
37	Federstecker D26 everp	7 747 030 559	■	■	■	■	■		
38	Isolierung Gewindestange 36,2 everp	7 747 015 461			■	■	■		
38	Distanzhülse 17,2x2,1x63,5 everp	8 718 590 261	■	■					
39	Verschraubung 2/3 R3/4 everp	7 747 021 911	■	■	■	■	■		
39	Schlauchtülle G3/4x20 gewinkelt everp	8 738 803 123	■	■	■	■	■		alternativ
40	Schlauch-Set DN20 (3m) verp	7 747 007 644	■	■	■	■	■		Zubehör
41	T-Stück kpl everp	5 584 368	■	■	■	■			
41	T-Stück 60 kW everp	8 738 805 365					■		
42	Dichtung D18x30x2 EPDM everp	8 718 585 262	■	■	■	■	■		
43	Dichtung D27x38x2 DVGW-zugelassen everp	8 718 584 801	■	■	■	■	■		
45	Leitung Verlängerung Abgasfühler 330 eve	8 732 919 259					■		
48	Dichtungs-Set Siphon everp	7 747 016 504	■	■	■	■	■		

**GB125 18-60kW V5, MC110**

Wärmetauscher  
Heat exchanger  
Échangeur thermique  
Scambiatore di calore

**4**

Ersatzteilliste  
Spare parts list

Liste des pièces de rechange  
Lista parti di ricambio

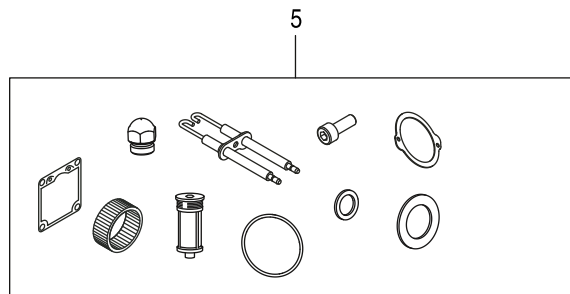
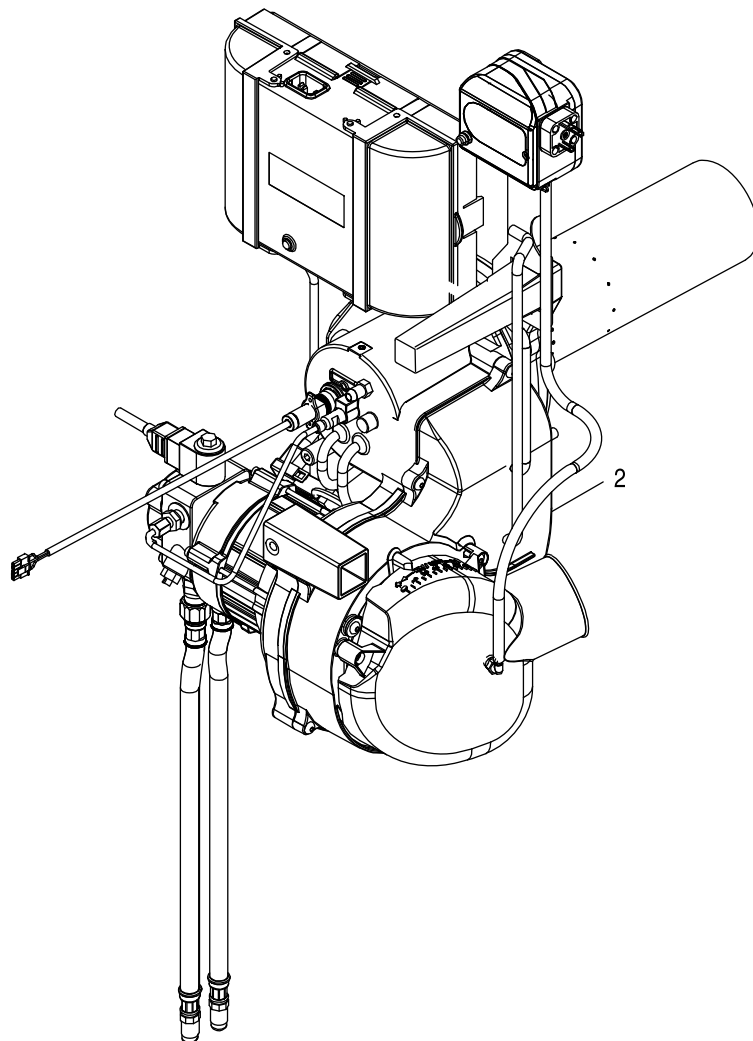

6721904349.aa.RO

**5**  
Brennervarianten  
Burner versions  
Variantes de brûleur  
Varianti bruciatore

**GB125 18-60kW V5, MC110**

Pos	Bezeichnung Description Dénomination Descrizioni	Bestell-Nr. Ordering no. Numéro de commande N° d'ordine																			Bemerkungen Remarks Remarques Osservazioni
			GB125-18	GB125-22	GB125-30	GB125-35	GB125-49	GB125-60													
2	Ölbrenner BE 2.3-60 K RLA everp	7 736 603 347						■													
2	Ölbrenner BE 1.3-18 kpl V3 everp	8 738 806 297	■																		
2	Ölbrenner BE 1.3-22 kpl V3 everp	8 738 806 298		■																	
2	Ölbrenner BE 2.3-30 kpl V3 everp	8 738 806 299			■																
2	Ölbrenner BE 2.3-35 kpl V3 everp	8 738 806 300				■															
2	Ölbrenner BE 2.3-49 kpl V3 everp	8 738 806 301					■														
5	Service-Set BE 18kW everp	7 736 604 320	■																		
5	Service-Set BE 22kW everp	7 736 604 321		■																	
5	Service-Set BE 30kW everp	7 736 604 322			■																
5	Service-Set BE 35kW everp	7 736 604 323				■															
5	Service-Set BE 49kW everp	7 736 604 324					■														
5	Service-Set BE 60kW everp	7 736 604 325						■													

**GB125 18-60kW V5, MC110**

Brennervarianten  
Burner versions  
Variantes de brûleur  
Varianti bruciatore

**5**

Ersatzteilliste  
Spare parts list

Liste des pièces de rechange  
Lista parti di ricambio

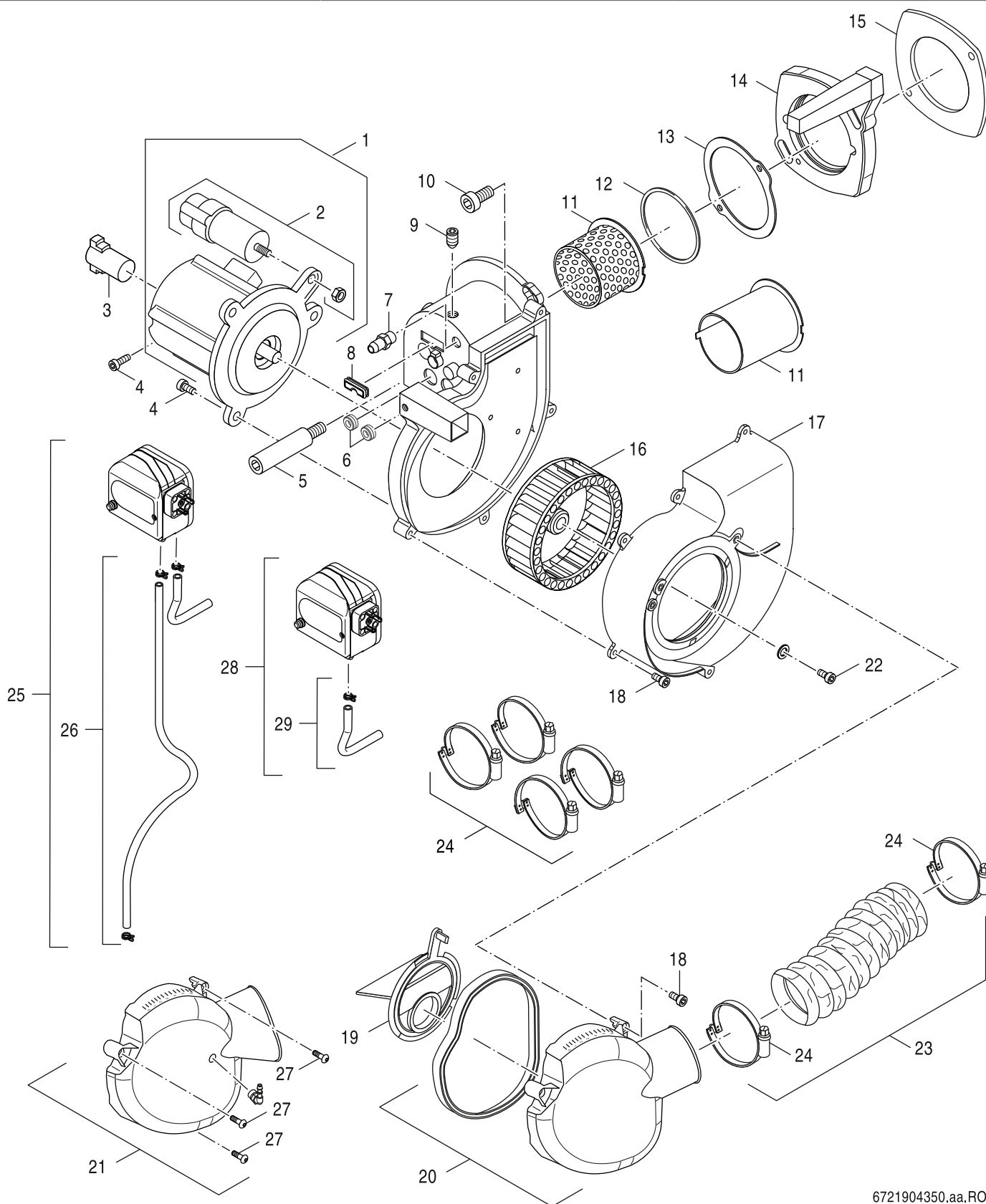

6721904350.aa.RO

Brennergehäuse  
Burner housing  
Lgement de brûleur  
Alloggiamento del bruciatore

**GB125 18-60kW V5, MC110**

**6**



Pos	Bezeichnung Description Dénomination Descrizioni	Bestell-Nr. Ordering no. Numéro de commande N° d'ordine							Bemerkungen Remarks Remarques Osservazioni
			GB125-18	GB125-22	GB125-30	GB125-36	GB125-49	GB125-60	
1	Motor HG 150W everp	6 300 376 8	■	■					
1	Motor HG 170W everp	6 300 686 5			■	■	■		
2	Kondensator 4MF400V für Motor AEG verp	5 885 624	■	■					
2	Kondensator 5MF400V für Motor FHP everp	8 718 584 677			■	■	■		
3	Kupplung weiß (2x) 2-flächig	8 718 572 841 0	■	■	■	■	■		
4	Zylinderschraube DIN912 M5x12 (10x)	6 302 287 1	■	■	■	■	■		
5	Gewindebolzen M8x25/D13/K105 everp	8 718 571 345 0	■	■	■	■	■		
6	Kabeldurchführung D14/4 everp	8 718 584 650	■	■	■	■	■		
7	Druckmessdüse R 1/8" Ms everp	8 718 584 643	■	■	■	■	■		
8	Kabeldurchführung 29x11x4 everp	8 718 584 656	■	■	■	■	■		
9	Gewindestift DIN916 M6x8 (3x)	7 747 029 978	■	■	■	■	■		
10	Zyl.-Schr. DIN7984 M8x25 8.8 A3K (2x)	8 718 584 683	■	■	■	■	■		
11	Verteilzylinder HG-A everp V1	6 300 687 6			■				
11	Verteilzylinder HG-A everp V2	6 300 975 9				■	■		
11	Verteilzylinder HG-A Ringspalt4,9 everp	6 303 253 2	■	■					
12	O-Ring 92x3 Viton everp	6 300 299 8	■	■	■	■	■		
13	Dichtung D128x2 everp	6 302 516 0	■	■	■	■			
14	Brennerflansch HG-A everp	7 736 603 336	■	■	■	■	■		
15	Dichtung 143x143x6 everp V3	7 747 000 719	■	■	■	■	■		
16	Gebläserad D133x38,4 V2 everp	6 300 377 9	■	■					
16	Gebläserad D133x59,8 V2 everp	6 300 378 0			■	■	■		
17	Gehäusedeckel HG-A Gr1 everp	6 300 688 5	■	■					
17	Gehäusedeckel HG-A Gr2 everp	6 300 688 6			■	■	■		
18	Linsenschraube ISO7380 M5x20 (5x)	7 747 029 974	■	■	■	■	■		
19	Ansaugluftführung HG-A Gr1 everp	6 300 686 9	■	■					
19	Ansaugluftführung HG-A Gr2 everp	6 300 687 3			■	■	■		
20	Ansaugschalldämpfer HG-A RLU kpl everp	6 302 880 1	■	■	■	■			
21	Ansaugschalldaempfer HG-A V3 kpl everp	7 736 603 334					■		
22	Linsenschraube ISO7380 M5x8 (5x)	7 747 029 977	■	■	■	■	■		
23	Luftschlauch WaBiSanto DN63 L1600 everp	8 738 803 852	■	■	■	■			
24	Spiral-Schlauschellen 60/80 everp	8 718 577 764	■	■	■	■			
25	Druckwächter DL 10KH-5 Z 290/70 kpl ev	8 738 807 390				■	■		
26	Schlauchset Druckwächter everp	7 736 603 349				■	■		
27	Linsenschraube ISO7380 M5x16 (5x)	8 718 571 346 0				■	■		
28	Druckwächter DL 10KH-5 Z 100/70 kpl ev	8 738 807 388	■						
28	Druckwächter DL 10KH-5 Z 140/70 kpl ev	8 738 807 389		■	■	■			
29	Schlauchset Druckwächter GB125 everp	8 738 806 304	■	■	■				

**GB125 18-60kW V5, MC110**

Brennergehäuse  
Burner housing  
Lgement de brûleur  
Alloggiamento del bruciatore

**6**

Ersatzteilliste  
Spare parts list

Liste des pièces de rechange  
Lista parti di ricambio

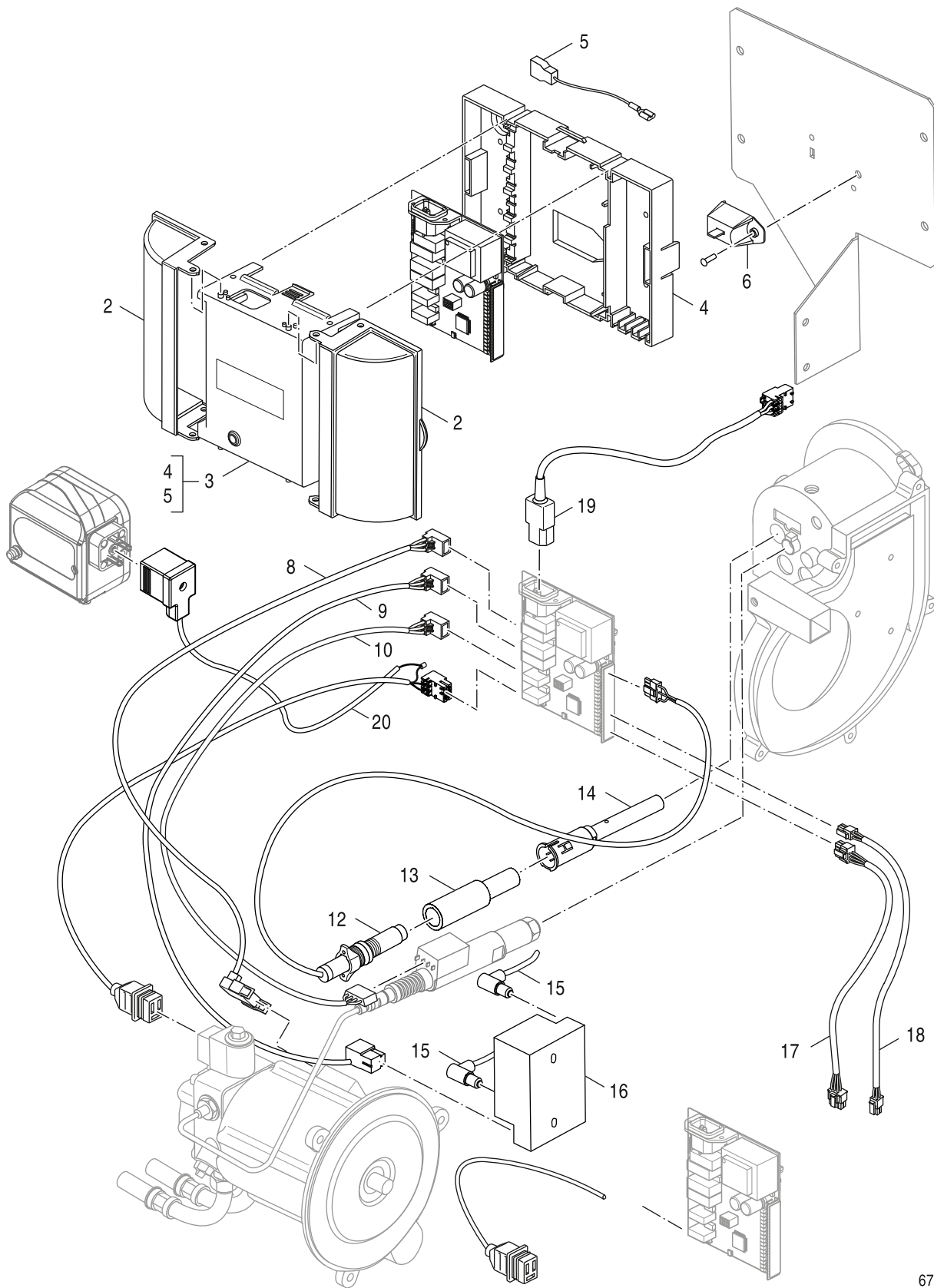

6721904351.aa.RO

**7** Brennersteuerung  
control unit  
Commande  
Unità di comando

**GB125 18-60kW V5, MC110**

Pos	Bezeichnung Description Dénomination Descrizioni	Bestell-Nr. Ordering no. Numéro de commande N° d'ordine	GB125-18	GB125-22	GB125-30	GB125-36	GB125-49	GB125-60												Bemerkungen Remarks Remarques Osservazioni
2	Gehäuse Klemmenabdeckung SAFe everp	6 302 392 5	■	■	■	■	■													
3	SAFe30 V7 DNA everp	8 732 936 996	■	■	■	■	■													
4	Gehäuse Unterteil SAFe everp	6 302 393 0	■	■	■	■	■													
5	Adapter H05V-K 0,75 0,8/2,0 gn/ge verp	6 303 350 7	■	■	■	■	■													
6	Modul BIM30 V10 GB125-60 everp	8 732 919 565						■												Nur für Service-Techniker
6	Modul BIM30*-LoI/01 V10 18-49 everp	8 738 806 346	■	■	■	■														Nur für Service-Techniker
8	Verbindungsleitung SAFe-Motor BE everp	6 303 014 8	■	■	■	■														
8	Verbindungsleitung Motor 380 everp	8 732 912 559						■												
9	Verbindungsleitung Zündung 410 everp	8 732 912 561						■												
9	Zündleitung SAFe 230V everp	8 738 802 738	■	■	■	■														
10	Verbindungsleitung Ölvorw SAFe BE everp	6 303 014 9	■	■	■	■														
10	Verbindungsleitung Ölvorwärmer 375 everp	8 732 912 562						■												
12	UV-Flammenfühler QRC SAFe BZ/BE_3everp	6 303 396 5	■	■	■	■	■													
13	Halterohrverlängerung BE_3 RLU V2	7 747 001 399	■	■	■	■	■													
14	Halterohr HG V4 everp	8 718 585 517	■	■	■	■	■													
15	Zündleitung BE/BE-A everp	6 300 689 0	■	■	■	■														
15	Zündleitung Reakt. 1550 Ohm 275mm everp	8 732 919 563						■												
16	Zündeinrichtung Danfoss EBI V4 everp	8 718 575 099 0	■	■	■	■	■													
17	Datenleitung SAFe MC10 BE everp	6 303 015 0	■	■	■	■	■													
18	Verbindungsleitung Kesselfühler SAFe BE	6 303 921 4	■	■	■	■														
18	Verbindungsleitg Kesselfüh SAFe 1900 everp	8 732 912 855						■												
19	Verbindungsleitung SAFe Netz 1250 everp	8 732 912 558	■	■	■	■	■													
20	Verbindungsleit MV 1 Druck 320/580 everp	8 732 912 560	■	■	■	■	■													

**GB125 18-60kW V5, MC110**

Brennersteuerung  
control unit  
Commande  
Unità di comando

**7**

Ersatzteilliste  
Spare parts list

Liste des pièces de rechange  
Lista parti di ricambio

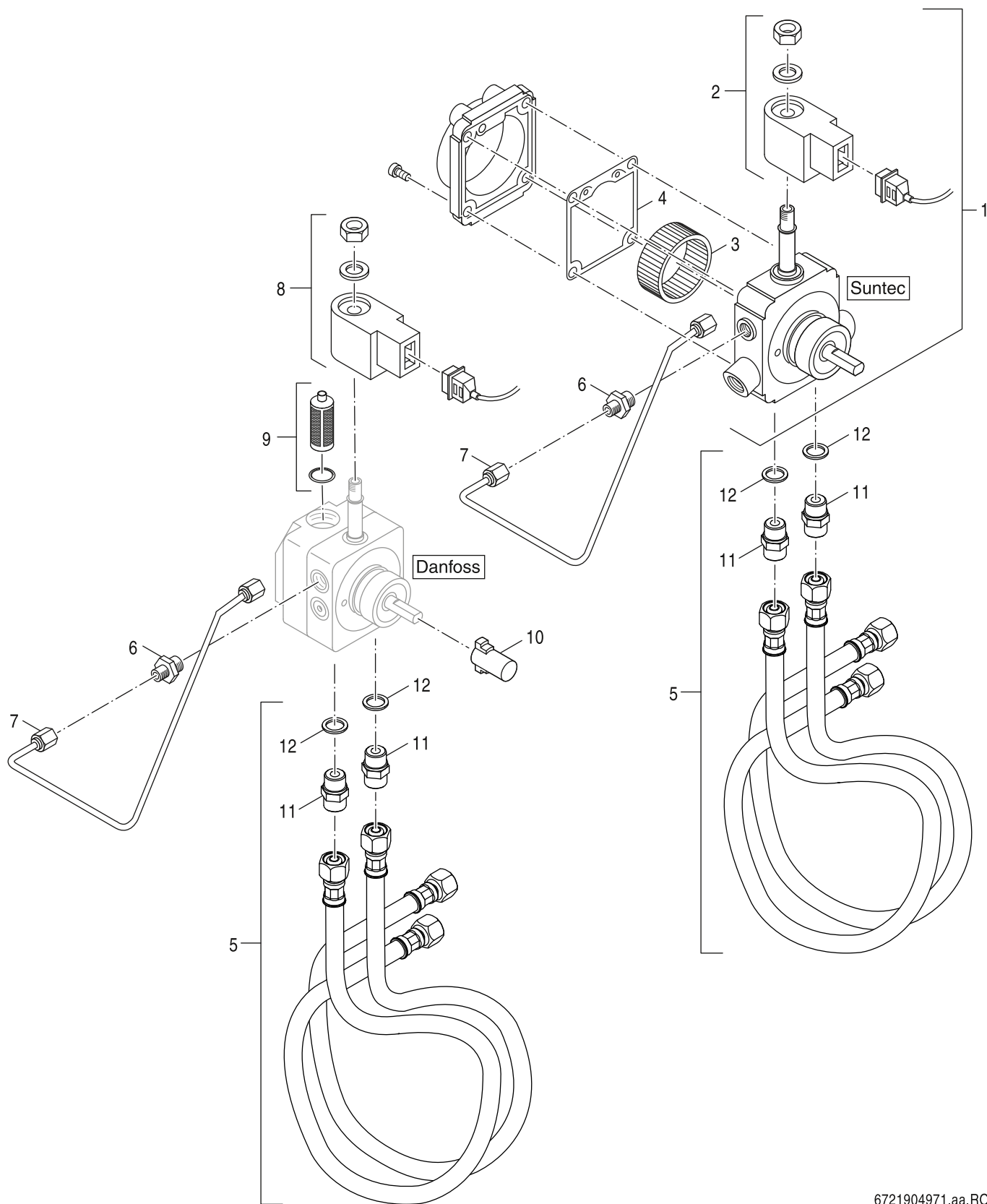

6721904971.aa.RO

**8B**  
Ölpumpe  
oil pump  
Pompe à fioul  
Pompa gasolio

**GB125 18-60kW V5, MC110**

Pos	Bezeichnung Description Dénomination Descrizioni	Bestell-Nr. Ordering no. Numéro de commande N° d'ordine	GB125-18	GB125-22	GB125-30	GB125-36	GB125-49	GB125-60												Bemerkungen Remarks Remarques Osservazioni
1	Ölpumpe Suntec ALEV35C everp	8 718 578 019	■	■																
1	Ölpumpe Suntec ALEV55C everp	8 718 578 021				■	■	■												
2	Magnetspule Suntec220-240V/50-60Hz everp	7 747 021 595	■	■	■	■	■	■												
3	Filter Ölpumpe A70 Rev.3 AS47 (2x)	8 718 572 496 0	■	■	■	■	■	■												
4	Dichtung Ölpumpe ALE35/55 (2x) everp	8 718 572 498 0	■	■	■	■	■	■												
5	Schlauchset BE/RE	6 301 424 1	■	■	■	■	■	■												
6	Einschraubverschr GE 4LLR 1/8"Zyl everp	8 718 592 457	■	■	■	■	■	■												
7	Örohr HG-A kpl everp	8 718 584 674	■	■	■	■	■	■												
8	Magnetspule BFP 21/31 L3 everp	8 718 572 501 0	■	■	■	■	■	■												
9	Filter Ölpumpe BFP 21/31 L3 (2x)	8 718 572 503 0	■	■	■	■	■	■												
10	Kupplung weiß (2x) 2-flächig	8 718 572 841 0	■	■	■	■	■	■												
11	Verschraubung G3/8" x G1/4" gerade everp	8 718 584 651	■	■	■	■	■	■												
12	Dichtring 13x18x1,5 (5x) everp	8 718 584 808	■	■	■	■	■	■												

**GB125 18-60kW V5, MC110**

Ölpumpe  
oil pump  
Pompe à fioul  
Pompa gasolio

**8B**

Ersatzteilliste  
Spare parts list

Liste des pièces de rechange  
Lista parti di ricambio

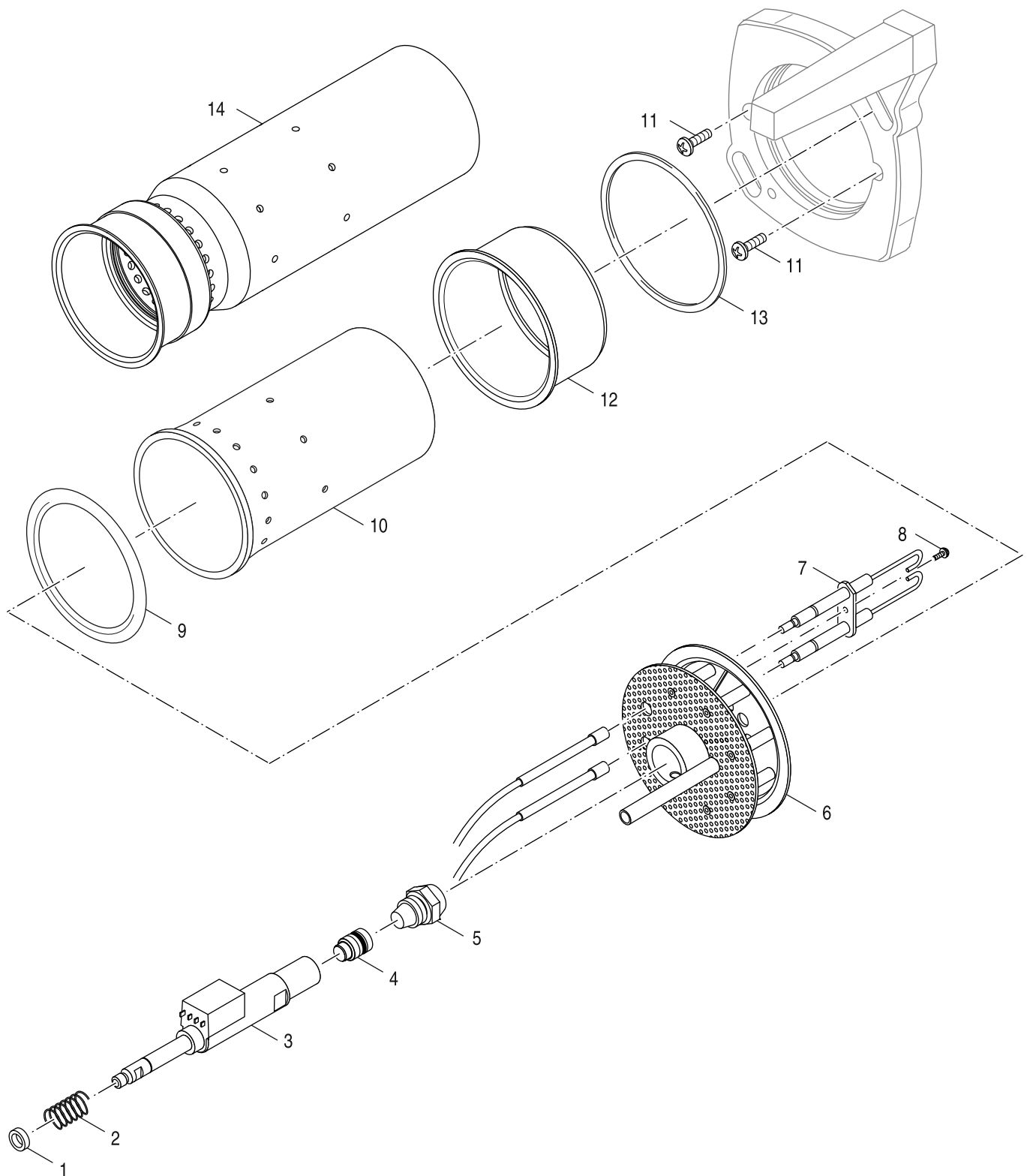

6721904352.aa.RO

**9A** Mischeinrichtung  
mixer Suntec  
Chambre de melange Suntec  
Dispositivo di miscelazione Suntec

**GB125 18-60kW V5, MC110**

Pos	Bezeichnung Description Dénomination Descrizioni	Bestell-Nr. Ordering no. Numéro de commande N° d'ordine							Bemerkungen Remarks Remarques Osservazioni
			GB125-18	GB125-22	GB125-30	GB125-36	GB125-49	GB125-60	
1	Scheibe D9,5/14x4 Ver02 everp	8 718 584 673	■	■	■	■	■		
2	Druckfeder DIN2098 1,8x12,5x36 everp	7 747 012 279	■	■	■	■	■		
3	Ölvorwärmer FPHE-LE 030N5129 PTC50 everp	8 718 578 602	■	■					
3	Ölvorwärmer FPHB5-LE PTC70 B10 everp	8 718 578 603			■	■	■		
4	Abschlussventil LE6 everp	6 302 512 6	■	■	■	■	■		
5	Öldüse 0,55gph 60Gr HR Danfoss everp	7 736 604 063			■				
5	Öldüse 1,00gph 60Gr H Danfoss everp	7 747 028 942					■		
5	Öldüse 0,45gph 80Gr HFD Danfoss everp	7 747 028 943		■					
5	Öldüse 0,85gph 60Gr H everp	7 747 028 962					■		
5	Öldüse 0,35gph 80Gr HR everp (1x)	7 747 028 974	■						
5	Öldüse 0,45gph 80Gr HFD Danfoss (12x)	7 747 028 988		■					
5	Öldüse 0,35gph 80Gr HR Danfoss (10x)	7 747 028 991	■						
5	Öldüse 0,65gph 80° everp	8 718 572 504 0				■			
5	Öldüse 0,55gph 60Gr HR Danfoss 10 Pack	8 738 807 238			■				
6	Mischsystem BE 12,0/25,0/5,0/25 everp	7 747 002 844	■						
6	Mischsystem BE 12,1/27,5/5,8/25 everp	7 747 002 845		■					
6	Mischsystem BE 12,1/27,5/6,9/25 VA everp	7 747 002 846			■				
6	Mischsystem BE 12,4/27,5/8,3/25 VA everp	7 747 002 847				■			
6	Mischsystem BBE/BE-A 2.1-43/45kW everp	8 718 585 041					■		
6	Mischsystem BE 55kW everp	8 718 585 042						■	
7	Zünderlektrode BE/BE-A Typ4 L34 everp	8 718 585 036	■	■	■	■			
7	Zünderlektrode BE Typ4 L50 V2 everp	8 718 585 045					■		
7	Zünderlektrode BE T4 L 58,5 V2 everp	8 718 585 046						■	
8	Zylinderschraube DIN912 M4x10 (5x)everp	7 747 029 972	■	■	■	■	■		
9	Dichtung D75,5 V2 everp	6 303 793 0						■	
9	Dichtung D81 V2 everp	8 718 585 504	■	■	■	■	■		
10	Brennerrohr D69/L214 SiC 18kW everp	6 302 260 4	■						
10	Brennerrohr D83/L214/3,0/2,5 SiC 25kW	6 302 260 7		■					
10	Brennerrohr D83/L224/5,9/4,8 SiC everp	6 303 072 7			■				
10	Brennerrohr D83/L224/7,0/5,7 SiC everp	6 303 072 8				■			
10	Brennerrohr D83/L224/5,7/5,4 SiC everp	6 303 072 9					■		
11	Linsenschraube ISO7380 M5x8 (5x)	7 747 029 977	■	■	■	■	■		
12	Stützrohr L50 everp	6 302 259 5	■	■	■	■	■		
13	O-Ring 92x3 Viton everp	6 300 299 8	■	■	■	■	■		
14	Brennerrohr D96/L257,5/5,5/4,9/4,9-8 eve	6 303 364 1						■	
	Mont-Mat Ölbrenner BE everp	8 718 585 037	■	■	■	■	■		

**GB125 18-60kW V5, MC110**

Mischeinrichtung  
mixer Suntec  
Chambre de melange Suntec  
Dispositivo di miscelazione Suntec

**9A**



Ersatzteilliste  
Spare parts list

Liste des pièces de rechange  
Lista parti di ricambio

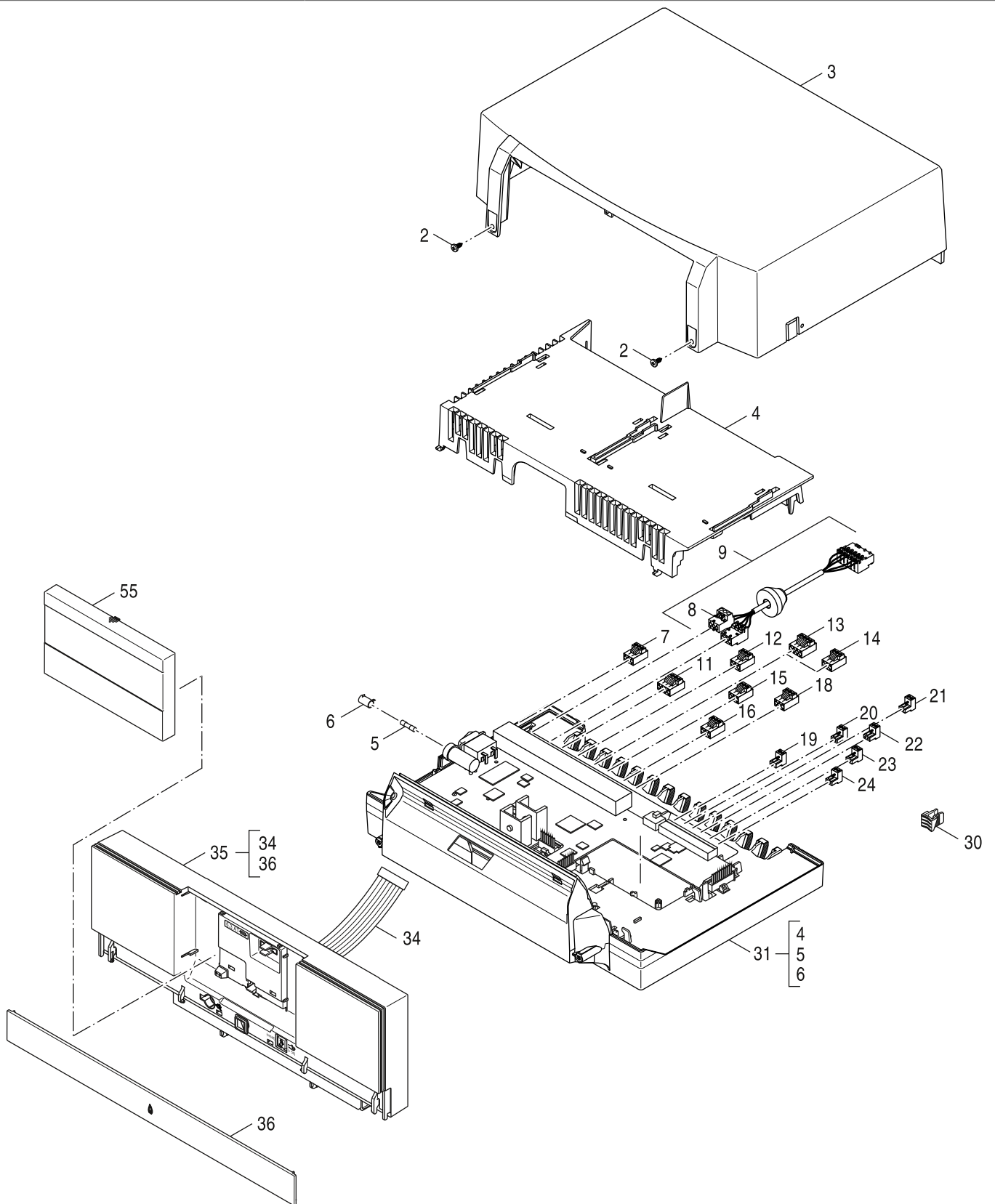

6721904597.aa.RO

**GB125 18-60kW V5, MC110**

**9B**

RMC110  
RMC110  
RMC110  
RMC110

Pos	Bezeichnung Description Dénomination Descrizioni	Bestell-Nr. Ordering no. Numéro de commande N° d'ordine							Bemerkungen Remarks Remarques Osservazioni
			GB125-18	GB125-22	GB125-30	GB125-36	GB125-49	GB125-60	
2	Schraube M 3,5 x 12 (6x)	7 736 700 684	■	■	■	■	■		
3	Gehäuseoberteil blau everp	8 718 583 355	■	■	■	■	■		
4	Modulträger weiß everp	8 718 586 090	■	■	■	■	■		
5	Sicherungseinsatz 5x20 6,3AT230V (10X)	8 718 578 518	■	■	■	■	■		
6	Sicherungshalter-Kappe everp	8 718 221 358 0	■	■	■	■	■		
7	Anschlussklemme 3-pol Netz weiß everp	7 747 023 981	■	■	■	■	■		
8	Anschlussklemme 3-pol. SF50 rosa everp	8 718 586 071	■	■	■	■	■		
9	Kabelbaum Power HV 1270 Ferrit everp	8 718 592 373	■	■	■	■	■		
11	Anschlussklemme 4-pol orange 17B18 everp	8 718 590 270	■	■	■	■	■		
12	Anschlussklemme 3-pol gelb everp	7 747 026 994	■	■	■	■	■		
13	Anschlussklemme 4-pol viol. SH I Mischer	7 747 023 966	■	■	■	■	■		
14	Anschlussklemme 3-pol.PS Pumpe grau ever	7 747 023 985	■	■	■	■	■		
15	Anschlussklemme 3-pol. PZ Pumpe violett	7 747 023 986	■	■	■	■	■		
16	Anschlussklemme 3-pol. PH grün everp	7 747 023 983	■	■	■	■	■		
18	Anschlussklemme 3-pol. rot everp	8 718 586 111	■	■	■	■	■		
19	Anschlussklemme 2-pol WA maigrün everp	7 747 023 154	■	■	■	■	■		
20	Anschlussklemme 2-pol R5 blau everp	7 747 027 014	■	■	■	■	■		
21	Anschlussklemme 2-pol grau FW	7 747 026 992	■	■	■	■	■		
22	Anschlussklemme 2-pol toro EV Klemme	7 747 026 991	■	■	■	■	■		
23	Anschlussklemme 2-pol. orang RC everp	7 747 023 151	■	■	■	■	■		
24	Anschlussklemme 2-pol. weiss everp	7 747 023 129	■	■	■	■	■		
30	Zugentlastung f. Regelgerät (10x) everp	8 718 583 348	■	■	■	■	■		
31	Leiterplatte MC110 S14 blau	7 736 606 570	■	■	■	■	■		
34	Leitung Set Bus BC110-IMC110 everp	8 732 909 190	■	■	■	■	■		
35	Bedientableau BC110 S04 everp	8 732 909 185	■	■	■	■	■		
36	Gehäuse Klappe BC110 everp	8 732 909 187	■	■	■	■	■		
55	Blindabdeckung RC3xx schwarz everp	8 732 909 226	■	■	■	■	■		
	Temperaturfühler RD 6,0 10k# 3000mm	7 735 502 295	■	■	■	■	■		
	Buderus Logamatic MC110 S14 blau verp	7 736 601 579	■	■	■	■	■		
	LAN-Kabel 2000 everp	8 718 583 686	■	■	■	■	■		
	Außentemperaturfühler neutral everp	8 718 585 355	■	■	■	■	■		
	Wärmeleitpaste 20 ML everp	8 719 918 658 0	■	■	■	■	■		

**GB125 18-60kW V5, MC110**

RMC110  
RMC110  
RMC110  
RMC110

**9B**

**Übersetzungsliste**  
**List of translations**

**Liste des traductions**  
**Traduzione delle descrizioni**

Pos	Description	Denomination	Descrizione		
1	<b>Element of construction</b>	<b>Groupe de construction</b>	<b>Gruppo di costruzione</b>		
1	Boiler Block 6sec mounted	Bloc chaudière 6sec	Corpo caldaia 6sec		
1	boiler block GB125-3sect packed V3	bloc chaudière GB125-3 Gld V3	corpo caldaia GB125-3 Gld V3		
1	Boiler bl GB125-4 sect everp V2 block GB	Corps de chauffe GB125-4 éléments	corpo caldaia GB125-4 Gld V2		
1	Boiler_block GB125 2 sect packed	Corps de chauffe 2 sect	Corpo caldaia 2 sect		
1	Boiler block 5 sec	Bloc chaudière 5 sec	Corpo caldaia 5 sec		
2	Section front 17-34	Élément avant 17-34	Elemento anteriore		
3	Blanking plug G 1 1/4	Raccord aveugle G 1 1/4	Chiusura cieca G 1 1/4		
4	Plug Gasket D41,7x55x1,5 AFM34 sp	Joint D41,7x55x1,5 AFM 34	Guarnizione D41,7x55x1,5 AFM 34		
6	Section middle 17-34	Élément intermédiaire 17-34	Elemento intermedio		
7	Boiler fitting 48/38 Sz 0a repl. pack	Nipple de chaudiere 48/38 T.0A	Nipplo caldaia 48/38 dim.0a		
8	Sealant linseed oil graphit 450g box sp	Minium boite 450g	Ermetizzante 450g		
9	Primer Teroson 1624-24	Apprêt Teroson 1624-24	Primer Teroson 1624-24 Barattolo imball		
10	Rope seal D15x4300 Pack A	Cordon étanch. D15x4300 Pack A 2 RLX	Cordone ermetizzante A		
11	Rear_section 17-34kW	Elément arrière 17-34 kW	Elemento posteriore		
12	Plug G 1	BOUCHON G1	Tappo		
13	Grub screw M10x205 replacem pack	Barre fileté M10x205	Asta filettata M10x205		
14	Gasket D33x44x2mm	Joint D33x44x2mm	Guarnizione		
15	Sensor boiler G1/4 45mm sp	Sonde chaudiere g1/4 45mm	Sonda Caldaia G1/4 45mm		
15	Sensor boiler G1/4 75lg	Sonde chaudiere g1/4 75lg	Sonda caldaia G1/4 75 lun.		
16	Tie rod kit M8x310mm	JEU TIGE D'ANCRAGE M8x310mm	Set tirante M8x310mm		
16	Tie rod kit M8x440mm	Jeu tige d'ancrage M8x440mm	Set tirante M8x440mm		
16	Tie rod kit M8x555mm	Jeu tige d'ancrage M8x555mm	Tirante d'ancoraggio Set M8x555mm		
16	Tie rod set M8x690 cpl	Tige de vis Set	Tirante Set		
16	Tie_rod M8x190 with head packed	Tige de vis Set M8x190	Asta della vite Set M8x190		
17	Feed unit G 1 1/4 18-22KW everp	Tuyau d'alimentation G1 1/4 18-22kW	Tubo di alimentazione		
17	Feed unit G 1 1/4 30-35kW everp	Tuyau d'alimentation G1 1/4 30-35kW	Tubo di alimentazione		
17	Feed unit 5 sect	Tuyau d'alimentation 5 sect	Tubo di alimentazione 5 sect		
18	O-ring 26x3 Set (5x)	JOINT TORIQUE 44x3 (5 X)	Anello di tenuta 44x3 Set (5x)		
19	Baffle GB125 6sec lower	Turbulateur 6sec bas	Turbolatore 6sec sotto		
19	Plate Hot gas baffle	Turbulateur	Turbolatore		
19	Baffle hot gas -2 sect w. lever	Turbulateur	Turbolatore		

**Übersetzungsliste**  
**List of translations**

**Liste des traductions**  
**Traduzione delle descrizioni**

Pos	Description	Denomination	Descrizione		
20	Guide Rail Profile GB125 6sec	Rail 6sec	Rotaia 6sec		
20	Angle profile rail 3sect everp	Angle pour profilé 3 éléments	Profilo angolare		
20	Angle profile rail 4sect everp	RAIL PROFIL EN EQUERRE ELMT	Guida profilata angolare		
20	Angle profile rail 5sect everp	Rail profilé en équerre	Guida profilata angolare		
21	Hinge bracket	Charnière Equerre	Cerniera Angolo		
22	Stand boiler	Pied de la chaudière	Stand boiler		
23	Foot M10x51 (4x)	Pieds réglables M10x51 (4x)	Piedini regolabili M10x51 (4x)		
24	Baffle GB125 6sec upper	Turbulateur haut	Turbolatore sopra 6sec		
24	Baffle hot gas RLU [63028998]	TURBULATEUR RLU [63028998]	Turbolatore RLU [63028998]		
24	Plate hot gaz baffle 5 Sections RLU	Turbulateur 5sec RLU	Turbolatore 5col RLU		
24	Baffle hot gas 2 sect. packed	Turbulateur	Turbolatore		
<b>2</b>	<b>Element of construction</b>	<b>Groupe de construction</b>	<b>Gruppo di costruzione</b>		
1	Burner door GB 60 DE	Porte V2	Porta V2		
1	Burner door GB 18-30 BE sp	porte du brûleur GB 18-30 BE	Porta del bruciatore GB 18-30 BE		
1	Burner door GB 35-49 BE sp	porte du brûleur GB 35-49 BE	Porta del bruciatore GB 35-49 BE		
2	Hinge painted	Charnière	Cerniera		
3	Cover DIN9021 A6,4 A3K packed	Rondelle DIN9021 A6,4 A3K (1x)	Rondella DIN9021 A6,4 A3K (1x)		
4	Viewing hole lock V3 compl.	Viseur flam v3	Chiusura spioncino V3 compl.		
5	Glass pane 30x30x3,3mm repl pack	Verre tempax 30x30x3,3mm v2	Lastra di vetro 30x30x3,3mm		
6	Gasket 30x30x3mm	Joint 30x30x3 (G315)	Guarnizione 30x30x3		
7	Measuring nozz M6 SW10 V2	Injecteur de mesure de press. M6 SW10 V2	Ugello misura della pressione M6 SW10 V2		
8	Packing cords GP14x1650mm long	Cordon d'etancheite gp 14x1650 long	Cordone ermetizzante GP14x1650mm lung.		
9	Sealant brown 310ml	Cartouche mastic pressurise 310	Mastice marrone 310ml imball		
10	Insulation burner door GB125/60	Insulation burner door GB125/60	Isolamento termico porta 60kW		
10	Insulation burner door GB125 18-30 BE sp	Isolation GB125 18-30 BE	Coibentazione GB125 18-30 BE		
10	Insulation burner door GB125 35-49 BE sp	Isolation GB125 35-49 BE	Coibentazione GB125 35-49 BE		
11	Insulation for burner door G/ GB125 sp	Isol porte brul G/GB125	Isolam. Avancorpo porta bruc. G/GB125		
12	Insulation ring burn-door GB125 35-49 sp	Isolation GB125 35-49 BE	isolamento termico GB125 35-49 BE		
12	Insulation ring burn-door GB125 sp	Isolation GB125	isolamento termico GB125		
13	Screw in socket D6 G1/8" SW17	Buse D6 G1/8"	Giunto D6 G1/8"		
<b>3</b>	<b>Element of construction</b>	<b>Groupe de construction</b>	<b>Gruppo di costruzione</b>		
1	Burner hood GB125	Capot bruleur GB125	Cuffia del bruciatore GB125		

**Übersetzungsliste**  
**List of translations**

**Liste des traductions**  
**Traduzione delle descrizioni**

Pos	Description	Denomination	Descrizione		
2	Angle lateral (2 Pieces) everp	Équerre partie	Gomiti		
3	Badge Buderus 186mm	Logo Buderus 186mm	Logo Buderus 186mm		
4	Thermal insulation front 12x580x695	Isol av	Isolamento termico anteriore 12x580		
5	Tie-bar 1,25x108x537	HABIL TRAVERSE	Traversa 1,25x108x537		
5	tie bar 5 sect	Traverse 5 sect	Traversa 5 sect		
7	Side panel 445mm long G125	Habil lat G115/125 3 elm	Seitenwand G125 3Gld kpl everp		
7	Side panel 565mm long G125	Habil lat.G115/G125/G134 4 elm	Seitenwand G125/G134 4Gld kpl everp		
7	Side panel 685mm long G125	HABIL LAT G115/G125-5 ELM/GB125-4 ELM	Seitenwand G125 5Gld kpl everp		
7	Penel side 6 sec blue	Face latérale 6sec	Parete laterale 6sec		
7	Side panel 5sect repla	Face latérale 5 sect	Parete laterale 5 sect		
8	Insulation heat above everp	Isolation thermique haut	Coibentazione sopra		
9	Insulation termal boiler GB125-6sect	Insulation termal boiler 6sect	Isolamento termico corpo caldaia 6sec		
9	Insulation burner block 3 sect	Isolation 3sec	Coibentazione		
9	Insulation burner block 4 sect	Isolation 4sec	Coibentazione		
9	Insulation boiler block GB125-2 sect	Isolation bloc chaudière GB125-2sec	Coibentazione corpo caldaia GB125-2sec		
9	Thermal insul boiblk 5 sect	Isolation 5 sect	Isolamento termico 5 sect		
11	Insulation Clamp (10x)	Ressorts de retenue d 0.8 (10x)	Molla di tenuta (10x)		
12	Hood front G125	Habil facade G125	Copertura ant. G125 compl.		
12	Hood front 5 sect	Capot avant 5 sec	Coperchio anteriore 5 sect		
13	Hood rear G125 3sect	Habil ar G125 3 elm cpl	Pannello copertura hi G125 3Gld compl. i		
13	Hood rear G125 4sect	Habil ar G125 4 elm cpl	Copertura post. G125 4 el. compl		
13	Hood rear G125 5sect	HABIL AR G 125 5 ELM	Copertura post. G125 5 el. compl		
13	Hood rear 6 sec blue	Capot arrière 6sec	Coperchio posteriore 6sec		
13	Hood rear 5 sect	Capot arrière 5 sect	Coperchio posteriore 5 sect		
14	Conn hood blue	Capot bleu	Coperchio blu		
16	Insulation rear panel	Isolation panneau arriere	Coibentazione parete posteriore		
17	Cable clip (5x)	ATTACHE RAPIDE (5x)	Angolare (5x)		
18	Burner cable 2350 1-step	Câble de brûleur 2350mm	Linea del bruciatore 2350mm		
19	Connector 7-pole BR I green	Borne de connexion 7- pôles BR I vert	Morsetto collegamento bruciatore 7-poli		
20	Connector part ST18/7 silver-plated	Connect st18/7 argente	Connessione a spina ST18/7 argentata		
21	Edge protection kit 65+80+160lg	PROTECT BORDS 65/80/160	edge guard		
23	Angle rear panel V3 packed	Équerre V3	Gomiti V3		

**Übersetzungsliste**  
**List of translations**

**Liste des traductions**  
**Traduzione delle descrizioni**

Pos	Description	Denomination	Descrizione		
24	Cable penetration everp	Passe-câbles	Passacavo		
25	Pan-head screw ST3,9x9,5 A3T (10x)	Vis à tête plate ST3,9 (10x)	Vite a testa piana ST3,9x9,5 (10x)		
26	Back_panel top V2 packed	Panneau arrière haut	Parete posteriore sopra		
27	Back_panel bottom part V4 packed	Panneau arrière bas	Parete posteriore sotto		
28	Rear panel 5 sect	Panneau arrière 5 sect	Parete posteriore 5 sect		
<b>4</b>	<b>Element of construction</b>	<b>Groupe de construction</b>	<b>Gruppo di costruzione</b>		
1	Heat_exchanger sec system 30-60 V2	Échangeur thermique 30-60	Scambiatore di calore		
1	Heat_exchanger sec system 18-22 V2	Échangeur thermique 18-22 V2	Scambiatore di calore		
3	cover fluegas distrib 18-22 AL V3 sp	Couvercle collecteur de combustion 18-22	Guarnizione distribut gas combusto 18-22		
3	Cover fluegas distrib 30-60 AL V2 sp	Couvercle collecteur de combustion 30-60	Guarnizione distribut gas combusto 30-60		
4	Fasteners	Fixation rapide	Chiusura rapida		
5	Gasket fibre section/flue gas adapter ev	Joint élément arrière	Guarnizione elemento posteriore		
6	Screw set	Vis-Set	Vite		
9	Return pipe HK/WT G1 V3 packed	Tube retour HK/WT G1	Tubo di ritorno HK/WT G1		
9	Return pipe HK/WT G1 1/4 V3 packed	Tube retour HK/WT G1 1/4	Tubo di ritorno HK/WT G1 1/4		
10	Return pipe RK/WT G1 everp V2 pipe RK/WT	Tube retour RK/WT G1	Tubo di ritorno		
10	Return pipe RK/WT G11/4 V2 everp	Tube retour RK/WT G1 1/4 V2	Tubo di ritorno		
11	Gasket D21X30X3, DVGW-ZUGEL (5x) everp	Joint D21x30x3 (5x)	Guarnizione (5x)		
15	O-ring 21,89x2,62 70EPDM everp (5pcs)	Joint torique 21,89x2,62 70EPDM	Anello di tenuta		
15	O-ring 28x3 70EPDM/281	JOINT CONDENSEUR V2 GB 125 30-35 KW	O-ring 28x3		
16	Air vent 1/8 bsp	Purgeur 1/8 BSP	AIR VENT 1/8 BSP		
19	lips seal d80 PerOxyd (5x)	Joint a levre DN80 peroxyde (5x)	Guarniz. ad anello spigolo tenutaDN80 5x		
20	Sensor holder (2x)	FIXATION SONDE (2x)	Alloggiamento della sonda (2x)		
21	Gas sensor D29/d6 60mm	Sonde de temperature de fumee 60mm	Sonda gas combusti D29/d6 60 lung.		
22	O-ring 6x2 ISO 3601 FKM (3pc)	Joint torique 6x2 ISO 3601 FKM (3x)	O-ring 6x2 ISO 3601 FKM (3x)		
24	Siphon-Set V4 sp	Siphon-Set	Sifone-Set		
27	Extension G1x120 V2	Rallonge G1x120 V2	Prolunga		
28	O-ring 35x3 Set (5x)	Joint torique 35x3 Set (5x)	Anello di tenuta 35x3 Set (5x)		
29	Bracket siphon GB125 V4 packed	Support Siphon V4	Supporto Siphon V4		
30	Cable clip	Support	Supporto		
31	Insulation WT 18-22 kW	Isolation WT 18-22	Coibentazione		
31	Insulation WT 30-35 kW	Isolation WT 30-35	Coibentazione		

**Übersetzungsliste**  
**List of translations**

**Liste des traductions**  
**Traduzione delle descrizioni**

Pos	Description	Denomination	Descrizione		
33	Flue gas adapter RC250C packed	Raccordement chaudière bas RC250C	Attacco caldaia sotto RC250C		
34	Seal Flue gas 30-35 Al everp	Joint gas 30-35 Al	Guarnizione		
34	Seal flue gas distribution 18-22KW AL ev	Joint 18-22kW	Guarnizione		
36	spring clip d=32,6/22 everp clip d=32,6/	Pince à ressort d=32,6/22	Molla		
36	Spring d=38,2/28	Pince à ressort d=38,2/28	Molla		
37	Spring plug D26 everp plug D26 everp	Fiche à ressort D26	Molla ad innesto D26		
38	isolation thread rod 36,2 rpack	Isolation barre fileté 36,2	Isolamento asta filettata 36,2		
38	Sleeve 17,2x2,1x63,5 packed	Entretoise 17,2x2,1x63,5	Distanziale 17,2x2,1x63,5		
39	Conn union 2/3 R3/4" everp	Raccord sonde sanitaire 2/3 R3/4"	Raccordo 2/3 R3/4"		
39	Hose connector G3/4x20 angled	Embout G3/4x20 équerre	Raccordo ad innesto per tubo flessibile		
40	Tube set DN20 DN20 (3m)	Tuyau DN20 (3m)	Tubo flessibile DN20 (3m)		
41	Tee	Kit depart	RACC. A T COMPL.		
41	T-connect 60 kW sp	T-connect 60 kW sp			
42	Seal D18x30x2 EPDM packed	joint	Guarnizione		
43	Seal D27x38x2 DVGW packed	Joint D27x38x2mm C4400 Klinger SIL	Guarnizione 27x38x2mm C4400 Klinger SIL		
45	Wire Data ext. Gassensor 330 everp	Câble	Cavo		
48	Sealing-Set Siphon	Kit de joints pour siphon	Set guarnizioni sifone		
<b>5</b>	<b>Element of construction</b>	<b>Groupe de construction</b>	<b>Gruppo di costruzione</b>		
2	Wire Burner Oil BE 2.3-60 K RLA	brûleur fioul BE 2.3-60 K RLA	bruciatore a gasolio BE 2.3-60 K RLA		
2	Burner Oil BE 1.3-18 cpl V3 sp	brûleur fioul BE 1.3-18 kpl V3	bruciatore a gasolio BE 1.3-18 kpl V3		
2	Burner Oil BE 1.3-22 cpl V3 sp	Brûleur fioul BE 1.3-22 V3	bruciatore a gasolio BE 1.3-22 kpl V3		
2	Burner Oil BE 2.3-30 cpl V3 sp	brûleur fioul BE 2.3-30 kpl V3	bruciatore a gasolio BE 2.3-30 kpl V3		
2	Burner Oil BE 2.3-35 cpl V3 sp	brûleur fioul BE 2.3-35 kpl V3	bruciatore a gasolio BE 2.3-35 kpl V3		
2	Burner Oil BE 2.3-49 cpl V3 sp	brûleur fioul BE 2.3-49 kpl V3	bruciatore a gasolio BE 2.3-49 kpl V3		
5	Service-Set BE 18kW everp	Set de service BE 18kW	Imballato BE 18kW		
5	Service-Set BE 22kW everp	Set de service BE 22kW	Imballato BE 22kW		
5	Service-Set BE 30kW everp	Set de service BE 30kW	Imballato BE 30kW		
5	Service-Set BE 35kW everp	Set de service BE 35kW	Imballato BE 35kW		
5	Service-Set BE 49kW everp	Set de service BE 49kW	Imballato BE 49kW		
5	Service-Set BE 60kW everp	Set de service BE 60kW	Imballato BE 60kW		
<b>6</b>	<b>Element of construction</b>	<b>Groupe de construction</b>	<b>Gruppo di costruzione</b>		
1	Motor HG 150W without Clutch	Moteur hg 150w avec accoupl	Motor HG 150W everp		



**Übersetzungsliste**  
**List of translations**

**Liste des traductions**  
**Traduzione delle descrizioni**

Pos	Description	Denomination	Descrizione		
1	Motor HG 170W without Clutch	Moteur hg 170 w	Motore HG 170W		
2	capacitor 4MF, 400V AEG	Condensateur 4MF, 400V AEG	Condensatore 4MF, 400V AEG		
2	capacitor 5MF	Condensateur 5MF	Condensatore 5MF		
3	Clutch white (2x)	Accoupl mot.- pompe fioul 2 meplats(2x)	Accoppiamento bianco (2x)		
4	Cylinder head screw DIN912 M5x12 (10x)	VIS CYLINDRIQUE DIN912 M5x12 (10x)	Cylinder head screw DIN912 M5x12 (10x)		
5	Stud Threaded M8x25/D13/ K105	BOULON FILETE M8x25/D13/ K105	Bullone filettato M8x25/D13/ K105		
6	cabl e feed D 14/4mm	PASSE FIL D 14/4MM	Passacavo D 14/4mm		
7	Pressure test nozzle R 1/8" MS	BUSE MESURE R 1/8	Nipplo di prova pressione R1/8" Ms		
8	cabl e feed D 29x11x4	Passe fill D 29x11x4	Passacavo D 29x11x4		
9	Pin threaded DIN916 M6x8 (3x)	Tige filetée DIN916 M6x8 (3x)	Perno filettato DIN916 M6x8 (3x)		
10	Cylinder-head screw DIN7984 M8x25 8.8 A3	VIS A TETE CYLINDRIQUE DIN7984 M8X25 8.8	Cylinder-head screw DIN7984 M8x25 8.8 A3		
11	Distribution cylinder HG-A V1	Cylindre distributeur HG-A 17,34	Collettore distr. cilindrico HG-A V1		
11	Distribution cylinder HG-A for 45,55kW	DEFLECTEUR D'AIR HGA 45-55 KW	Cilindro di distribuzione HG-A V2		
11	Distribution cylinder HG-A radial 4,9	REPART AIR CYLINDRE DISTR.	Distribution cylinder HG-A radial 4,9		
12	O-ring 92x3	Joint etancheite d 93x3 mm4	O-Ring 92x3 Viton everp		
13	gasket D128x2	Joint D128x2	Guarnizione D128x2		
14	Burner flange HG-A	BRIDE DE BRULEUR HG-A	Flangia HG-A		
15	gasket 143x143x6 V3	Joint 143x143x6 V3	Guarnizione 143x143x6 V3		
16	impeller D133x38,4mm	Turbine extracteur D133x38,4mm	Ventola del ventilatore D133x38,4mm		
16	impeller D133x59,8mm	Turbine extracteur D133x59,8mm	Ventola del ventilatore D133x59,8mm		
17	Housing lid HG-A size 1	Couvercle HG-A Gr. 1	Coperchio HG-A Gr. 1		
17	Housing lid HG-A size 2	Couvercle HG-A Gr. 2	Coperchio HG-A Gr. 2		
18	Screw Pan-Head ISO7380 M5x20 (5x)	Vis à tête bombée ISO7380 M5x20 (5x)	Vite a testa bombata ISO7380 M5x20 (5x)		
19	Inlet air duct HG-A size 1	DEFLECTEUR ASPIRATION HG-A MOD1 17-28KW	Inlet air duct HG-A size 1		
19	Inlet air duct HG-A size 2	DEFLECTEUR ASPIRATION HG-A MOD2 34KW	Inlet air duct HG-A size 2		
20	Inlet silencer HG-A RLU	Silencieux aspiration hg a RLU	Silenziatore HG-A RLU		
21	Silencer suction HG-A V3 cpl	Silencieux aspiration HG-A V3 cpl	Silenziatore HG-A V3 cpl		
22	Screw Pan-Head ISO7380 M5x8 (5x)	Vis à tête bombée ISO7380 M5x8 (5x)	Vite a testa bombata ISO7380 M5x8 (5x)		
23	Hose air WaBi Santo DN63 L1600 packed	tuyau flexible pour air WaBiSanto DN63 L	tubo blesabile aria WaBiSanto DN63 L160		
24	Clamp hose 60/80 packed	Collier de serrage 60/80	Fascette stringitubo spirale 60/80 imba		
25	Switch DL 10KH-5 Z 290/70 cpl sp	contrôleur pression DL 10KH-5 Z 290/70	Pressostato DL 10KH-5 Z 290/70		
26	hose pressure switch	JEU DE FLEXIBLE BLEU/ ROUGE	Tubo flessibile (set)		

**Übersetzungsliste**  
**List of translations**

**Liste des traductions**  
**Traduzione delle descrizioni**

Pos	Description	Denomination	Descrizione		
27	Screw Pan- Head ISO7380 M5x16 (5x)	Vis à tête bombée ISO7380 M5x16 (5x)	Vite a testa bombata ISO7380 M5x16 (5x)		
28	Switch DL 10KH-5 Z 100/70 cpl sp	contrôleur pression DL 10KH-5 Z 100/70	Pressostato DL 10KH-5 Z 100/70		
28	Switch DL 10KH-5 Z 140/70 cpl sp	Contrôleur pression DL 10KH-5 Z 140/70	Pressostato DL 10KH-5 Z 140/70		
29	hose pressure switch GB125 sp	JEU DE FLEXIBLE BLEU/ ROUGE GB125	Tubo flessibile (set) GB125		
<b>7</b>	<b>Element of construction</b>	<b>Groupe de construction</b>	<b>Gruppo di costruzione</b>		
2	Housing Terminal cover SAFe	Couvercle safe GB402	Coperchio SAFe		
3	Control_box SAFe30 V7 DNA SP	SAFe30 V7 DNA	SAFe30 V7 DNA		
4	Housing lower section SAFe	BOITIER ARRIERE SAFE	Involucro Parte inferiore SAFe		
5	Adapter H05V-K 0,75 0,8/2,0 gn/ge	Adaptateur H05V-K 0,75 0,8/2,0 gn/ge	Adattore H05V-K0,75 0,8/2,0 gn/ge		
6	Module BIM30 V10 GB125-60 everp	module BIM30 V10 GB125-60	Modulo BIM30 V10 GB125-60		
6	Module BIM30*-LoI/01 V10 18-49	Module BIM30*-LoI/01 V10 18-49	Modulo BIM30*-LoI/01 V10 18-49		
8	Connection line SAFe motor BE	CABLE SAFE - MOTEUR	Tubazione di collegamento SAFe-Motore BE		
8	Cable Motor 380 everp	câble de connexion Moteur 380	tubazione di collegamento Motore 380		
9	Cable Ignition 410 everp	câble de connexion allumage 410	tubazione di collegamento accensione 410		
9	Ignition cable SAFe 230 V	Cable allumage - safe	Cavetto accensione SAFe 230V		
10	Connection line Oil pre-heater SAFe BE	Cable rechauffeur - safe	Tubazione di collegamento SAFe BE		
10	Cable Oil heater 375 everp	Cable rechauffeur 375	Tubazione di collegamento 375		
12	UV-flaming sensor QRC SAFe BZ/BE_3	Detect flam qrc safe BZ/BE	UV-flaming sensor QRC SAFe BZ/BE_3		
13	Support pipe extension BE_3 RLU V2	Tube de vise cellule BE_3 RLU V2	Support pipe extension BE_3 RLU V2		
14	Pipe holds HG V4 everp	TUBE MAINTIEN HG V4 BRULEUR BE	Holds pipe HG V4		
15	igniter sensor cable BE/BE-A	Cable allumBE /BE-A	Cavetto accensione BE/BE-A		
15	Ignition Reaktanz 1550 Ohm 275mm everp	CABLE ALLUM Reakt. 1550 Ohm 275mm	Cavetto accensione Reakt. 1550 Ohm 275mm		
16	Ignition Danfoss EBI V4 spare part	Transformateur allumage ebi danfoss v4	Dispositivo di accensione Danfoss EBI V4		
17	Data cable SAFe MC10 BE	Cable bus safe - MC10	Tubazione di collegamento SAFe MC10 BE		
18	Con cable sensor SAFeBE grommet	Cable safe - sonde chaudiere	Tubazione di collegamento SAFe BE		
18	Cable sensor SAFe 1900 everp	Capteur SAFe 1900	Sensore SAFe 1900		
19	Cable SAFe Power 1250 everp	câble de réseau SAFe 1250	cavo di rete SAFe 1250		
20	Cable MV 1 Pressure 320/580 everp	câble de connexion imprimer 320/580	tubazione di collegamento stampa 320/580		
<b>8B</b>	<b>Element of construction</b>	<b>Groupe de construction</b>	<b>Gruppo di costruzione</b>		
1	Pump Oil Suntec ALEV35C everp	Pompe fioul suntec alev 35c	Pompa olio Suntec ALEV35C imball		
1	Pump oil Suntec ALEV55C everp	Pompe fioul suntec alev 55c	Pompa olio Suntec ALEV55C imball		
2	solenoid coil Suntec 220-240V/50-60Hz	Bobine electrovanne pompe suntec	Bobina magnetica Suntec 220-240V/50-60Hz		

**Übersetzungsliste**  
**List of translations**

**Liste des traductions**  
**Traduzione delle descrizioni**

Pos	Description	Denomination	Descrizione		
3	filter oil pump A70 Rev.3 AS 47 (2x)	Filtre Pompe à fioul A70 Rev.3 AS47 (2x)	Filtro Pompa gasolio A70 Rev.3 AS47 (2x)		
4	gasket oil pump ALE 35/55 (2x)	JOINT COUVERCLE POMPE SUNTEC AS 47 (2x)	Guarnizione Pompa gasolio ALE 35/55 (2x)		
5	Hose set BE/RE	Conduit flexible set BE	Tubo flessibile (set) BE / RE		
6	Screw connection XGE 4LLR 1/8" cyl.	RACC DROIT VIS XGE 4 LLR 1/8"	Raccordo XGE 4LLR 1/8"		
7	Oil_pipe HG-A	TUBE ALIM FIOUL HG-A	Oil pipe HG-A		
8	Coil solenoid BFP 21/31 L3	Bobine electrovan bfp 31 I3 pompe danfos	Bobina BFP 21/31 L3		
9	filter oil pump BFP 21/31 L3 (2x)	Filtre pompe fioul danf bfp 21/31 I3 (2x)	Filtro Pompa gasolio BFP 21/31 L3 (2x)		
10	Clutch white (2x)	Accoupl mot. - pompe fioul 2 meplats(2x)	Accoppiamento bianco (2x)		
11	Screw connection 3/8x1/4" straight	RACCORD 3/8"X1/4",DROIT	Raccordo 3/8x1/4"		
12	Washer 13x18x1,5 (5x)	Joint 13x18x1,5 (5x)	Guarnizione 13x18x1,5 (5x)		
<b>9A</b>	<b>Element of construction</b>	<b>Groupe de construction</b>	<b>Gruppo di costruzione</b>		
1	disc D9,5/14x4 Ver02	RONDELLE D9,5/14X4 VER02	Rondella D9,5/14x4 Ver02		
2	Compres spring DIN2098 1,8x12,5x36	RESSORT DIN2098 1,8x12,5x36	Molla antagonista DIN2098 1,8x12,5x36		
3	Preheater oil FPHE-LE 030N5129 PTC50	Prechauffeur fioul FPHE-LE 030N5129PTC50	preriscaldatore olio FPHE-LE PTC50		
3	Preheater oil FPHB5-LE PTC70 B10	Brul rechauff fphb 5/30n	Preriscaldatore olio FPHB5-LE PTC70 B10		
4	Cut-off valve LE6 sp	Clapet retenu le6	Valvola a membrana LE6		
5	Nozzle oil 0.55gph 60gr HR Danfoss everp	gicleur fioul 0.55gph 60gr HR Danfoss	ugello per gasolio 0.55gph 60gr HR Danfo		
5	oil nozzle 1,00gph 60° H Danfoss	Gicleur fioul 1,00gph 60° H Danfoss	ugello per gasolio 1,00gph 60° H Danfoss		
5	oil nozzle 0,45gph80Gr HFD Danfoss	Gicleur 0,45/80° HFD (danfoss)	ugello per gasolio 0,45gph80Gr HFD Danfo		
5	oil nozzle 0,85gph 60° H	Gicleur fioul 0,85gph 60° H	ugello per gasolio 0,85gph 60° H		
5	Oil nozzle 0,35gph 80Gr HR	Gicleur 0,35/80° hr	Ugello per gasolio 0,35gph 80Gr HR		
5	Oil nozzle 0,45gph80Gr HFD Danf.(12x)	Gicleur fioul 0,45gph80Gr HFD Danf.(12x)	Ugello per gasolio 0,45gph80Gr HFD (12x)		
5	Oil nozzle 0,35gph80Gr HR Danf(10x)	Gicleur fioul 0,35gph80Gr HR Danf(10x)	Ugello per gasolio 0,35gph80Gr HR (10x)		
5	Nozzle for Oil 0.65gph 80°	Injecteur 0.65gph 80°	Ugello 0.65gph 80°		
5	Oil Nozzle 0,55gph 60Gr HR Danfoss10Pack	Oil Nozzle 0,55gph 60Gr HR Danfoss10Pack	Ugello olio 0,55gph 60Gr HR Danfoss(10x)		
6	Mixer system BE 12,0/25,0/5,0/25	Chambre de melange BE 12,0/25,0/5,0/25	Modulo di miscelazione BE 12,0/25,0/5,0		
6	Mixer system BE BE 12,1/27,5/5,8/25	SYSTEME DE MELANGE BE POUR GB125 22KW	Modulo di miscelazione BE 12,1/27,5/5,8		
6	Mixer system BE 12,1/27,5/6,9/25 VA	SYSTEME DE MELANGE BE POUR GB125 30KW	Modulo di miscelazione BE 12,1/27,5/6,9		
6	Mixer system BE 12,4/27,5/8,3/25 VA	SYSTEME DE MELANGE BE POUR GB125 34KW	Modulo di miscelazione BE 12,4/27,5/8,3		
6	Mixer system BE/BE-A 2.1-43/45kW	SYSTEME MELANGEUR BE/ BE-A 2.1-43/45	Sistema di miscelazione BE/ BE-A 2.1-43/4		
6	Mixer system BE-55kW	SYSTEME MELANGEUR BE -55KW	Sistema di miscelazione BE-55kW		
7	ignition electrode BE-BE-A Typ4 L34	Electrode d'allumage BE-BE-A Typ4 L34	Elettrodo accensione BE-BE-A Typ4 L34		

**Übersetzungsliste**  
**List of translations**

**Liste des traductions**  
**Traduzione delle descrizioni**

Pos	Description	Denomination	Descrizione		
7	Ignition electrode BE Type 4 L50 V2	Électrode d'allumage BE Typ4 L50 V2	Elettrodo di accensione BE Typ4 L50 V2		
7	Ignition electrode BE T4 L58,5 V2	électrode d'allumage BE T4 L58,5 V2	elettrodo di accensione BE T4 L58,5 V2		
8	Screw cheese-head DIN 912 M4x10 (5x)	VIS A TETE CYLINDRIQUE DIN912 M4X10 (5X)	Screw cheese-head DIN 912 M4x10 (5x)		
9	Sealing D75,5 V2	Joint tuyere BE 1.0/1.1/2.0/2.1	GUARNIZIONE BOCCAGLIO - RC		
9	Seal D81 V2 everp	JOINT DE TUYERE D81 V2	Dichtung D81 V2		
10	Blast tube D69/L214 18kW	Tuyere 69/I214 sic 18kw	Raccordo bruciatore D69/L214 SiC 18kW		
10	Blast tube D83/L214 25kW	Tuyere GB125BE 25kw	Raccordo bruciatore D83/L214 25kW		
10	blast tube D83/L224/5,9/4,8 SiC	Tuyere GB125 BE 30kw	Boccaglio D83/L224/5,9/4,8 SiC		
10	blast tube D83/L224/7,0/5,7 SiC	Tuyere GB125 BE 125 35 kw	Boccaglio D83/L224/7,0/5,7 SiC		
10	Blast tube D83/L224/5,7/5,4 SiC	Tuyere d83/I224/5,7/5,4 sic	Boccaglio D83/L224/5,7/5,4 SiC		
11	Screw Pan-Head ISO7380 M5x8 (5x)	Vis à tête bombée ISO7380 M5x8 (5x)	Vite a testa bombata ISO7380 M5x8 (5x)		
12	Support tube L50	TUBE DE SUPPORT L50	Support tube L50		
13	O-ring 92x3	Joint etancheite d 93x3 mm4	O-Ring 92x3 Viton everp		
14	Burnertube D96/L257,5/5,5/4,9/4,9-8 eve	TUYERE GB225/55kW	Boccaglio D96/L257,5/5,5/4,9/4,9-8		
	Installation material oil burner BE	Matériel de montage Brûleur fioul BE	Materiale per il montaggio Bruciatore a		
<b>9B</b>	<b>Element of construction</b>	<b>Groupe de construction</b>	<b>Gruppo di costruzione</b>		
2	Screw M 3.5 x 12 (6x)	Vis M 3.5 x 12 (6x)	Vite M 3,5 x 12 (6x)		
3	Housing upper part blue	Carter partie superieure bleu	Parte superiore involucro blu		
4	Housing module carrier white	Module plaque de jonction blanc	Modulo Supporto bianco		
5	Fuse application 5x20 6,3AT 230V (10x)	Fusible arrière 5x20 6,3AT 230V (10x)	Fusibile posteriore 5x20 6,3AT 230V(10x)		
6	Fuseholder cap	Support de fusible	Porta fusibile		
7	Connector 3-pole white	Borne de connexion 3- pôles blanc	Morsetto di collegamento 3-bipol. bianco		
8	Connector 3-pol. SF50 pink	Borne de raccordement 3-poles SF50 rose	Morsetto di collegamento 3-pol.SF50 rosa		
9	Wire Power HV 1270 Ferrit everp	faisceau de câbles Power HV 1270 Ferrit	Cablaggio Power HV 1270 Ferrit		
11	Connector 4-pol 17B18 orange	Borne de raccordeme 4 poles 17B18 orange	Morsetto di collegamento 4-pol. 17B18		
12	Connecting terminal pluggable 3-pol	Borne de connexion 3- pôles jaune	Morsetto di collegamento 3-bipol. giallo		
13	Connector 4-pole SH I violet	Borne de connexion 4- pôles SH I violet	Morsetto di collegame.4-bipol.SH I viol.		
14	Connector 3-pole PS grey	Borne de connexion 3- pôles ps gris	Morsetto di collegamento 3-pol.PS grigio		
15	Connector 3-pole PZ violett	Connecteur 3 poles violet	Morsetto di collegamento - pol.PZ violett		
16	Connector 3-pole PH green	Borne de connexion 3- pôles PH vert	Morsetto di collegamento 3-pol. PH verde		
18	Connector 3-pol. AS red sparepart	Borne de raccordement 3-poles AS rouge	Morsetto di collegamento3-bipol.AS rosso		
19	Connecting terminal 2-polig WA maygreen	Fiche verte 2 poles wa	Morsetto di collegamento2-bipol WA verde		

**Übersetzungsliste**  
**List of translations**

**Liste des traductions**  
**Traduzione delle descrizioni**

Pos	Description	Denomination	Descrizione		
20	Connector 2- pin blue	Borne de connexion 2- pol r5 bl everp	Morsetto di collegamento 2- bipolare blu		
21	Connector 2-pole grey FW	Borne de connexion 2- pôles gris FW	Morsetto di collegame.2-bipol. grigio FW		
22	Connect. term. 2-polig red	Fiche rouge 2 poles	Morsetto di collegamento2- bipolare rosso		
23	Connector 2- pin orange RC	Borne de connexion 2- pôles orange RC	Morsetto di collegamento2- bip.arancione		
24	Connector 2-pole white	Borne de connexion 2-poles blanc	Morsetto di collegamento2-pol bianco		
30	Housing strain relief control (10x)	Décharge de traction (10x)	Fermo antitrazione (10x)		
31	Printed circuit board MC110 S14 blue	Circuit imprimé MC110 S14 bleu	Circuito stampato MC110 S14 blu		
34	Strand set bus BC110-IMC110	Jeu de câbles Bus BC110-IMC110	Set di cavi Bus BC110-IMC110		
35	Control_panel BC110 S04	Module de commande BC110 S04	Controllo remoto BC110 S04		
36	Housing flap BC110	Couvercle BC110	Coperchio BC110		
55	Cover RC3xx black	Revêtement RC3xx noir	Pannello protettivo RC3xx nero		
	Temperature sensor RD 6,0 10k# 3000mm	Sonde de température RD6,0 10kOHM 3000mm	Sonda di temperatua RD 6,0 10k# 3000mm		
	Buderus Logamatic MC110 S14 blue	Buderus Logamatic MC110 S14 blau verp	Buderus Logamatic MC110 S14 blu verp		
	LAN-Cable RJ45 Cat.5 2000	LAN-câble 2000	LAN-Cavo 2000		
	Outdoor temperature sensor	Sonde de température extérieure	Sonda temperatua esterna		
	Heat conducting paste 20 ML	Pate Thermocond. 20 ML.	Pasta termoconduttrice 20 ML		

**Gerätetypen**  
**Types of appliances**

**Types de chaudières**  
**Tipo apparecchi**

Gerät Appliance Chaudière Apparecchio	Bestell-Nr. Ordering no. Numéro de commande N° d'ordine	Land Country Pays Paese	Bemerkungen Remarks Remarques Osservazioni
GB125-18	7 736 604 145	Belgien, Deutschland, Estland, Griechenland	
GB125-22	7 736 604 146	Belgien, Deutschland, Estland, Griechenland	
GB125-30	7 736 604 147	Belgien, Deutschland, Estland, Griechenland	
GB125-35	7 736 604 148	Belgien, Deutschland, Estland, Griechenland	
GB125-49	7 736 604 149	Belgien, Deutschland, Estland, Griechenland	
GB125-60	7 736 604 150	Belgien, Deutschland, Luxemburg, Schweiz, Ös	

Bosch Thermotechnik GmbH  
Sophienstr. 30-32  
D-35576 Wetzlar / Germany

**Buderus**