



Ihr Online-Fachhändler für:



Buderus

- Kostenlose und individuelle Beratung
- Hochwertige Produkte
- Kostenloser und schneller Versand

- TOP Bewertungen
- Exzelerter Kundenservice
- Über 20 Jahre Erfahrung



E-Mail: info@unidomo.de | Tel.: 04621 - 30 60 89 0 | www.unidomo.de

Montage-Set SKT1.0/FKT2

Installation-set SKT1.0/FKT2



[de] Wichtige Hinweise zur Installation/Montage

Die Installation/Montage muss durch eine für die Arbeiten zugelassene Fachkraft unter Beachtung der geltenden Vorschriften erfolgen.

[en] Important notes on installation/assembly

The installation/assembly must be carried out by a qualified contractor, following these instructions and in compliance with the applicable regulations.

[fr] Instructions importantes pour l'installation/le montage

L'installation/le montage doit être effectué(e) par un spécialiste qualifié pour les opérations concernées et dans le respect de la présente notice et des prescriptions applicables.

[bg] Важни указания във връзка с инсталацията/монтажа

Инсталацията/монтажът трябва да се извършва от лицензиран за работите специалист в съответствие с настоящото ръководство и с приложимите разпоредби.

[cs] Důležité pokyny k instalaci/montáži

Instalaci/montáž musí při dodržení pokynů uvedených v tomto návodu a platných předpisů provést odborný pracovník s příslušným oprávněním pro tyto práce.

[da] Vigtige anvisninger til installationen/monteringen

Installationen/monteringen skal foretages af en godkendt installatør under overholdelse af denne vejledning og de gældende forskrifter.

[el] Σημαντικές υποδείξεις για την εγκατάσταση/συναρμολόγηση

Η εγκατάσταση/τοποθέτηση πρέπει να ανατίθεται σε εκπαιδευμένο για τις συγκεκριμένες εργασίες τεχνικό προσωπικό με τήρηση αυτών των οδηγιών καθώς και των σχετικών προδιαγραφών.

[es] Indicaciones importantes para instalación/montaje

La instalación/el montaje debe realizarla personal especializado que esté autorizado para realizar estos trabajos y que tenga en cuenta estas instrucciones y la normativa vigente.

[et] Olulised juhised paigaldamiseks/montaažiks

Paigaldamist/montaaži tohib läbi viia vaid selleks volitusi omav spetsialist, arvestades kehtivaid nõudeid.

[nl-BE] Belangrijke aanwijzingen betreffende de installatie/montage

De installatie/montage moet worden uitgevoerd door een voor de werkzaamheden geautoriseerde installateur rekening houdend met deze handleiding en de geldende voorschriften.

[fi] Tärkeitä asennus- ja kokoonpano-ohjeita

Näihin töihin hyväksytyin ammattiasentajan pitää suorittaa asennus- ja kokoonpanotyöt voimassa olevien määräysten mukaisesti.

[hu] Fontos tudnivalók az installálás/szereléshez

A telepítést/szerelést egy, a munkálatokra felhatalmazott szakembernek kell végeznie, jelen utasítás és az érvényes előírások figyelembevételével.

[it] Avvertenze importanti per l'installazione/il montaggio

L'installazione/il montaggio deve aver luogo ad opera di una ditta specializzata ed autorizzata in osservanza di queste istruzioni e delle direttive vigenti.

[ka] მნიშვნელოვანი მითითებები ინსტალაციისთვის/მონტაჟისთვის

ინსტალაცია/მონტაჟი უნდა განხორციელდეს საშუალებისთვის დამკვეთი კვალიფიციური პერსონალის მიერ, მოქმედი განაწესის დაცვით.

[lt] Svarbios instaliavimo ir (arba) montavimo nuorodos

Instaliavimo / montavimo darbus, laikydamiės šios instrukcijos reikalavimų ir galiojančių taisyklių, privalo atlikti šioms darbams įgalioti specialistai.

[lv] Svarīgi norādījumi par iekārtas uzstādīšanu / montāžu

Uzstādīšanu/montāžu jāveic atbilstošajiem darbiem sertificētam speciālistam, ievērojot šo instrukciju un spēkā esošos noteikumus.

[nl] Belangrijke aanwijzingen betreffende de installatie/montage

De installatie/montage moet door een erkend installateur volgens de geldende voorschriften worden uitgevoerd.

[no] Viktig informasjon om installasjon/montering

Installasjonen/monteringen skal gjennomføres av autoriserte installatører, og installasjonsanvisningen samt gjeldende forskrifter skal følges.

[pl] Ważne wskazówki dotyczące instalacji/montażu

Instalację/montaż powinien wykonać specjalista uprawniony do tego typu prac z uwzględnieniem informacji podanych w niniejszej instrukcji oraz aktualnie obowiązujących przepisów.

[pt] Indicações importantes relativas à instalação/montagem

A instalação/montagem deve ser efectuada por um técnico autorizado para os trabalhos, respeitando este manual e as prescrições válidas.

[ro] Indicații importante privind instalarea/montajul

Instalarea/montajul trebuie realizate de către un specialist autorizat pentru lucrările respective, respectându-se prezentele instrucțiuni și prescripțiile valabile.

[ru] Важные указания по подключению/монтажу

Подключение/монтаж должны выполнять только специалисты, имеющие допуск к выполнению таких работ, при соблюдении требований этой инструкции и действующих норм и правил.

[sk] Dôležité pokyny týkajúce sa inštalácie/montáže

Inštaláciu/montáž musí vykonať odborný personál, ktorý má oprávnenie pre výkon týchto prác, pričom musí dodržiavať pokyny uvedené v tomto návode a platné predpisy.

[sl] Pomembni napotki za namestitvev/montažo

Inštalacijo/montažo lahko izvede samo pooblaščen strokovnjak ob upoštevanju teh navodil in veljavnih predpisov.

[sr] Važna uputstva za ugradnju i montažu

Ovu instalaciju/montažu moraju da obave stručna lica koja su ovlašćena za obavljanje takvih radova u skladu sa ovim uputstvom i važećim propisima.

[sv] Viktiga anvisningar för installation/montering

Installationen/monteringen måste utföras av en behörig och tekniskt utbildad person enligt denna anvisning samt gällande föreskrifter.

[tr] Kurulum/Montaj ile ilgili önemli uyarılar

Kurulum/montaj, bu çalışmalarını yapmasına müsaade edilen uzman kişiler tarafından işbu kılavuz ve geçerli yönetmelikler dikkate alınarak yapılmalıdır.

[uk] Важливі вказівки щодо установки/монтажу

Встановлення/монтаж повинні виконувати фахівці, що допущені до виконання таких робіт, із дотриманням цієї інструкції та діючих приписів.

[zh] 安装方面的重要提示

安装和组装工作必须由经过许可的专业人员进行, 同时必须遵守本说明书和现行法规的相关要求

[ar] ملاحظات هامة للتركيب/التجميع
يجب أن يتم التركيب/التجميع من قبل متخصص مصرح له بالعمل، مع مراعاة اللوائح السارية.

[fa] تذکرات مهم درباره نصب/مونتاژ
نصب/مونتاژ باید توسط فردی حرفه ای که مجاز به انجام این کار است، و همچنین با توجه کامل به مقررات مربوطه انجام شود.

[az] Quraşdırılma

Quraşdırılma işinin yerinə yetirilməsi səlahiyyətli bir mütəxəssis tərəfindən və müvafiq qaydalara uyğun olaraq aparılmalıdır.

Inhaltsverzeichnis Table of contents	Table de matieres Indice	Inhoud Indice
AD DABPZ / FKA3-2	8718531023	5
AD DABSSB / FKA9-2	8718531024	6
AD DABWB / FKA4-2	8718531025	7
AD ESS / FKA	7735600576	8
AD ESS / FKA6-2	8718531018	9
AD ESW	8718532808	10
AD GSS / FKA	7735600575	11
AD GSW	8718532807	12
AD SLPPZS / FKA15-2	8718531028	13
AD SLPSSS / FKA16-2	8718531029	14
AD SLPWPS / FKA17-2	8718531030	15
AD ZSAES / FKA12-2	8718531027	16
AD ZSAGS / FKA11-2	8718531026	17
FD BWS / FKF7-2	8718531035	18
FD ESS / FKF4-2	8718531032	19
FD ESW	8718532810	20
FD GSS / FKF3-2	8718531031	21
FD GSW	8718532809	22
FD ZSS / FKF8-2	8718531036	23
FD ZSW / FKF9-2	8718531037	24
FKA 5-2	8718531017	25
ID EKWS	8718532840	26
ID ESSH	8718532917	27
ID ESSS	8718532914	28
ID ESSZ	8718532911	29
ID ESWH	8718532845	30
ID ESWS	8718532842	31
ID ESWZ	8718532839	32
ID GSSH	8718532916	33
ID GSSS	8718532913	34
ID GSSZ	8718532910	35
ID GSWH	8718532844	36
ID GSWS	8718532841	37
ID GSWZ	8718532837	38
ID GSWZ	8718532838	39
ID HES / FK127-2	8718531004	40
ID HEW	8718532843	41
ID PZES / FK13-2	8718530980	42
ID SSES / FK115-2	8718530992	43

Ersatzteilliste
 Spare parts list
 Liste des pièces de rechange
 Lista parti di ricambio
 Lista de repuestos
 Catálogo de peças de substituição

AD DABPZ / FKA3-2 - 8718531023

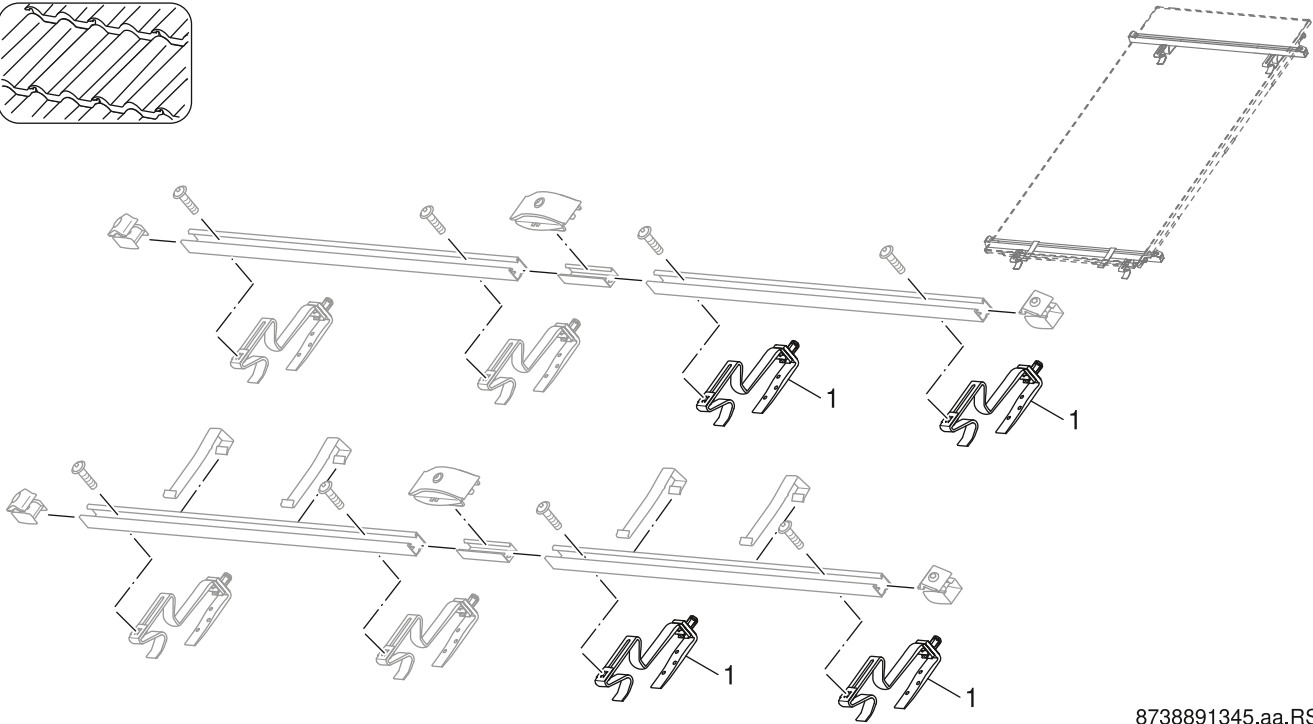
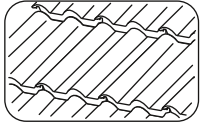

8738891345.aa.RS

	Bestell-Nr.	Bezeichnung	Description	Dénomination	Descrizioni	Descripción	Designação
1	8 718 531 307 0	Dachhaken	Roof hook	crochets de toit	ganci per tetto	ganchos	ganchos do telhado

Ersatzteilliste
 Spare parts list
 Liste des pièces de rechange
 Lista parti di ricambio
 Lista de repuestos
 Catálogo de peças de substituição

AD DABSSB / FKA9-2 - 8718531024

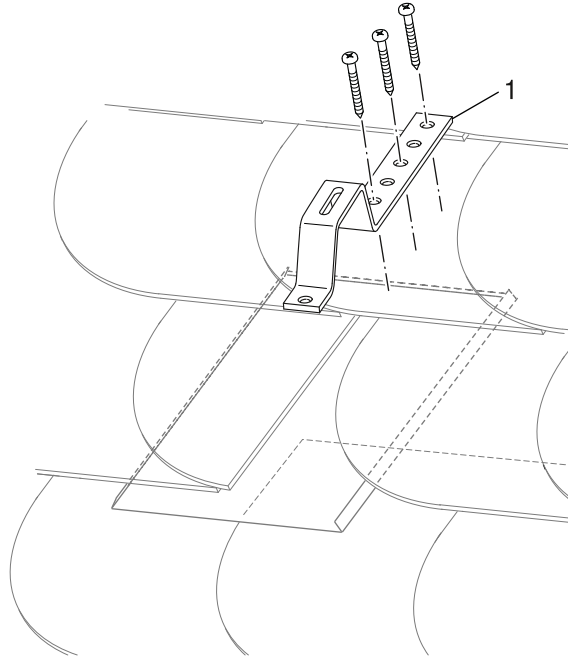
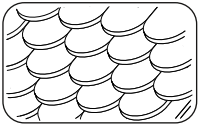

8738891382.aa.RS

	Bestell-Nr.	Bezeichnung	Description	Dénomination	Descrizioni	Descripción	Designação
1	8 718 531 643 0	Montage-Set SSB	Installation set SSB	kit de montage	set di montaggio	juego de montaje	conjunto de montagem

Ersatzteilliste
 Spare parts list
 Liste des pièces de rechange
 Lista parti di ricambio
 Lista de repuestos
 Catálogo de peças de substituição

AD DABWB / FKA4-2 - 8718531025

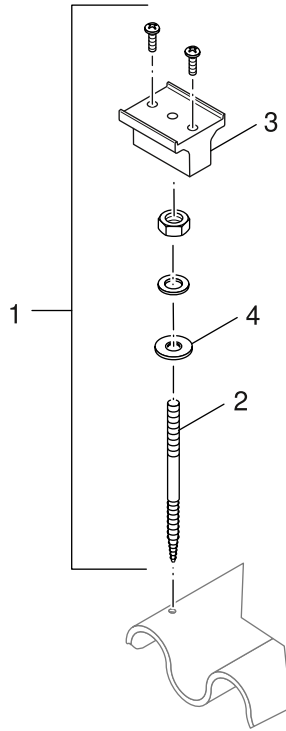
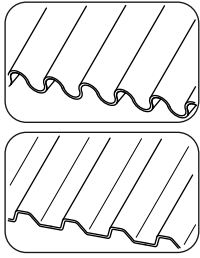

8738891383.aa.RS

	Bestell-Nr.	Bezeichnung	Description	Dénomination	Descrizioni	Descripción	Designação
1	8 748 511 021 0	Halterungs-Set (Welleternit)	Bracket kit (corrugated Eternit)	Jeu de montage (Eternit ondulée)	Set staffe montaggio (Eternit ondulato)	Conjunto de montaje (Corrugado Eternit)	Conjunto de suporte (Eternit ondulado)
2	8 748 511 024 0	Schraube M12x180 A4-70	Screw M12x180 A4-70	Screw M12x180 A4-70	Vite M12x180 A4-70	cerrojo	Parafuso M12x180 A4-70
3	8 718 531 644 0	Träger	Fixing bracket	Plaque de jonction	Supporto	Soporte	Fixing bracket
4	8 748 511 023 0	Dichtung (Welleternit, Bitumen) (4x)	Seal (corrugated Eternit, bitumen) (4x)	Joint (Eternit ondulée, Bitumes) (4x)	Guarnizione(Eternit ondulato, Bitume)(4x)	Junta (Corrugado Eternit, Bitumen) (4x)	Vedação (Eternit ondulado, Betume) (4x)

Ersatzteilliste
 Spare parts list
 Liste des pièces de rechange
 Lista parti di ricambio
 Lista de repuestos
 Catálogo de peças de substituição

AD ESS / FKA - 7735600576

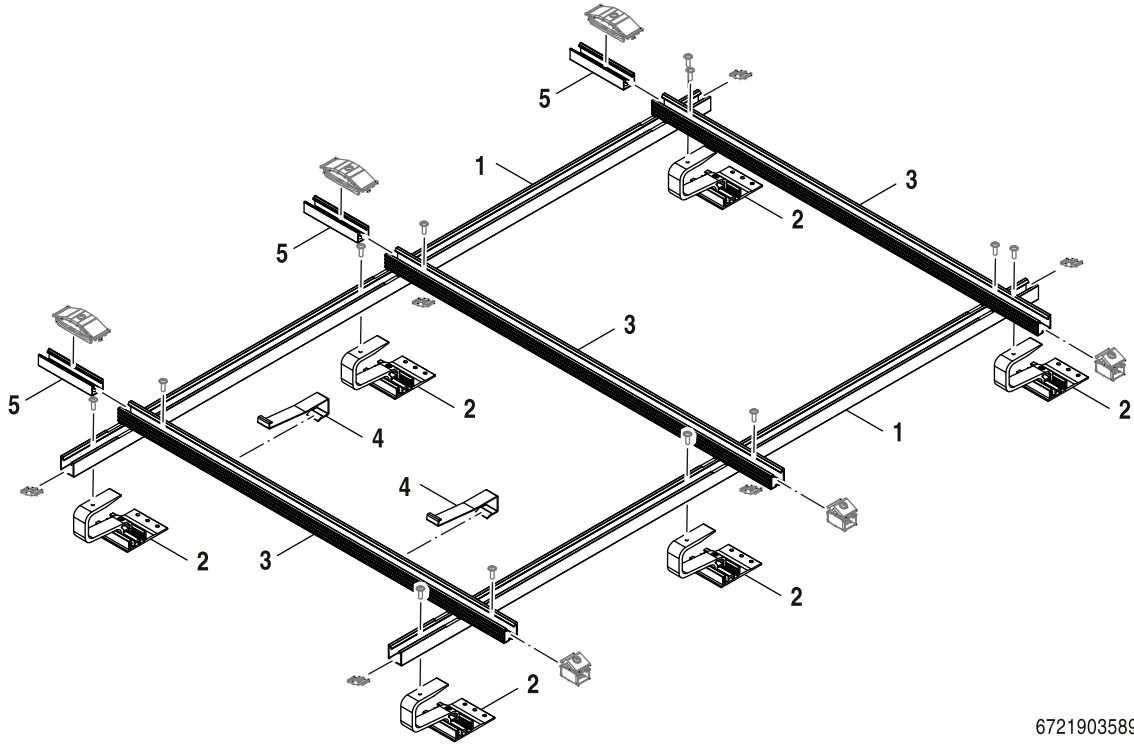

6721903589.aa.RO

	Bestell-Nr.	Bezeichnung	Description	Dénomination	Descrizioni	Descripción	Designação
1	8 718 531 358 0	Schiene 1940 mm	Rail 1940 mm	rail 1940 mm	Binario	rail	Rail 1940 mm
2	7 735 600 105	Sparrenanker 4er Set VKA	Roof anchor set VKA	Ancrage comble 4 pieces	Set fissaggio 4 pezzi		
2	7 735 600 175	Sparrenanker 2er Set	Roof anchor twin set	Set de fixation poutre 2 pieces	Set fissaggio 2 pezzi		
3	8 718 531 137 0	Schiene 1175 mm Comfort	Rail 1175 mm comfort	rail 1175 mm comfort	Binario 1175 mm comfort	carril 1175 mm comfort	calha 1175 mm comfort
4	8 748 511 005 0	Abrutschsicherung everp	Slipping safety	Glissière de sécurité	sicurezza	Deslizamiento de seguridad	Clip anti-deslizamento
5	8 718 531 224 0	Steckverbinder	Connector bar	Raccord rail profile	Giunto ad innesto Guida profilata	Pieza Unión Tornillos sujeción Estructu	Barra de ligação

Ersatzteilliste
 Spare parts list
 Liste des pièces de rechange
 Lista parti di ricambio
 Lista de repuestos
 Catálogo de peças de substituição

AD ESS / FKA6-2 - 8718531018

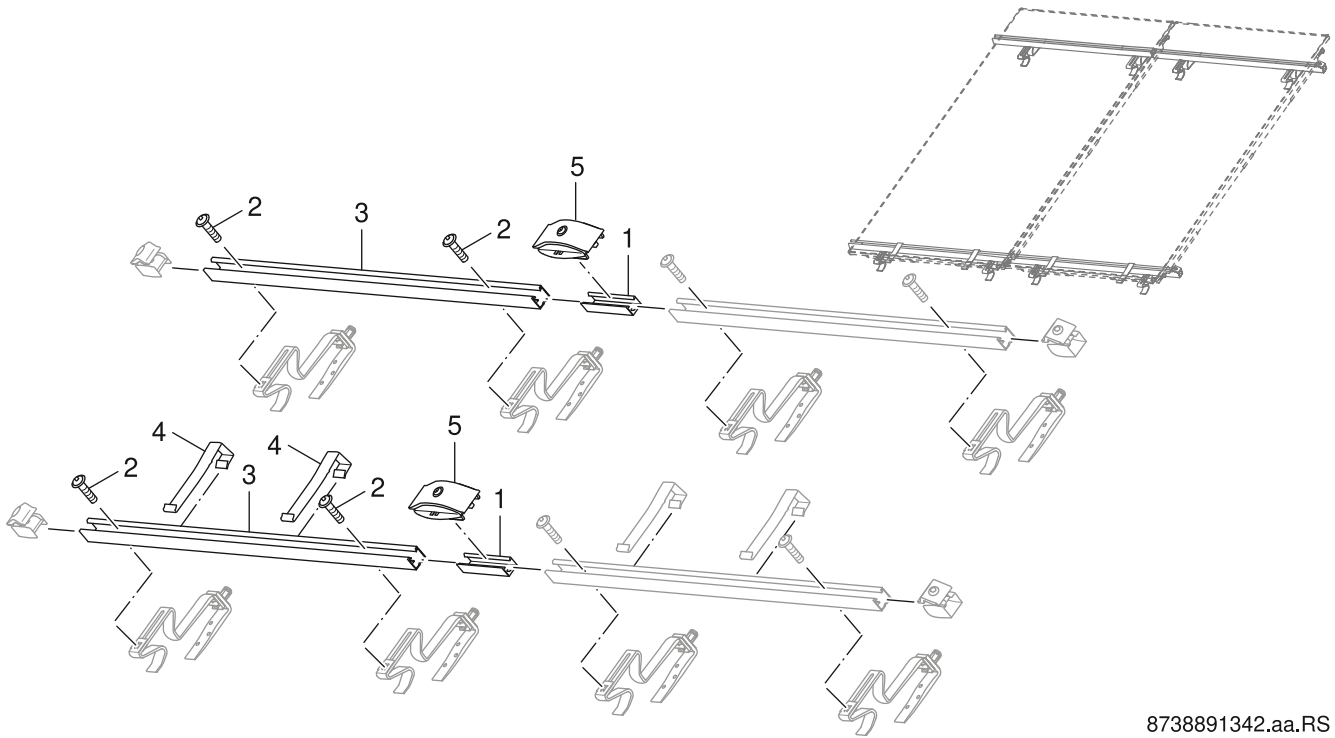

8738891342.aa.RS

	Bestell-Nr.	Bezeichnung	Description	Dénomination	Descrizioni	Descripción	Designação
1	8 718 531 224 0	Steckverbinder	Connector bar	Raccord rail profile	Giunto ad innesto Guida profilata	Pieza Unión Tornillos sujeción Estructu	Barra de ligação
2	8 718 531 370 0	Schrauben-Set (4x)	Screw Set (4x)	Vis (4x)	Vite di (4x)	Tornillo de ajuste (4x)	Schew Set (4x)
3	8 718 531 137 0	Schiene 1175 mm Comfort	Rail 1175 mm comfort	rail 1175 mm comfort	Binario 1175 mm comfort	carril 1175 mm comfort	calha 1175 mm comfort
4	8 748 511 005 0	Abrutschsicherung everp	Slipping safety	Glissière de sécurité	sicurezza	Deslizamiento de seguridad	Clip anti-deslizamento
5	8 718 531 261 0	Kollektorspanner doppelt	Collector clamp double	clip	Graffa	Pieza conexión estructura	grampo

Ersatzteilliste
 Spare parts list
 Liste des pièces de rechange
 Lista parti di ricambio
 Lista de repuestos
 Catálogo de peças de substituição

AD ESW - 8718532808

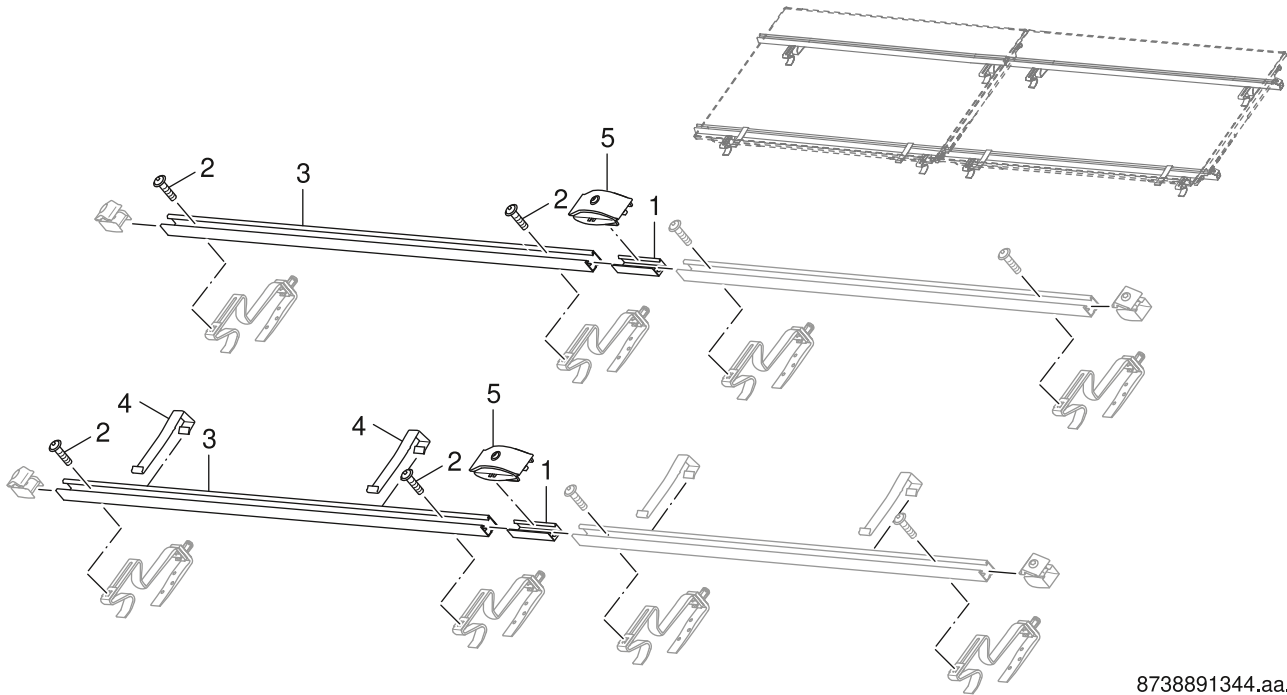

8738891344.aa.RS

	Bestell-Nr.	Bezeichnung	Description	Dénomination	Descrizioni	Descripción	Designação
1	8 718 531 224 0	Steckverbinder	Connector bar	Raccord rail profile	Giunto ad innesto Guida profilata	Pieza Unión Tornillos sujeción Estructu	Barra de ligação
2	8 718 531 370 0	Schrauben-Set (4x)	Screw Set (4x)	Vis (4x)	Vite di (4x)	Tornillo de ajuste (4x)	Schew Set (4x)
3	8 718 533 085 0	Schiene waagrecht Top	Rail horizontal top	Rail horizontal top	Rotaia orizzontale top	Rail horizontal top	Rail horizontal top
4	8 748 511 005 0	Abrutschsicherung everp	Slipping safety	Glissière de sécurité	sicurezza	Deslizamiento de seguridad	Clip anti-deslizamento
5	8 718 531 261 0	Kollektorspanner doppelt	Collector clamp double	clip	Graffa	Pieza conexión estructura	grampo

Ersatzteilliste
 Spare parts list
 Liste des pièces de rechange
 Lista parti di ricambio
 Lista de repuestos
 Catálogo de peças de substituição

AD GSS / FKA - 7735600575

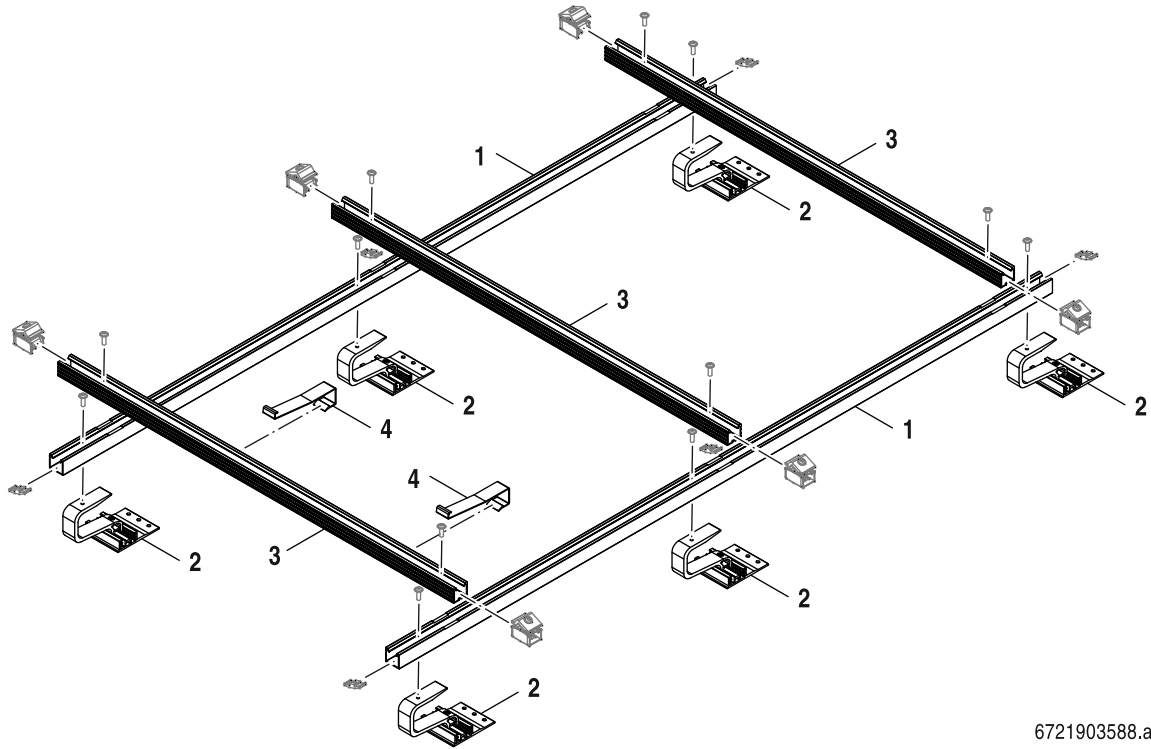

6721903588.aa.RO

	Bestell-Nr.	Bezeichnung	Description	Dénomination	Descrizioni	Descripción	Designação
1	8 718 531 358 0	Schiene 1940 mm	Rail 1940 mm	rail 1940 mm	Binario	rail	Rail 1940 mm
2	7 735 600 105	Sparrenanker 4er Set VKA	Roof anchor set VKA	Ancrage comble 4 pieces	Set fissaggio 4 pezzi		
2	7 735 600 175	Sparrenanker 2er Set	Roof anchor twin set	Set de fixation poutre 2 pieces	Set fissaggio 2 pezzi		
3	8 718 531 137 0	Schiene 1175 mm Comfort	Rail 1175 mm comfort	rail 1175 mm comfort	Binario 1175 mm comfort	carril 1175 mm comfort	calha 1175 mm comfort
4	8 748 511 005 0	Abrutschsicherung everp	Slipping safety	Glissière de sécurité	sicurezza	Deslizamiento de seguridad	Clip anti-deslizamento

Ersatzteilliste
 Spare parts list
 Liste des pièces de rechange
 Lista parti di ricambio
 Lista de repuestos
 Catálogo de peças de substituição

AD GSW - 8718532807

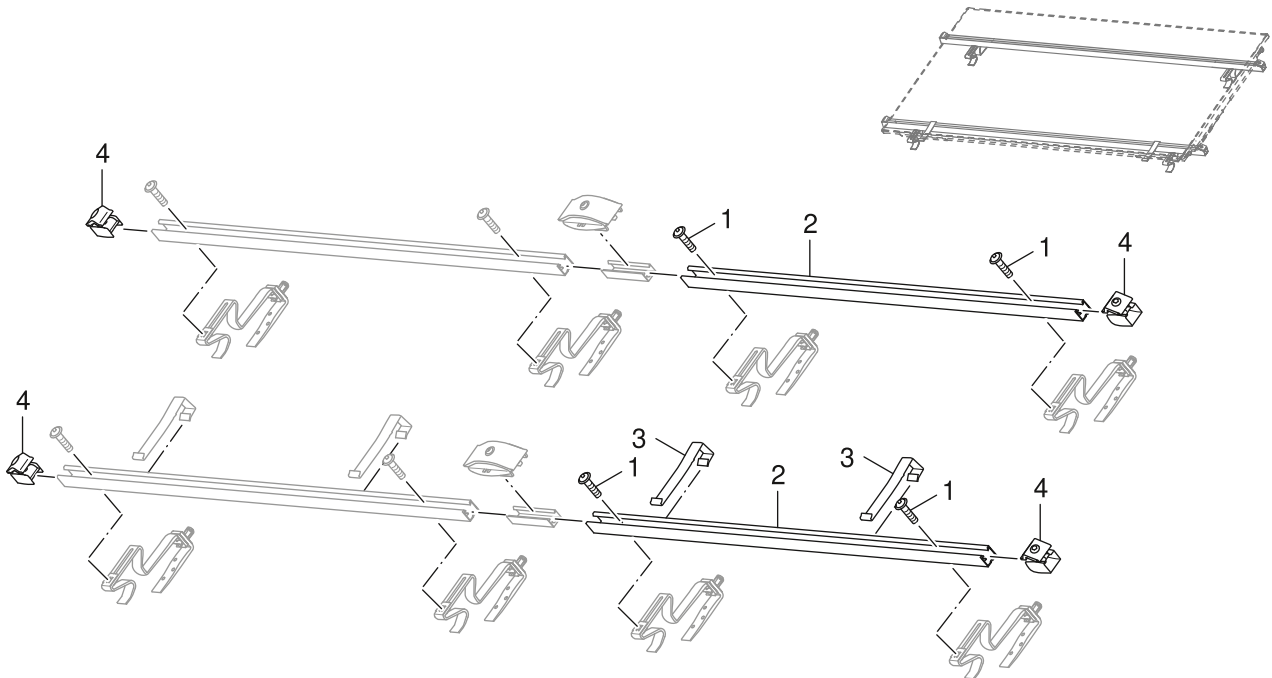

8738891343.aa.RS

	Bestell-Nr.	Bezeichnung	Description	Dénomination	Descrizioni	Descripción	Designação
1	8 718 531 370 0	Schrauben-Set (4x)	Screw Set (4x)	Vis (4x)	Vite di (4x)	Tornillo de ajuste (4x)	Schew Set (4x)
2	8 718 533 085 0	Schiene waagerecht Top	Rail horizontal top	Rail horizontal top	Rotaia orizzontale top	Rail horizontal top	Rail horizontal top
3	8 748 511 005 0	Abrutschsicherung everp	Slipping safety	Glissière de sécurité	sicurezza	Deslizamiento de seguridad	Clip anti-deslizamento
4	8 718 531 143 0	Kollektorspanner einfach	Collector clamp single	clip	Graffa	Pieza terminación estructura	grampo

Ersatzteilliste
 Spare parts list
 Liste des pièces de rechange
 Lista parti di ricambio
 Lista de repuestos
 Catálogo de peças de substituição

AD SLPPZS / FKA15-2 - 8718531028

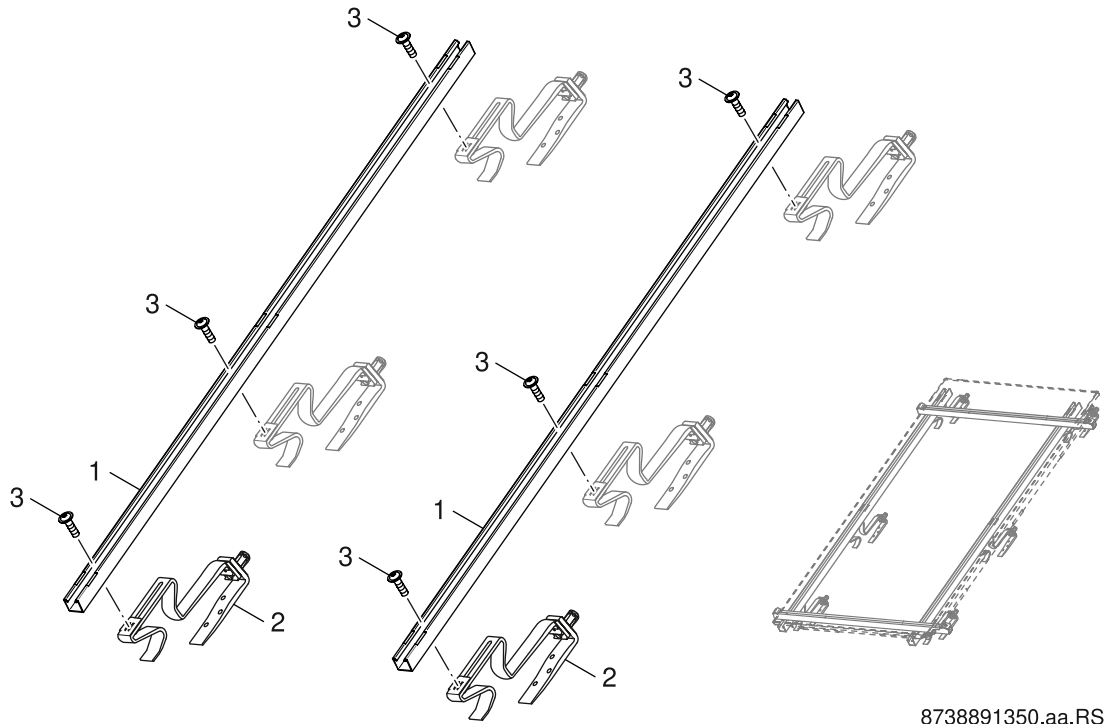
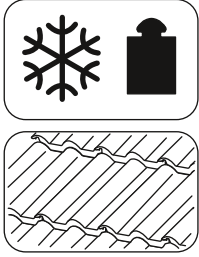

8738891350.aa.RS

	Bestell-Nr.	Bezeichnung	Description	Dénomination	Descrizioni	Descripción	Designação
1	8 718 531 358 0	Schiene 1940 mm	Rail 1940 mm	rail 1940 mm	Binario	rail	Rail 1940 mm
2	8 718 531 307 0	Dachhaken	Roof hook	crochets de toit	ganci per tetto	ganchos	ganchos do telhado
3	8 718 531 370 0	Schrauben-Set (4x)	Screw Set (4x)	Vis (4x)	Vite di (4x)	Tornillo de ajuste (4x)	Schew Set (4x)

Ersatzteilliste
 Spare parts list
 Liste des pièces de rechange
 Lista parti di ricambio
 Lista de repuestos
 Catálogo de peças de substituição

AD SLPSSS / FKA16-2 - 8718531029

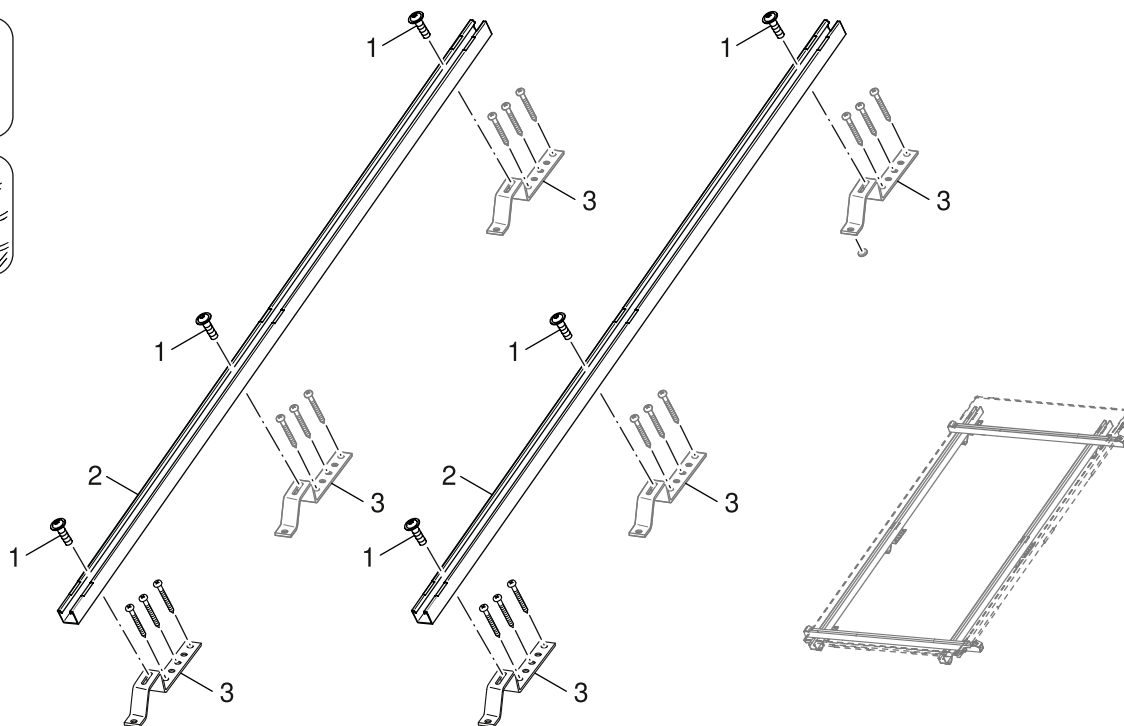
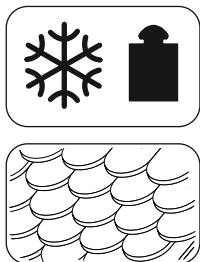

8738891351.aa.RS

	Bestell-Nr.	Bezeichnung	Description	Dénomination	Descrizioni	Descripción	Designação
1	8 718 531 370 0	Schrauben-Set (4x)	Screw Set (4x)	Vis (4x)	Vite di (4x)	Tornillo de ajuste (4x)	Schew Set (4x)
2	8 718 531 358 0	Schiene 1940 mm	Rail 1940 mm	rail 1940 mm	Binario	rail	Rail 1940 mm
3	8 718 531 643 0	Montage-Set SSB	Installation set SSB	kit de montage	set di montaggio	juego de montaje	conjunto de montagem

Ersatzteilliste
 Spare parts list
 Liste des pièces de rechange
 Lista parti di ricambio
 Lista de repuestos
 Catálogo de peças de substituição

AD SLPWPS / FKA17-2 - 8718531030

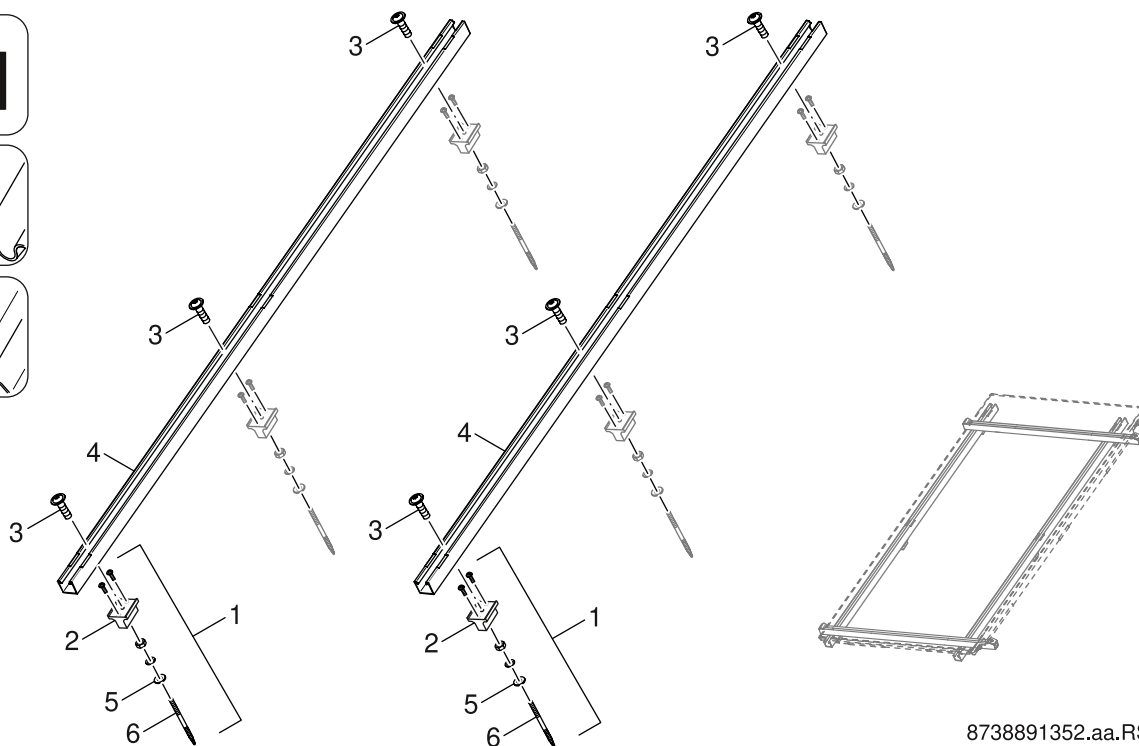
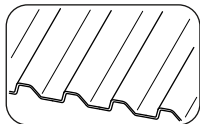
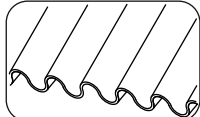

8738891352.aa.RS

	Bestell-Nr.	Bezeichnung	Description	Dénomination	Descrizioni	Descripción	Designação
1	8 748 511 021 0	Halterungs-Set (Welleternit)	Bracket kit (corrugated Eternit)	Jeu de montage (Eternit ondulée)	Set staffe montaggio (Eternit ondulato)	Conjunto de montaje (Corrugado Eternit)	Conjunto de suporte (Eternit ondulado)
2	8 718 531 644 0	Träger	Fixing bracket	Plaque de jonction	Supporto	Soporte	Fixing bracket
3	8 718 531 370 0	Schrauben-Set (4x)	Screw Set (4x)	Vis (4x)	Vite di (4x)	Tornillo de ajuste (4x)	Schew Set (4x)
4	8 718 531 358 0	Schiene 1940 mm	Rail 1940 mm	rail 1940 mm	Binario	rail	Rail 1940 mm
5	8 748 511 023 0	Dichtung (Welleternit, Bitumen) (4x)	Seal (corrugated Eternit, bitumen) (4x)	Joint (Eternit ondulée, Bitumes) (4x)	Guarnizione(Eternit ondulato, Bitume)(4x)	Junta (Corrugado Eternit, Bitumen) (4x)	Vedação (Eternit ondulado, Betume) (4x)
6	8 748 511 024 0	Schraube M12x180 A4-70	Screw M12x180 A4-70	Screw M12x180 A4-70	Vite M12x180 A4-70	cerrojo	Parafuso M12x180 A4-70

Ersatzteilliste
 Spare parts list
 Liste des pièces de rechange
 Lista parti di ricambio
 Lista de repuestos
 Catálogo de peças de substituição

AD ZSAES / FKA12-2 - 8718531027

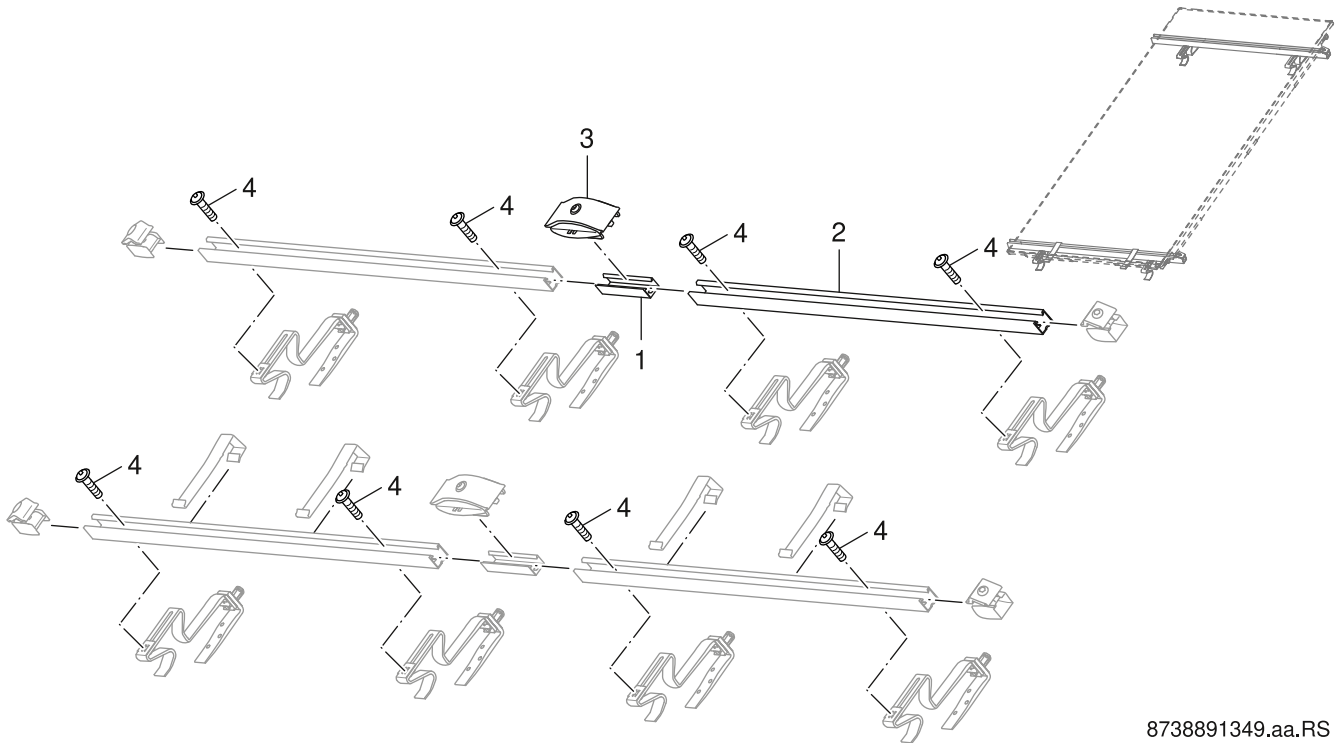

8738891349.aa.RS

	Bestell-Nr.	Bezeichnung	Description	Dénomination	Descrizioni	Descripción	Designação
1	8 718 531 224 0	Steckverbinder	Connector bar	Raccord rail profile	Giunto ad innesto Guida profilata	Pieza Unión Tornillos sujeción Estructu	Barra de ligação
2	8 718 531 137 0	Schiene 1175 mm Comfort	Rail 1175 mm comfort	rail 1175 mm comfort	Binario 1175 mm comfort	carril 1175 mm comfort	calha 1175 mm comfort
3	8 718 531 261 0	Kollektorspanner doppelt	Collector clamp double	clip	Graffa	Pieza conexión estructura	grampo
4	8 718 531 370 0	Schrauben-Set (4x)	Screw Set (4x)	Vis (4x)	Vite di (4x)	Tornillo de ajuste (4x)	Schew Set (4x)

Ersatzteilliste
 Spare parts list
 Liste des pièces de rechange
 Lista parti di ricambio
 Lista de repuestos
 Catálogo de peças de substituição

AD ZSAGS / FKA11-2 - 8718531026

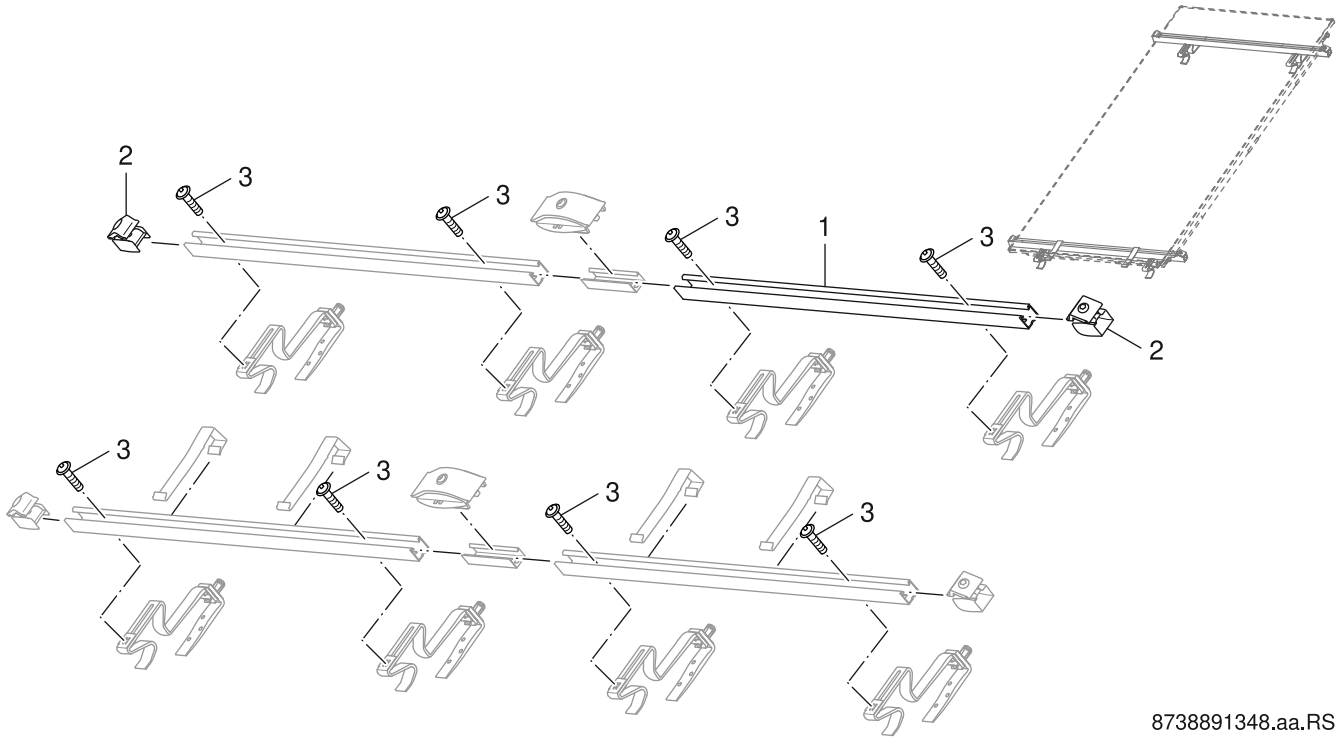

8738891348.aa.RS

	Bestell-Nr.	Bezeichnung	Description	Dénomination	Descrizioni	Descripción	Designação
1	8 718 531 137 0	Schiene 1175 mm Comfort	Rail 1175 mm comfort	rail 1175 mm comfort	Binario 1175 mm comfort	carril 1175 mm comfort	calha 1175 mm comfort
2	8 718 531 143 0	Kollektorspanner einfach	Collector clamp single	clip	Graffa	Pieza terminación estructura	grampo
3	8 718 531 370 0	Schrauben-Set (4x)	Screw Set (4x)	Vis (4x)	Vite di (4x)	Tornillo de ajuste (4x)	Schew Set (4x)

Ersatzteilliste
 Spare parts list
 Liste des pièces de rechange
 Lista parti di ricambio
 Lista de repuestos
 Catálogo de peças de substituição

FD BWS / FKF7-2 - 8718531035

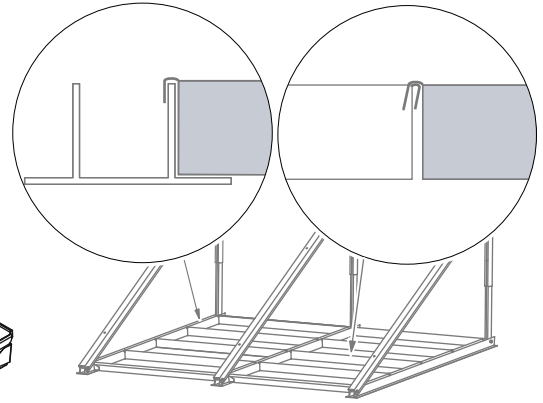
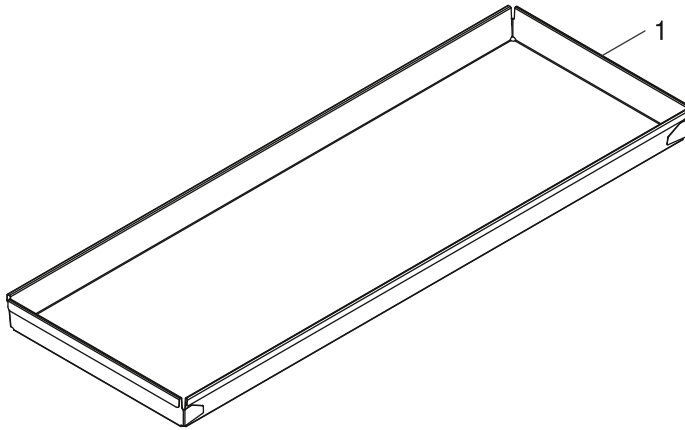

8738891357.aa.RS

	Bestell-Nr.	Bezeichnung	Description	Dénomination	Descrizioni	Descripción	Designação
1	8 748 511 074 0	Wanne	Loading tank	Récepteur eau	SUPPORTO	Bandeja de carga	Bandeja de carga

Ersatzteilliste
Spare parts list
Liste des pièces de rechange
Lista parti di ricambio
Lista de repuestos
Catálogo de peças de substituição

FD ESS / FKF4-2 - 8718531032

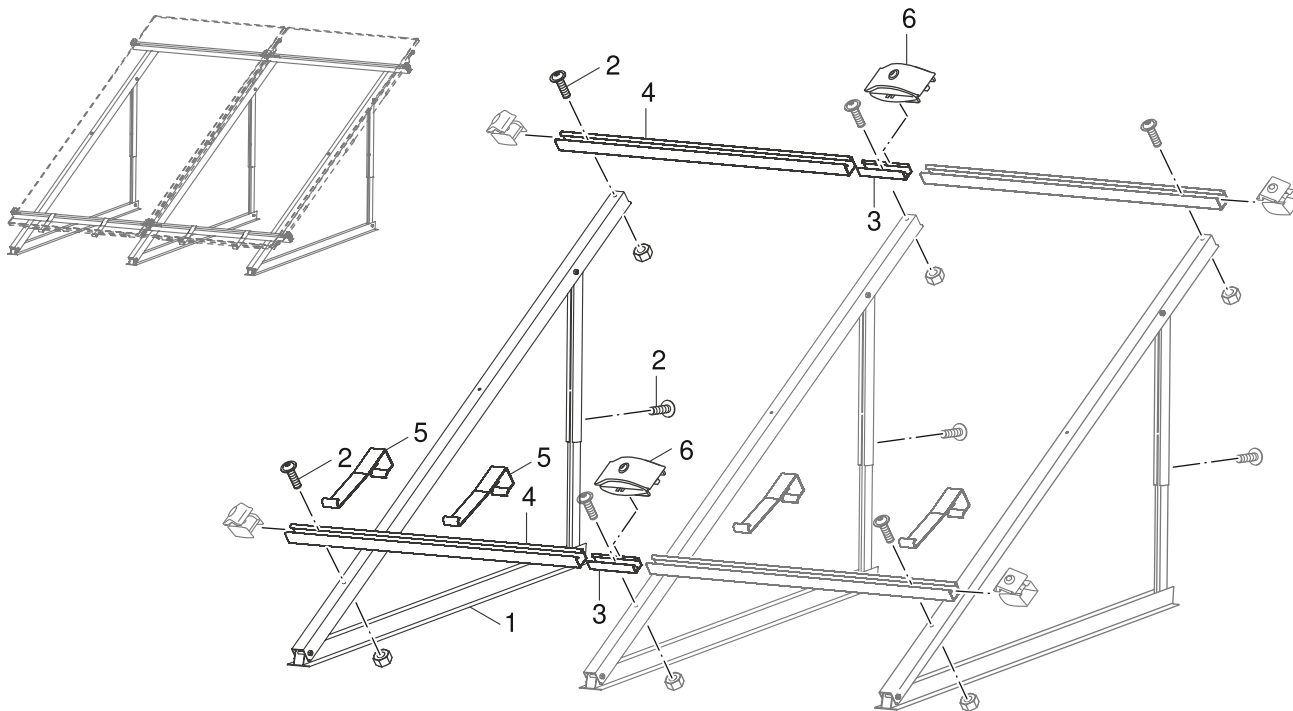

8738891354.aa.RS

	Bestell-Nr.	Bezeichnung	Description	Dénomination	Descrizioni	Descripción	Designação
1	8 718 531 036	Flachd Zusatzstütze senk Comfort/Top	Aux.-rail flat roof support vert com./to	Eq.renf.sup.vert.TT FKC	Supporto aggiuntivo su tetto piano vert.	Perfil FKF 8-2	Perfil sup.adic.vert. telhd. pl. com./to
2	8 718 220 764 0	Befestigungsset (5x)	mounting parts (5x)	Jeu de pièces de fixation (5x)	Set di fissaggio (5x)	Elementos de fijación Termosifón (5x)	Peças de fixação (5x)
3	8 718 531 224 0	Steckverbinder	Connector bar	Raccord rail profile	Giunto ad innesto Guida profilata	Pieza Unión Tornillos sujección Estructu	Barra de ligação
4	8 718 531 137 0	Schiene 1175 mm Comfort	Rail 1175 mm comfort	rail 1175 mm comfort	Binario 1175 mm comfort	carril 1175 mm comfort	calha 1175 mm comfort
5	8 748 511 005 0	Abrutschsicherung everp	Slipping safety	Glissière de sécurité	sicurezza	Deslizamiento de seguridad	Clip anti-deslizamento
6	8 718 531 261 0	Kollektorspanner doppelt	Collector clamp double	clip	Graffa	Pieza conexión estructura	grampo

Ersatzteilliste
 Spare parts list
 Liste des pièces de rechange
 Lista parti di ricambio
 Lista de repuestos
 Catálogo de peças de substituição

FD ESW - 8718532810

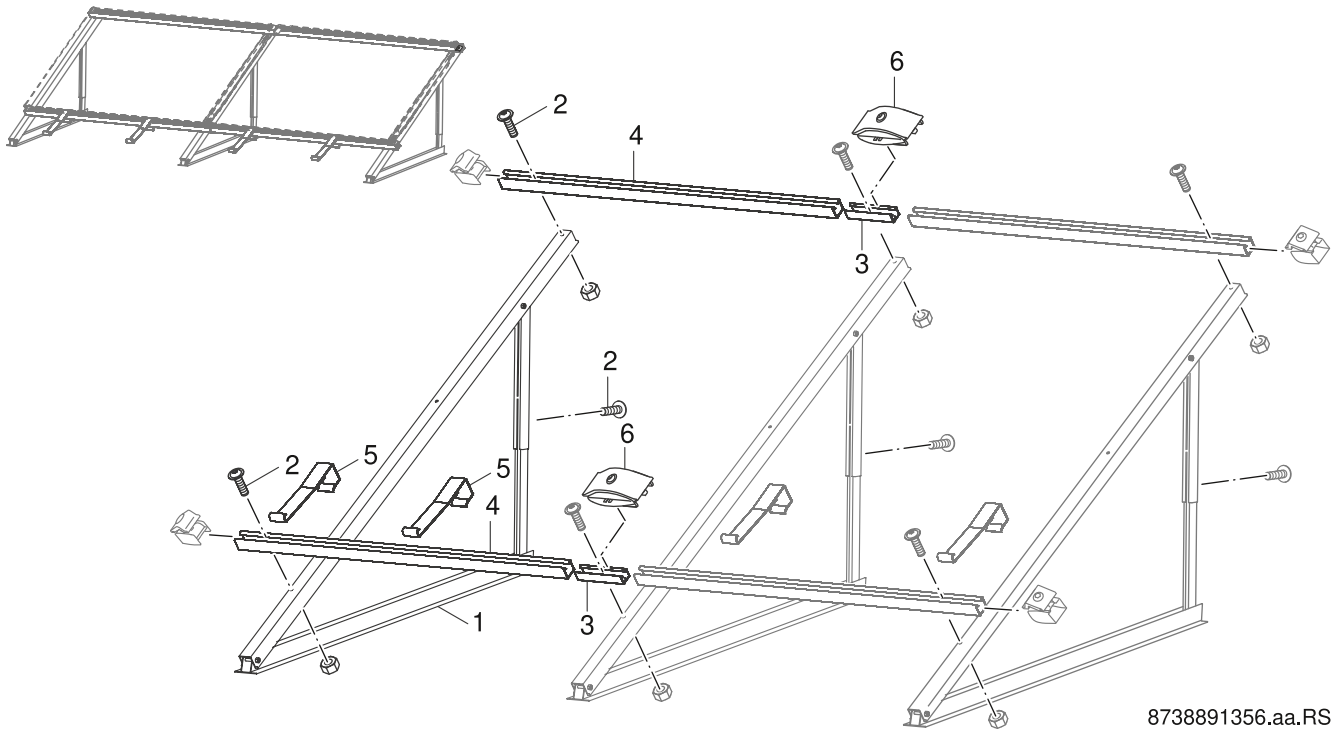

8738891356.aa.RS

	Bestell-Nr.	Bezeichnung	Description	Dénomination	Descrizioni	Descripción	Designação
1	8 718 531 037	Flachd Zusatzstütze waag Comfort/Top	Aux.-rail flat roof support horiz com./t	Eq.renf.sup.hor.TT FKC	Supporto aggiuntivo su tetto piano orriz	FKF 9 - 2T	Perfil sup.adic.hor. telhd. pl. com./top
2	8 718 220 764 0	Befestigungsset (5x)	mounting parts (5x)	Jeu de pièces de fixation (5x)	Set di fissaggio (5x)	Elementos de fijación Termosifón (5x)	Peças de fixação (5x)
3	8 718 531 224 0	Steckverbinder	Connector bar	Raccord rail profile	Giunto ad innesto Guida profilata	Pieza Unión Tornillos sujección Estructu	Barra de ligação
4	8 718 533 085 0	Schiene waagrecht Top	Rail horizontal top	Rail horizontal top	Rotaia orizzontale top	Rail horizontal top	Rail horizontal top
5	8 748 511 005 0	Abrutschsicherung everp	Slipping safety	Glissière de sécurité	sicurezza	Deslizamiento de seguridad	Clip anti-deslizamento
6	8 718 531 261 0	Kollektorspanner doppelt	Collector clamp double	clip	Graffa	Pieza conexión estructura	grampo

Ersatzteilliste
 Spare parts list
 Liste des pièces de rechange
 Lista parti di ricambio
 Lista de repuestos
 Catálogo de peças de substituição

FD GSS / FKF3-2 - 8718531031

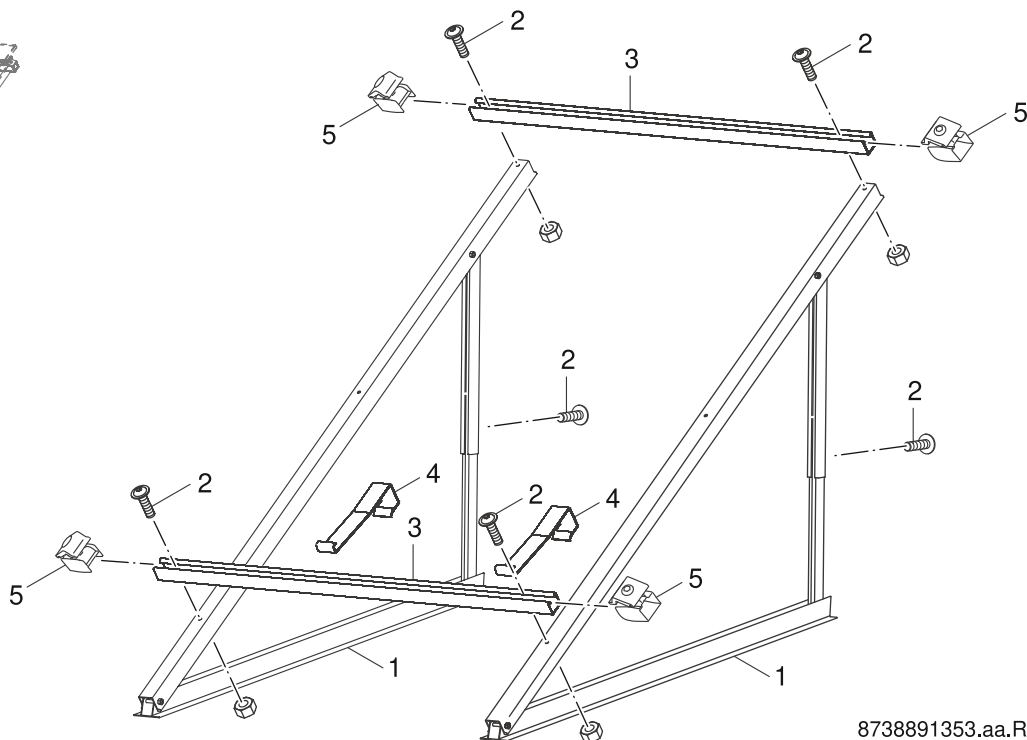
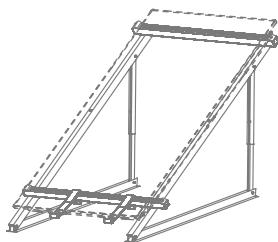

8738891353.aa.RS

	Bestell-Nr.	Bezeichnung	Description	Dénomination	Descrizioni	Descripción	Designação
1	8 718 531 036	Flachd Zusatzstütze senk Comfort/Top	Aux.-rail flat roof support vert com./to	Eq.renf.sup.vert.TT FKC	Supporto aggiuntivo su tetto piano vert.	Perfil FKF 8-2	Perfil sup.adic.vert. telhd. pl. com./to
2	8 718 220 764 0	Befestigungsset (5x)	mounting parts (5x)	Jeu de pièces de fixation (5x)	Set di fissaggio (5x)	Elementos de fijación Termosifón (5x)	Peças de fixação (5x)
3	8 718 531 137 0	Schiene 1175 mm Comfort	Rail 1175 mm comfort	rail 1175 mm comfort	Binario 1175 mm comfort	carril 1175 mm comfort	calha 1175 mm comfort
4	8 748 511 005 0	Abrutschsicherung everp	Slipping safety	Glissière de sécurité	sicurezza	Deslizamiento de seguridad	Clip anti-deslizamento
5	8 718 531 143 0	Kollektorspanner einfach	Collector clamp single	clip	Graffa	Pieza terminación estructura	grampo

Ersatzteilliste
Spare parts list
Liste des pièces de rechange
Lista parti di ricambio
Lista de repuestos
Catálogo de peças de substituição

FD GSW - 8718532809

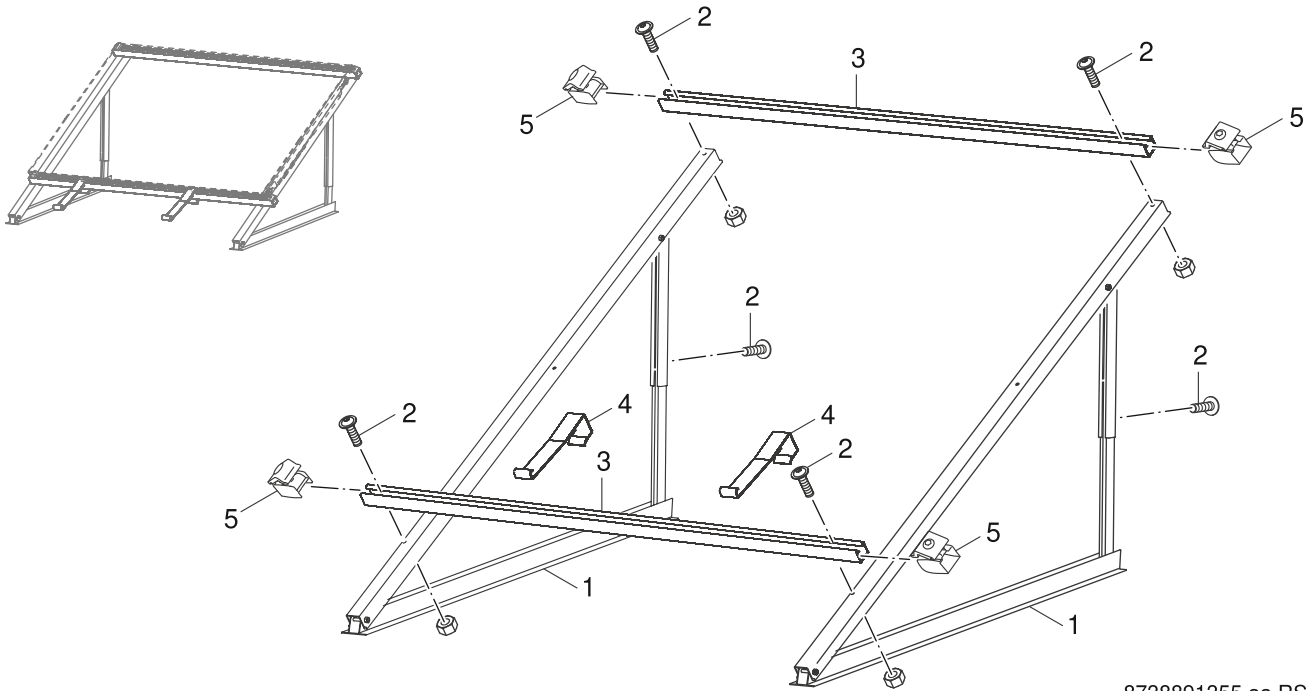

8738891355.aa.RS

	Bestell-Nr.	Bezeichnung	Description	Dénomination	Descrizioni	Descripción	Designação
1	8 718 531 037	Flachd Zusatzstütze waag Comfort/Top	Aux.-rail flat roof support horiz com./t	Eq.renf.sup.hor.TT FKC	Supporto aggiuntivo su tetto piano orriz	FKF 9 - 2T	Perfil sup.adic.hor. telhd. pl. com./top
2	8 718 220 764 0	Befestigungsset (5x)	mounting parts (5x)	Jeu de pièces de fixation (5x)	Set di fissaggio (5x)	Elementos de fijación Termosifón (5x)	Peças de fixação (5x)
3	8 718 533 085 0	Schiene waagrecht Top	Rail horizontal top	Rail horizontal top	Rotaia orizzontale top	Rail horizontal top	Rail horizontal top
4	8 748 511 005 0	Abrutschsicherung everp	Slipping safety	Glissière de sécurité	sicurezza	Deslizamiento de seguridad	Clip anti-deslizamento
5	8 718 531 143 0	Kollektorspanner einfach	Collector clamp single	clip	Graffa	Pieza terminación estructura	grampo

Ersatzteilliste
 Spare parts list
 Liste des pièces de rechange
 Lista parti di ricambio
 Lista de repuestos
 Catálogo de peças de substituição

FD ZSS / FKF8-2 - 8718531036

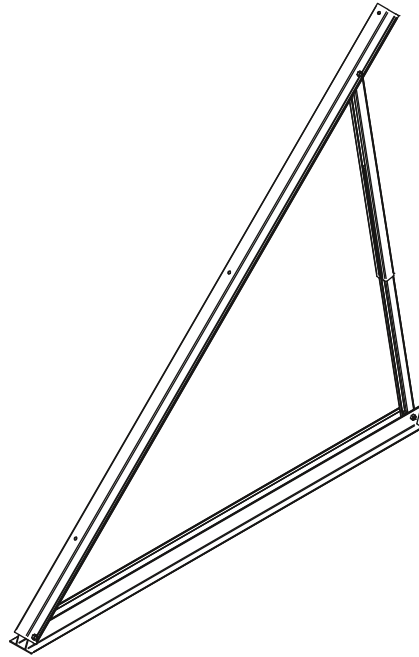

873889158.aa.RS

Bestell-Nr.	Bezeichnung	Description	Dénomination	Descrizioni	Descripción	Designação
8 710 000 000 0	Keine Ersatzteile verfügbar	No spare parts available	Aucune pièce détachée disponible	Non disponibili parti di ricambio	No disponible como repuesto	Não peças de substituição disponíveis

Ersatzteilliste
 Spare parts list
 Liste des pièces de rechange
 Lista parti di ricambio
 Lista de repuestos
 Catálogo de peças de substituição

FD ZSW / FKF9-2 - 8718531037

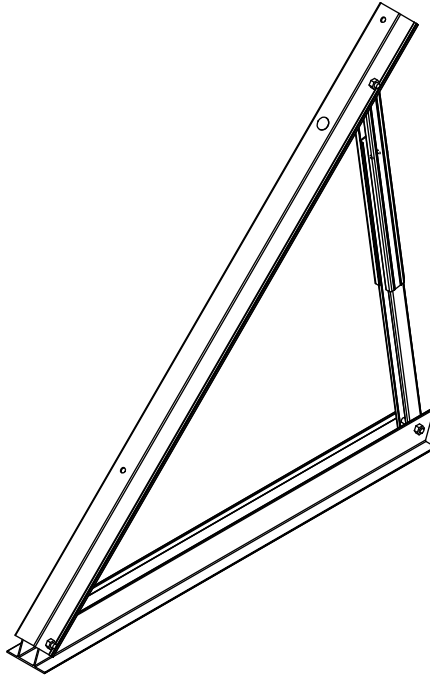

8738891359.ab.RS

Bestell-Nr.	Bezeichnung	Description	Dénomination	Descrizioni	Descripción	Designação
8 710 000 000 0	Keine Ersatzteile verfügbar	No spare parts available	Aucune pièce détachée disponible	Non disponibili parti di ricambio	No disponible como repuesto	Não peças de substituição disponíveis

Ersatzteilliste
 Spare parts list
 Liste des pièces de rechange
 Lista parti di ricambio
 Lista de repuestos
 Catálogo de peças de substituição

FKA 5-2 - 8718531017

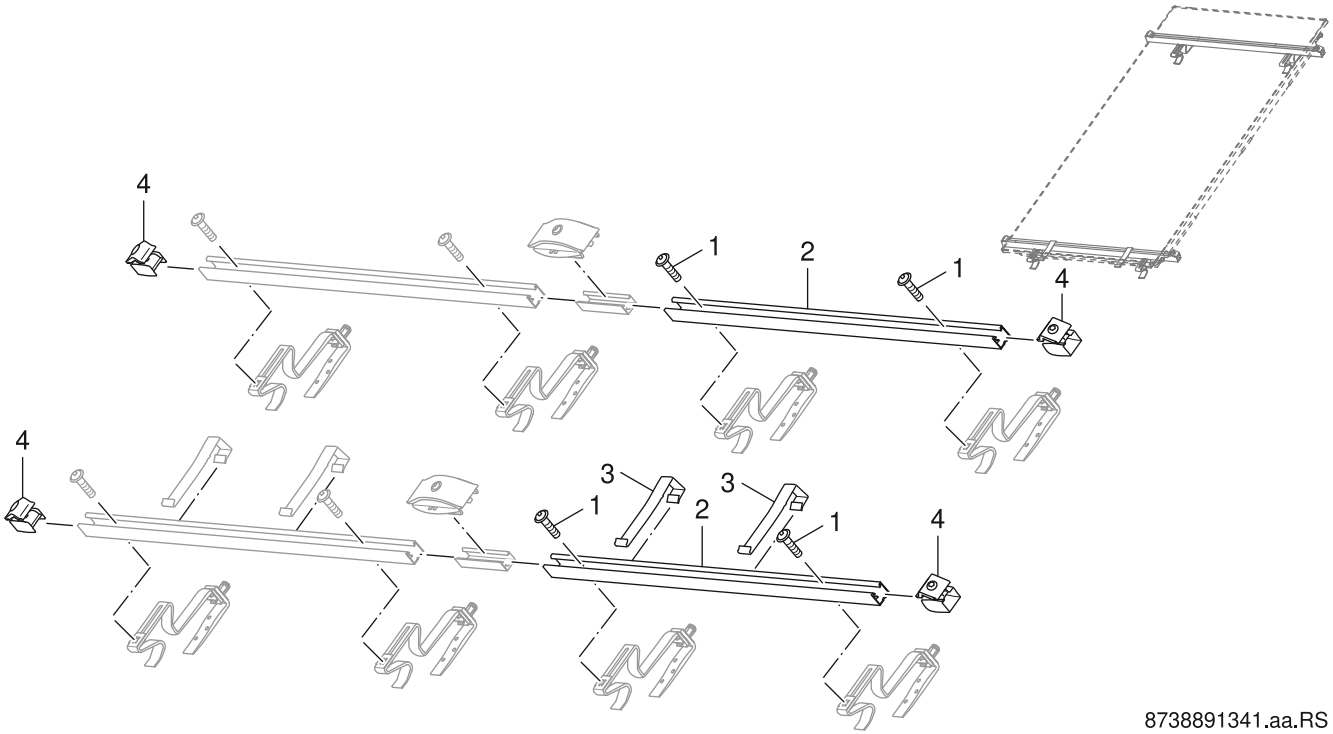

8738891341.aa.RS

	Bestell-Nr.	Bezeichnung	Description	Dénomination	Descrizioni	Descripción	Designação
1	8 718 531 370 0	Schrauben-Set (4x)	Screw Set (4x)	Vis (4x)	Vite di (4x)	Tornillo de ajuste (4x)	Schew Set (4x)
2	8 718 531 137 0	Schiene 1175 mm Comfort	Rail 1175 mm comfort	rail 1175 mm comfort	Binario 1175 mm comfort	carril 1175 mm comfort	calha 1175 mm comfort
3	8 748 511 005 0	Abrutschsicherung everp	Slipping safety	Glissière de sécurité	sicurezza	Deslizamiento de seguridad	Clip anti-deslizamento
4	8 718 531 143 0	Kollektorspanner einfach	Collector clamp single	clip	Graffa	Pieza terminación estructura	grampo

Ersatzteilliste
Spare parts list
Liste des pièces de rechange
Lista parti di ricambio
Lista de repuestos
Catálogo de peças de substituição

ID EKWS - 8718532840

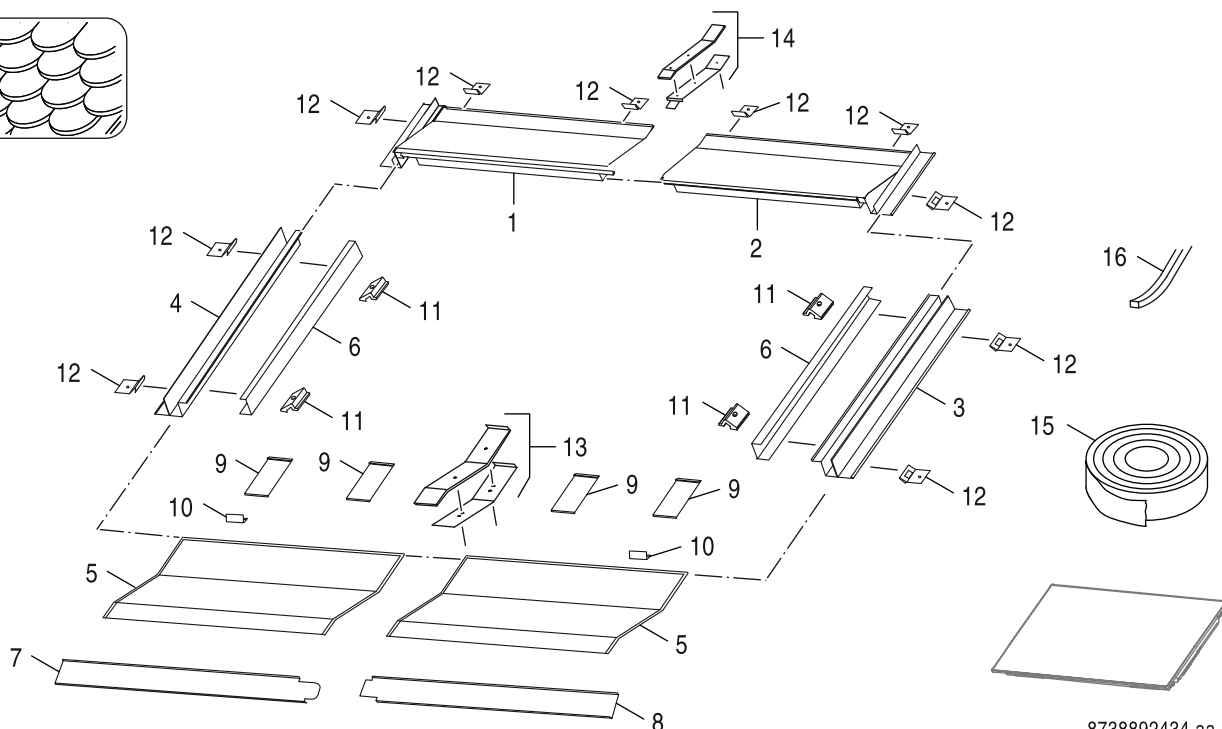
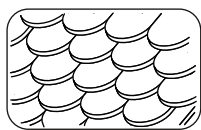

8738892434.aa.RO

	Bestell-Nr.	Bezeichnung	Description	Dénomination	Descrizioni	Descripción	Designação
1	8 718 533 316 0	Eindeckblech oben links	flashing panel top left	tôle de recouvrement haut gauche	lamiera di copertura sopra sinistra	chapa de recubrimiento arriba izquierda	flashing panel top left
2	8 718 533 317 0	Eindeckblech oben rechts	flashing panel top right	tôle de recouvrement haut droite	lamiera di copertura sopra destra	chapa de recubrimiento arriba derecha	flashing panel top right
3	8 718 531 728 0	Eindeckblech rechts oben	Cover right top	tôle de protection droite haut	Lamiera di protezione destra sopra	chapa de recubrimiento derecha arriba	Cover right top
4	8 718 531 729 0	Eindeckblech links oben	Cover left top	tôle de protection gauche haut	Lamiera di protezione sinistra sopra	chapa de recubrimiento izquierda arriba	Cover left top
5	8 718 533 328 0	Eindeckblech unten links/rechts	flashing panel bottom left/right	tôle de recouvrement bas gauche/droite	lamiera di copertura sotto sinistra/dest	chapa de recubrimiento debajo iz./ de.	flashing panel bottom left/right
6	8 718 531 749 0	Stützblech waagrecht	Sheet horizontal	tôle horizontal	Lamierino orizzontale	chapa horizontal	Sheet horizontal
7	8 718 533 336 0	Blende links	cover panel links	tôle de recouvrement links	pannello di copertura links	chapa de recubrimiento links	cover panel links
8	8 718 533 337 0	Blende rechts	cover panel rechts	tôle de recouvrement rechts	pannello di copertura rechts	chapa de recubrimiento rechts	cover panel rechts
9	8 718 531 771 0	Montagehalter	Support	matériel de montage	materiale di montaggio	material de montaje	Support
10	8 718 531 772 0	Abrutschsicherung	Support Slipping safty	Dispositif anti-glisement	scivolo	Tope	Support Slipping safty
11	8 718 531 773 0	Montagehalter seitlich	Support side	Support latéral	materiale di montaggio laterale	material de montaje lateral	Support side
12	8 748 511 055 0	Halter (6x)	support (6x)	PATTE FIXATION KIT MONT CAPTEUR (6x)	Supporto (6x)	Soporte de fijación (6x)	Suporte (6x)
13	8 718 531 770 0	Verbinder unten	Connector bottom	kit de raccordement bas	Set di collegamento sotto	set conector debajo	Connector bottom
14	8 718 533 342 0	Verbinder oben	connector set top	kit de raccordement haut	Set di collegamento sopra	set conector arriba	connector set top
15	8 718 223 903 0	Dichtschnur UEB Schiefer	Sealing UEB slate	Cordon d'étanchéité	Cordone ermetizzante	cordón junta	Sealing UEB slate
16	6 304 637 5	Dichtband Hannoband 10x10x6300 verp	Tape Hannoband 10x10x6300	Bande d'étanchéité p/tuiles creuses	Guarnizione Hannoband 10x10x6300	junta Hannoband 10x10x6300	vedação Hannoband 10x10x6300

Ersatzteilliste
Spare parts list
Liste des pièces de rechange
Lista parti di ricambio
Lista de repuestos
Catálogo de peças de substituição

ID ESSH - 8718532917

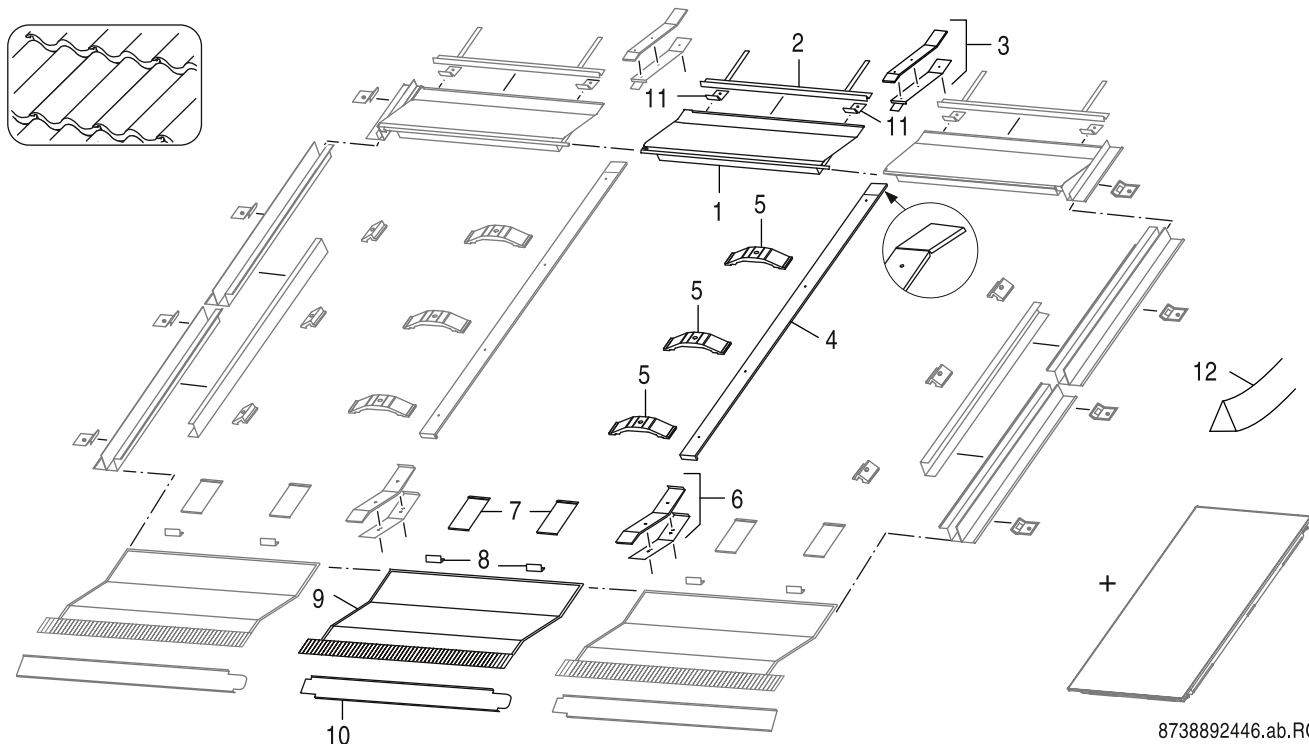

	Bestell-Nr.	Bezeichnung	Description	Dénomination	Descrizioni	Descripción	Designação
1	8 718 531 714 0	Eindeckblech oben mitte	Cover top middle	tôle de protection haut milieu	Lamiera di protezione sopra intermedio	chapa de recubrimiento arriba Mitad	Cover top middle
2	8 748 511 075 0	Schiene	Bar	Barre	Telaio	Respaldo	Caixilho
3	8 718 533 343 0	Verbinder oben	connector set top	kit de raccordement haut	Set di collegamento sopra	set conector arriba	connector set top
4	8 718 533 341 0	Mittelschiene	Cover middle	rail milieu	rotaia intermedio	Rail	Cover middle
5	8 718 531 774 0	Montagehalter	Support	Support de montage	materiale di montaggio	material de montaje	Support
6	8 718 531 765 0	Verbinder unten	Connector bottom	kit de raccordement bas	Set di collegamento sotto	set conector debajo	Connector bottom
7	8 718 531 771 0	Montagehalter	Support	matériel de montage	materiale di montaggio	material de montaje	Support
8	8 718 531 772 0	Abrutschsicherung	Support Slipping safty	Dispositif anti-glisement	scivolo	Tope	Support Slipping safty
9	8 718 531 736 0	Eindeckblech unten mitte	Cover bottom middle	tôle de protection bas milieu	Lamiera di protezione sotto intermedio	chapa de recubrimiento debajo Mitad	Cover bottom middle
10	8 718 531 752 0	Blende mitte	Cover Cover middle	cache milieu	copertura intermedio	diafragma Mitad	Cover Cover middle
11	8 748 511 055 0	Halter (6x)	support (6x)	PATTE FIXATION KIT MONT CAPTEUR (6x)	Supporto (6x)	Soporte de fijación (6x)	Suporte (6x)
12	8 718 223 904 0	Dichtband dreieckig	Sealing band	ruban isolant	Nastro di tenuta	Cinta aislante	Sealing band

Ersatzteilliste
 Spare parts list
 Liste des pièces de rechange
 Lista parti di ricambio
 Lista de repuestos
 Catálogo de peças de substituição

ID ESSS - 8718532914

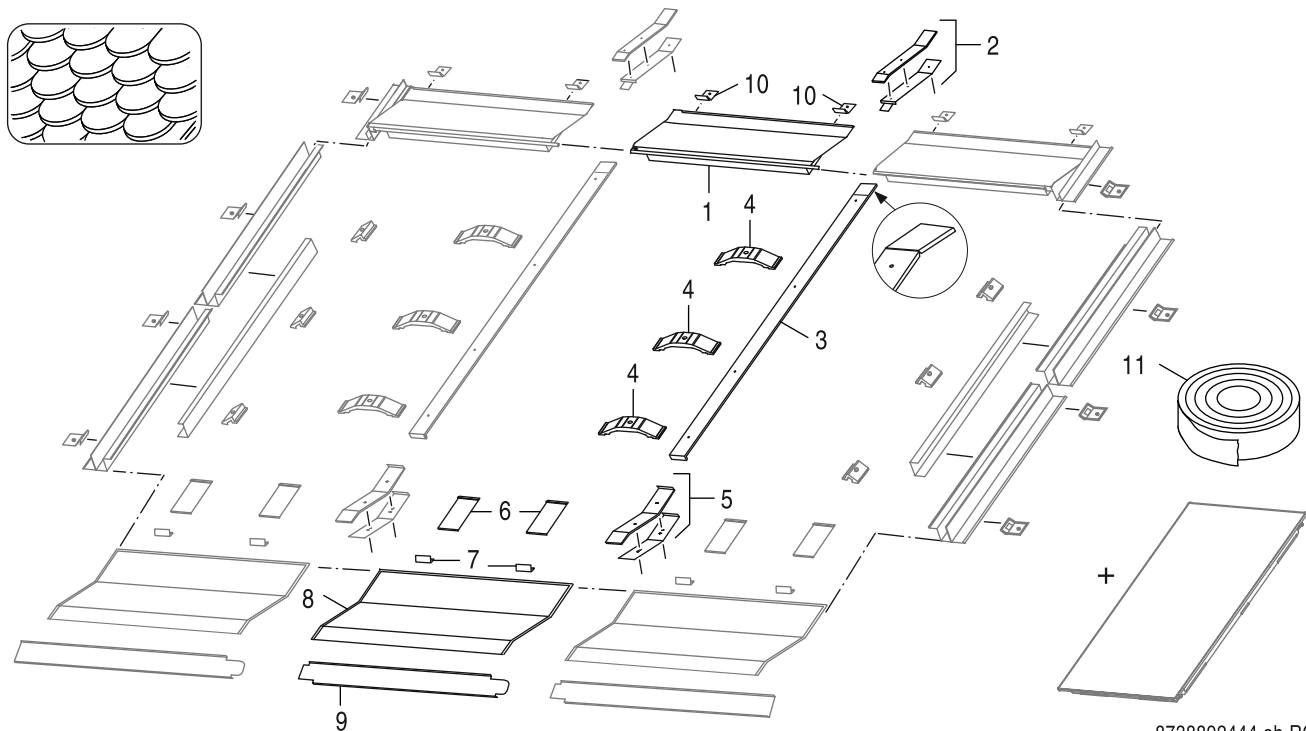

8738892444.ab.RO

	Bestell-Nr.	Bezeichnung	Description	Dénomination	Descrizioni	Descripción	Designação
1	8 718 531 710 0	Eindeckblech oben mitte	Cover top middle	tôle de protection haut milieu	Lamiera di protezione sopra intermedio	chapa de recubrimiento arriba Mitad	Cover top middle
2	8 718 533 342 0	Verbinder oben	connector set top	kit de raccordement haut	Set di collegamento sopra	set conector arriba	connector set top
3	8 718 533 341 0	Mittelschiene	Cover middle	rail milieu	rotaia intermedio	Rail	Cover middle
4	8 718 531 774 0	Montagehalter	Support	Support de montage	materiale di montaggio	material de montaje	Support
5	8 718 531 769 0	Verbinder unten	Connector bottom	kit de raccordement bas	Set di collegamento sotto	set conector debajo	Connector bottom
6	8 718 531 771 0	Montagehalter	Support	matériel de montage	materiale di montaggio	material de montaje	Support
7	8 718 531 772 0	Abrutschsicherung	Support Slipping safty	Dispositif anti-glisement	scivolo	Tope	Support Slipping safty
8	8 718 531 740 0	Eindeckblech unten mitte	Cover bottom middle	tôle de protection bas milieu	Lamiera di protezione sotto intermedio	chapa de recubrimiento debajo Mitad	Cover bottom middle
9	8 718 531 752 0	Blende mitte	Cover Cover middle	cache milieu	copertura intermedio	diafragma Mitad	Cover Cover middle
10	8 748 511 055 0	Halter (6x)	support (6x)	PATTE FIXATION KIT MONT CAPTEUR (6x)	Supporto (6x)	Soporte de fijación (6x)	Suporte (6x)
11	8 718 223 903 0	Dichtschnur UEB Schiefer	Sealing UEB slate	Cordon d'étanchéité	Cordone ermetizzante	cordón junta	Sealing UEB slate

Ersatzteilliste
Spare parts list
Liste des pièces de rechange
Lista parti di ricambio
Lista de repuestos
Catálogo de peças de substituição

ID ESSZ - 8718532911

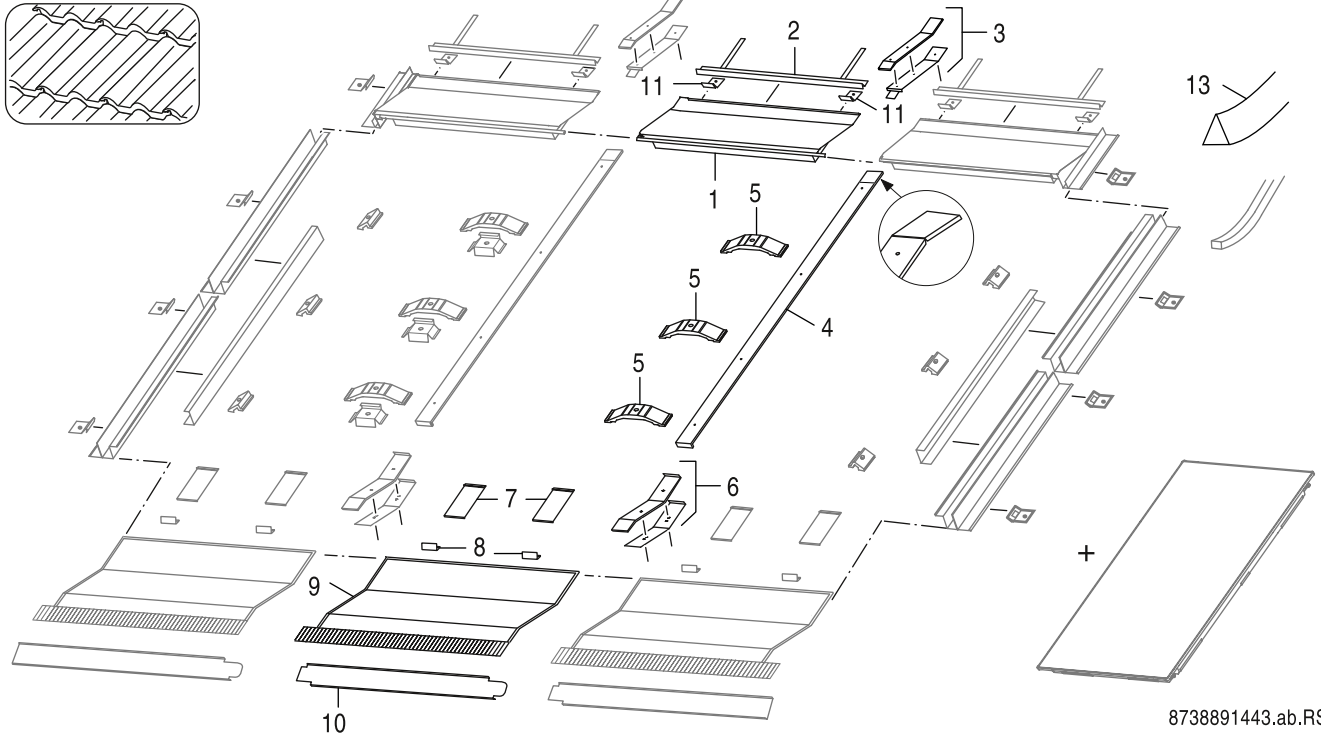

	Bestell-Nr.	Bezeichnung	Description	Dénomination	Descrizioni	Descripción	Designação
1	8 718 531 710 0	Eindeckblech oben mitte	Cover top middle	tôle de protection haut milieu	Lamiere di protezione sopra intermedio	chapa de recubrimiento arriba Mitad	Cover top middle
2	8 748 511 075 0	Schiene	Bar	Barre	Telaio	Respaldo	Caixilho
3	8 718 533 342 0	Verbinder oben	connector set top	kit de raccordement haut	Set di collegamento sopra	set conector arriba	connector set top
4	8 718 533 341 0	Mittelschiene	Cover middle	rail milieu	rotaia intermedio	Rail	Cover middle
5	8 718 531 774 0	Montagehalter	Support	Support de montage	materiale di montaggio	material de montaje	Support
6	8 718 531 767 0	Verbinder unten	Connector bottom	kit de raccordement bas	Set di collegamento sotto	set conector debajo	Connector bottom
7	8 718 531 771 0	Montagehalter	Support	matériel de montage	materiale di montaggio	material de montaje	Support
8	8 718 531 772 0	Abrutschsicherung	Support Slipping safty	Dispositif anti-glisement	scivolo	Tope	Support Slipping safty
9	8 718 531 732 0	Eindeckblech unten mitte	Cover bottom middle	tôle de protection bas milieu	Lamiere di protezione sotto intermedio	chapa de recubrimiento debajo Mitad	Cover bottom middle
10	8 718 531 752 0	Blende mitte	Cover Cover middle	cache milieu	copertura intermedio	diafragma Mitad	Cover Cover middle
11	8 748 511 055 0	Halter (6x)	support (6x)	PATTE FIXATION KIT MONT CAPTEUR (6x)	Supporto (6x)	Soporte de fijación (6x)	Suporte (6x)

Ersatzteilliste
Spare parts list
Liste des pièces de rechange
Lista parti di ricambio
Lista de repuestos
Catálogo de peças de substituição

ID ESWH - 8718532845

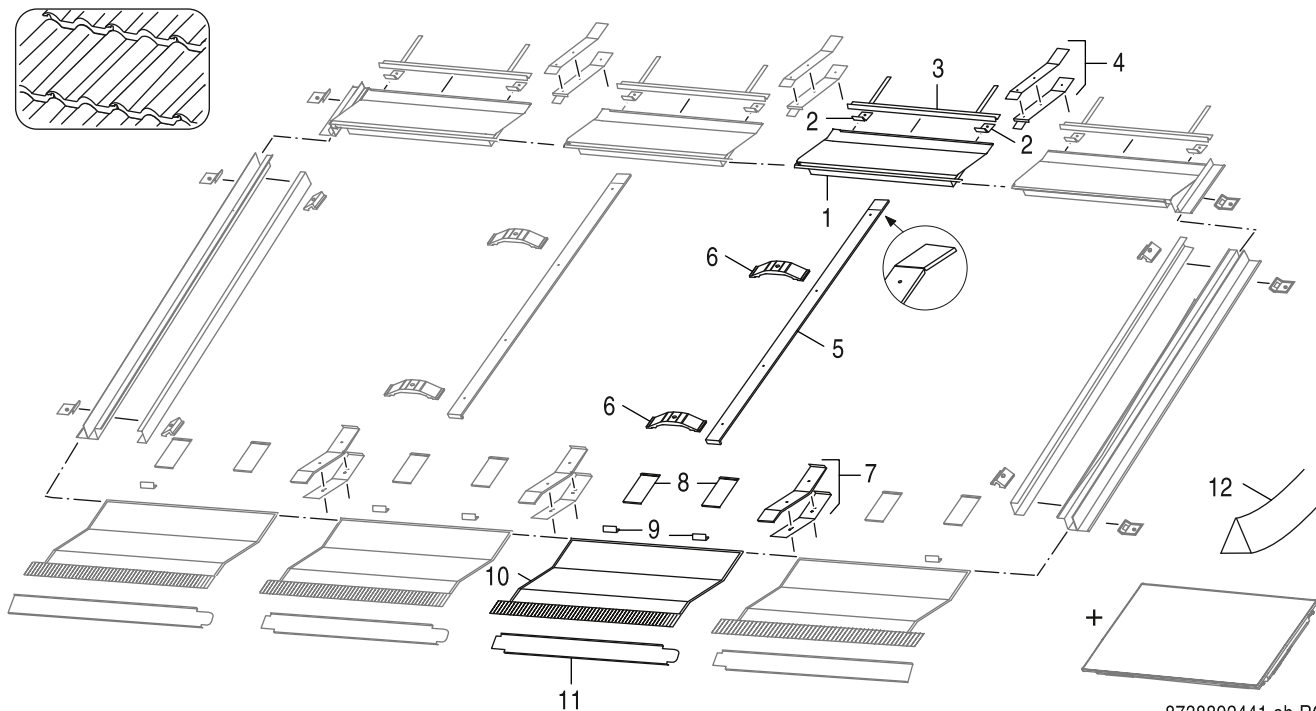

8738892441.ab.RO

	Bestell-Nr.	Bezeichnung	Description	Dénomination	Descrizioni	Descripción	Designação
1	8 718 533 321 0	Eindeckblech oben mitte	Cover top middle	tôle de recouvrement haut milieu	lamiera di copertura sopra intermedio	chapa de recubrimiento arriba Mitad	Cover top middle
2	8 748 511 055 0	Halter (6x)	support (6x)	PATTE FIXATION KIT MONT CAPTEUR (6x)	Supporto (6x)	Soporte de fijación (6x)	Suporte (6x)
3	8 748 511 075 0	Schiene	Bar	Barre	Telaio	Respaldo	Caixilho
4	8 718 533 343 0	Verbinder oben	connector set top	kit de raccordement haut	Set di collegamento sopra	set conector arriba	connector set top
5	8 718 531 760 0	Mittelschiene	Cover middle	Baguette du milieu	Parte intermedia	pieza central	Cover middle
6	8 718 531 774 0	Montagehalter	Support	Support de montage	materiale di montaggio	material de montaje	Support
7	8 718 531 766 0	Verbinder unten	Connector bottom	kit de raccordement bas	Set di collegamento sotto	set conector debajo	Connector bottom
8	8 718 531 771 0	Montagehalter	Support	matériel de montage	materiale di montaggio	material de montaje	Support
9	8 718 531 772 0	Abrutschsicherung	Support Slipping safty	Dispositif anti-glisement	scivolo	Tope	Support Slipping safty
10	8 718 533 327 0	Eindeckblech unten mitte	Cover bottom middle	tôle de recouvrement bas milieu	lamiera di copertura sotto intermedio	chapa de recubrimiento debajo Mitad	Cover bottom middle
11	8 718 533 338 0	Blende mitte	Cover middle	couvercle milieu	copertura di protezione intermedio	recubrimiento Mitad	Cover middle
12	8 718 223 904 0	Dichtband dreieckig	Sealing band	ruban isolant	Nastro di tenuta	Cinta aislante	Sealing band

Ersatzteilliste
Spare parts list
Liste des pièces de rechange
Lista parti di ricambio
Lista de repuestos
Catálogo de peças de substituição

ID ESWS - 8718532842

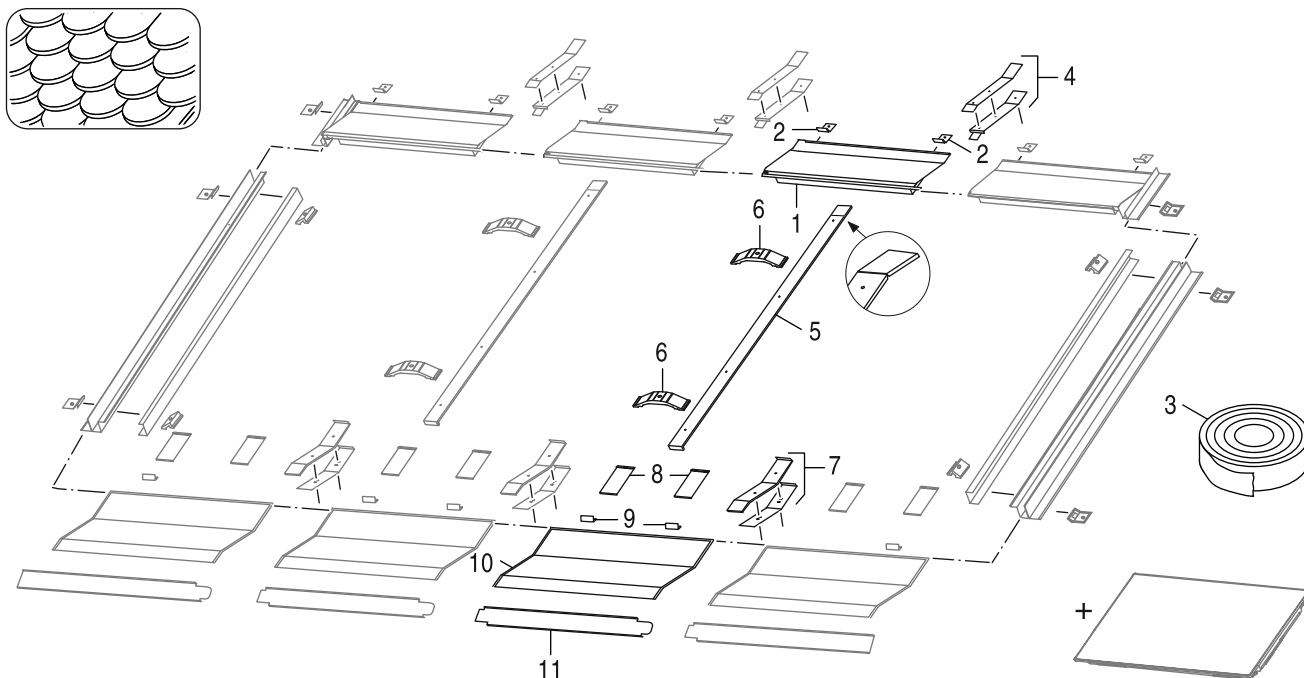

8738892440.ab.RO

	Bestell-Nr.	Bezeichnung	Description	Dénomination	Descrizioni	Descripción	Designação
1	8 718 533 318 0	Eindeckblech oben mitte	Cover top middle	tôle de recouvrement haut milieu	lamiera di copertura sopra intermedio	chapa de recubrimiento arriba Mitad	Cover top middle
2	8 748 511 055 0	Halter (6x)	support (6x)	PATTE FIXATION KIT MONT CAPTEUR (6x)	Supporto (6x)	Soporte de fijación (6x)	Suporte (6x)
3	8 718 223 903 0	Dichtschnur UEB Schiefer	Sealing UEB slate	Cordon d'étanchéité	Cordone ermetizzante	cordón junta	Sealing UEB slate
4	8 718 533 342 0	Verbinder oben	connector set top	kit de raccordement haut	Set di collegamento sopra	set conector arriba	connector set top
5	8 718 531 760 0	Mittelschiene	Cover middle	Baguette du milieu	Parte intermedia	pieza central	Cover middle
6	8 718 531 774 0	Montagehalter	Support	Support de montage	materiale di montaggio	material de montaje	Support
7	8 718 531 770 0	Verbinder unten	Connector bottom	kit de raccordement bas	Set di collegamento sotto	set conector debajo	Connector bottom
8	8 718 531 771 0	Montagehalter	Support	matériel de montage	materiale di montaggio	material de montaje	Support
9	8 718 531 772 0	Abrutschsicherung	Support Slipping safty	Dispositif anti-glisement	scivolo	Tope	Support Slipping safty
10	8 718 533 329 0	Eindeckblech unten mitte	Cover bottom middle	tôle de recouvrement bas milieu	lamiera di copertura sotto intermedio	chapa de recubrimiento debajo Mitad	Cover bottom middle
11	8 718 533 338 0	Blende mitte	Cover middle	couvercle milieu	copertura di protezione intermedio	recubrimiento Mitad	Cover middle

Ersatzteilliste
Spare parts list
Liste des pièces de rechange
Lista parti di ricambio
Lista de repuestos
Catálogo de peças de substituição

ID ESWZ - 8718532839

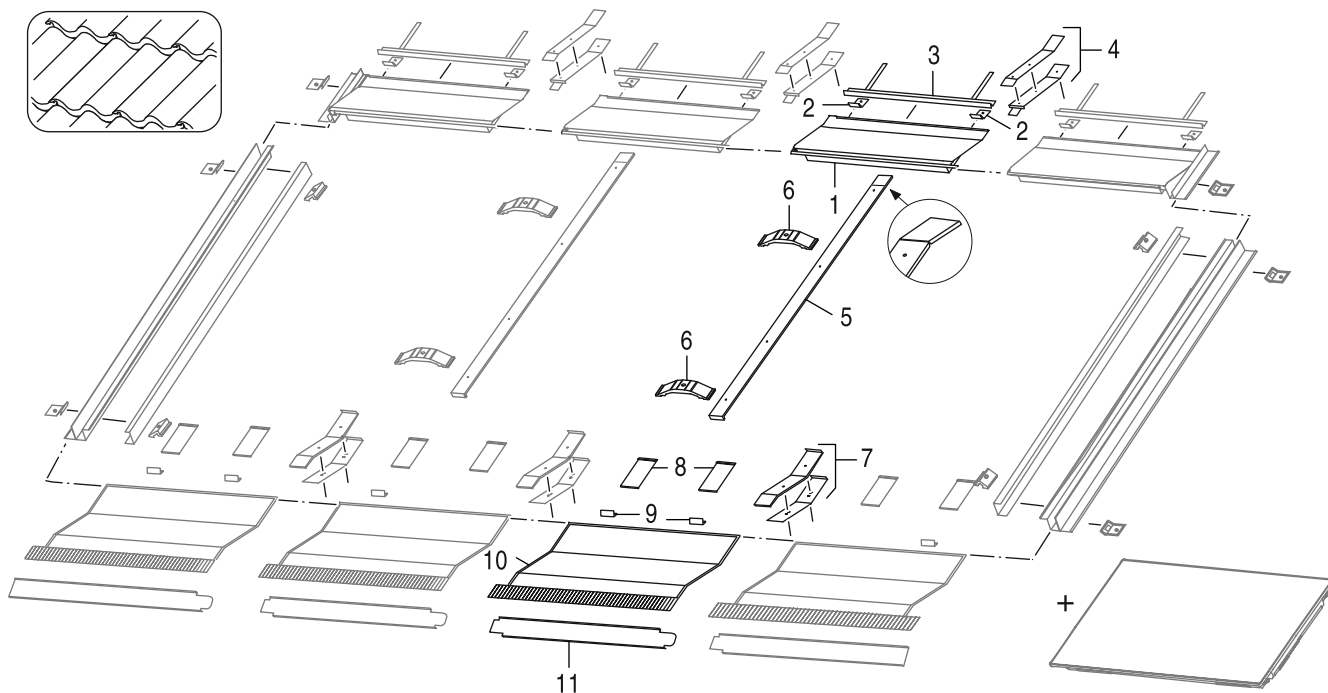

8738892439.ab.RO

	Bestell-Nr.	Bezeichnung	Description	Dénomination	Descrizioni	Descripción	Designação
1	8 718 533 318 0	Eindeckblech oben mitte	Cover top middle	tôle de recouvrement haut milieu	lamiera di copertura sopra intermedio	chapa de recubrimiento arriba Mitad	Cover top middle
2	8 748 511 055 0	Halter (6x)	support (6x)	PATTE FIXATION KIT MONT CAPTEUR (6x)	Supporto (6x)	Soporte de fijación (6x)	Suporte (6x)
3	8 748 511 075 0	Schiene	Bar	Barre	Telaio	Respaldo	Caixilho
4	8 718 533 342 0	Verbinder oben	connector set top	kit de raccordement haut	Set di collegamento sopra	set conector arriba	connector set top
5	8 718 531 760 0	Mittelschiene	Cover middle	Baguette du milieu	Parte intermedia	pieza central	Cover middle
6	8 718 531 774 0	Montagehalter	Support	Support de montage	materiale di montaggio	material de montaje	Support
7	8 718 531 768 0	Verbinder unten	Cover bottom	kit de raccordement bas	Set di collegamento sotto	set conector debajo	Cover bottom
8	8 718 531 771 0	Montagehalter	Support	matériel de montage	materiale di montaggio	material de montaje	Support
9	8 718 531 772 0	Abrutschsicherung	Support Slipping safty	Dispositif anti-glisement	scivolo	Tope	Support Slipping safty
10	8 718 533 324 0	Eindeckblech unten mitte	Cover bottom middle	tôle de recouvrement bas milieu	lamiera di copertura sotto intermedio	chapa de recubrimiento debajo Mitad	Cover bottom middle
11	8 718 533 338 0	Blende mitte	Cover middle	couvercle milieu	copertura di protezione intermedio	recubrimiento Mitad	Cover middle

Ersatzteilliste
Spare parts list
Liste des pièces de rechange
Lista parti di ricambio
Lista de repuestos
Catálogo de peças de substituição

ID GSSH - 8718532916

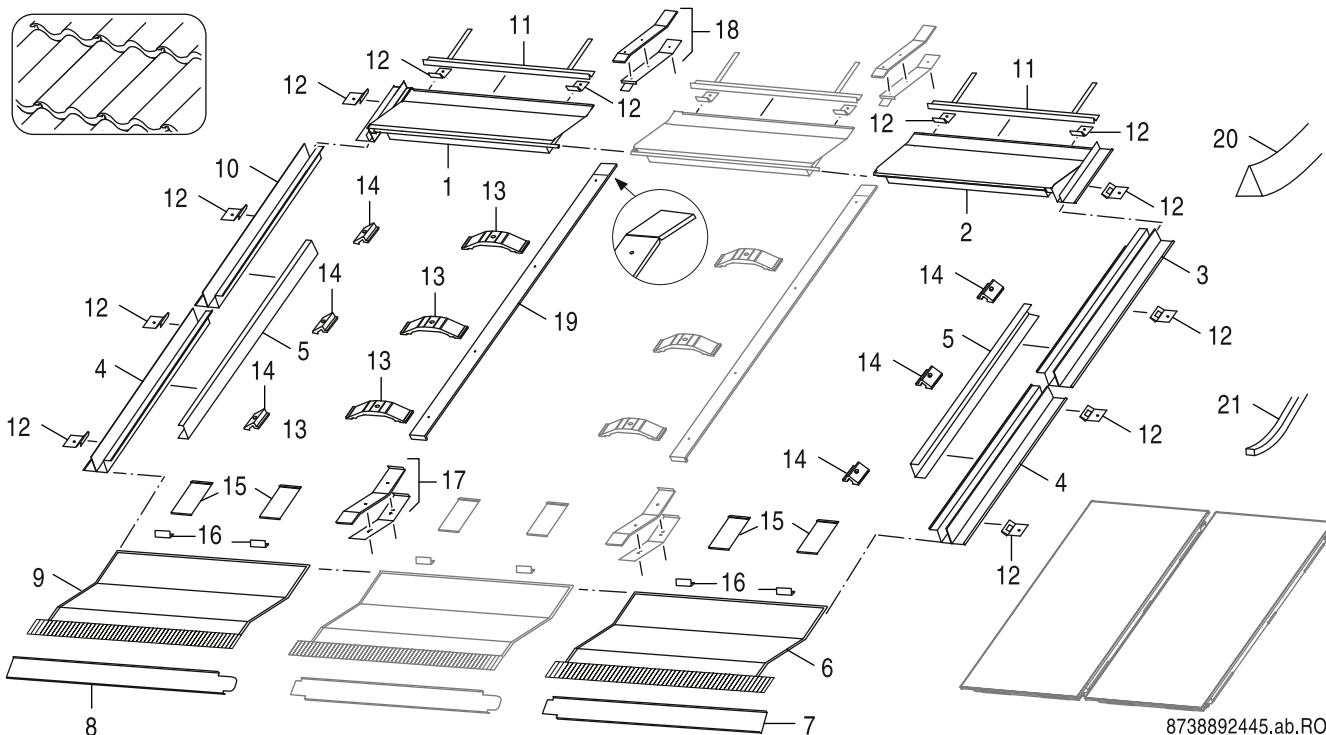

8738892445.ab.RO

	Bestell-Nr.	Bezeichnung	Description	Dénomination	Descrizioni	Descripción	Designação
1	8 718 531 712 0	Eindeckblech oben links	Cover top left	tôle de protection haut gauche	Lamiera di protezione sopra sinistra	chapa de recubrimiento arriba izquierda	Cover top left
2	8 718 531 713 0	Eindeckblech oben rechts	Cover top right	tôle de protection haut droite	Lamiera di protezione sopra destra	chapa de recubrimiento arriba derecha	Cover top right
3	8 718 531 724 0	Eindeckblech rechts oben	Cover right top	tôle de protection droite haut	Lamiera di protezione destra sopra	chapa de recubrimiento derecha arriba	Cover right top
4	8 718 531 722 0	Eindeckblech rechts unten	Cover bottom right	tôle de protection droite bas	Lamiera di protezione destra sotto	chapa de recubrimiento derecha debajo	Cover bottom right
5	8 718 531 748 0	Stützblech senkrecht	Sheet vertical	tôle vertical	Lamierino verticale	chapa vertical	Sheet vertical
6	8 718 531 735 0	Eindeckblech unten rechts	Cover bottom right	tôle de protection bas droite	Lamiera di protezione sotto destra	chapa de recubrimiento debajo derecha	Cover bottom right
7	8 718 531 751 0	Blende rechts	Cover right	cache droite	copertura destra	diafragma derecha	Cover right
8	8 718 531 750 0	Blende links	Cover left	cache gauche	copertura sinistra	diafragma izquierda	Cover left
9	8 718 531 734 0	Eindeckblech unten links	Cover bottom left	tôle de protection bas gauche	Lamiera di protezione sotto sinistra	chapa de recubrimiento debajo izquierda	Cover bottom left
10	8 718 531 725 0	Eindeckblech links oben	Cover left top	tôle de protection gauche haut	Lamiera di protezione sinistra sopra	chapa de recubrimiento izquierda arriba	Cover left top
11	8 748 511 075 0	Schiene	Bar	Barre	Telaio	Respaldo	Caixilho
12	8 748 511 055 0	Halter (6x)	support (6x)	PATTE FIXATION KIT MONT CAPTEUR (6x)	Supporto (6x)	Soporte de fijación (6x)	Suporte (6x)
13	8 718 531 774 0	Montagehalter	Support	Support de montage	materiale di montaggio	material de montaje	Support
14	8 718 531 773 0	Montagehalter seitlich	Support side	Support latéral	materiale di montaggio laterale	material de montaje lateral	Support side
15	8 718 531 771 0	Montagehalter	Support	matériel de montage	materiale di montaggio	material de montaje	Support
16	8 718 531 772 0	Abrutschsicherung	Support Slipping safty	Dispositif anti-glisement	scivolo	Tope	Support Slipping safty
17	8 718 531 765 0	Verbinder unten	Connector bottom	kit de raccordement bas	Set di collegamento sotto	set conector debajo	Connector bottom
18	8 718 533 343 0	Verbinder oben	connector set top	kit de raccordement haut	Set di collegamento sopra	set conector arriba	connector set top
19	8 718 533 341 0	Mittelschiene	Cover middle	rail milieu	rotaia intermedio	Rail	Cover middle
20	8 718 223 904 0	Dichtband dreieckig	Sealing band	ruban isolant	Nastro di tenuta	Cinta aislante	Sealing band
21	6 304 637 5	Dichtband Hannoband 10x10x6300 verp	Tape Hannoband 10x10x6300	Bande d'étanchéité p/tuiles creuses	Guarnizione Hannoband 10x10x6300	junta Hannoband 10x10x6300	vedação Hannoband 10x10x6300

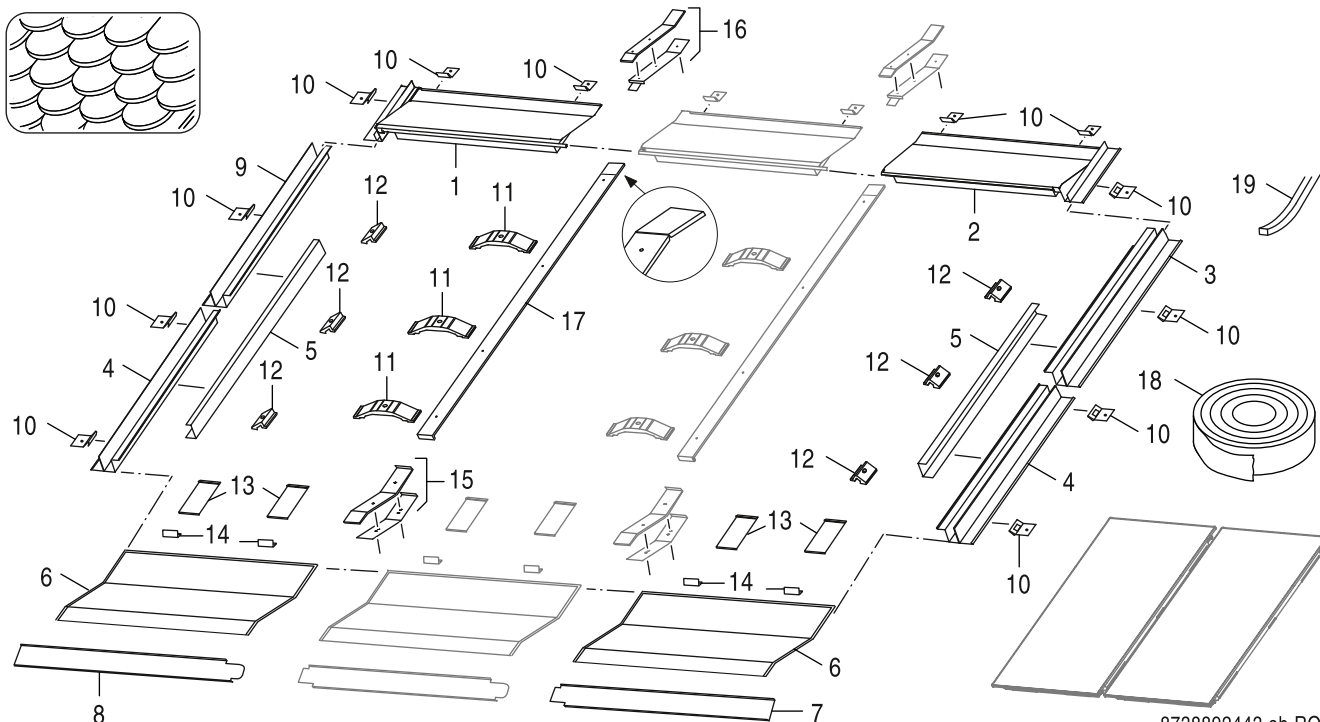

8738892443.ab.RO

	Bestell-Nr.	Bezeichnung	Description	Dénomination	Descrizioni	Descripción	Designação
1	8 718 531 708 0	Eindeckblech oben links	Cover top left	tôle de protection haut gauche	Lamiera di protezione sopra sinistra	chapa de recubrimiento arriba izquierda	Cover top left
2	8 718 531 709 0	Eindeckblech oben rechts	Cover top right	tôle de protection haut droite	Lamiera di protezione sopra destra	chapa de recubrimiento arriba derecha	Cover top right
3	8 718 531 728 0	Eindeckblech rechts oben	Cover right top	tôle de protection droite haut	Lamiera di protezione destra sopra	chapa de recubrimiento derecha arriba	Cover right top
4	8 718 531 726 0	Eindeckblech rechts unten	Cover right bottom	tôle de protection droite bas	Lamiera di protezione destra sotto	chapa de recubrimiento derecha debajo	Cover right bottom
5	8 718 531 748 0	Stützblech senkrecht	Sheet vertical	tôle vertical	Lamierino verticale	chapa vertical	Sheet vertical
6	8 718 531 738 0	Eindeckblech unten links rechts	Cover bottom left right	tôle de protection bas gauche droite	Lamiera di protezione sotto sinistra des	chapa de recubrimiento debajo izquierda	Cover bottom left right
7	8 718 531 751 0	Blende rechts	Cover right	cache droite	copertura destra	diafragma derecha	Cover right
8	8 718 531 750 0	Blende links	Cover left	cache gauche	copertura sinistra	diafragma izquierda	Cover left
9	8 718 531 729 0	Eindeckblech links oben	Cover left top	tôle de protection gauche haut	Lamiera di protezione sinistra sopra	chapa de recubrimiento izquierda arriba	Cover left top
10	8 748 511 055 0	Halter (6x)	support (6x)	PATTE FIXATION KIT MONT CAPTEUR (6x)	Supporto (6x)	Soporte de fijación (6x)	Suporte (6x)
11	8 718 531 774 0	Montagehalter	Support	Support de montage	materiale di montaggio	material de montaje	Support
12	8 718 531 773 0	Montagehalter seitlich	Support side	Support latéral	materiale di montaggio laterale	material de montaje lateral	Support side
13	8 718 531 771 0	Montagehalter	Support	matériel de montage	materiale di montaggio	material de montaje	Support
14	8 718 531 772 0	Abrutschsicherung	Support Slipping safty	Dispositif anti-glisement	scivolo	Tope	Support Slipping safty
15	8 718 531 769 0	Verbinder unten	Connector bottom	kit de raccordement bas	Set di collegamento sotto	set conector debajo	Connector bottom
16	8 718 533 342 0	Verbinder oben	connector set top	kit de raccordement haut	Set di collegamento sopra	set conector arriba	connector set top
17	8 718 533 341 0	Mittelschiene	Cover middle	rail milieu	rotaia intermedio	Rail	Cover middle
18	8 718 223 903 0	Dichtsnur UEB Schiefer	Sealing UEB slate	Cordon d'étanchéité	Cordone ermetizzante	cordón junta	Sealing UEB slate
19	6 304 637 5	Dichtband Hannoband 10x10x6300 verp	Tape Hannoband 10x10x6300	Bande d'étanchéité p/tuiles creuses	Guarnizione Hannoband 10x10x6300	junta Hannoband 10x10x6300	vedação Hannoband 10x10x6300

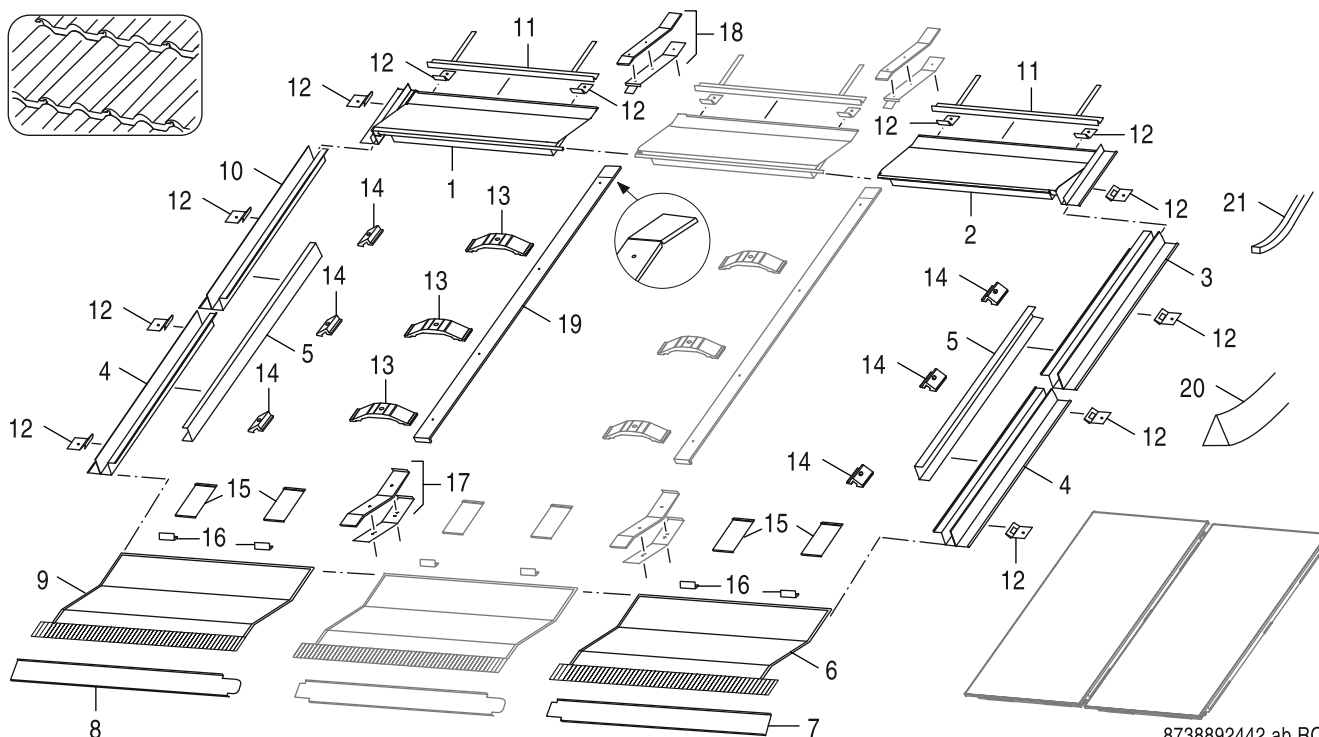

	Bestell-Nr.	Bezeichnung	Description	Dénomination	Descrizioni	Descripción	Designação
1	8 718 531 708 0	Eindeckblech oben links	Cover top left	tôle de protection haut gauche	Lamiera di protezione sopra sinistra	chapa de recubrimiento arriba izquierda	Cover top left
2	8 718 531 709 0	Eindeckblech oben rechts	Cover top right	tôle de protection haut droite	Lamiera di protezione sopra destra	chapa de recubrimiento arriba derecha	Cover top right
3	8 718 531 728 0	Eindeckblech rechts oben	Cover right top	tôle de protection droite haut	Lamiera di protezione destra sopra	chapa de recubrimiento derecha arriba	Cover right top
4	8 718 531 726 0	Eindeckblech rechts unten	Cover right bottom	tôle de protection droite bas	Lamiera di protezione destra sotto	chapa de recubrimiento derecha debajo	Cover right bottom
5	8 718 531 748 0	Stützblech senkrecht	Sheet vertical	tôle vertical	Lamierino verticale	chapa vertical	Sheet vertical
6	8 718 531 731 0	Eindeckblech unten rechts	Cover bottom right	tôle de protection bas droite	Lamiera di protezione sotto destra	chapa de recubrimiento debajo derecha	Cover bottom right
7	8 718 531 751 0	Blende rechts	Cover right	cache droite	copertura destra	diafragma derecha	Cover right
8	8 718 531 750 0	Blende links	Cover left	cache gauche	copertura sinistra	diafragma izquierda	Cover left
9	8 718 531 730 0	Eindeckblech unten links	Cover bottom left	tôle de protection bas gauche	Lamiera di protezione sotto sinistra	chapa de recubrimiento debajo izquierda	Cover bottom left
10	8 718 531 729 0	Eindeckblech links oben	Cover left top	tôle de protection gauche haut	Lamiera di protezione sinistra sopra	chapa de recubrimiento izquierda arriba	Cover left top
11	8 748 511 075 0	Schiene	Bar	Barre	Telaio	Respaldo	Caixilho
12	8 748 511 055 0	Halter (6x)	support (6x)	PATTE FIXATION KIT MONT CAPTEUR (6x)	Supporto (6x)	Soporte de fijación (6x)	Suporte (6x)
13	8 718 531 774 0	Montagehalter	Support	Support de montage	materiale di montaggio	material de montaje	Support
14	8 718 531 773 0	Montagehalter seitlich	Support side	Support latéral	materiale di montaggio laterale	material de montaje lateral	Support side
15	8 718 531 771 0	Montagehalter	Support	matériel de montage	materiale di montaggio	material de montaje	Support
16	8 718 531 772 0	Abrutschsicherung	Support Slipping safty	Dispositif anti-glisement	scivolo	Tope	Support Slipping safty
17	8 718 531 767 0	Verbinder unten	Connector bottom	kit de raccordement bas	Set di collegamento sotto	set conector debajo	Connector bottom
18	8 718 533 342 0	Verbinder oben	connector set top	kit de raccordement haut	Set di collegamento sopra	set conector arriba	connector set top
19	8 718 533 341 0	Mittelschiene	Cover middle	rail milieu	rotaia intermedio	Rail	Cover middle
20	8 718 223 904 0	Dichtband dreieckig	Sealing band	ruban isolant	Nastro di tenuta	Cinta aislante	Sealing band
21	6 304 637 5	Dichtband Hannoband 10x10x6300 verp	Tape Hannoband 10x10x6300	Bande d'étanchéité p/tuiles creuses	Guarnizione Hannoband 10x10x6300	junta Hannoband 10x10x6300	vedação Hannoband 10x10x6300

Ersatzteilliste
 Spare parts list
 Liste des pièces de rechange
 Lista parti di ricambio
 Lista de repuestos
 Catálogo de peças de substituição

ID GSWH - 8718532844

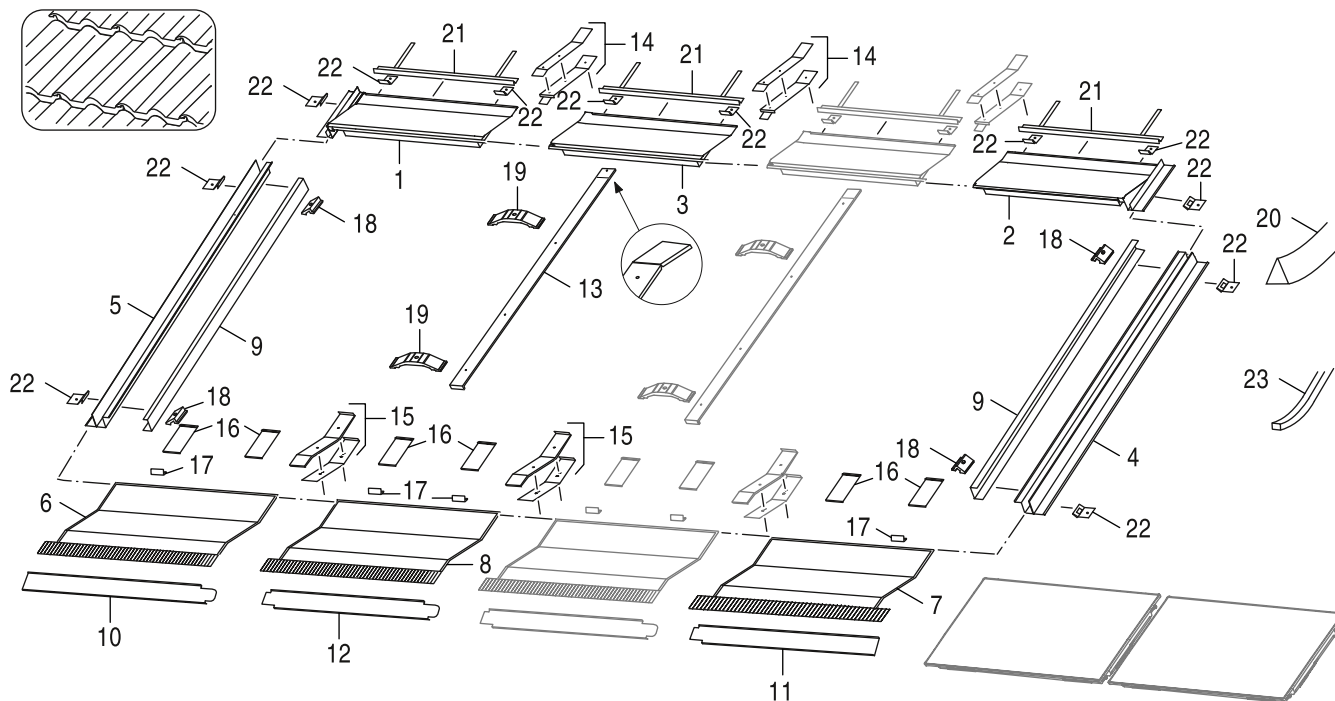

8738892438.ab.RO

	Bestell-Nr.	Bezeichnung	Description	Dénomination	Descrizioni	Descripción	Designação
1	8 718 533 319 0	Eindeckblech oben links	Cover top left	tôle de recouvrement haut gauche	lamiera di copertura sopra sinistra	chapa de recubrimiento arriba izquierda	Cover top left
2	8 718 533 320 0	Eindeckblech oben rechts	Cover top right	tôle de recouvrement haut droite	lamiera di copertura sopra destra	chapa de recubrimiento arriba derecha	Cover top right
3	8 718 533 321 0	Eindeckblech oben mitte	Cover top middle	tôle de recouvrement haut milieu	lamiera di copertura sopra intermedio	chapa de recubrimiento arriba Mitad	Cover top middle
4	8 718 531 724 0	Eindeckblech rechts oben	Cover right top	tôle de protection droite haut	Lamiera di protezione destra sopra	chapa de recubrimiento derecha arriba	Cover right top
5	8 718 531 725 0	Eindeckblech links oben	Cover left top	tôle de protection gauche haut	Lamiera di protezione sinistra sopra	chapa de recubrimiento izquierda arriba	Cover left top
6	8 718 533 325 0	Eindeckblech unten links	Cover bottom left	tôle de recouvrement bas gauche	lamiera di copertura sotto sinistra	chapa de recubrimiento debajo izquierda	Cover bottom left
7	8 718 533 326 0	Eindeckblech unten rechts	Cover bottom right	tôle de recouvrement bas droite	lamiera di copertura sotto destra	chapa de recubrimiento debajo derecha	Cover bottom right
8	8 718 533 327 0	Eindeckblech unten mitte	Cover bottom middle	tôle de recouvrement bas milieu	lamiera di copertura sotto intermedio	chapa de recubrimiento debajo Mitad	Cover bottom middle
9	8 718 531 749 0	Stützblech waagerecht	Sheet horizontal	tôle horizontal	Lamierino orizzontale	chapa horizontal	Sheet horizontal
10	8 718 533 336 0	Blende links	cover panel links	tôle de recouvrement links	pannello di copertura links	chapa de recubrimiento links	cover panel links
11	8 718 533 337 0	Blende rechts	cover panel rechts	tôle de recouvrement rechts	pannello di copertura rechts	chapa de recubrimiento rechts	cover panel rechts
12	8 718 533 338 0	Blende mitte	Cover middle	couvercle milieu	copertura di protezione intermedio	recubrimiento Mitad	Cover middle
13	8 718 531 760 0	Mittelschiene	Cover middle	Baguette du milieu	Parte intermedia	pieza central	Cover middle
14	8 718 533 343 0	Verbinder oben	connector set top	kit de raccordement haut	Set di collegamento sopra	set conector arriba	connector set top
15	8 718 531 766 0	Verbinder unten	Connector bottom	kit de raccordement bas	Set di collegamento sotto	set conector debajo	Connector bottom
16	8 718 531 771 0	Montagehalter	Support	matériel de montage	materiale di montaggio	material de montaje	Support
17	8 718 531 772 0	Abrutschsicherung	Support Slipping safty	Dispositif anti-glisement	scivolo	Tope	Support Slipping safty
18	8 718 531 773 0	Montagehalter seitlich	Support side	Support latéral	materiale di montaggio laterale	material de montaje lateral	Support side
19	8 718 531 774 0	Montagehalter	Support	Support de montage	materiale di montaggio	material de montaje	Support
20	8 718 223 904 0	Dichtband dreieckig	Sealing band	ruban isolant	Nastro di tenuta	Cinta aislante	Sealing band
21	8 748 511 075 0	Schiene	Bar	Barre	Telaio	Respaldo	Caixilho
22	8 748 511 055 0	Halter (6x)	support (6x)	PATTE FIXATION KIT MONT CAPTEUR (6x)	Supporto (6x)	Soporte de fijación (6x)	Suporte (6x)
23	6 304 637 5	Dichtband Hannoband 10x10x6300 verp	Tape Hannoband 10x10x6300	Bande d'étanchéité p/tuiles creuses	Guarnizione Hannoband 10x10x6300	junta Hannoband 10x10x6300	vedação Hannoband 10x10x6300

Ersatzteilliste
Spare parts list
Liste des pièces de rechange
Lista parti di ricambio
Lista de repuestos
Catálogo de peças de substituição

ID GSWS - 8718532841

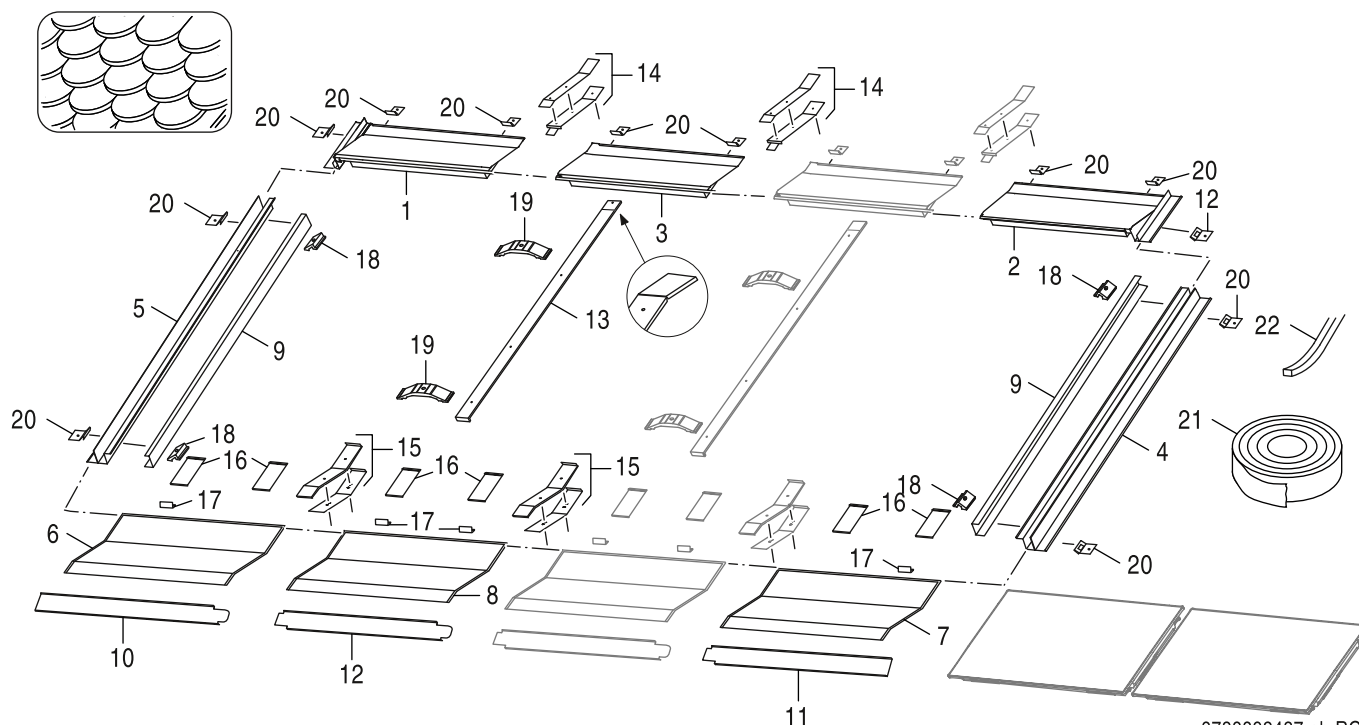

8738892437.ab.RO

	Bestell-Nr.	Bezeichnung	Description	Dénomination	Descrizioni	Descripción	Designação
1	8 718 533 316 0	Eindeckblech oben links	flashing panel top left	tôle de recouvrement haut gauche	lamiera di copertura sopra sinistra	chapa de recubrimiento arriba izquierda	flashing panel top left
2	8 718 533 317 0	Eindeckblech oben rechts	flashing panel top right	tôle de recouvrement haut droite	lamiera di copertura sopra destra	chapa de recubrimiento arriba derecha	flashing panel top right
3	8 718 533 318 0	Eindeckblech oben mitte	Cover top middle	tôle de recouvrement haut milieu	lamiera di copertura sopra intermedio	chapa de recubrimiento arriba Mitad	Cover top middle
4	8 718 531 728 0	Eindeckblech rechts oben	Cover right top	tôle de protection droite haut	Lamiera di protezione destra sopra	chapa de recubrimiento derecha arriba	Cover right top
5	8 718 531 729 0	Eindeckblech links oben	Cover left top	tôle de protection gauche haut	Lamiera di protezione sinistra sopra	chapa de recubrimiento izquierda arriba	Cover left top
6	8 718 533 328 0	Eindeckblech unten links/ rechts	flashing panel bottom left/ right	tôle de recouvrement bas gauche/droite	lamiera di copertura sotto sinistra/dest	chapa de recubrimiento debajo iz./ de.	flashing panel bottom left/ right
7	8 718 533 328 0	Eindeckblech unten links/ rechts	flashing panel bottom left/ right	tôle de recouvrement bas gauche/droite	lamiera di copertura sotto sinistra/dest	chapa de recubrimiento debajo iz./ de.	flashing panel bottom left/ right
8	8 718 533 329 0	Eindeckblech unten mitte	Cover bottom middle	tôle de recouvrement bas milieu	lamiera di copertura sotto intermedio	chapa de recubrimiento debajo Mitad	Cover bottom middle
9	8 718 531 749 0	Stützblech waagerecht	Sheet horizontal	tôle horizontal	Lamierino orizzontale	chapa horizontal	Sheet horizontal
10	8 718 533 336 0	Blende links	cover panel links	tôle de recouvrement links	pannello di copertura links	chapa de recubrimiento links	cover panel links
11	8 718 533 337 0	Blende rechts	cover panel rechts	tôle de recouvrement rechts	pannello di copertura rechts	chapa de recubrimiento rechts	cover panel rechts
12	8 718 533 338 0	Blende mitte	Cover middle	couvercle milieu	copertura di protezione intermedio	recubrimiento Mitad	Cover middle
13	8 718 531 760 0	Mittelschiene	Cover middle	Baguette du milieu	Parte intermedia	pieza central	Cover middle
14	8 718 533 342 0	Verbinder oben	connector set top	kit de raccordement haut	Set di collegamento sopra	set conector arriba	connector set top
15	8 718 531 770 0	Verbinder unten	Connector bottom	kit de raccordement bas	Set di collegamento sotto	set conector debajo	Connector bottom
16	8 718 531 771 0	Montagehalter	Support	matériel de montage	materiale di montaggio	material de montaje	Support
17	8 718 531 772 0	Abbrutschsicherung	Support Slipping safty	Dispositif anti-glisement	scivolo	Tope	Support Slipping safty
18	8 718 531 773 0	Montagehalter seitlich	Support side	Support latéral	materiale di montaggio laterale	material de montaje lateral	Support side
19	8 718 531 774 0	Montagehalter	Support	Support de montage	materiale di montaggio	material de montaje	Support
20	8 748 511 055 0	Halter (6x)	support (6x)	PATTE FIXATION KIT MONT CAPTEUR (6x)	Supporto (6x)	Soporte de fijación (6x)	Suporte (6x)
21	8 718 223 903 0	Dichtschnur UEB Schiefer	Sealing UEB slate	Cordon d'étanchéité	Cordone ermetizzante	cordón junta	Sealing UEB slate
22	6 304 637 5	Dichtband Hannoband 10x10x6300 verp	Tape Hannoband 10x10x6300	Bande d'étanchéité p/tuiles creuses	Guarnizione Hannoband 10x10x6300	junta Hannoband 10x10x6300	vedação Hannoband 10x10x6300

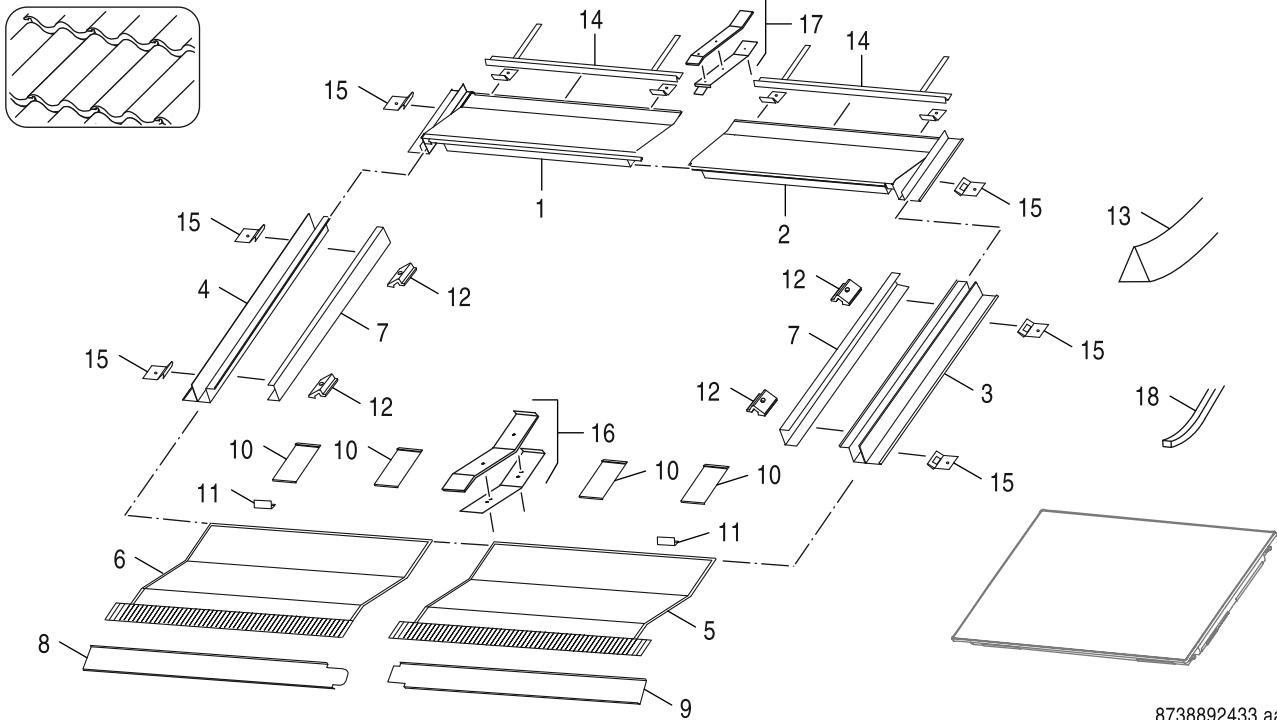

8738892433.aa.RO

	Bestell-Nr.	Bezeichnung	Description	Dénomination	Descrizioni	Descripción	Designação
1	8 718 533 316 0	Eindeckblech oben links	flashing panel top left	tôle de recouvrement haut gauche	lamiera di copertura sopra sinistra	chapa de recubrimiento arriba izquierda	flashing panel top left
2	8 718 533 317 0	Eindeckblech oben rechts	flashing panel top right	tôle de recouvrement haut droite	lamiera di copertura sopra destra	chapa de recubrimiento arriba derecha	flashing panel top right
3	8 718 531 728 0	Eindeckblech rechts oben	Cover right top	tôle de protection droite haut	Lamiera di protezione destra sopra	chapa de recubrimiento derecha arriba	Cover right top
4	8 718 531 729 0	Eindeckblech links oben	Cover left top	tôle de protection gauche haut	Lamiera di protezione sinistra sopra	chapa de recubrimiento izquierda arriba	Cover left top
5	8 718 533 323 0	Eindeckblech unten rechts	Cover bottom right	tôle de recouvrement bas droite	lamiera di copertura sotto destra	chapa de recubrimiento debajo derecha	Cover bottom right
6	8 718 533 322 0	Eindeckblech unten links	Cover bottom left	tôle de recouvrement bas gauche	lamiera di copertura sotto sinistra	chapa de recubrimiento debajo izquierda	Cover bottom left
7	8 718 531 749 0	Stützblech waagrecht	Sheet horizontal	tôle horizontal	Lamierino orizzontale	chapa horizontal	Sheet horizontal
8	8 718 533 336 0	Blende links	cover panel links	tôle de recouvrement links	pannello di copertura links	chapa de recubrimiento links	cover panel links
9	8 718 533 337 0	Blende rechts	cover panel rechts	tôle de recouvrement rechts	pannello di copertura rechts	chapa de recubrimiento rechts	cover panel rechts
10	8 718 531 771 0	Montagehalter	Support	matériel de montage	materiale di montaggio	material de montaje	Support
11	8 718 531 772 0	Abbrutschsicherung	Support Slipping safty	Dispositif anti-glissement	scivolo	Tope	Support Slipping safty
12	8 718 531 773 0	Montagehalter seitlich	Support side	Support latéral	materiale di montaggio laterale	material de montaje lateral	Support side
13	8 718 223 904 0	Dichtband dreieckig	Sealing band	ruban isolant	Nastro di tenuta	Cinta aislante	Sealing band
14	8 748 511 075 0	Schiene	Bar	Barre	Telaio	Respaldo	Caixilho
15	8 748 511 055 0	Halter (6x)	support (6x)	PATTE FIXATION KIT MONT CAPTEUR (6x)	Supporto (6x)	Soporte de fijación (6x)	Suporte (6x)
16	8 718 531 768 0	Verbinder unten	Cover bottom	kit de raccordement bas	Set di collegamento sotto	set conector debajo	Cover bottom
17	8 718 533 342 0	Verbinder oben	connector set top	kit de raccordement haut	Set di collegamento sopra	set conector arriba	connector set top
18	6 304 637 5	Dichtband Hannoband 10x10x6300 verp	Tape Hannoband 10x10x6300	Bande d'étanchéité p/tuiles creuses	Guarnizione Hannoband 10x10x6300	junta Hannoband 10x10x6300	vedação Hannoband 10x10x6300

Ersatzteilliste
 Spare parts list
 Liste des pièces de rechange
 Lista parti di ricambio
 Lista de repuestos
 Catálogo de peças de substituição

ID GSWZ - 8718532838

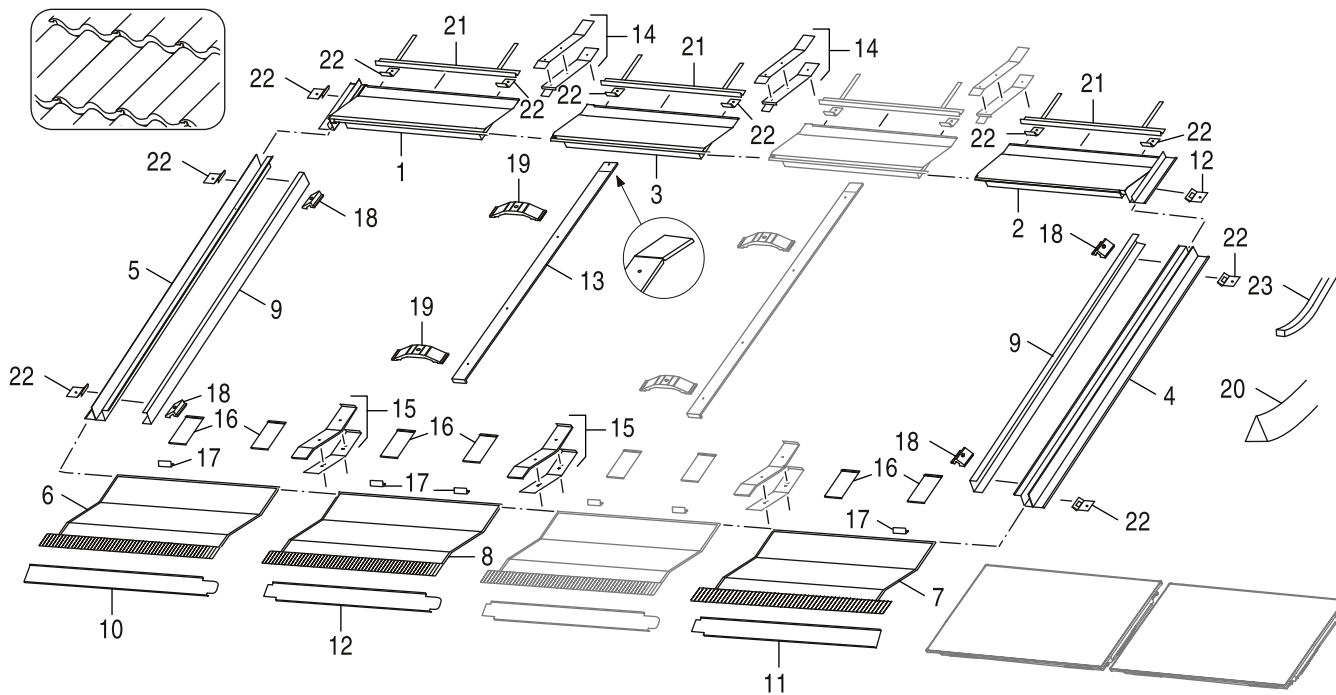

8738892436.ab.RO

	Bestell-Nr.	Bezeichnung	Description	Dénomination	Descrizioni	Descripción	Designação
1	8 718 533 316 0	Eindeckblech oben links	flashing panel top left	tôle de recouvrement haut gauche	lamiera di copertura sopra sinistra	chapa de recubrimiento arriba izquierda	flashing panel top left
2	8 718 533 317 0	Eindeckblech oben rechts	flashing panel top right	tôle de recouvrement haut droite	lamiera di copertura sopra destra	chapa de recubrimiento arriba derecha	flashing panel top right
3	8 718 533 318 0	Eindeckblech oben mitte	Cover top middle	tôle de recouvrement haut milieu	lamiera di copertura sopra intermedio	chapa de recubrimiento arriba Mitad	Cover top middle
4	8 718 531 728 0	Eindeckblech rechts oben	Cover right top	tôle de protection droite haut	Lamiera di protezione destra sopra	chapa de recubrimiento derecha arriba	Cover right top
5	8 718 531 729 0	Eindeckblech links oben	Cover left top	tôle de protection gauche haut	Lamiera di protezione sinistra sopra	chapa de recubrimiento izquierda arriba	Cover left top
6	8 718 533 322 0	Eindeckblech unten links	Cover bottom left	tôle de recouvrement bas gauche	lamiera di copertura sotto sinistra	chapa de recubrimiento debajo izquierda	Cover bottom left
7	8 718 533 323 0	Eindeckblech unten rechts	Cover bottom right	tôle de recouvrement bas droite	lamiera di copertura sotto destra	chapa de recubrimiento debajo derecha	Cover bottom right
8	8 718 533 324 0	Eindeckblech unten mitte	Cover bottom middle	tôle de recouvrement bas milieu	lamiera di copertura sotto intermedio	chapa de recubrimiento debajo Mitad	Cover bottom middle
9	8 718 531 749 0	Stützblech waagerecht	Sheet horizontal	tôle horizontal	Lamierino orizzontale	chapa horizontal	Sheet horizontal
10	8 718 533 336 0	Blende links	cover panel links	tôle de recouvrement links	pannello di copertura links	chapa de recubrimiento links	cover panel links
11	8 718 533 337 0	Blende rechts	cover panel rechts	tôle de recouvrement rechts	pannello di copertura rechts	chapa de recubrimiento rechts	cover panel rechts
12	8 718 533 338 0	Blende mitte	Cover middle	couvercle milieu	copertura di protezione intermedio	recubrimiento Mitad	Cover middle
13	8 718 531 760 0	Mittelschiene	Cover middle	Baguette du milieu	Parte intermedia	pieza central	Cover middle
14	8 718 533 342 0	Verbinder oben	connector set top	kit de raccordement haut	Set di collegamento sopra	set conector arriba	connector set top
15	8 718 531 768 0	Verbinder unten	Cover bottom	kit de raccordement bas	Set di collegamento sotto	set conector debajo	Cover bottom
16	8 718 531 771 0	Montagehalter	Support	matériel de montage	materiale di montaggio	material de montaje	Support
17	8 718 531 772 0	Abbrutschsicherung	Support Slipping safty	Dispositif anti-glisement	scivolo	Tope	Support Slipping safty
18	8 718 531 773 0	Montagehalter seitlich	Support side	Support latéral	materiale di montaggio laterale	material de montaje lateral	Support side
19	8 718 531 774 0	Montagehalter	Support	Support de montage	materiale di montaggio	material de montaje	Support
20	8 718 223 904 0	Dichtband dreieckig	Sealing band	ruban isolant	Nastro di tenuta	Cinta aislante	Sealing band
21	8 748 511 075 0	Schiene	Bar	Barre	Telaio	Respaldo	Caixilho
22	8 748 511 055 0	Halter (6x)	support (6x)	PATTE FIXATION KIT MONT CAPTEUR (6x)	Supporto (6x)	Soporte de fijación (6x)	Suporte (6x)
23	6 304 637 5	Dichtband Hannoband 10x10x6300 verp	Tape Hannoband 10x10x6300	Bande d'étanchéité p/tuiles creuses	Guarnizione Hannoband 10x10x6300	junta Hannoband 10x10x6300	vedação Hannoband 10x10x6300

Ersatzteilliste
Spare parts list
Liste des pièces de rechange
Lista parti di ricambio
Lista de repuestos
Catálogo de peças de substituição

ID HES / FKI27-2 - 8718531004

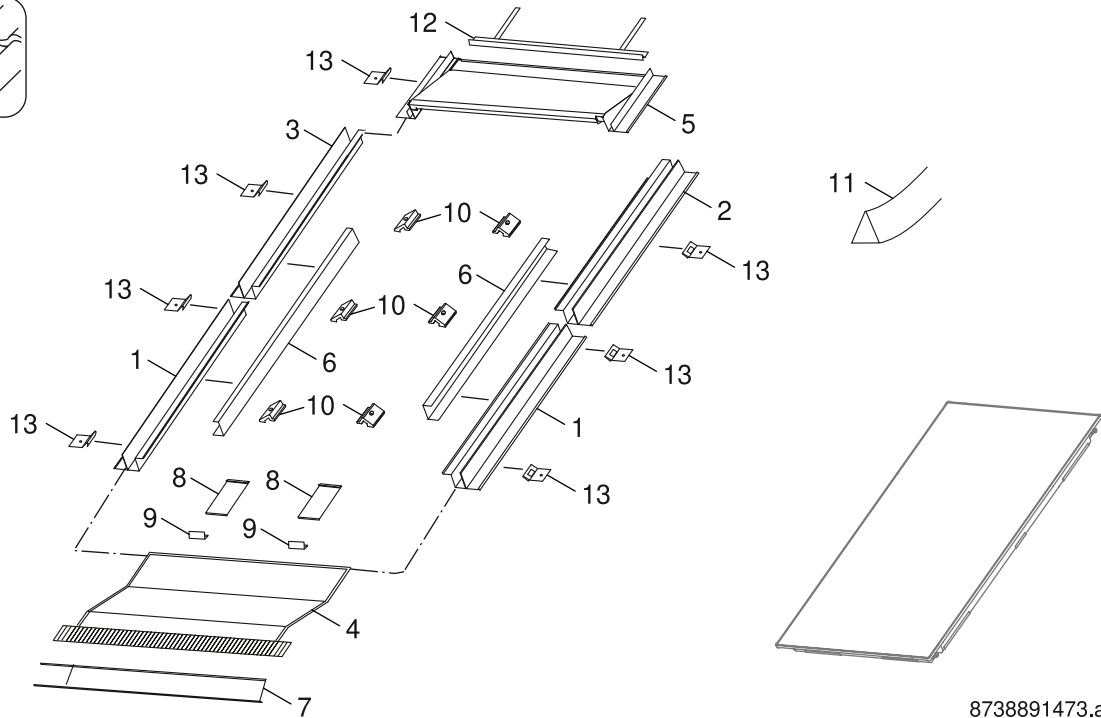
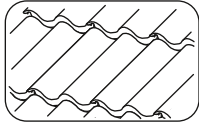

8738891473.ab.RS

	Bestell-Nr.	Bezeichnung	Description	Dénomination	Descrizioni	Descripción	Designação
1	8 718 531 722 0	Eindeckblech rechts unten	Cover bottom right	tôle de protection droite bas	Lamiera di protezione destra sotto	chapa de recubrimiento derecha debajo	Cover bottom right
2	8 718 531 724 0	Eindeckblech rechts oben	Cover right top	tôle de protection droite haut	Lamiera di protezione destra sopra	chapa de recubrimiento derecha arriba	Cover right top
3	8 718 531 725 0	Eindeckblech links oben	Cover left top	tôle de protection gauche haut	Lamiera di protezione sinistra sopra	chapa de recubrimiento izquierda arriba	Cover left top
4	8 718 531 743 0	Eindeckblech unten	Cover bottom	tôle de protection bas	Lamiera di protezione sotto	chapa de recubrimiento debajo	Cover bottom
5	8 718 531 717 0	Eindeckblech oben rechts	Cover top right	tôle de protection haut droite	Lamiera di protezione sopra destra	chapa de recubrimiento arriba derecha	Cover top right
6	8 718 531 748 0	Stützblech senkrecht	Sheet vertical	tôle vertical	Lamierino verticale	chapa vertical	Sheet vertical
7	8 718 531 756 0	Blende	Cover	cache	copertura	diafragma	Cover
8	8 718 531 771 0	Montagehalter	Support	matériel de montage	materiale di montaggio	material de montaje	Support
9	8 718 531 772 0	Abrutschsicherung	Support Slipping safty	Dispositif anti-glisement	scivolo	Tope	Support Slipping safty
10	8 718 531 773 0	Montagehalter seitlich	Support side	Support latéral	materiale di montaggio laterale	material de montaje lateral	Support side
11	8 718 223 904 0	Dichtband dreieckig	Sealing band	ruban isolant	Nastro di tenuta	Cinta aislante	Sealing band
12	8 748 511 075 0	Schiene	Bar	Barre	Telaio	Respaldo	Caixilho
13	8 748 511 055 0	Halter (6x)	support (6x)	PATTE FIXATION KIT MONT CAPTEUR (6x)	Supporto (6x)	Soporte de fijación (6x)	Suporte (6x)

Ersatzteilliste
Spare parts list
Liste des pièces de rechange
Lista parti di ricambio
Lista de repuestos
Catálogo de peças de substituição

ID HEW - 8718532843

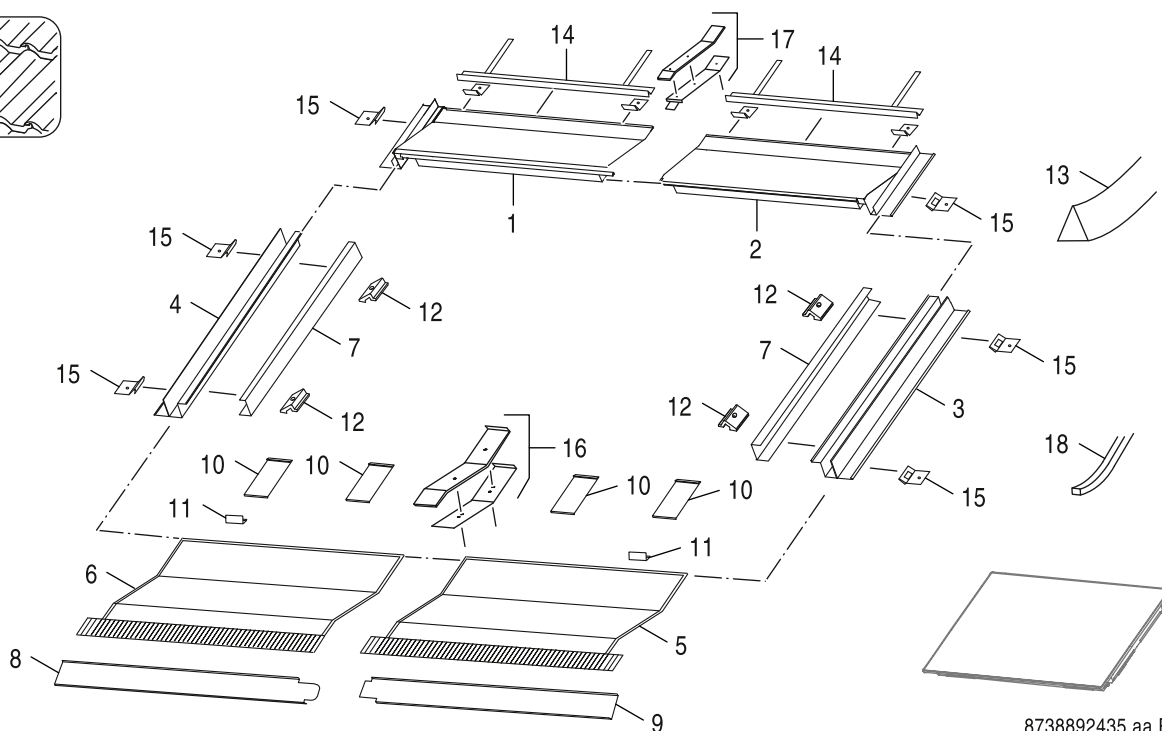
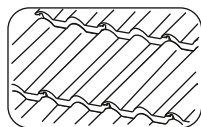

8738892435.aa.RO

	Bestell-Nr.	Bezeichnung	Description	Dénomination	Descrizioni	Descripción	Designação
1	8 718 533 319 0	Eindeckblech oben links	Cover top left	tôle de recouvrement haut gauche	lamiera di copertura sopra sinistra	chapa de recubrimiento arriba izquierda	Cover top left
2	8 718 533 320 0	Eindeckblech oben rechts	Cover top right	tôle de recouvrement haut droite	lamiera di copertura sopra destra	chapa de recubrimiento arriba derecha	Cover top right
3	8 718 531 724 0	Eindeckblech rechts oben	Cover right top	tôle de protection droite haut	Lamiera di protezione destra sopra	chapa de recubrimiento derecha arriba	Cover right top
4	8 718 531 725 0	Eindeckblech links oben	Cover left top	tôle de protection gauche haut	Lamiera di protezione sinistra sopra	chapa de recubrimiento izquierda arriba	Cover left top
5	8 718 533 326 0	Eindeckblech unten rechts	Cover bottom right	tôle de recouvrement bas droite	lamiera di copertura sotto destra	chapa de recubrimiento debajo derecha	Cover bottom right
6	8 718 533 325 0	Eindeckblech unten links	Cover bottom left	tôle de recouvrement bas gauche	lamiera di copertura sotto sinistra	chapa de recubrimiento debajo izquierda	Cover bottom left
7	8 718 531 749 0	Stützblech waagerecht	Sheet horizontal	tôle horizontal	Lamierino orizzontale	chapa horizontal	Sheet horizontal
8	8 718 533 336 0	Blende links	cover panel links	tôle de recouvrement links	pannello di copertura links	chapa de recubrimiento links	cover panel links
9	8 718 533 337 0	Blende rechts	cover panel rechts	tôle de recouvrement rechts	pannello di copertura rechts	chapa de recubrimiento rechts	cover panel rechts
10	8 718 531 771 0	Montagehalter	Support	matériel de montage	materiale di montaggio	material de montaje	Support
11	8 718 531 772 0	Abbrutschsicherung	Support Slipping safty	Dispositif anti-glissement	scivolo	Tope	Support Slipping safty
12	8 718 531 773 0	Montagehalter seitlich	Support side	Support latéral	materiale di montaggio laterale	material de montaje lateral	Support side
13	8 718 223 904 0	Dichtband dreieckig	Sealing band	ruban isolant	Nastro di tenuta	Cinta aislante	Sealing band
14	8 748 511 075 0	Schiene	Bar	Barre	Telaio	Respaldo	Caixilho
15	8 748 511 055 0	Halter (6x)	support (6x)	PATTE FIXATION KIT MONT CAPTEUR (6x)	Supporto (6x)	Soporte de fijación (6x)	Suporte (6x)
16	8 718 531 765 0	Verbinder unten	Connector bottom	kit de raccordement bas	Set di collegamento sotto	set conector debajo	Connector bottom
17	8 718 533 343 0	Verbinder oben	connector set top	kit de raccordement haut	Set di collegamento sopra	set conector arriba	connector set top
18	6 304 637 5	Dichtband Hannoband 10x10x6300 verp	Tape Hannoband 10x10x6300	Bande d'étanchéité p/tuiles creuses	Guarnizione Hannoband 10x10x6300	junta Hannoband 10x10x6300	vedação Hannoband 10x10x6300

Ersatzteilliste
Spare parts list
Liste des pièces de rechange
Lista parti di ricambio
Lista de repuestos
Catálogo de peças de substituição

ID PZES / FK13-2 - 8718530980

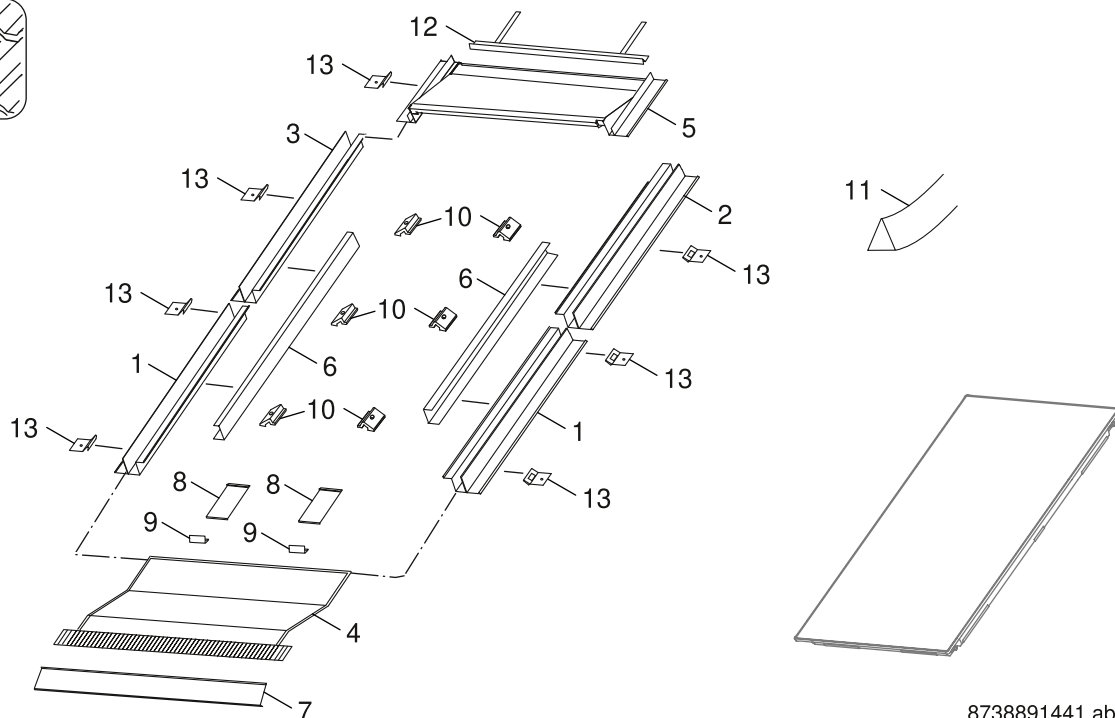
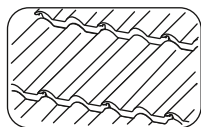

8738891441.ab.RS

	Bestell-Nr.	Bezeichnung	Description	Dénomination	Descrizioni	Descripción	Designação
1	8 718 531 726 0	Eindeckblech rechts unten	Cover right bottom	tôle de protection droite bas	Lamiera di protezione destra sotto	chapa de recubrimiento derecha debajo	Cover right bottom
2	8 718 531 728 0	Eindeckblech rechts oben	Cover right top	tôle de protection droite haut	Lamiera di protezione destra sopra	chapa de recubrimiento derecha arriba	Cover right top
3	8 718 531 729 0	Eindeckblech links oben	Cover left top	tôle de protection gauche haut	Lamiera di protezione sinistra sopra	chapa de recubrimiento izquierda arriba	Cover left top
4	8 718 531 742 0	Eindeckblech unten	Cover bottom	tôle de protection bas	Lamiera di protezione sotto	chapa de recubrimiento debajo	Cover bottom
5	8 718 531 716 0	Eindeckblech oben links	Cover top left	Tôle de couverture supérieure, milieu	Lamiera di copertura sopra sinistra	chapa de recubrimiento arriba izquierda	Cover top left
6	8 718 531 748 0	Stützblech senkrecht	Sheet vertical	tôle vertical	Lamierino verticale	chapa vertical	Sheet vertical
7	8 718 531 756 0	Blende	Cover	cache	copertura	diafragma	Cover
8	8 718 531 771 0	Montagehalter	Support	matériel de montage	materiale di montaggio	material de montaje	Support
9	8 718 531 772 0	Abrutschsicherung	Support Slipping safty	Dispositif anti-glisement	scivolo	Tope	Support Slipping safty
10	8 718 531 773 0	Montagehalter seitlich	Support side	Support latéral	materiale di montaggio laterale	material de montaje lateral	Support side
11	8 718 223 904 0	Dichtband dreieckig	Sealing band	ruban isolant	Nastro di tenuta	Cinta aislante	Sealing band
12	8 748 511 075 0	Schiene	Bar	Barre	Telaio	Respaldo	Caixilho
13	8 748 511 055 0	Halter (6x)	support (6x)	PATTE FIXATION KIT MONT CAPTEUR (6x)	Supporto (6x)	Soporte de fijación (6x)	Suporte (6x)

Ersatzteilliste
Spare parts list
Liste des pièces de rechange
Lista parti di ricambio
Lista de repuestos
Catálogo de peças de substituição

ID SSES / FK15-2 - 8718530992

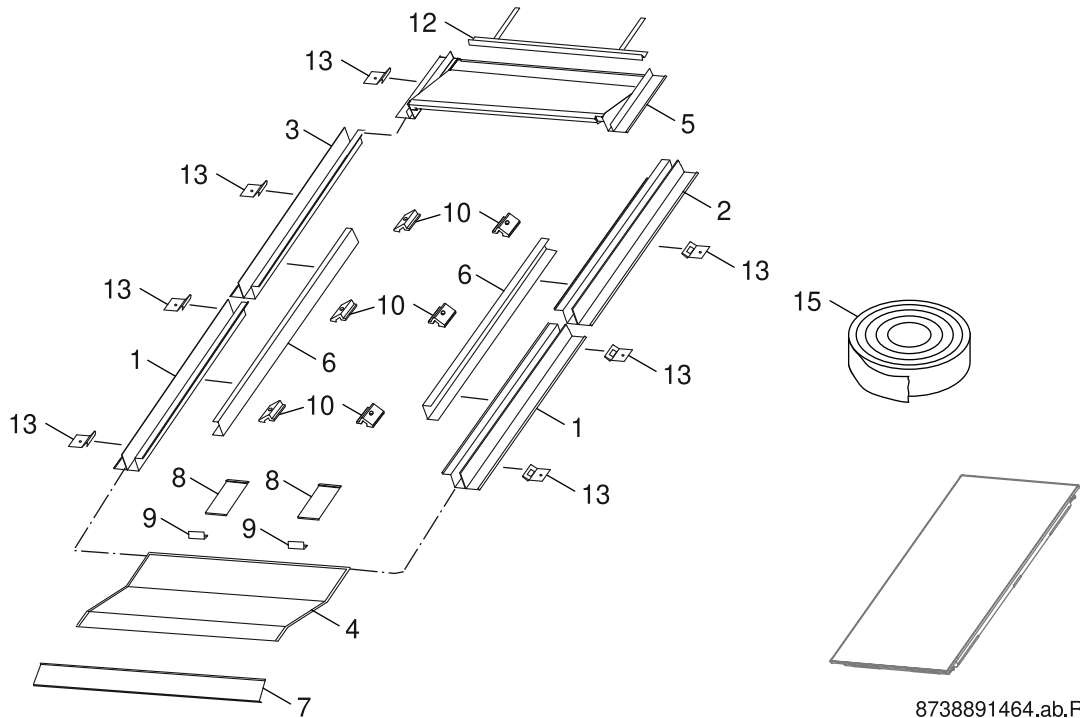
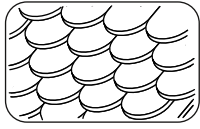

8738891464.ab.RS

	Bestell-Nr.	Bezeichnung	Description	Dénomination	Descrizioni	Descripción	Designação
1	8 718 531 726 0	Eindeckblech rechts unten	Cover right bottom	tôle de protection droite bas	Lamiera di protezione destra sotto	chapa de recubrimiento derecha debajo	Cover right bottom
2	8 718 531 728 0	Eindeckblech rechts oben	Cover right top	tôle de protection droite haut	Lamiera di protezione destra sopra	chapa de recubrimiento derecha arriba	Cover right top
3	8 718 531 729 0	Eindeckblech links oben	Cover left top	tôle de protection gauche haut	Lamiera di protezione sinistra sopra	chapa de recubrimiento izquierda arriba	Cover left top
4	8 718 531 744 0	Eindeckblech unten	Cover bottom	tôle de protection bas	Lamiera di protezione sotto	chapa de recubrimiento debajo	Cover bottom
5	8 718 531 716 0	Eindeckblech oben links	Cover top left	Tôle de couverture supérieure, milieu	Lamiera di copertura sopra sinistra	chapa de recubrimiento arriba izquierda	Cover top left
6	8 718 531 748 0	Stützblech senkrecht	Sheet vertical	tôle vertical	Lamierino verticale	chapa vertical	Sheet vertical
7	8 718 531 756 0	Blende	Cover	cache	copertura	diafragma	Cover
8	8 718 531 771 0	Montagehalter	Support	matériel de montage	materiale di montaggio	material de montaje	Support
9	8 718 531 772 0	Abrutschsicherung	Support Slipping safty	Dispositif anti-glisement	scivolo	Tope	Support Slipping safty
10	8 718 531 773 0	Montagehalter seitlich	Support side	Support latéral	materiale di montaggio laterale	material de montaje lateral	Support side
12	8 748 511 075 0	Schiene	Bar	Barre	Telaio	Respaldo	Caixilho
13	8 748 511 055 0	Halter (6x)	support (6x)	PATTE FIXATION KIT MONT CAPTEUR (6x)	Supporto (6x)	Soporte de fijación (6x)	Suporte (6x)
15	8 718 223 903 0	Dichtschnur UEB Schiefer	Sealing UEB slate	Cordon d'étanchéité	Cordone ermetizzante	cordón junta	Sealing UEB slate



Bosch Thermotechnik GmbH
Sophienstr. 30-32
D-35576 Wetzlar / Germany