



Ihr Online-Fachhändler für:



- Kostenlose und individuelle Beratung
- Hochwertige Produkte
- Kostenloser und schneller Versand

- TOP Bewertungen
- Exzelerter Kundenservice
- Über 20 Jahre Erfahrung



E-Mail: info@unidomo.de | Tel.: 04621 - 30 60 89 0 | www.unidomo.de

**Einbauanleitung
Mounting instruction
Montagehandleiding
Instructions de montage
Istruzioni di montaggio**

Eckmodul
Corner module
Hoekmodule
Module d'angle
Modulo angolare

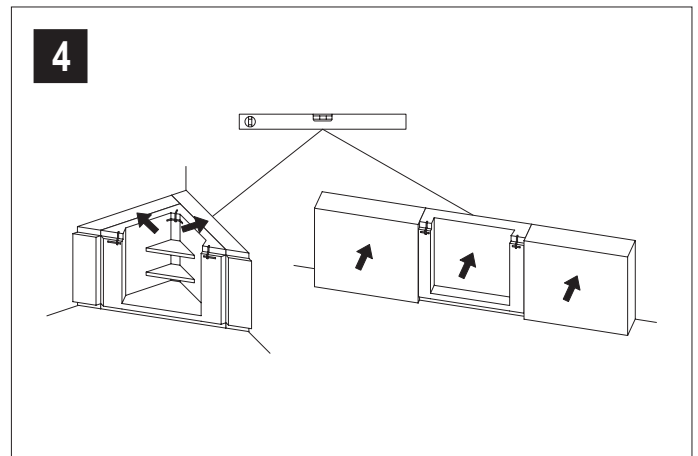
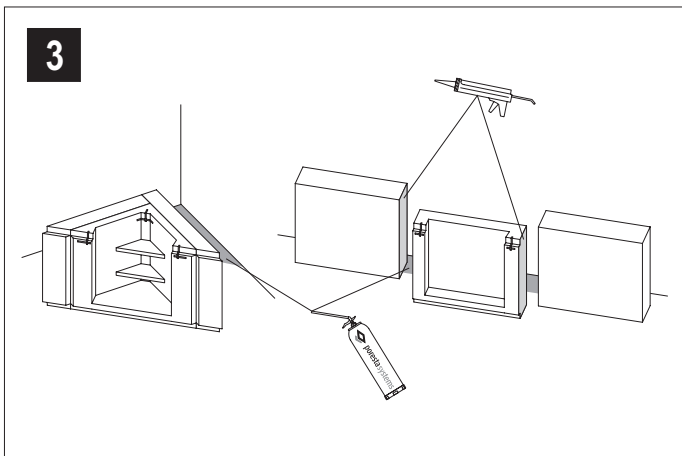
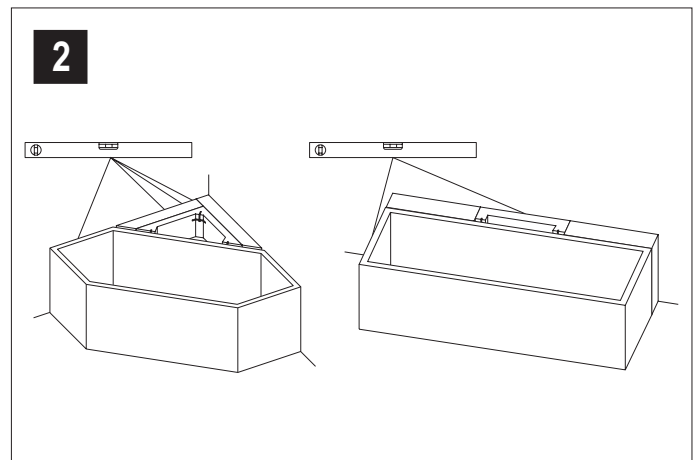
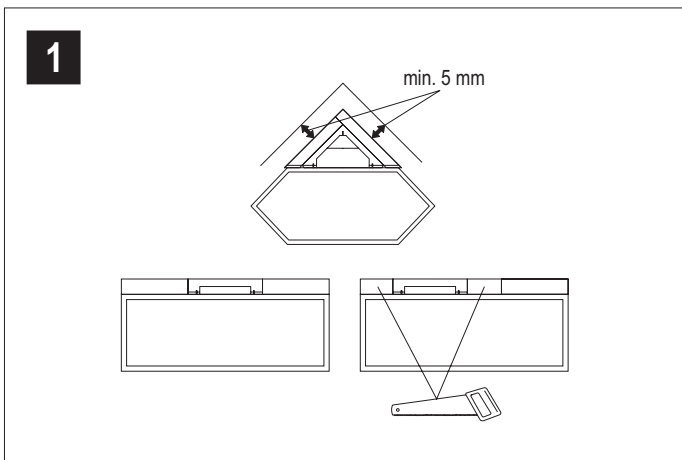
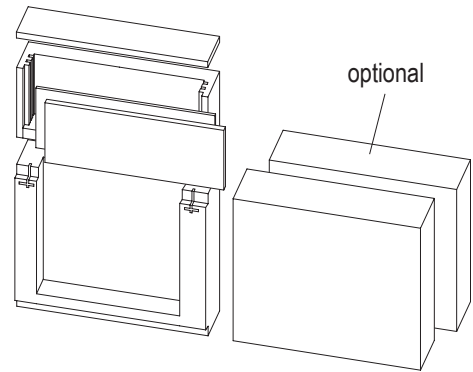
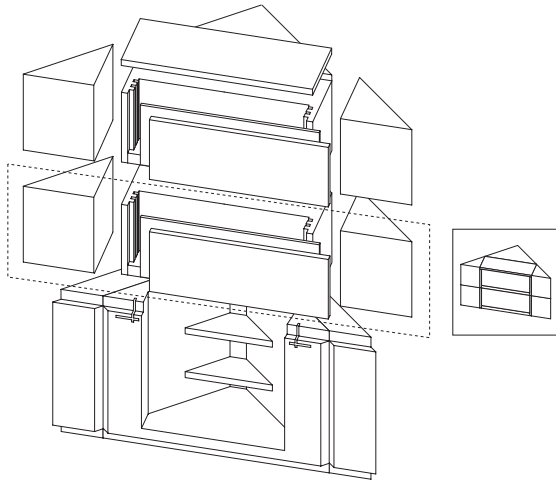

Einbauanleitung
 Mounting instruction
 Montagehandleiding
 Instructions de montage
 Istruzioni di montaggio



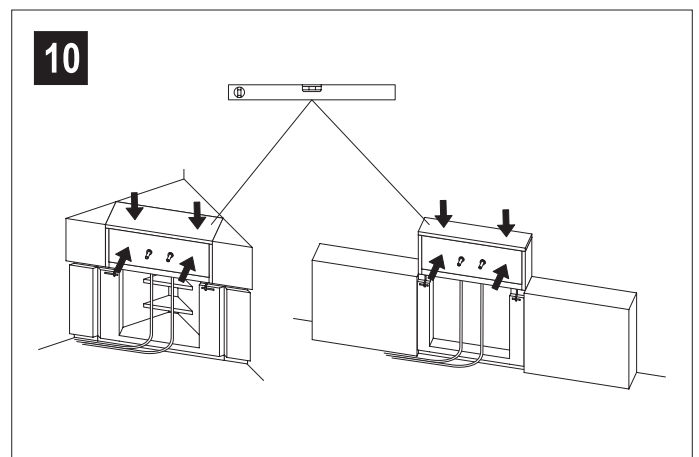
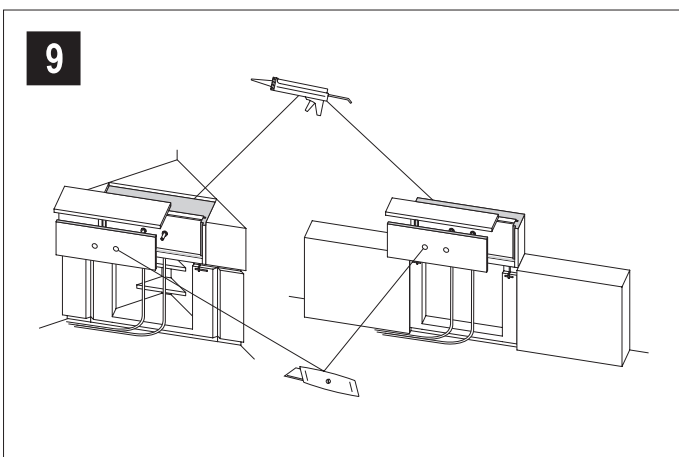
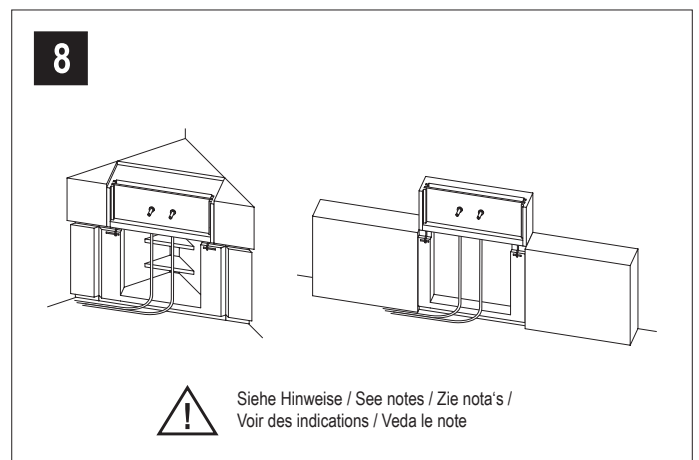
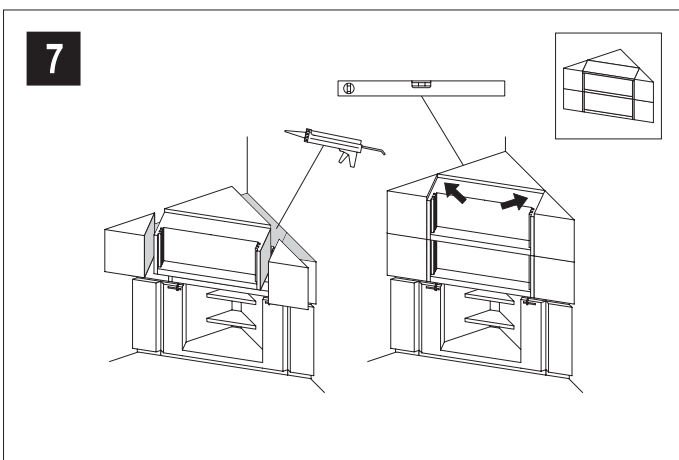
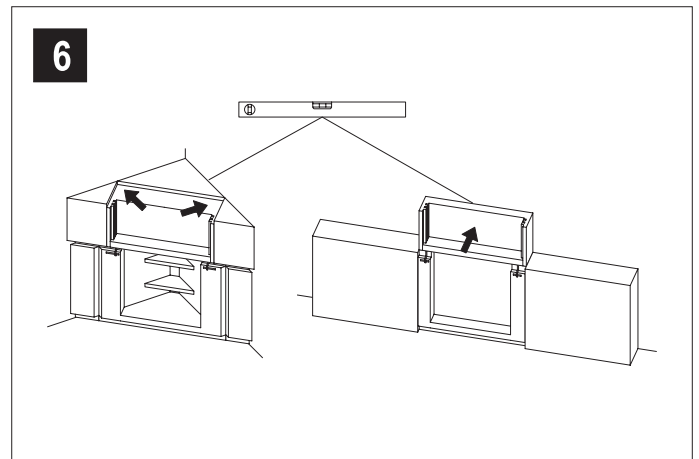
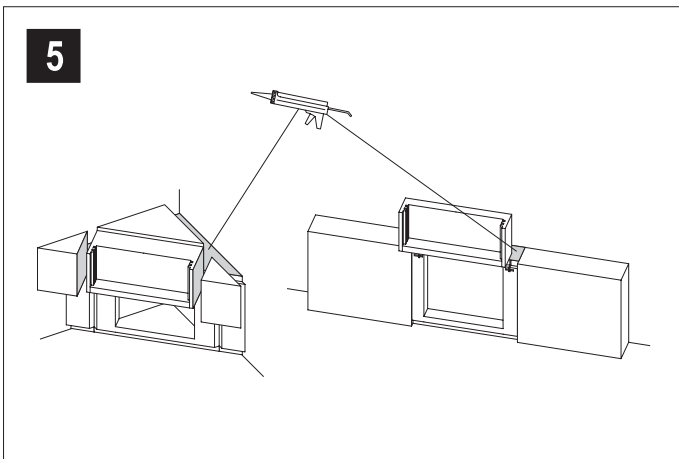

Eckmodul
 Corner module
 Hoekmodule
 Module d'angle
 Modulo angolare



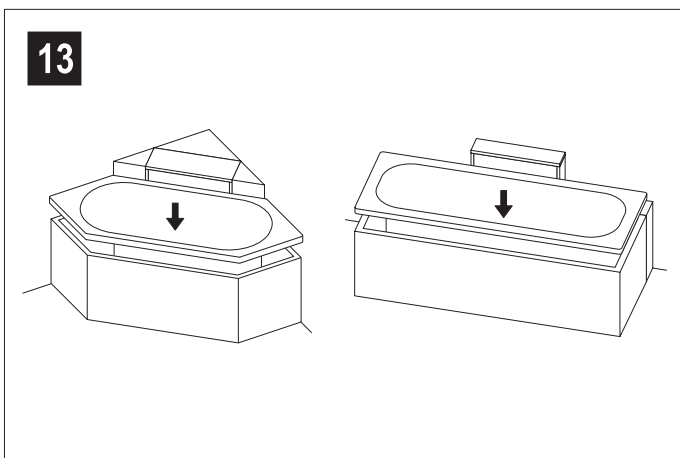
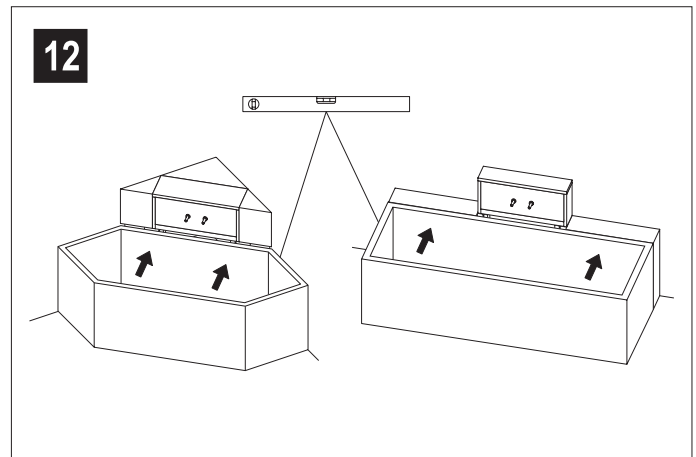
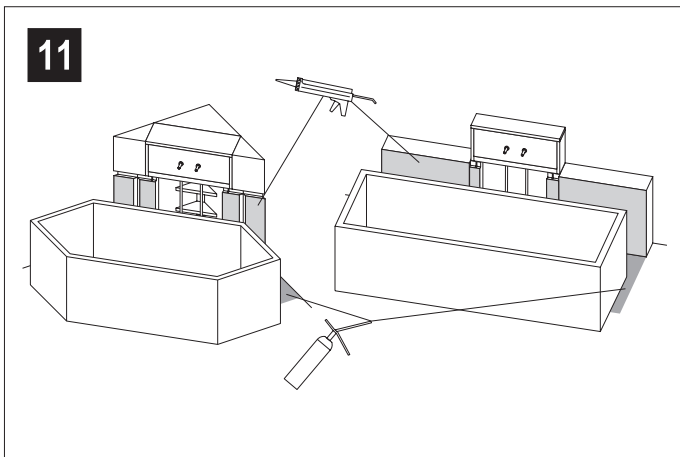



Einbauanleitung
Mounting instruction
Montagehandleiding
Instructions de montage
Istruzioni di montaggio

Eckmodul
 Corner module
 Hoekmodule
 Module d'angle
 Modulo angulare



-  Die Einbaumaße der Wanne, des Wannenträgers und des Eckmoduls sind beim Einbau aufeinander abzustimmen.
-  Die einschlägigen Verarbeitungsrichtlinien aller beteiligten Gewerke sind zu berücksichtigen.
-  Für die Installation der Amaturen ist die beiliegende Einbauanleitung des Herstellers zu beachten.
-  Zündquellen vom Montageschaum fernhalten. Nicht rauchen. Treibgase vor Setzen der Bauelemente gut ablüften lassen.

-  The assembly dimensions of bathtub, bathtub carrier and corner module shall be coordinated during installation.
-  The relevant processing regulations of all trades participating are to be taken into consideration.
-  For the installation of valves and fittings the enclosed mounting instructions of the manufacturer must be adhered to.
-  Keep away ignition sources from PUR foam. Do not smoke. Before placing the structural elements take care to have propellant gases well evacuated.

Einbauanleitung Mounting instruction Montagehandleiding Instructions de montage Istruzioni di montaggio

Eckmodul
Corner module
Hoekmodule
Module d'angle
Modulo angolare

 De inbouwmaten van de kuip, de kuipdragers en de hoekmodule moeten bij de inbouw op elkaar afgestemd worden.

 Voor inbouw en verwerking van alle betrokken onderdelen moeten de betreffende aanwijzingen en richtlijnen worden aangehouden.

 Voor de installatie van de appendages moet de bijliggende montagehandleiding van de fabrikant worden aangehouden.

 Vonken en open vuur uit de buurt van het montageschuim houden. Niet roken. Vóór inbouw van de bouwelementen wachten, tot de ruimte vrij van drijfgassen is.

 Lors de l'installation, les dimensions de montage du bassin, du support de bassin et du module d'angle doivent être ajustées l'une en fonction de l'autre.

 Il faut tenir compte des directives de mise en oeuvre applicables de tous les métiers participant aux travaux.

 En ce qui concerne l'installation de la robinetterie, il faut observer les instructions de montage du fabricant jointes au matériel.

 Les sources d'allumage sont à tenir éloignées de la mousse de montage. Ne pas fumer. Laisser s'évacuer bien les gaz propulseurs avant la pose des éléments de construction.

 All'installazione, le dimensioni di montaggio della vasca, del supporto di vasca e del modulo angolare devono essere adattate l'una in funzione dell'altra.

 I regolamenti di lavorazione rilevanti di tutti i mestieri partecipanti devono essere presi in considerazione.

 Per l'installazione dei rubinetti le istruzioni di montaggio del costruttore devono essere osservate.

 Tenere a distanza sorgenti d'accensione da schiuma di montaggio. Non fumare. Ben evacuare gas propellanti prima di mettere gli elementi costruttivi.

Empfohlenes Zubehör / Recommended accessories /
Aanbevolen toebehoren / Accessoires recommandés /
Accessori raccomandati:

Konstruktionskleber (PU) oder Fliesenkleber (flexibel)
Structural adhesive (PU) or tile adhesive (flexible)

 Constructielijm (PU) of tegellijm (flexibel)
Colle de construction (PU) ou colle à carreaux (flexible)
Collante per costruzioni (PU) o colla per piastrelle (flessibile)

Wannenträgermontageschaum

Tub carrier PUR foam

 Montageschuim voor badkuipdragers
Mousse de montage pour support de bassin
Schiuma di montaggio supporto vasca