



Ihr Online-Fachhändler für:



- Kostenlose und individuelle Beratung
- Hochwertige Produkte
- Kostenloser und schneller Versand

- TOP Bewertungen
- Exzelerter Kundenservice
- Über 20 Jahre Erfahrung



E-Mail: info@unidomo.de | Tel.: 04621 - 30 60 89 0 | www.unidomo.de

**Einbauanleitung
Mounting instruction
Montagehandleiding
Instructions de montage
Istruzioni di montaggio**

Ablagen und Stufen
Rests and steps
Legplank en treden
Tablettes et marches
Portaoggetti e gradini

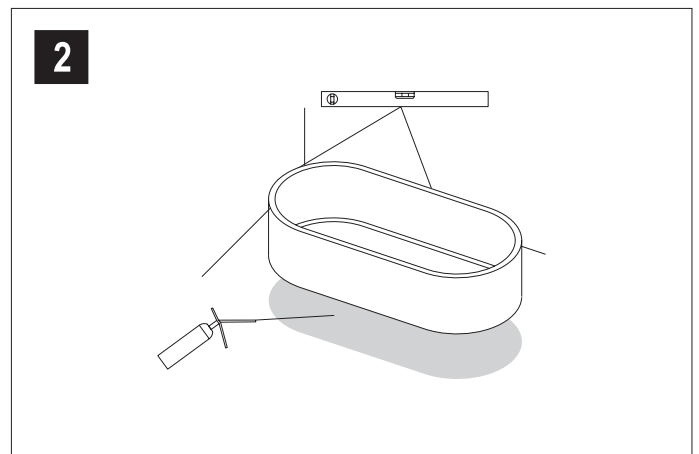
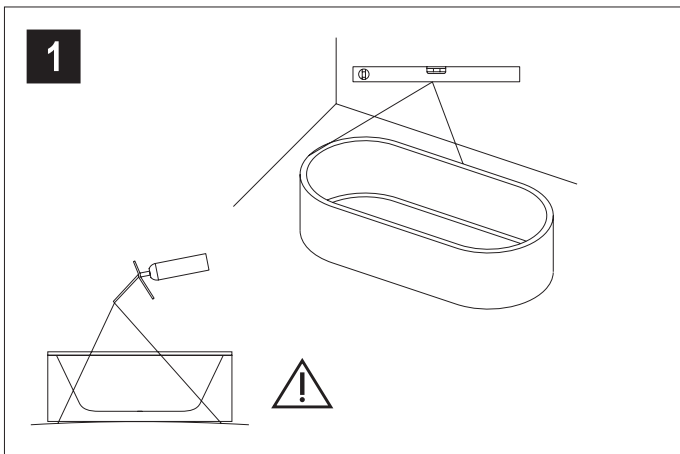
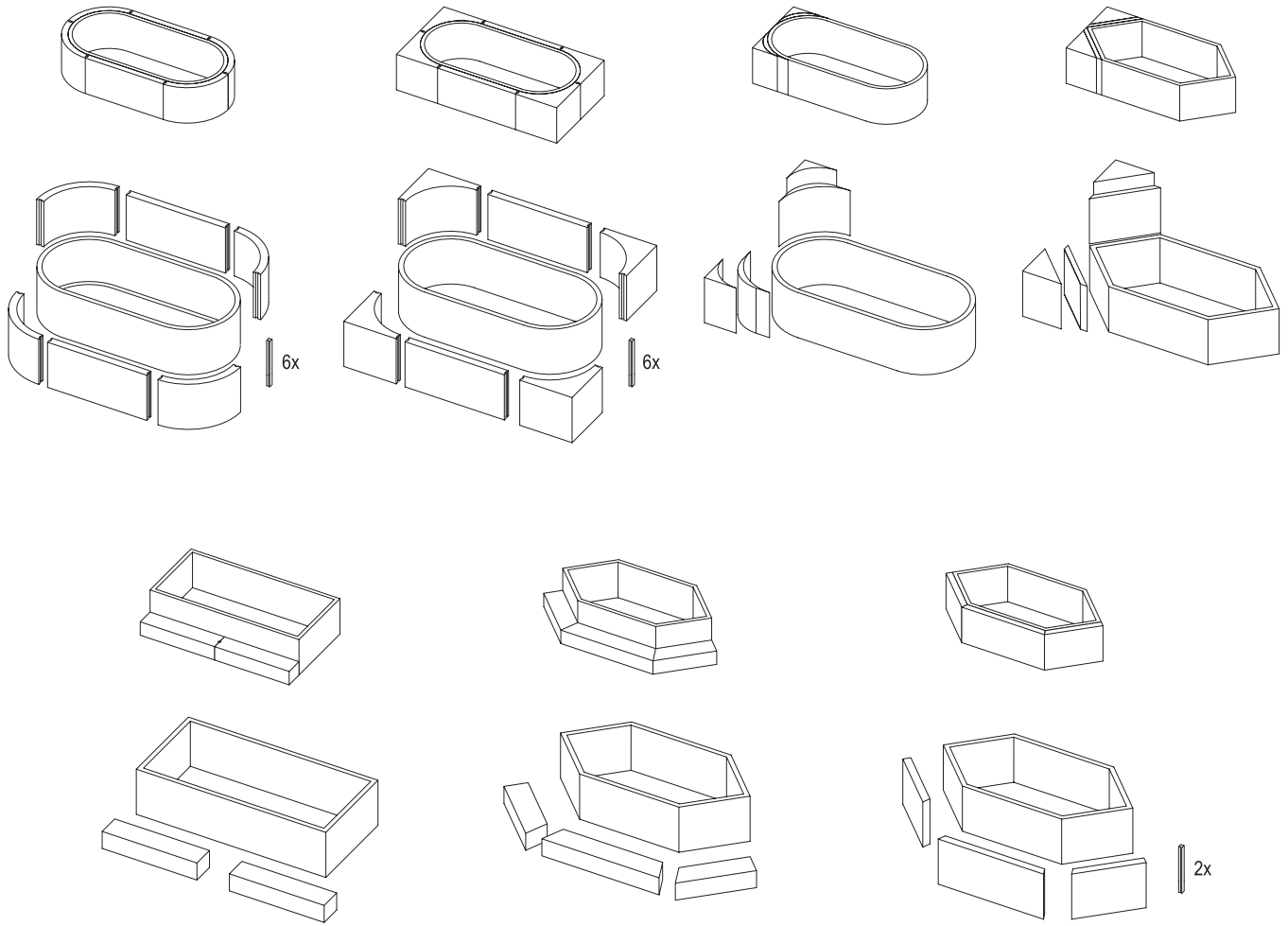

Einbauanleitung
Mounting instruction
Montagehandleiding
Instructions de montage
Istruzioni di montaggio

Ablagen und Stufen
Rests and steps
Legplank en treden
Tablettes et marches
Portaoggetti e gradini

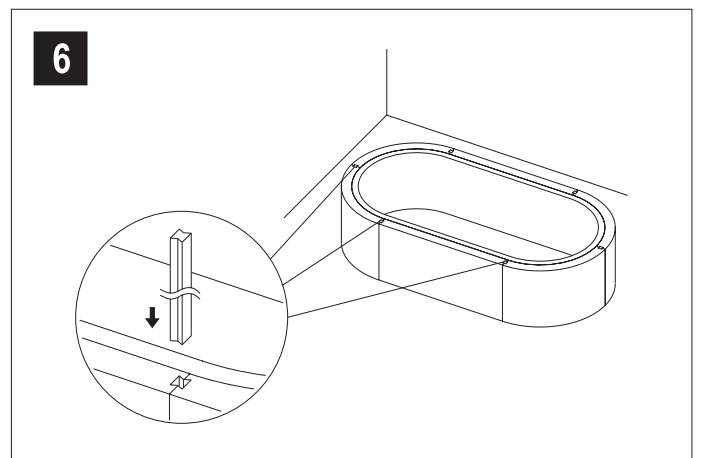
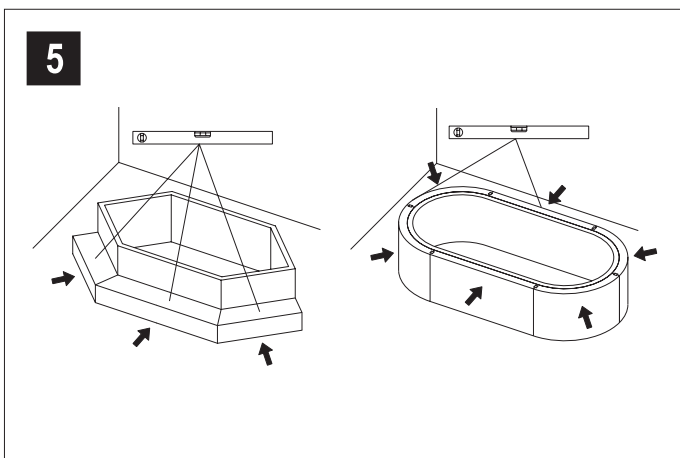
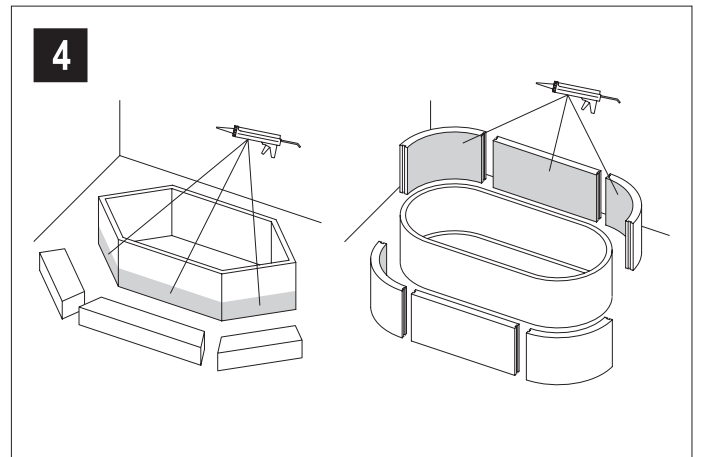
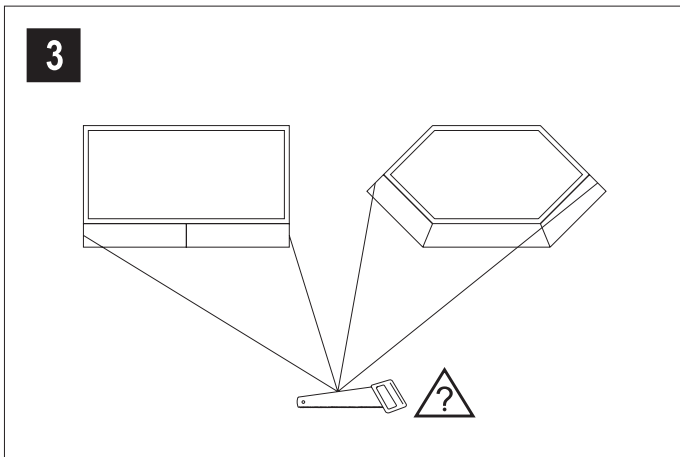

Einbauanleitung

Mounting instruction

Montagehandleiding

Instructions de montage

Istruzioni di montaggio

Ablagen und Stufen
Rests and steps
Legplank en treden
Tablettes et marches
Portaoggetti e gradini

-  Die einschlägigen Verarbeitungsrichtlinien aller beteiligten Gewerke sind zu berücksichtigen.
-  Zündquellen vom Montageschaum fernhalten. Nicht rauchen. Treibgase vor Setzen der Bauelemente gut ablüften lassen.
-  The relevant processing regulations of all trades participating are to be taken into consideration.
-  Keep away ignition sources from PUR foam. Do not smoke. Before placing the structural elements take care to have propellant gases well evacuated.
-  Voor inbouw en verwerking van alle betrokken onderdelen moeten de betreffende aanwijzingen en richtlijnen worden aangehouden.
-  Vonken en open vuur uit de buurt van het montageschuim houden. Niet roken. Vóór inbouw van de bouwelementen wachten, tot de ruimte vrij van drijfgassen is.
-  Il faut tenir compte des directives de mise en oeuvre applicables de tous les métiers participant aux travaux.
-  Les sources d'allumage sont à tenir éloignées de la mousse de montage. Ne pas fumer. Laisser s'évacuer bien les gaz propulseurs avant la pose des éléments de construction.
-  I regolamenti di lavorazione rilevanti di tutti i mestieri partecipanti devono essere presi in considerazione.
-  Tenere a distanza sorgenti d'accensione da schiuma di montaggio. Non fumare. Ben evacuare gas propellanti prima di mettere gli elementi costruttivi.

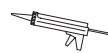

Konstruktionskleber (PU) oder Fliesenkleber (flexibel)
Structural adhesive (PU) or tile adhesive (flexible)
Constructielijm (PU) of tegellijm (flexibel)
Colle de construction (PU) ou colle à carreaux (flexible)
Collante per costruzioni (PU) o colla per piastrelle (flessibile)



Wannenträgermontageschaum
Tub carrier PUR foam
Montageschuim voor badkuipdragers
Mousse de montage pour support de bassin
Schiuma di montaggio supporto vasca