



Ihr Online-Fachhändler für:



- Kostenlose und individuelle Beratung
- Hochwertige Produkte
- Kostenloser und schneller Versand

- TOP Bewertungen
- Exzelerter Kundenservice
- Über 20 Jahre Erfahrung



E-Mail: info@unidomo.de | Tel.: 04621 - 30 60 89 0 | www.unidomo.de

Einbauanleitung
Mounting instruction
Montagehandleiding
Instructions de montage
Istruzioni di montaggio

Poresta® Universalschürze für Stahl- und Acrylbadewannen
 Poresta® Universal skirt for steel and acrylic bathtubs
 Poresta® universele beplating voor stalen en acrylbadkuipen
 Jupe universelle Poresta® pour baignoires en acier et acryliques
 Piastrone universale Poresta® per vasche da bagno in acciaio ed acriliche

Set A
 Art.-Nr.: 17.038.557

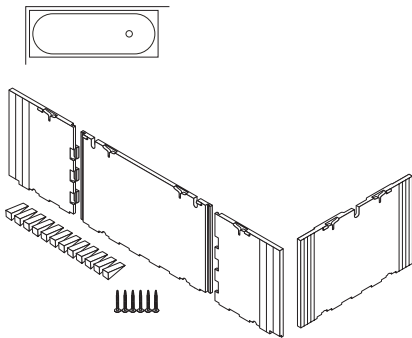

Set B
 Art.-Nr.: 17.038.558

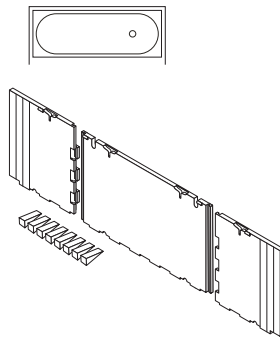

Set C
 Art.-Nr.: 17.038.559

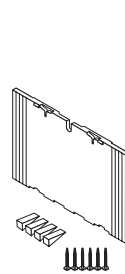

B + 2x C
 Art.Nr.: 17.038.558 (Set B)
 Art.Nr.: 17.038.559 (Set C)

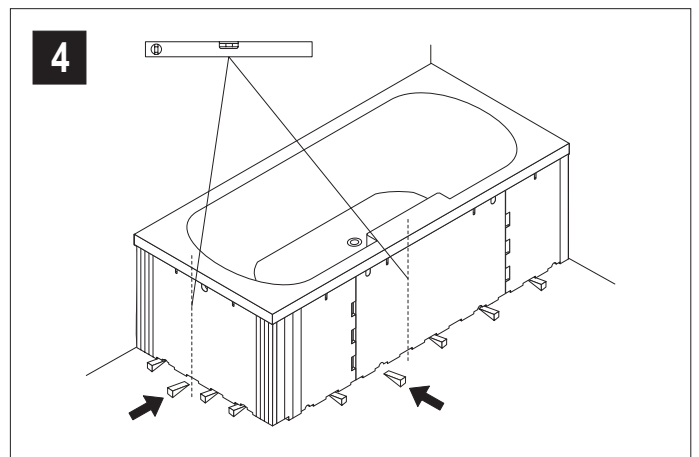
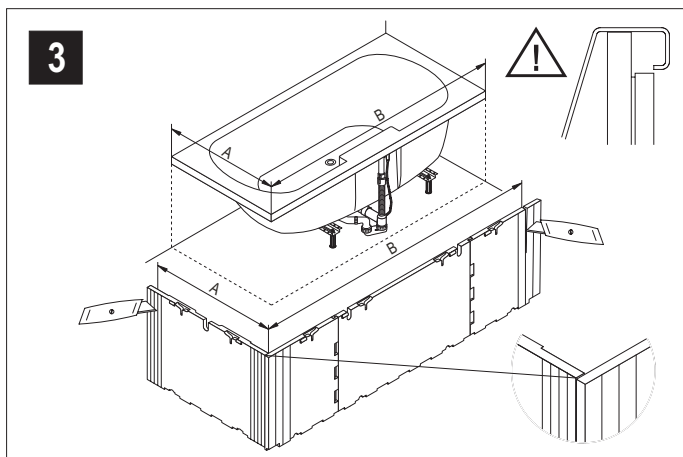
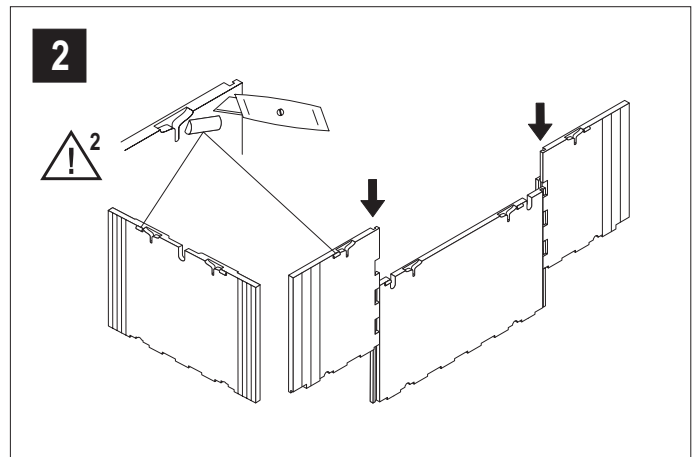
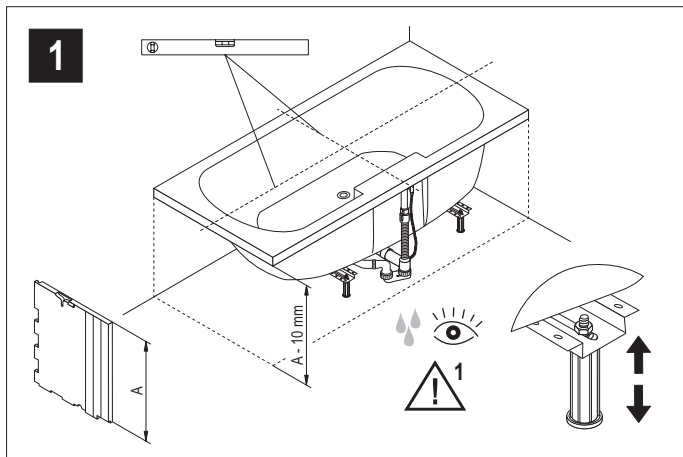
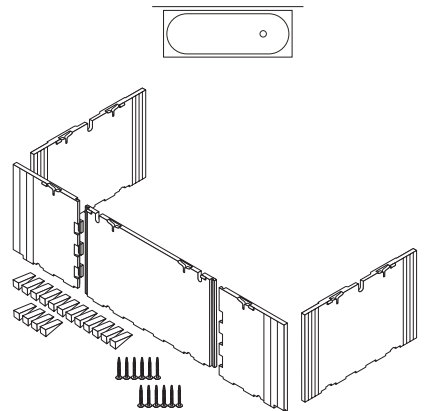

Einbauanleitung
Mounting instruction
Montagehandleiding
Instructions de montage
Istruzioni di montaggio

Poresta® Universalschürze für Stahl- und Acrylbadewannen
Poresta® Universal skirt for steel and acrylic bathtubs
Poresta® universele beplating voor stalen en acrylbadkuipen
Jupe universelle Poresta® pour baignoires en acier et acryliques
Piastrone universale Poresta® per vasche da bagno in acciaio ed acriliche

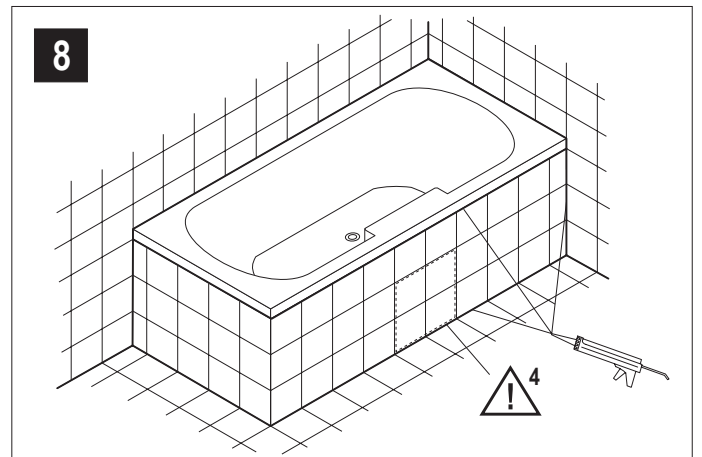
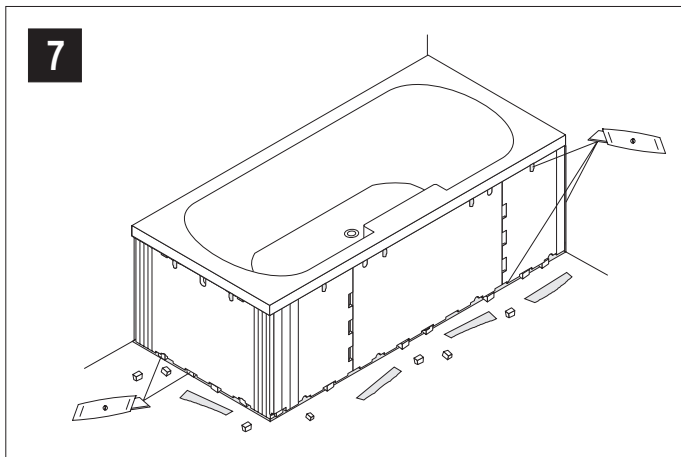
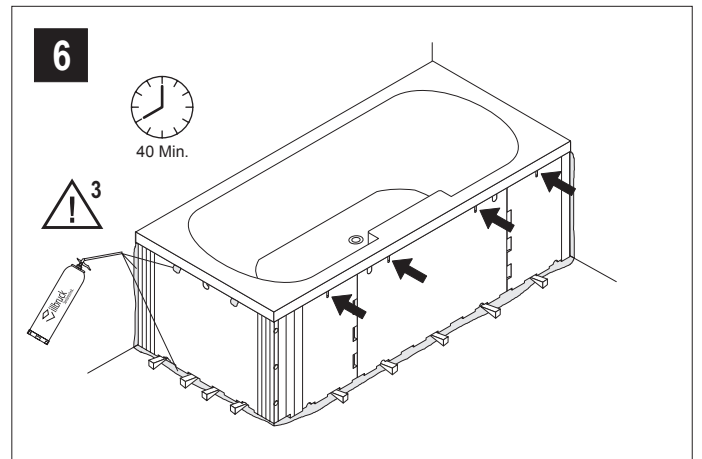
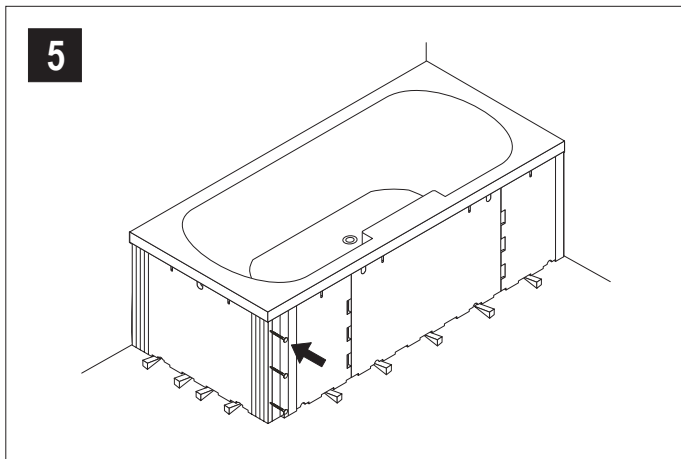

Einbauanleitung

























Mounting instruction

Montagehandleiding

Instructions de montage

Istruzioni di montaggio

Poresta® Universalschürze für Stahl- und Acrylbadewannen
 Poresta® Universal skirt for steel and acrylic bathtubs
 Poresta® universele beplating voor stalen en acrylbadkuipen
 Jupe universelle Poresta® pour baignoires en acier et acryliques
 Piastrone universale Poresta® per vasche da bagno in acciaio ed acriliche

- | | |
|---|---|
| <p> Die einschlägigen Verarbeitungsrichtlinien aller beteiligten Gewerke sind zu berücksichtigen.</p> <p> Für den Einbau der Poresta® Universalschürze muss ein ebener, sauberer, tragfähiger, schwingungsfreier und für die Verklebung mit Poresta® Wannenträger Montageschaum geeigneter Untergrund vorhanden sein.</p> <p> ¹ Nach Installation der Ablaufgarnitur ist eine Dichtigkeitsprüfung durchzuführen.</p> <p> ² Die Abstandhalter gewährleisten bei Stahlbadewannen den korrekten Abstand zum Wannenrand, beim Einbau einer Acrylbadewanne müssen die Abstandhalter entfernt werden.</p> <p> ³ Bei Arbeiten mit Poresta® Wannenträger Montageschaum sind die Verarbeitungshinweise zu beachten. Zündquellen vom Montageschaum fernhalten und nicht rauchen. Treibgase gut ablüften lassen.</p> <p> ⁴ Im Bereich der Ablaufgarnitur sind Revisionsfliesen zu setzen.</p> <p> The relevant working guidelines of all the trades involved shall be observed.</p> <p> For installation of the Poresta® universal skirt, a flat, clean, firm and vibration-less substrate suitable for cementing with Poresta® supporting frame mounting foam is required.</p> <p> ¹ After the installation of the drain fitting, a leak test has to be carried out.</p> <p> ² For steel bathtubs, the spacers ensure the correct distance from the bathtub rim, when installing an acrylic bathtub the spacers have to be removed.</p> <p> ³ When working with Poresta® supporting frame mounting foam, the working instructions shall be observed. Keep mounting foam away from ignition sources and do not smoke. Thoroughly ventilate propellants.</p> <p> ⁴ In the area of the outlet fitting inspection tiles are to be installed.</p> | <p> Houd rekening met de verwerkingsrichtlijnen van alle betrokken leveranciers.</p> <p> Voor de montage van de Poresta® universele beplating moet een vlakke, schone en dragende, trillingsvrije ondergrond aanwezig zijn, die geschikt is voor het gebruik van Poresta® badkuipdragermontageschuim.</p> <p> ¹ Controleer na installatie van de afvoergarnituur of deze niet lekt.</p> <p> ² De afstandshouders zorgen bij stalen badkuipen voor de juiste afstand tot de badkuiprand, bij montage van een acrylbadkuip moeten de afstandshouders worden verwijderd.</p> <p> ³ Let bij het werken met Poresta® badkuipdragermontageschuim op de verwerkingsrichtlijnen. Houd ontstekingsbronnen verwijderd van het montageschuim en rook niet! Laat drijfgassen goed ontsnappen.</p> <p> ⁴ In de buurt van de afvoergarnituur dient een serviceluis te worden geplaatst.</p> <p> Les instructions correspondantes de mise en oeuvre de tous les métiers participants sont à respecter.</p> <p> Pour le montage de la jupe universelle Poresta®, il faut avoir une surface plane, propre, stable, exempte de vibrations et appropriée au collage avec de la mousse de montage pour supports de baignoires Poresta®.</p> <p> ¹ Après installation de la garniture d'écoulement, procéder à un contrôle de l'étanchéité.</p> <p> ² Les écarteurs assurent la distance correcte au bord de la baignoire dans le cas des baignoires en acier, alors que les écarteurs doivent être enlevés s'il s'agit d'une baignoire acrylique.</p> <p> ³ Lors de travaux avec de la mousse de montage pour supports de baignoires Poresta®, il faut respecter les instructions de mise en oeuvre. Éviter la présence de sources inflammables à proximité de la mousse de montage et ne pas fumer. Laisser s'évacuer les gaz propulseurs.</p> <p> ⁴ Poser des carreaux permettant des travaux de révision dans la zone de la garniture d'écoulement.</p> |
|---|---|

Einbauanleitung

Mounting instruction

Montagehandleiding

Instructions de montage

Istruzioni di montaggio

Poresta® Universalschürze für Stahl- und Acrylbadewannen
Poresta® Universal skirt for steel and acrylic bathtubs
Poresta® universele beplating voor stalen en acrylbadkuipen
Jupe universelle Poresta® pour baignoires en acier et acryliques
Piastrone universale Poresta® per vasche da bagno in acciaio ed acriliche



Si deve osservare le istruzioni corrispondenti di lavorazione di tutti i mestieri partecipanti.



Per il montaggio del piastrone universale Poresta® è necessario di avere una superficie piana, pulita, stabile, esente da vibrazioni ed appropriata all'incollatura con schiuma di montaggio Poresta® per sopporti di vasca.



1 Dopo l'installazione dell'elemento di scarico si deve procedere ad una prova di tenuta.



2 I distanziatori assicurano la distanza corretta al bordo della vasca in caso di vasche in acciaio; se si tratta di una vasca acrilica i distanziatori devono essere rimossi.



3 Per lavori con schiuma di montaggio Poresta® per sopporti di vasca, si deve osservare le istruzioni di lavorazione.

Evitare la presenza di fonti infiammabili in prossimità della schiuma di montaggio e non fumare. Lasciar evaporare i gas propellenti.



4 Posare piastrelle permettendo lavori di revisione nella zona dell'elemento di scarico.

Empfohlenes Zubehör / Recommended accessories /
Aanbevolen toebehoren / Accessoires recommandés /
Accessori raccomandati:



Poresta® Wannenträger Montageschaum / Supporting
frame mounting foam / Badkuipdragermontageschuim /
Mousse de montage pour supports de baignoires /
Schiuma di montaggio per sopporti di vasca



Silikon / Silicone / Siliconen / Silicone / Silicone