



---

## Ihr Online-Fachhändler für:

---



- Kostenlose und individuelle Beratung
- Hochwertige Produkte
- Kostenloser und schneller Versand

- TOP Bewertungen
- Exzelerter Kundenservice
- Über 20 Jahre Erfahrung



**E-Mail: [info@unidomo.de](mailto:info@unidomo.de) | Tel.: 04621 - 30 60 89 0 | [www.unidomo.de](http://www.unidomo.de)**

**Einbauanleitung**  
**Mounting instruction**  
**Instructions de montage**  
**Instrucciones de instalación**

Poresta® SELECT Duschelemente  
Poresta® SELECT Shower elements  
Poresta® SELECT Douche-elementen  
Poresta® SELECT Éléments de douche  
Poresta® SELECT Elementi doccia

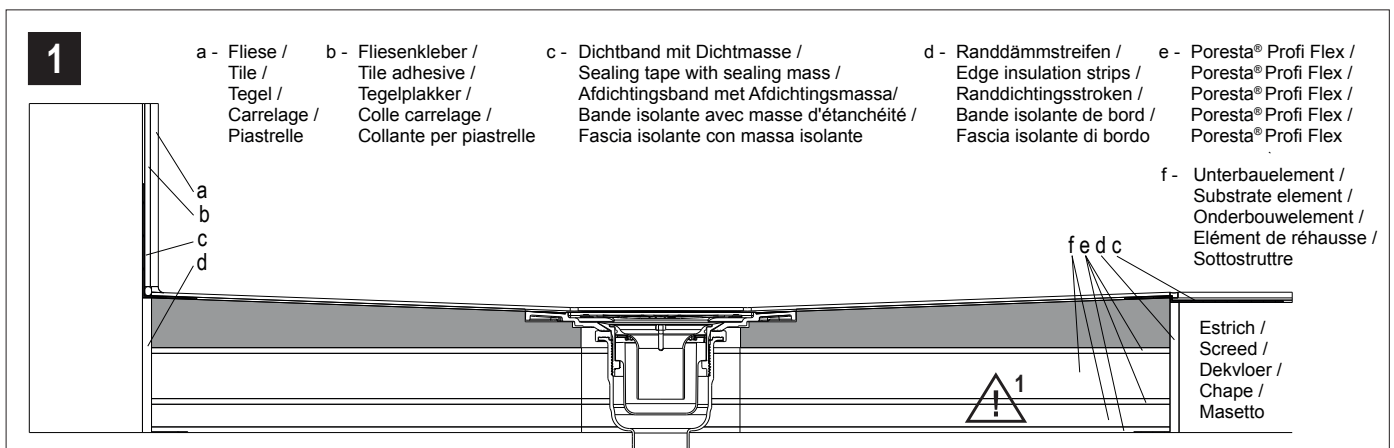
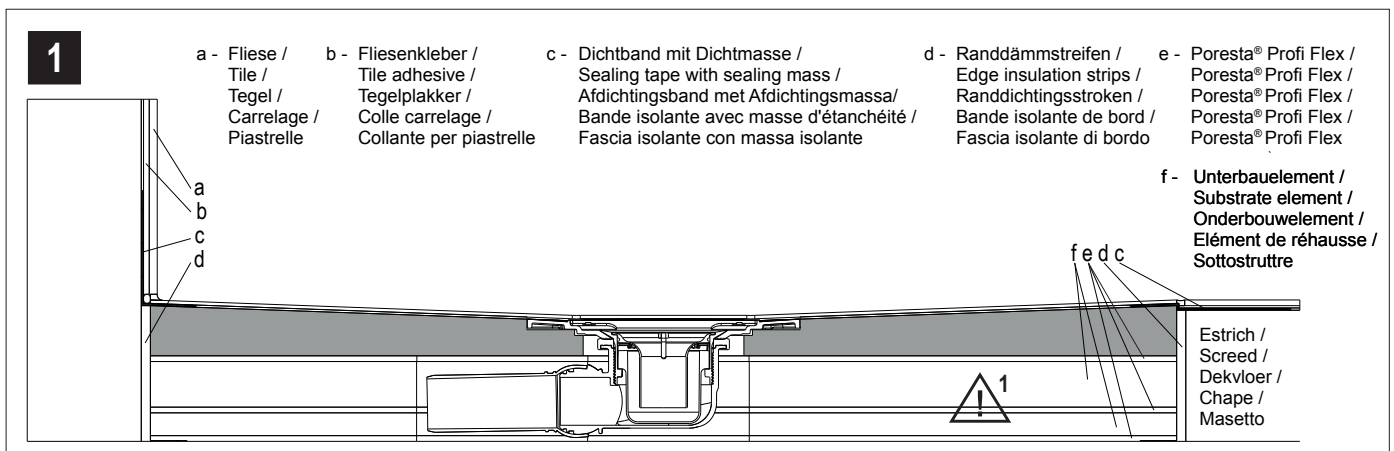
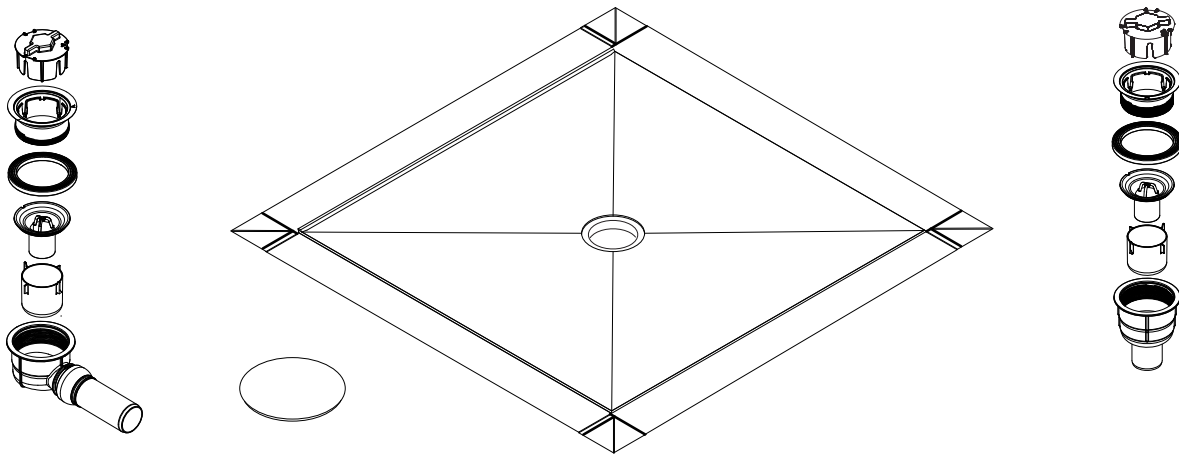

**Einbauanleitung**  
**Mounting instruction**  
**Instructions de montage**  
**Instrucciones de instalación**

Poresta® SELECT Duschelemente  
Poresta® SELECT Shower elements  
Poresta® SELECT Douche-elementen  
Poresta® SELECT Éléments de douche  
Poresta® SELECT Elementi doccia

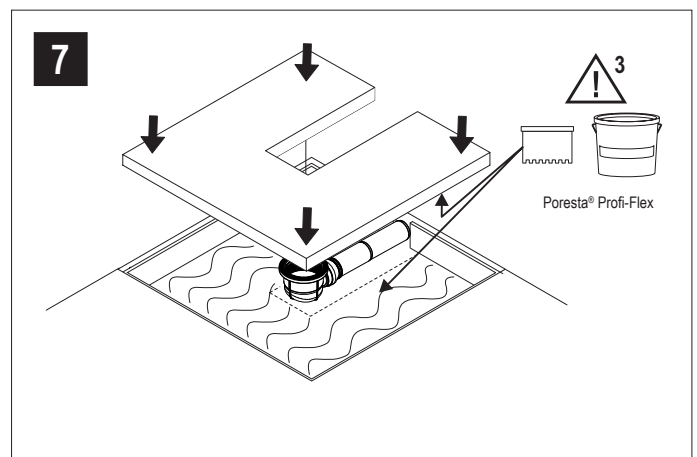
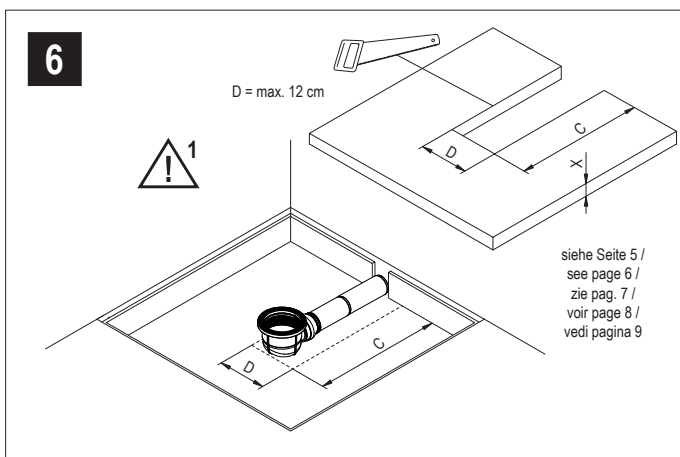
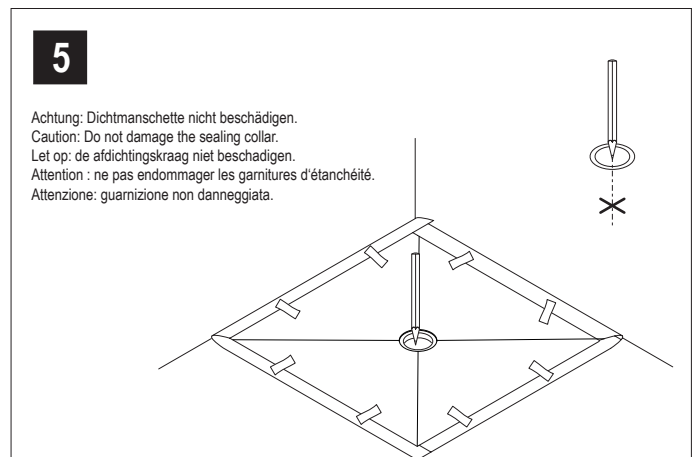
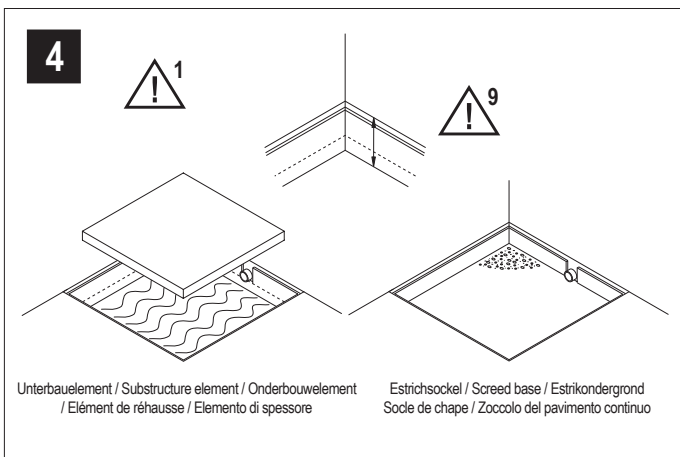
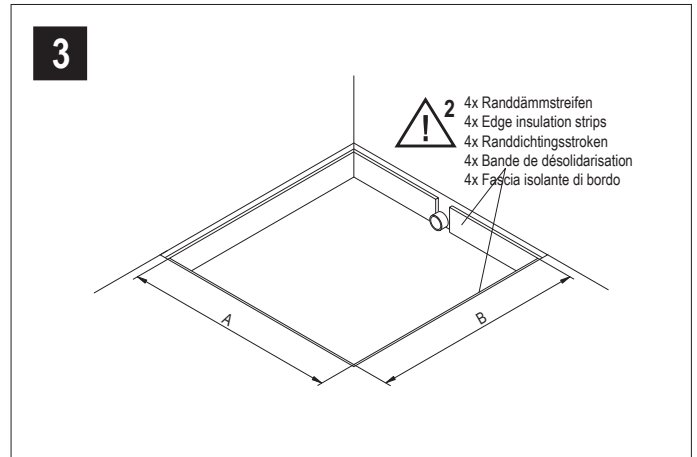
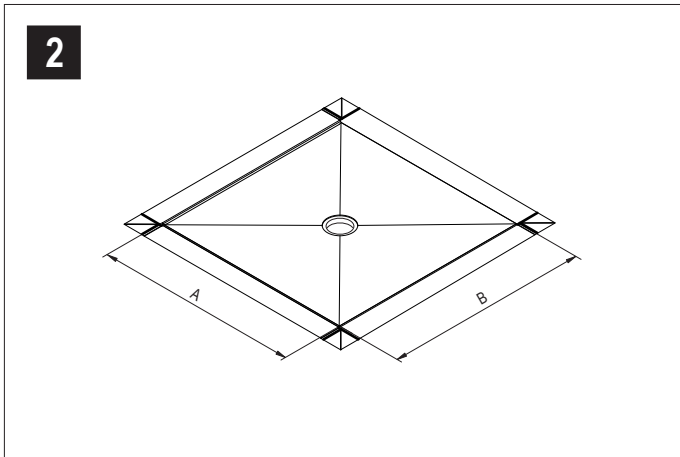

**Einbauanleitung**  
**Mounting instruction**  
**Instructions de montage**  
**Instrucciones de instalación**

Poresta® SELECT Duschelemente  
 Poresta® SELECT Shower elements  
 Poresta® SELECT Douche-elementen  
 Poresta® SELECT Éléments de douche  
 Poresta® SELECT Elementi doccia

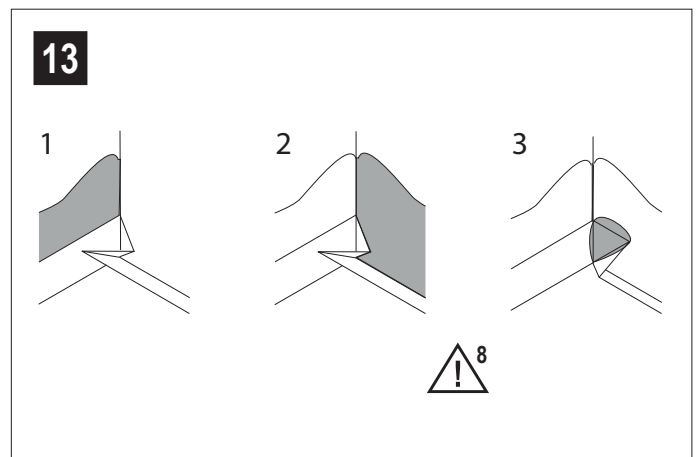
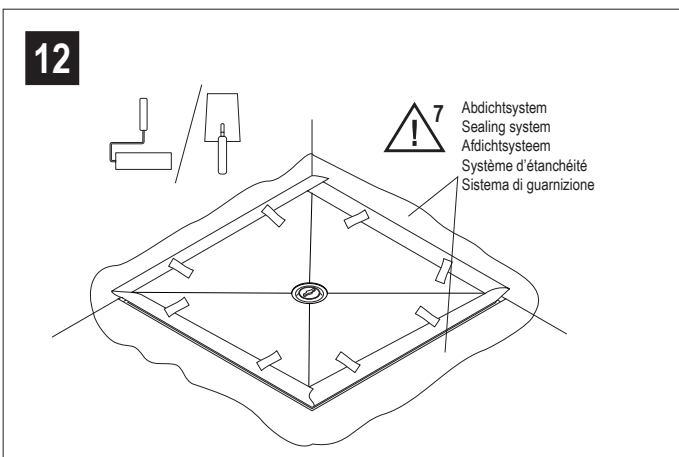
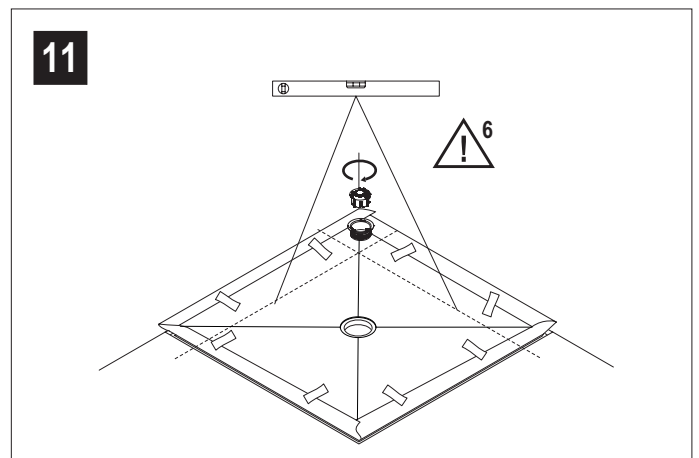
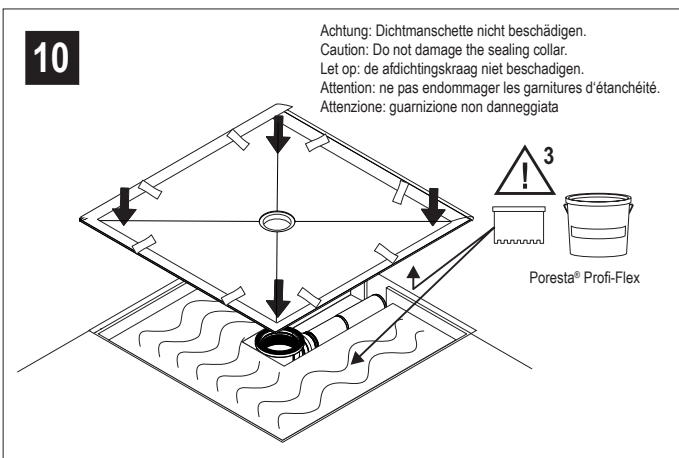
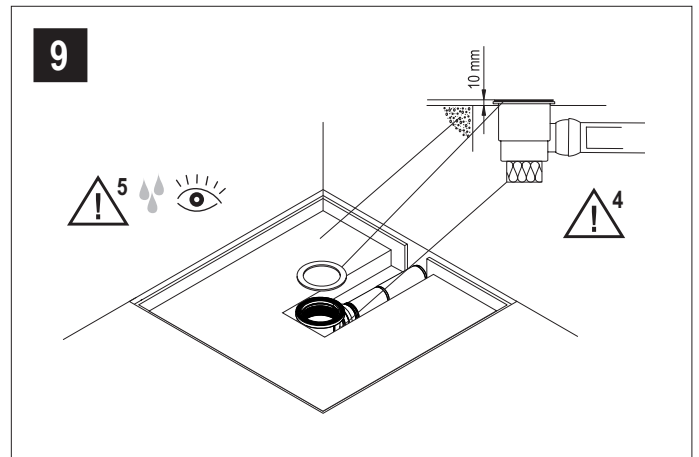
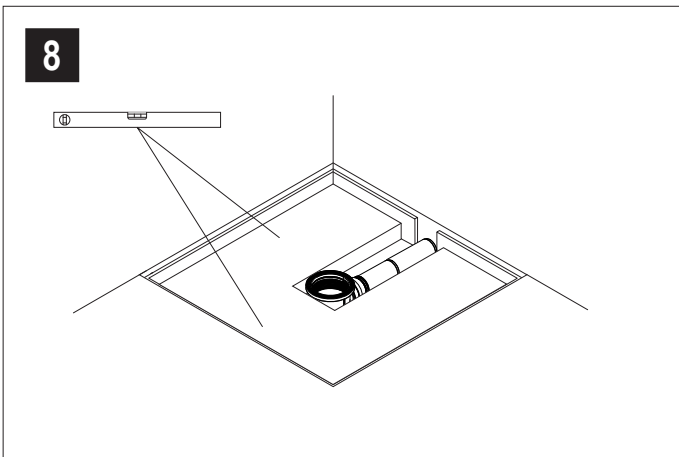

**Einbauanleitung**  
**Mounting instruction**  
**Instructions de montage**  
**Instrucciones de instalación**

Poresta® SELECT Duschelemente  
 Poresta® SELECT Shower elements  
 Poresta® SELECT Douche-elementen  
 Poresta® SELECT Éléments de douche  
 Poresta® SELECT Elementi doccia

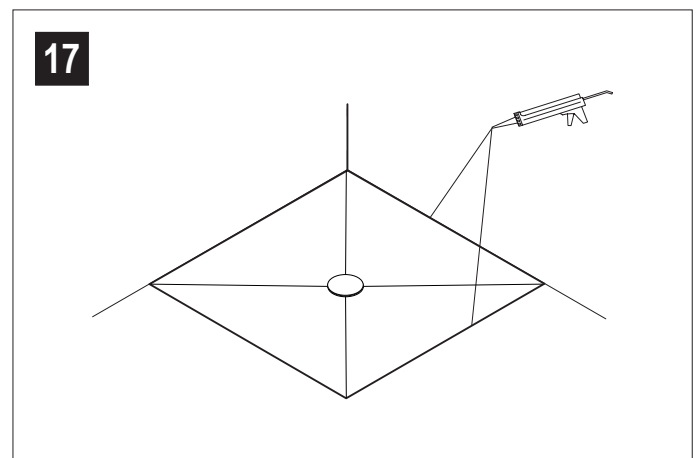
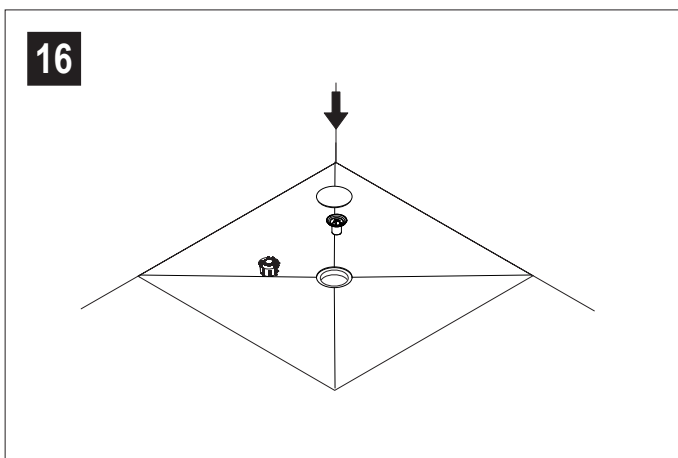
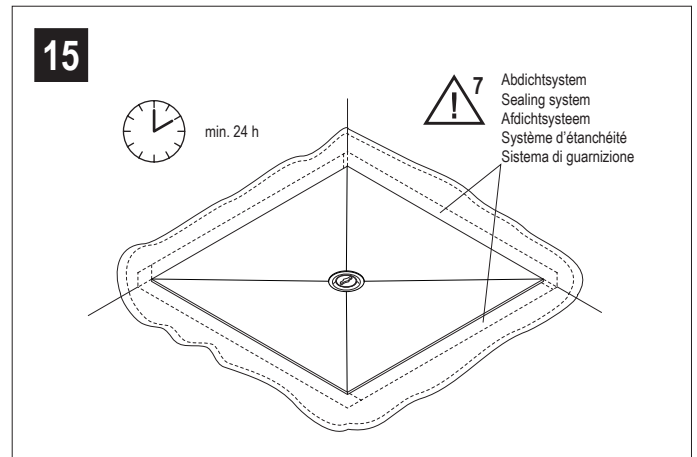
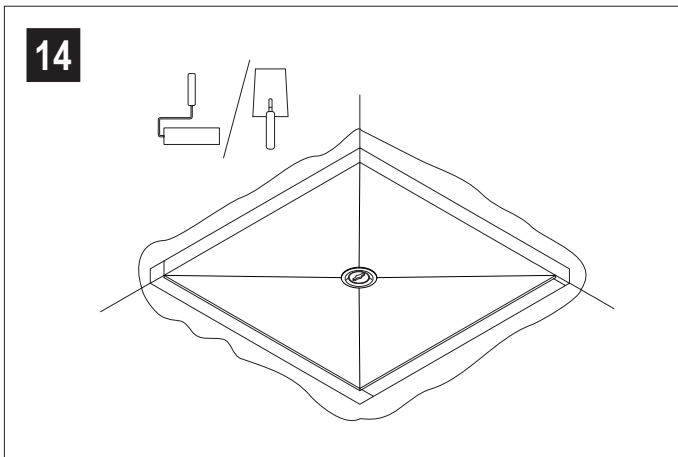

# Einbauanleitung

## Mounting instruction

### Instructions de montage

### Instrucciones de instalación

Poresta® SELECT Duschelemente  
 Poresta® SELECT Shower elements  
 Poresta® SELECT Douche-elementen  
 Poresta® SELECT Éléments de douche  
 Poresta® SELECT Elementi doccia

#### Verwendung:

- Poresta® SELECT Duschelement werden auf Maß geliefert und dürfen nicht gekürzt werden.
- Die Art und Weise der Nutzung des Duschplatzes (Spritzschutz, Bewegungsfläche etc.) ist zu berücksichtigen.
- Für den Einbau des Duschsystems muss ein ebener, sauberer, tragfähiger, schwingungsfreier und für die Verklebung mit Poresta® Profi Flex geeigneter Untergrund vorhanden sein.
- Der richtige Sitz des Ablaufkörpers ist zu prüfen.
- Das Duschsystem ist generell rollstuhlbefahrbar.
- Nur für den Einsatz im Innenbereich geeignet.
- Bei aufsteigenden Anschlüssen muss mindestens eine 5 mm große Fuge zwischen den Poresta® SELECT Wandelement oder der Verfließung und dem Poresta® SELECT Duschelement bleiben. Zwischen dem Poresta® SELECT Duschelement und dem angrenzenden Boden muss mindestens eine 8 mm große Fuge ausgeführt werden.

 **7** Die Verarbeitungshinweise des Abdichtsystems sind zu beachten. **Es ist ein geeignetes Abdichtsystem zu verwenden.**

 **8** Die Ecken des Dichtbandes an den vorgeprägten Stellen falten. Das Dichtband und die sich ergebenden Überlappungen sind vollständig mit Dichtmasse einzudichten.

 **9** Einbaubeispiel mit Unterbauelement (X):

Aufbauhöhe/Fertigfußboden	120 mm
Poresta® SELECT Duschelement	- 50 mm
2 Lagen Fliesenkleber	- 10 mm
Unterbauelement (X)	= 60 mm

 Die einschlägigen Verarbeitungsrichtlinien aller beteiligten Gewerke und des Montagezubehörs sind zu berücksichtigen.

 Oberfläche bei der Montage mit z.B. Pappe vor Beschädigungen schützen.

 **1** Beim Einbau müssen Unterbauelemente (nicht im Lieferumfang) verwendet werden. Die Höhe des Unterbauelementes ist anhand des Höhenunterschiedes zwischen Rohfußboden und Fertigfußboden zu wählen (siehe auch Einbaubeispiele).

 **2** Randdämmstreifen sind bauseits zu stellen.

 **3** Poresta® Profi Flex beidseitig auftragen.

 **4** Die Ablaufgarnitur muss mit geeignetem schalldämmenden Material unterlegt werden.

 **5** Nach Installation der Ablaufgarnitur ist eine Ablaufprüfung und Dichtigkeitsprüfung durchzuführen.

 **6** Bauen Sie das Poresta® SELECT Duschelement in Waage ein und beschweren Sie es flächig (z. B. mit Zementsäcken). Im Anschluss muss die Gefällelinie zum Abfluss nochmals geprüft werden.

# Einbauanleitung

## Mounting instruction



### Instructions de montage

### Instrucciones de instalación

Poresta® SELECT Duschelemente  
 Poresta® SELECT Shower elements  
 Poresta® SELECT Douche-elementen  
 Poresta® SELECT Éléments de douche  
 Poresta® SELECT Elementi doccia

Use:

- Poresta® Shower Elements are delivered made-to-measure and do not need to be shortened.
- The kind of utilization of the shower space (splash protection, movement area, etc.) is to be considered.
- For the installation of the shower system a level, clean, solid surface free of vibrations and suited for fastening with Poresta® Profi Flex must be available.
- The correct fitting of the discharge element is to be checked.
- The shower system is in general wheelchair-accessible.
- Suitable only for use indoor.
- For ascending connections, a joint of at least 5 mm must be left between the Poresta® Select wall element or the tiling and the Poresta® Select Shower Element. A joint of at least 8 mm needs to be made between the Poresta® Select Shower Element and the adjoining floor.

-  7 The processing instructions of the sealing system are to be observed. A suitable sealing system must be used.
-  8 Fold the corners of the sealing tape at the premarked points. The sealing tape and the resulting overlaps must be completely sealed with sealing compound.
-  9 Example for installation with substructure element (X):
 

Mounting height/finished floor level	120 mm
Poresta® SELECT Shower Element	- 50 mm
2 layers of tile adhesive	-10 mm
Substructure element (X)	= 60 mm

 The relevant processing guidelines for all trades working on the job and for the accessories to be fitted need be observed.

 During fitting, protect the surface from damage using a suitable material such as cardboard.

 1 For installation substructure elements (not included in supply,) are to be used. The height of the substructure element is to be selected according to the difference in height between the raw floor and the room flooring (see also installation examples).

 2 Edge insulation strips are to be provided locally.

 3 Apply Poresta® Profi Flex to both sides.

 4 The drain fitting must possibly be lined with suitable sound absorbing material.

 5 After installation of the drain fitting, a leakage test and a seal-tight test must be carried out.

 6 Install the Poresta® Shower Elements in scale and weigh it down flat (e.g., with cement sacks). Subsequently, the gradient line to the outflow must be checked again.



# Einbauanleitung

## Mounting instruction

### Instructions de montage

### Instrucciones de instalación

Poresta® SELECT Duschelemente  
 Poresta® SELECT Shower elements  
 Poresta® SELECT Douche-elementen  
 Poresta® SELECT Éléments de douche  
 Poresta® SELECT Elementi doccia

#### Toepassing:

- De grootte van het douchesysteem kan niet worden gewijzigd.
- Er moet ook rekening worden gehouden met de gebruikswijze van de douche (spatbescherming, bewegingsruimte enz.).
- Voor de montage van het douchesysteem moet een vlakke, schone, draagkrachtige, trilvrije en voor verwerking van de Poresta® Profi Flex geschikte ondergrond aanwezig zijn.
- De correcte zitting van het afloopelement moet worden gecontroleerd.
- Het douchesysteem is over het algemeen rolstoelgeschikt.
- Alleen geschikt voor toepassing in binnenruimte.
- Voor oplopende verbindingen moet tenminste een 5 mm brede voeg overblijven tussen het Poresta® Select wandelement of de tegels en het Poresta® Select douche-element. Tussen het Poresta® Select douche-element en de aangrenzende vloer moet een voeg van tenminste 8 mm breed aanwezig zijn.

 7 De verwerkingsaanwijzingen van het afdichtingsysteem moeten worden opgevolgd. Er moet een geschikt afdichtingssysteem worden gebruikt.

 8 De hoeken van de afdichtingstape vouwen op de voor-gepreegde punten. De afdichtingstape en de overlappingsen ervan moeten volledig worden afgedicht met voegmiddel.

 9 Montagevoorbeeld met Poresta® BF onderbouwelement (X):

Opbouwhoogte/afgewerkte vloer	120 mm
Poresta® SELECT Douche-element	- 50 mm
2 lagen tegelplakker	- 10 mm
Onderbouwelement (X)	= 60 mm

 Met de betreffende verwerkingsrichtlijnen van alle betrokken onderdelen moet rekening worden gehouden.

 Verwijder de beschermfolie van het douchesysteem pas als de tegels zijn gelegd. Als op de achterzijde tegellijm wordt aangebracht, Loft beschermen door met het oppervlak naar beneden op karton te leggen.

 1 Bij inbouwen moeten de onderbouwelementen (niet in de levering inbegrepen) worden toegepast. De hoogte van het onderbouwelement/estrikkondergrond moet aan de hand van het hoogteverschil tussen onafgewerkte vloer en kamerestrik worden gekozen (zie ook installatievoorbeelden).

 2 Randdichtingsstroken zijn niet in de levering inbegrepen.

 3 Poresta® Profi Flex aan beide kanten aanbrengen.

 4 De afvoergarnituur moet eventueel met geschikt geluiddempend materiaal worden geïsoleerd.

 5 Na de installatie van de waterafvoer moet een dichtheidscontrole worden uitgevoerd.

 6 Installeer de Poresta® douchelementen in de weegschaal en weeg het plat (bijv. Met cementzakken). Vervolgens moet de hellingslijn naar de afvoer opnieuw worden gecontroleerd.



# Einbauanleitung

## Mounting instruction

### Instructions de montage

### Instrucciones de instalación

Poresta® SELECT Duschelemente  
 Poresta® SELECT Shower elements  
 Poresta® SELECT Douche-elementen  
 Poresta® SELECT Éléments de douche  
 Poresta® SELECT Elementi doccia

#### Utilisation:

- Poresta® Shower Elements sont livrés sur mesure et ne doivent pas être raccourcis.
- Il faut prendre en considération le mode d'utilisation du poste de douche (protection contre la projection de gouttes d'eau, espace de mouvement etc.).
- Pour l'installation du système de douche, il est nécessaire de disposer d'une surface de base plane, propre, capable de porter le système, antivibratoire et appropriée à l'application de Poresta® Profi Flex.
- L'ajustement correct de l'élément d'écoulement est à contrôler.
- En général, le système de douche est accessible en fauteuil roulant.
- Ne se prête qu'à l'installation à l'intérieur de bâtiments.
- Pour les raccordements ascendants, il faut laisser un joint d'au moins 5 mm entre l'élément mural Poresta® Select ou le carrelage et l'élément de douche Poresta® Select. Il faut prévoir un joint d'au moins 8 mm entre l'élément de douche Poresta Select et le sol adjacent.

 6 Installez l'élément de douche Poresta® sur la balance et pesez-le (par ex. avec des sacs de ciment). Ensuite, la ligne de gradient vers le drain doit être vérifiée à nouveau.

 7 Respecter les instructions de mise en œuvre du système d'étanchéité. Il faut utiliser un système d'étanchéité approprié.

 8 Plier les coins de la bande d'étanchéité sur les zones préparées. La bande d'étanchéité et les chevauchements doivent être recouverts intégralement de mastic.

 9 Esempio d'installazione con elemento di spessore (X):

Altezza di montaggio/ pavimento finito	120 mm
Poresta® SELECT Élément de douche	- 50 mm
N. 2 strati di collante per piastrelle	-10 mm
Elemento di spessore (X)	= 60 mm

 Il faut tenir compte de toutes les directives de travail de tous les corps de métier impliqués et des accessoires de montage.

 Lors du montage, protéger des dégradations, par ex. avec du carton.

 1 Pour l'installation, il faut utiliser des éléments de support de base (pas compris dans la fourniture). Choisir la hauteur de l'élément de support de base selon la différence de hauteur entre le sol brut et la chape de la salle (voir exemples d'installation).

 2 Les bandes isolantes de bord sont à prévoir par le client.

 3 Appliquer Poresta® Profi Flex sur les deux faces.

 4 Le cas échéant, de la matière insonorisante doit être posée sous la garniture d'écoulement.

 5 Après l'installation de l'ensemble de drainage, il faut réaliser un test de procédé et un contrôle d'étanchéité.

# Einbauanleitung

## Mounting instruction

### Instructions de montage

### Instrucciones de instalación

Poresta® SELECT Duschelemente  
 Poresta® SELECT Shower elements  
 Poresta® SELECT Douche-elementen  
 Poresta® SELECT Éléments de douche  
 Poresta® SELECT Elementi doccia

#### Uso:

- La grandezza del Poresta® Shower Elements non può essere modificata.
- Si deve prendere in considerazione il modo d'utilizzazione del posto di doccia (protezione contro gli spruzzi di acqua, spazio di movimento ecc.).
- Per l'installazione del sistema doccia deve esistere un sottosuolo piano, pulito, solido, libero di vibrazioni e adatto per l'incollaggio per mezzo del Poresta® Profi Flex.
- L'aggiustaggio corretto dell'elemento di scolo è da controllare.
- Generalmente il sistema di doccia è accessibile in sedia a rotelle.
- Adatto solo per l'uso interno.
- Nel caso di collegamenti ascendenti deve rimanere una fuga di almeno 5 mm tra l'elemento a parete Poresta® Select o la piastrellatura e l'elemento doccia Poresta® Select. Tra l'elemento doccia Poresta Select e il fondo adiacente deve essere eseguita una fuga di almeno 8 mm.

 6 Installare gli elementi doccia Poresta® nella bilancia e appesantirli (ad es. con sacchi di cemento). Successivamente, la linea di inclinazione verso lo scarico deve essere ricontrollata.

 7 Le istruzioni di lavorazione del sistema di guarnizione devono essere osservate. Va utilizzato un sistema di impermeabilizzazione adatto.

 8 Piegare gli angoli del nastro di sigillatura nelle aree evidenziate. Il nastro di sigillatura e le sovrapposizioni vanno sigillati completamente con il materiale di tenuta.

 9 Esempio d'installazione con elemento di spessore (X):

Altezza di montaggio/ pavimento finito	120 mm
Poresta® SELECT Elemento doccia	- 50 mm
N. 2 strati di collante per piastrelle	-10 mm
<hr/>	
Elemento di spessore (X)	= 60 mm

 Si deve osservare le istruzioni di lavorazione di tutti i mestieri partecipanti.

 Togliere la foglia protettiva dal sistema di doccia soltanto dopo la posa delle piastrelle. Proteggere la superficie Loft con un cartone mentre si spalma la colla per piastrelle sul retro.

 1 Per l'installazione elementi di spessore (non compresi nella consistenza di fornitura) devono essere usati. L'altezza dell'elemento di spessore/dello zoccolo di pavimento deve essere scelta secondo la differenza d'altezza tra fondo grezzo e pavimento camera (vedi anche esempi d'installazione).

 2 Fasce isolanti di bordo devono essere messe a disposizione localmente.

 3 Applicare Poresta® Profi Flex su entrambi i lati.

 4 L'elemento di scarico deve essere rivestito in caso con materiale isolante addetto.

 5 Dopo l'installazione dell'elemento di scarico, si deve procedere ad una prova d'ermeticità.

**Einbauanleitung**  
**Mounting instruction**  
**Instructions de montage**  
**Instrucciones de instalación**

Poresta® SELECT Duschelemente  
Poresta® SELECT Shower elements  
Poresta® SELECT Douche-elementen  
Poresta® SELECT Éléments de douche  
Poresta® SELECT Elementi doccia

---

Empfohlenes Zubehör / Recommended accessories /  
Aanbevolen toebehoren / Accessoires recommandés /  
Accessori raccomandati:



Poresta® Profi-Flex / Profi-Flex / Profi-Flex /  
Profi-Flex / Profi-Flex



Poresta® Abdichtsystem / Sealing system / Afdichtsystem /  
Mastic d'étanchéité / Sistema di guarnizione

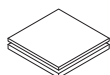

Poresta® BF Unterbauelement / Substrate element /  
Onderbouwelement / Élément de réhausse / Sottostruttore



Silikon / Silicone / Siliconen / Silicone / Silicone