



Ihr Online-Fachhändler für:



- Kostenlose und individuelle Beratung
- Hochwertige Produkte
- Kostenloser und schneller Versand

- TOP Bewertungen
- Exzelerter Kundenservice
- Über 20 Jahre Erfahrung



E-Mail: info@unidomo.de | Tel.: 04621 - 30 60 89 0 | www.unidomo.de

Einbauanleitung
Mounting instruction
Montagehandleiding
Instructions de montage
Istruzioni di montaggio

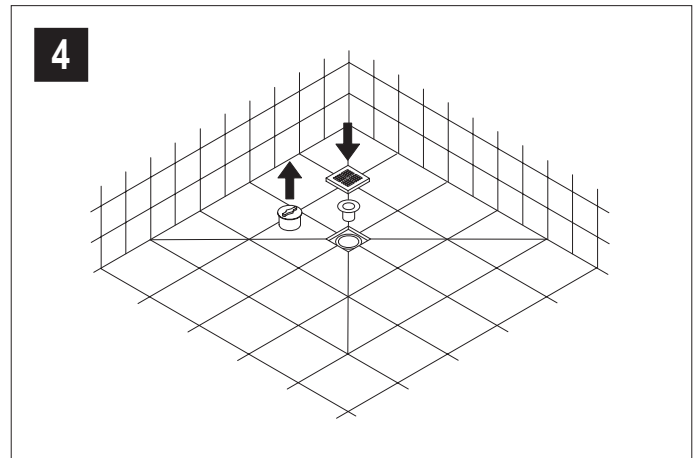
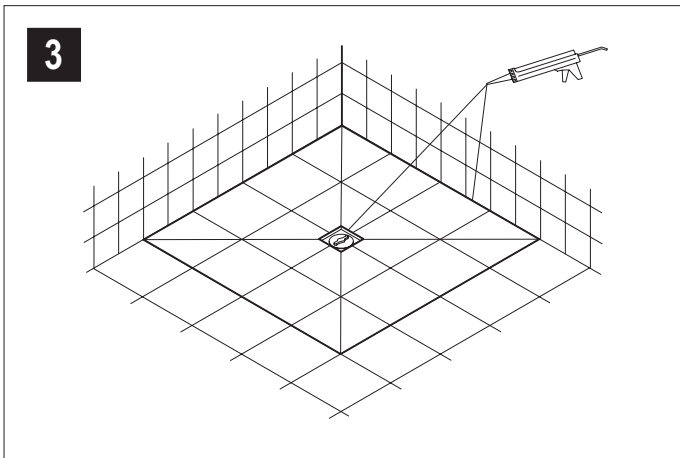
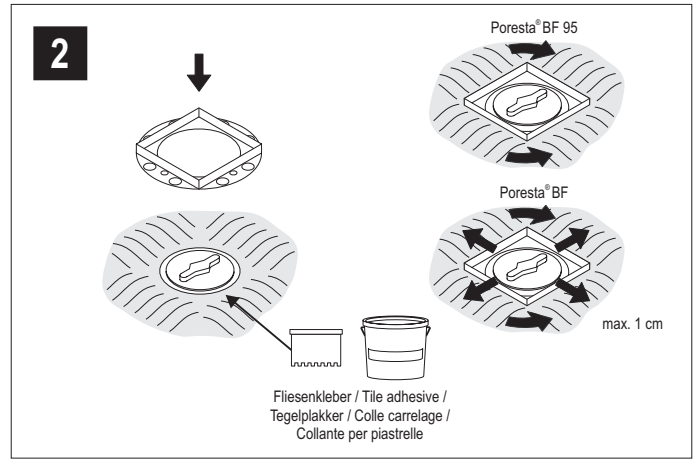
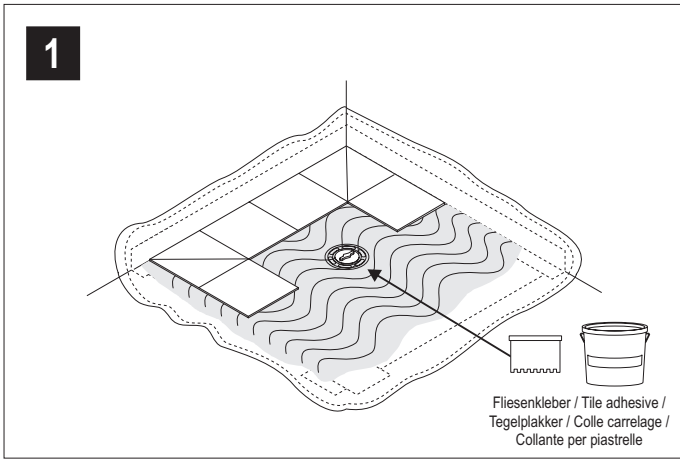

























Einbauanleitung

Mounting instruction

Montagehandleiding

Instructions de montage

Istruzioni di montaggio

-  Die einschlägigen Verarbeitungsrichtlinien aller beteiligten Gewerke und des zum Einsatz kommenden Verarbeitungsbehörs sind zu berücksichtigen.
-  Nur für den Einsatz im Innenbereich geeignet.
-  Das Duschesystem ist generell rollstuhlfahrbar unter Verwendung von Fliesen mit einer Mindestgröße 100 x 100 mm. Bei Einarbeitung eines Glasgewebes in das Fliesenkleberbett können auch Fliesen mit einer Mindestgröße 50 x 50 mm verwendet werden.
-  Ausschließlich zugelassenen und für den jeweiligen Fliesenbelag geeigneten Fliesenkleber und Fugenmörtel verwenden.
-  Ein ausreichendes Gefälle zum Ablauf ist zu berücksichtigen.
-  The relevant processing guidelines of all trades involved must be observed.
-  Suitable only for use indoor.
-  The shower system is generally accessible for wheel chairs when using tiles of a minimum size of 100 x 100 mm. If glass fabric is worked into the tile adhesive bed, also tiles of a minimum size of 50 x 50 mm may be used.
-  Use the tile adhesive and joint mortar exclusively admitted for the respective tile flooring.
-  A sufficient slope to the discharge is to be taken into consideration.
-  Met de betreffende toepassingsrichtlijnen van alle betrokken onderdelen moet rekening worden gehouden.
-  Alleen geschikt voor toepassing in binnenruimte.
-  Het douchesysteem is in principe voor een rolstoel geschikt, als tegels met een minimale grootte van 100 x 100 mm worden toegepast. Bij verwerking van glasvezelmateriaal in de plakondergrond kunnen ook tegels van minimaal 50 x 50 mm worden gebruikt.
-  Gebruik uitsluitend goedgekeurde en voor de betreffende tegelbekleding geschikte tegelijm en voegmortel.
-  Houd rekening met voldoende helling naar de afvoer.
-  Les instructions correspondantes de mise en oeuvre de tous les métiers participants sont à respecter.
-  Ne se prête qu'à l'installation à l'intérieur de bâtiments.
-  En général, le système de douche permet l'accès en fauteuil roulant à la condition de poser des carreaux d'une dimension minimale de 100 x 100 mm. Si le lit de pose des carreaux est renforcé par un tissu de fibres de verre, il est possible d'utiliser également des carreaux d'une dimension minimale de 50 x 50 mm.
-  N'utiliser qu'exclusivement de la colle pour carreaux et du mortier de jointoiement approuvés et appropriés au carrelage respectif.
-  Prévoir une pente suffisante vers l'écoulement.
-  Si deve osservare le istruzione corrispondenti di lavorazione di tutti i mestieri partecipanti.
-  Adatto solo per l'uso in locali chiusi.
-  Il sistema doccia è generalmente accessibile con sedia a rotelle, se piastrelle di una grandezza minima di 100 x 100 mm sono usate. Ad integrazione di un tessuto di vetro nel letto d'incollaggio piastrelle anche piastrelle di una grandezza minima di 50 x 50 mm possono essere usate.
-  Utilizzare solo colla per piastrelle e malta per giunti approvate ed adatte per il pavimento a piastrelle rispettivo.
-  Rispettare una pendenza sufficiente verso lo scarico.