



Ihr Online-Fachhändler für:



- Kostenlose und individuelle Beratung
- Hochwertige Produkte
- Kostenloser und schneller Versand

- TOP Bewertungen
- Exzelerter Kundenservice
- Über 20 Jahre Erfahrung



E-Mail: info@unidomo.de | Tel.: 04621 - 30 60 89 0 | www.unidomo.de

Einbauanleitung

Poresta® BEDS Schallentkopplungsmatte (Komplettset)

Mounting instructions

Poresta® BEDS antiresonant mat (complete set)

Montagehandleiding

Poresta® BEDS geluidsisolatiemat (compleet set)

Instructions de montage

Matelas d'isolation acoustique Poresta® BEDS (jeu complet)

Istruzioni di montaggio

Stuoia d'isolamento acustico Poresta® BEDS (set completo)

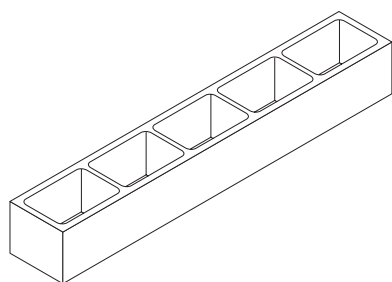

Poresta® Schalungselemente /
Encasing elements /
Bekistingsselementen /
Eléments de coffrage /
Elementi di cassaforma

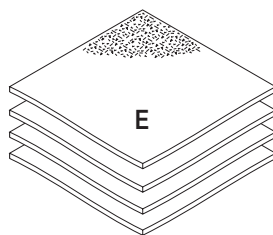

Poresta® Schallentkopplungsmatte /
Antiresonant mat /
Geluidsisolatiemat /
Matelas d'isolation acoustique /
Stuoia d'isolamento acustico

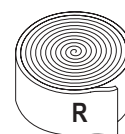

Poresta® Randdämmstreifen /
Edge insulation strips /
Randdichtingsstroken /
Bande isolante de bord /
Fascia isolante di bordo

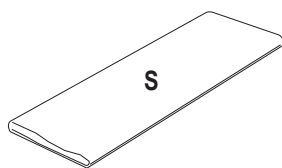

Poresta® Schalldämpfungsmatte /
Sound absorbing mat /
Geluiddempingsmat /
Matelas insonorisant /
Stuoia insonorizzante

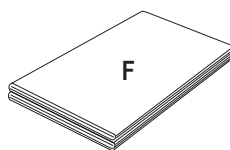

Poresta® Baufolie /
Construction foil /
Bouwfolie /
Feuille de bâtiment /
Foglio da costruzione

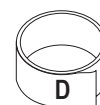

Poresta® Klebeband /
Adhesive strip /
Plakband /
Ruban adhésif /
Nastro adesivo

For notes and further information see page 8 /
Aanwijzingen en verdere informatie zie pagina 8 /
Renseignements et informations complémentaires, voir page 9 /
Riferimenti e ulteriori informazioni, vedi pagina 10

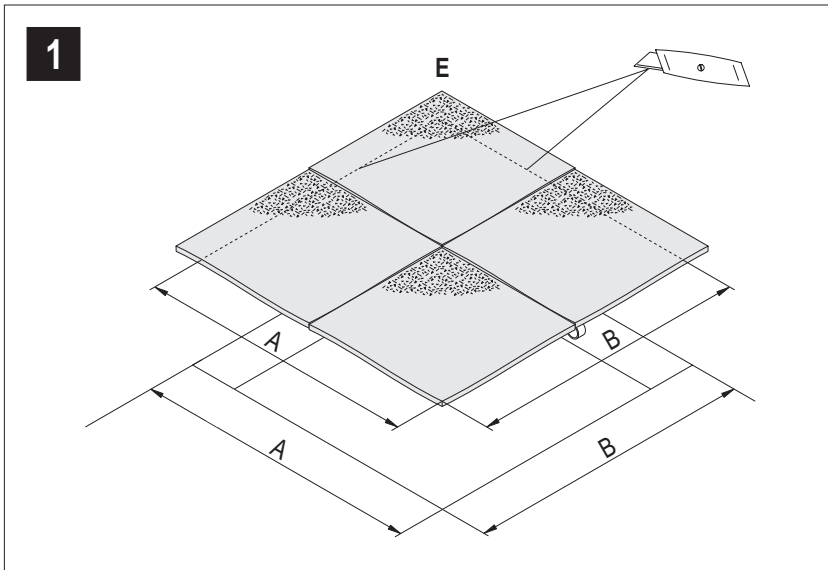

Die einschlägigen Verarbeitungsrichtlinien aller beteiligten Gewerke sind zu berücksichtigen.



Für die Verwendung des Schallschutzsets in Verbindung mit den Poresta® bodenebenen Duschsystemen sind Schallprüfzeugnisse verfügbar. Zur Einhaltung der gemessenen Installationsschallpegel müssen die aufgeführten Poresta® Produkte fachgerecht verwendet werden.



Direkter Kontakt des Estrich mit dem angrenzenden Boden und den Wänden ist zu vermeiden.

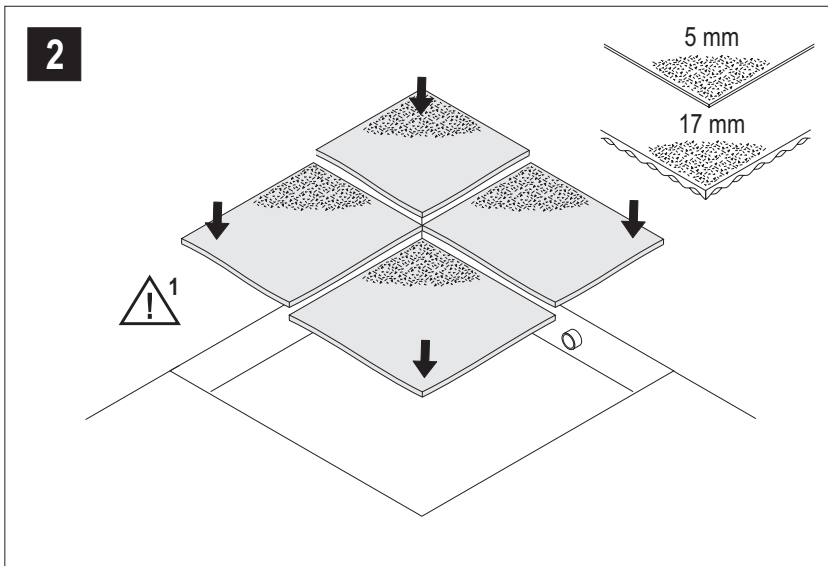

Für den Einbau muss ein ebener, sauberer, tragfähiger und schwingungsfreier Untergrund vorhanden sein.



Der Boden im Bereich des Duschsystems muss planeben sein (gegebenenfalls mit Ausgleichsmasse nacharbeiten).





Die Einbauanleitung des jeweiligen Duschsystems ist zu beachten.



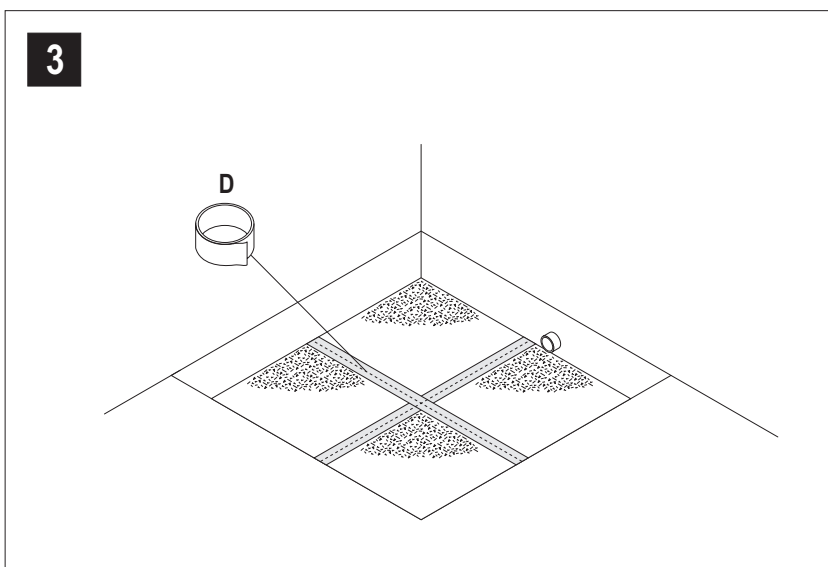

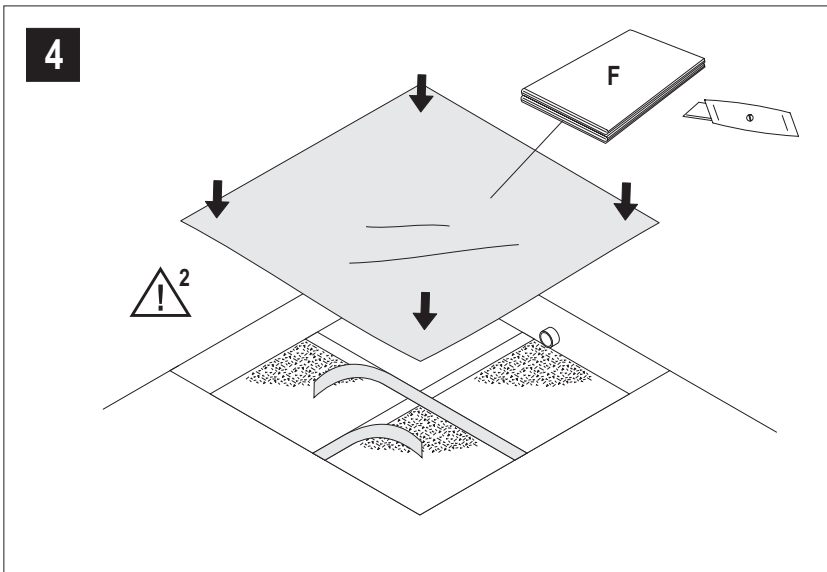
¹ Poresta® Schallentkopplungsmatte lose auflegen.



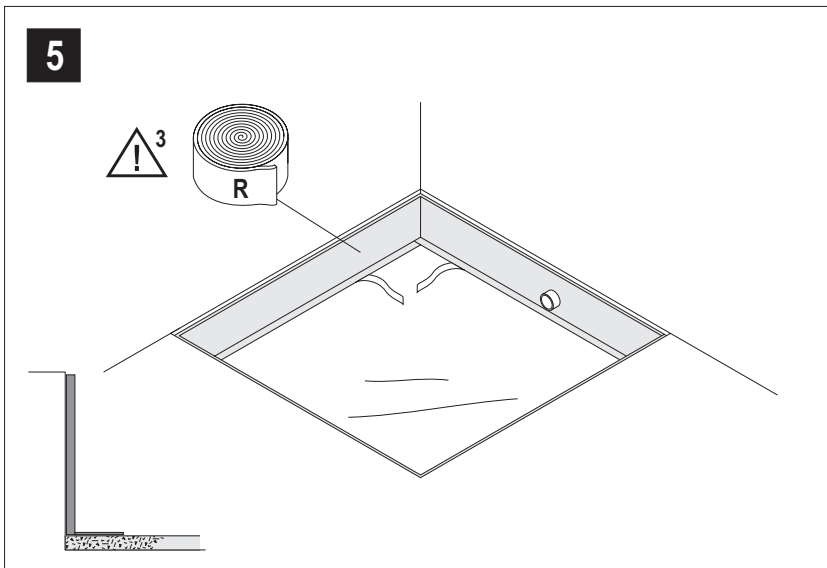

 ² Schutzfolie vom Klebeband entfernen und Schallentkopplungsmatten vollflächig mit Baufolie abdecken.



 ³ Randdämmstreifen umlaufend auf die Baufolie kleben.

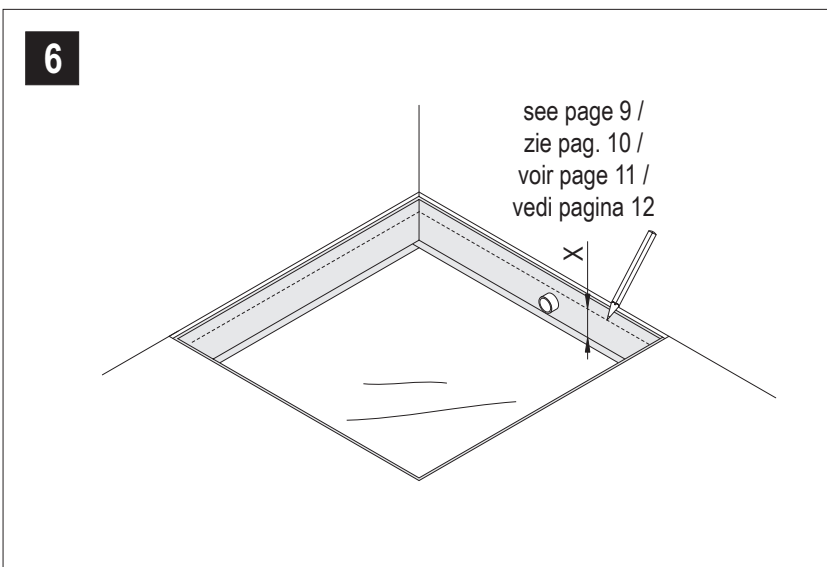



Ermittlung der Höhe des Estrichsockels ($X \geq 40$ mm):

Aufbauhöhe/Rohfussboden	140 mm
Schallentkopplungsmatte 5 mm	- 5 mm
Höhe Duschsystem* (max.)	- 45 mm
1 Lage Fliesenkleber	- 5 mm
Höhe (X)	= 85 mm

Aufbauhöhe/Rohfussboden	140 mm
Schallentkopplungsmatte 17 mm	- 17 mm
Höhe Duschsystem* (max.)	- 45 mm
1 Lage Fliesenkleber	- 5 mm
Höhe (X)	= 73 mm

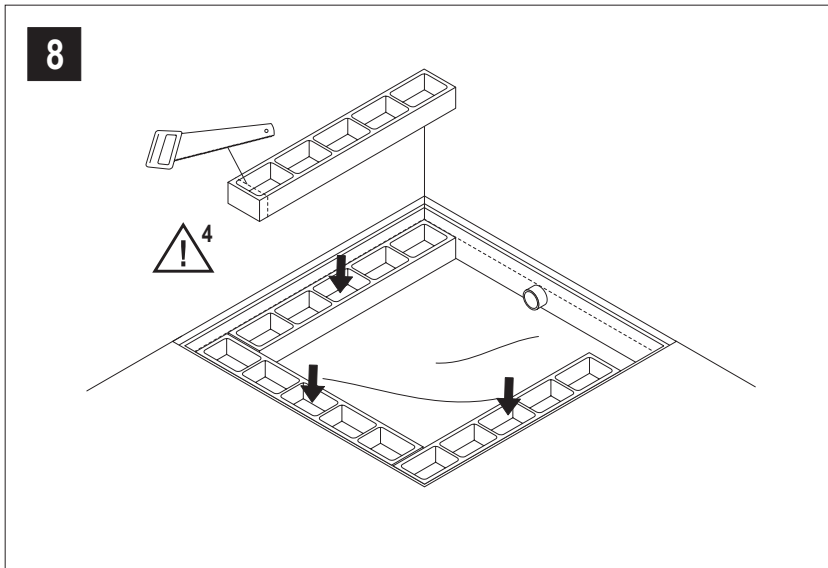
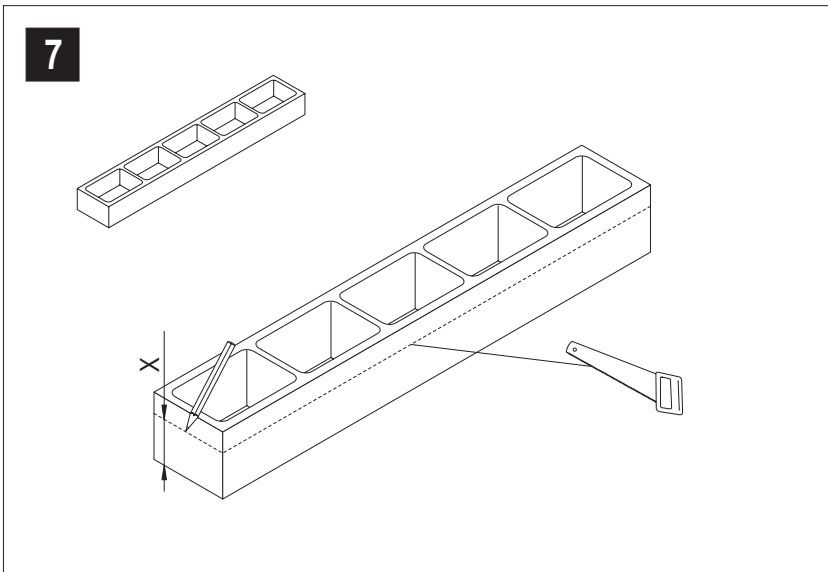
* Beispiel für Duschsystem: BF KMK (900 x 900 x 45 mm, waagerechter Ablauf, zentriert)



 ⁴ Die Schalungselemente sind gegebenenfalls entsprechend zu kürzen.

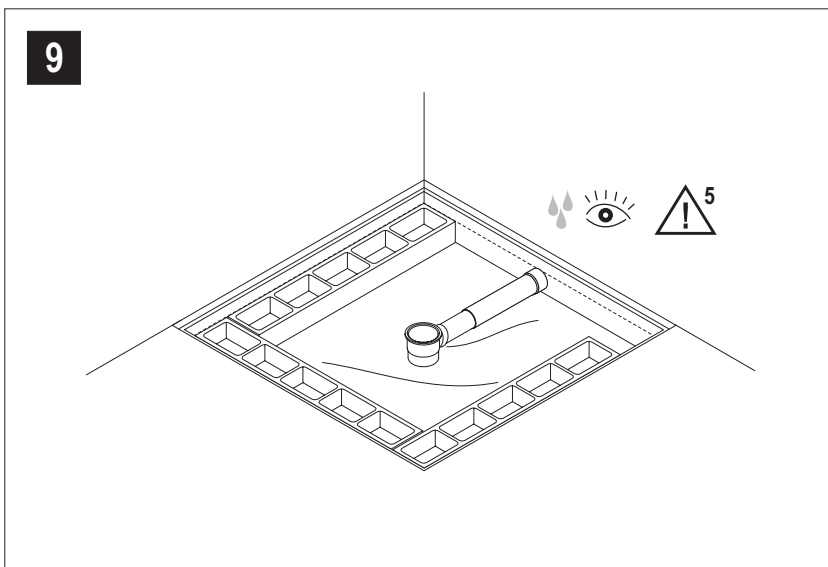

 ⁵ Nach Installation der Ablaufgarnitur ist eine Dichtigkeitsprüfung durchzuführen.



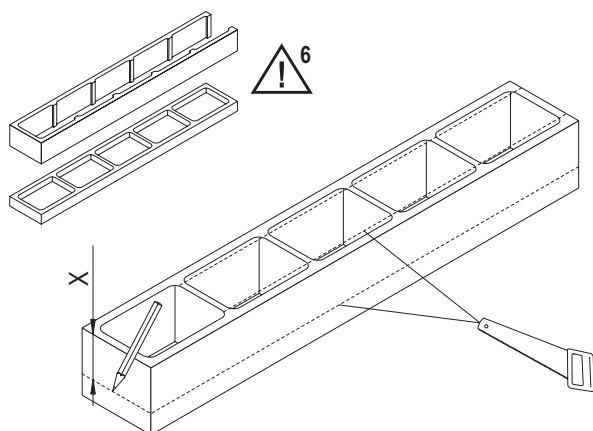

10

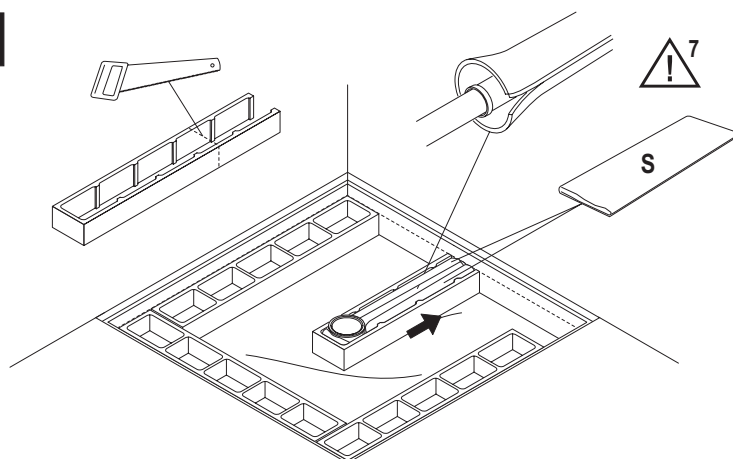

 ⁶ Der Ablaufschacht ist während der Estrich-verfüllarbeiten zu verschließen.

11



 ⁷ Vor dem Verschließen des Ablaufschachtes eine geeignete Wärme- und Schallschutzummantelung (nicht im Lieferumfang) an der Ablaufleitung anbringen. Hohlräume des Ablaufschachtes mit Zuschnitten der Schalldämmungsmatte (S) ausfüllen. Schalldämmungsmatte bei Poresta® BF 95 und Poresta® Limit S nicht verwenden.

12

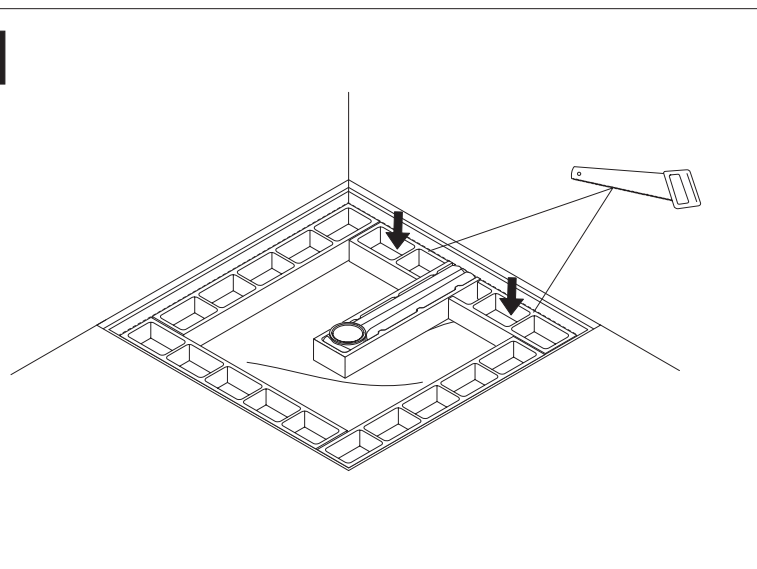

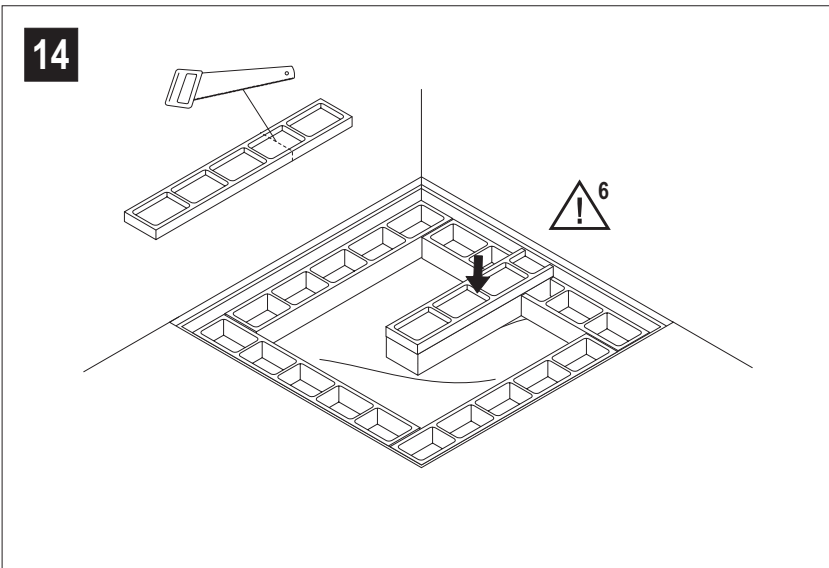
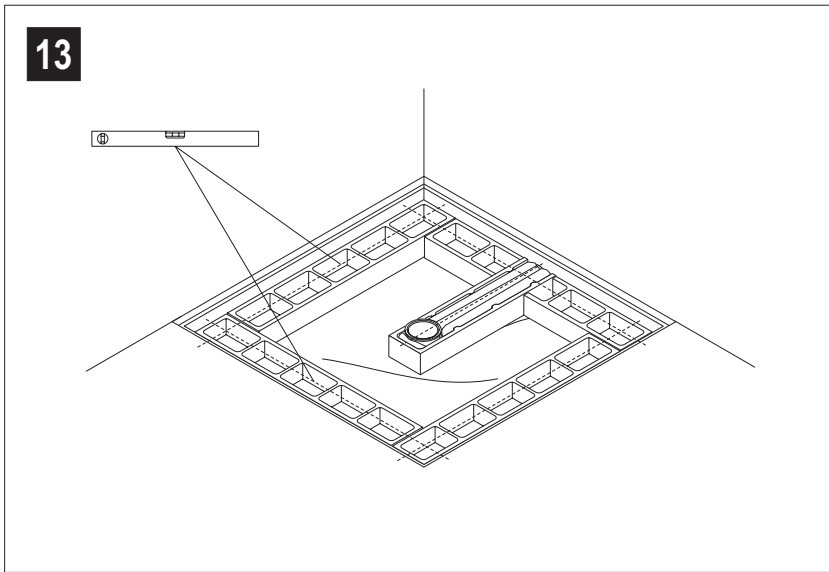

 ⁶ Der Ablaufschacht ist während der Estrich-verfüllarbeiten zu verschließen.

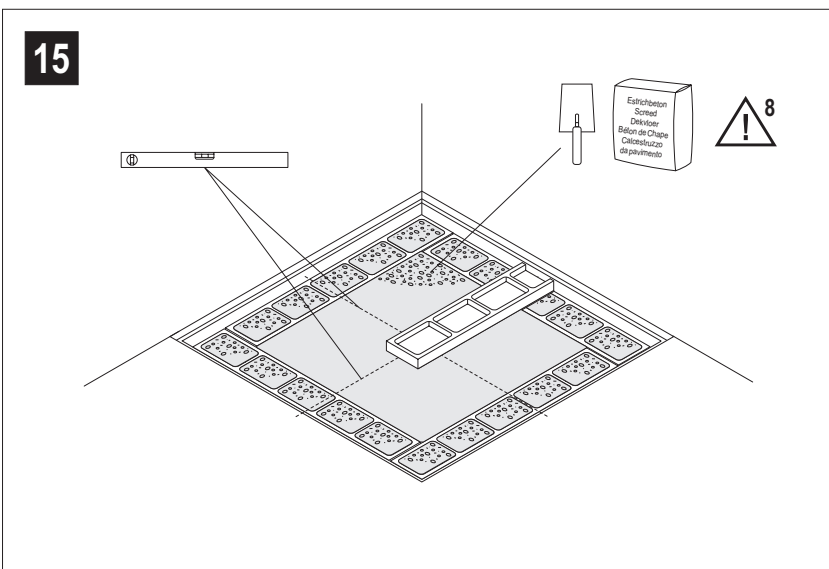

 ⁸ Die Verarbeitungshinweise und Aushärtzeiten des Estrichbetons sind zu beachten.

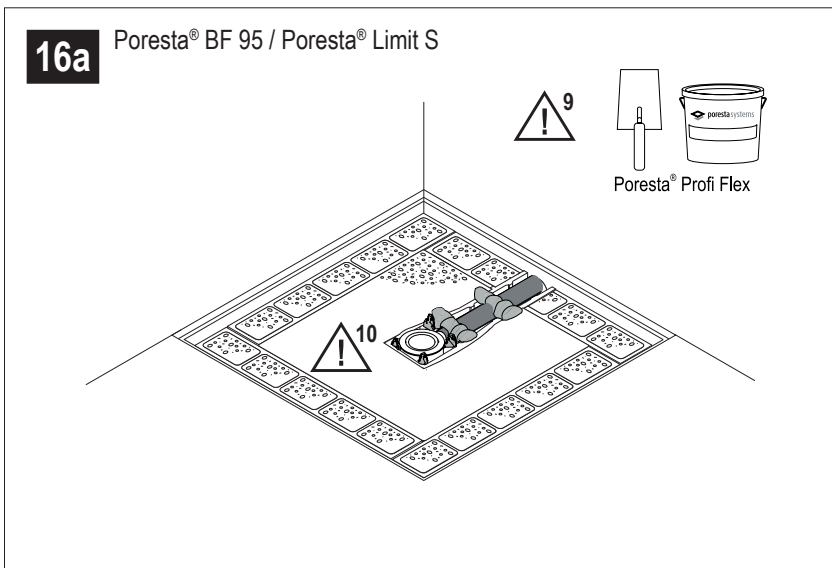
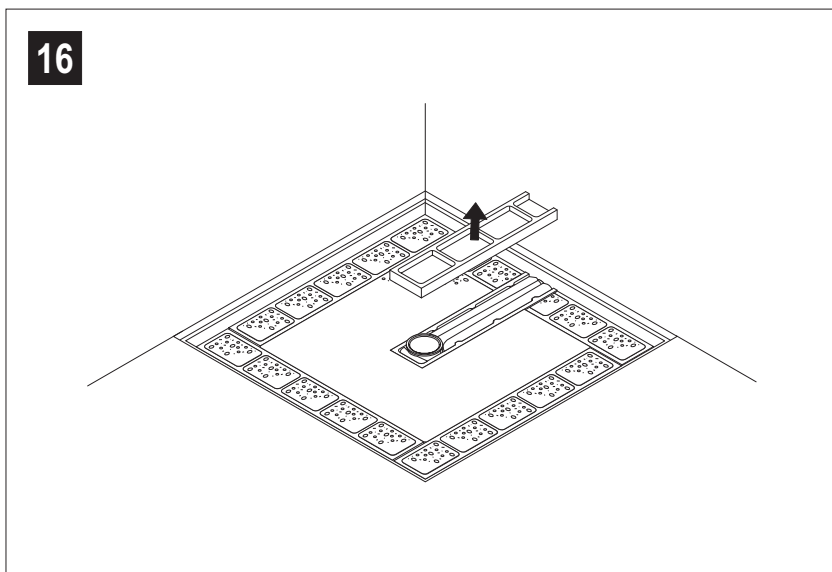

! 9 Abstützung des Ablaufbereichs mit Poresta® Wannenträgermontageschaum oder Poresta® Profi Flex.

! 10 Im Bereich des Ausschnitts für den Abflautopf ausreichend Poresta® Profi Flex in den vier Ecken einbringen. Dabei darf die Dichtfläche des Abflautopfes nicht verschmutzt werden!

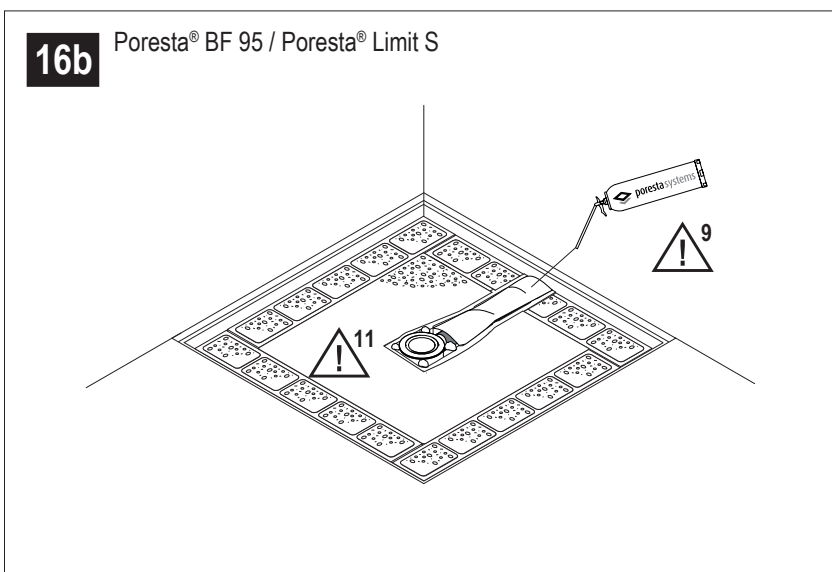





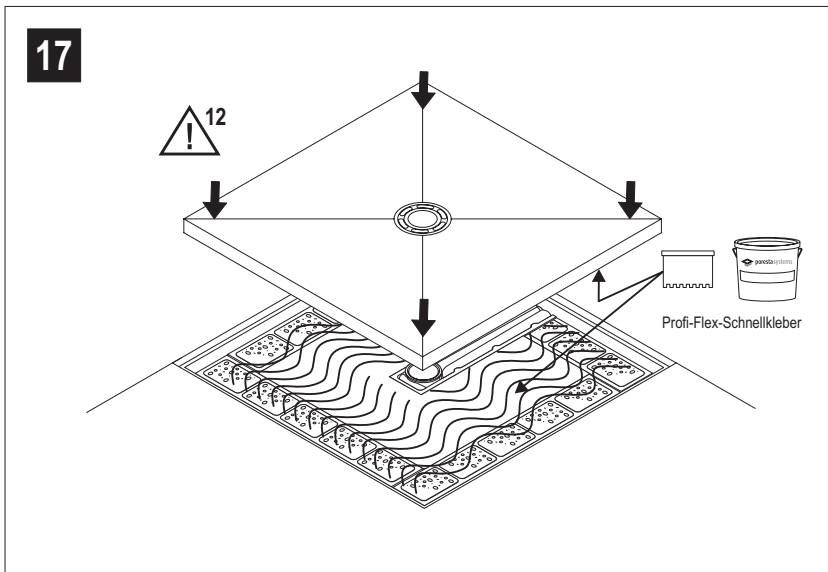











! 9 Abstützung des Ablaufbereichs mit Poresta® Wannenträgermontageschaum oder Poresta® Profi Flex.

! 11 Im Bereich des Ausschnitts für den Abflautopf ausreichend Poresta® Wannenträger-Montageschaum in den vier Ecken einbringen. Dabei darf die Dichtfläche des Abflautopfes nicht verschmutzt werden!



! 12 Der weitere Einbau des Duschelementes erfolgt gemäß der jeweiligen Einbauanleitung.

-  The relevant working guidelines of all the trades involved shall be observed.
-  Sound test certificates are available for the use of the sound proofing set in connection with the Poresta® flush shower systems. The Poresta® products must be used expertly to observe the measured installation sound level.
-  Direct contact of the screed with the adjacent concrete and walls should be avoided.
-  For installation, a flat, clean, firm and vibration-less substrate is required.
-  The floor in the area of the shower system should be absolutely flat (if necessary, rework with levelling compound).
-  The respective shower system installation instructions must be observed.
-  1 Place the Poresta® soundproofing mat loosely in position.
-  2 Remove protective foil from adhesive strip and cover the antiresonant mat over the complete surface with construction foil.
-  3 Stick edge insulation strips to the construction foil all around.
-  4 The encasing elements are to be shortened, if required.
-  5 After the installation of the drain fitting, a leak test has to be carried out.
-  6 During flooring work the outlet duct is to be closed.
-  7 Before closing the drain duct, provide the drain line with a suitable heat and sound insulation jacketing (not included in the scope of supply). The cavities of the drain duct are to be filled up with cut pieces of the sound absorbing mat (S). Do not use the sound absorption mat on the Poresta® BF 95 and the Poresta® Limit S.
-  8 The manufacturer's processing instructions and setting times of the screed concrete shall be observed.
-  9 Support the area of the water outlet with Poresta® shower tray support expanding foam or Poresta® Profi Flex.
-  10 Apply sufficient Poresta® Profi Flex into the four corners of the cut-out for the drain trap. The sealing surface of the drain trap must not be contaminated while doing this!

 11 In the area of the cut-out for the drain trap, apply sufficient Poresta® bath support mounting foam into the four corners. The sealing surface of the drain trap must not be contaminated while doing this!

 12 Further installation of the shower element is carried out in accordance with the relevant installation instructions.



Determination of the height of the screed base ($X \geq 40$ mm)

Mounting height/raw floor	140 mm
Antiresonant mat 5 mm	- 5 mm
Height of shower system* (max.)	- 45 mm
1 layer of tile adhesive	- 5 mm
Height (X)	= 85 mm

Mounting height/raw floor	140 mm
Antiresonant mat 17 mm	- 5 mm
Height of shower system* (max.)	- 45 mm
1 layer of tile adhesive	- 5 mm
Height (X)	= 73 mm

* Example for shower system: BF KMK (900 x 900 x 45 mm, horizontal outlet, centered)

-  Met de betreffende verwerkingsrichtlijnen van alle betrokken onderdelen moet rekening worden gehouden.
-  Voor de toepassing van de isolatieset in verbinding met Poresta® drempelloze douchesystemen zijn certificaten beschikbaar. Om de mogelijke grenswaarden te bereiken, moeten de genoemde Poresta® producten vakkundig worden verwerkt.
-  Direct contact van de estrik met de aangrenzende ondergrond en de wanden vermijden.
-  Voor montage is een vlakke, schone en zonder vibratie dragende ondergrond aanwezig te zijn.
-  De ondergrond voor het douchesysteem moet gelijkmatig vlak zijn (evt. met spachtelmateriaal bijwerken).
-  De Inbouw instructies van het betreffende douchesysteem moeten geraadpleegd worden.
-  **1** Poresta® geluidsisolatiemat los opleggen.
-  **2** Verwijder beschermfolie van plakband en bedek geluidsisolatiemat over de hele oppervlakte met bouwfolie.
-  **3** Plak randdichtingsstroken rondom op de bouwfolie.
-  **4** De bekistingselementen moeten eventueel passend worden ingekort.
-  **5** Na installatie van de afvoergarnituur moet een dichtheidscontrole worden doorgevoerd.
-  **6** De afvoerschacht tijdens het gieten van de estrik afsluiten.
-  **7** Voor het afsluiten van de afvoerschacht geschikte warmte- en geluidsisolatiemantel (niet in levering inbegrepen) rond de afvoerleiding aanbrengen. Holtes in de afvoerschacht met passend stukken van de geluiddempingsmat (S) opvullen. Bij Poresta® BF 95 en Poresta® Limit S de geluiddempingsmat niet gebruiken.
-  **8** De verwerkingsrichtlijnen en hardingstijden van het estrikbeton moeten worden aangehouden.
-  **9** Ter ondersteuning van de douchevloer Poresta® kuipdragermontageschuim of Poresta® Profi Flex aanbrengen.
-  **10** Op de plaats van de uitsparing voor de afvoerplug, in de vier hoeken voldoende Poresta® Profi Flex aanbrengen. Let er daarbij op dat het afdichtvlak van de afvoerplug niet verontreinigd wordt!

















-  **11** Op de plaats van de uitsparing voor de afvoerplug, in de vier hoeken voldoende Poresta® Baddrager-Montageschuim aanbrengen. Let er daarbij op dat het afdichtvlak van de afvoerplug niet verontreinigd wordt!
-  **12** De verdere installatie van het douche-element volgens de betreffende handleiding.



Berekening hoogte estrikondergrond ($X \geq 40$ mm):

Opbouwhoogte/ruwe vloer	140 mm
Geluidsisolatiemat 5 mm	- 5 mm
Hoogte douchesysteem* (max.)	- 45 mm
1 Laag tegellijm	- 5 mm
Hoogte (X)	= 85 mm

Opbouwhoogte/ruwe vloer	140 mm
Geluidsisolatiemat 17 mm	- 17 mm
Hoogte douchesysteem* (max.)	- 45 mm
1 Laag tegellijm	- 5 mm
Hoogte (X)	= 73 mm

* Voorbeeld voor douchesysteem: BF KMK (900 x 900 x 45 mm, horizontale afloop, gecentreerd)

-  Les directives correspondantes de mise en oeuvre de tous les métiers participants sont à observer.
-  Pour l'utilisation du matériel d'insonorisation en relation avec des systèmes de douche Poresta® à sol plan, des certificats de contrôle du bruit sont disponibles. Pour obtenir les niveaux sonores d'installation mesurés, il est nécessaire d'effectuer la mise en oeuvre des produits Poresta® indiqués conformément aux règles de l'art.
-  Eviter le contact direct entre la chape et le sol adjacent et les murs.
-  Pour le montage, il est nécessaire d'avoir une surface plane, propre, stable et exempte de vibrations.
-  Le sol dans la zone du système de douche doit être plan (le cas échéant, faire des retouches au moyen de masse d'égalisation).
-  Il faut observer la notice de montage du système de douche correspondant.
-  1 Poser le matelas d'insonorisation Poresta® sans le fixer.
-  2 Enlever la feuille de protection du ruban adhésif et couvrir toute la surface des matelas d'isolation acoustique de feuille de bâtiment.
-  3 Coller la bande isolante de bord tout autour de la feuille de bâtiment.
-  4 Le cas échéant, raccourcir de manière correspondante les éléments de coffrage.
-  5 Après installation de la robinetterie d'écoulement, il faut procéder à un contrôle d'étanchéité.
-  6 Fermer la gaine de conduite d'évacuation pendant les travaux de remplissage de la chape.
-  7 Avant de fermer le conduite d'évacuation, la tuyauterie d'évacuation doit être pourvue d'une enveloppe calorifuge et insonorisante appropriée (pas comprise dans la fourniture). Remplir les vides de la conduite d'évacuation de pièces coupées dans le matelas d'isolation acoustique (S). Ne pas utiliser un tapis d'isolation phonique pour Poresta® BF 95 et Poresta® Limit S.
-  8 Respecter le mode de mise en oeuvre et les temps de prise du béton de la chape indiqués par le fabricant.
-  9 Soutien de la zone d'écoulement avec mousse de montage à Poresta® pour support de baignoire ou Poresta® Profi Flex.
-  10 Dans la zone de la découpe pour la cuvette d'écoulement, appliquer Poresta® Profi Flex dans les quatre coins. La surface d'étanchéité de la cuve d'écoulement ne doit pas être salie!













-  11 Dans la zone de la découpe pour la cuvette d'écoulement, appliquer la mousse de montage de support de baignoire Poresta® en couche suffisante dans les quatre coins. La surface d'étanchéité de la cuve d'écoulement ne doit pas être salie !
-  12 L'installation ultérieure des éléments de douche est à effectuer conformément aux instructions de montage respectives.



Détermination de la hauteur du socle de chape ($X \geq 40$ mm):

Hauteur de montage/plancher brut	140 mm
Matelas d'isolation acoustique 5 mm	- 5 mm
Hauteur système de douche* (max.)	- 45 mm
1 couche de colle pour carreaux	- 5 mm
Hauteur (X)	= 85 mm

Hauteur de montage/plancher brut	140 mm
Matelas d'isolation acoustique 17 mm	- 17 mm
Hauteur système de douche* (max.)	- 45 mm
1 couche de colle pour carreaux	- 5 mm
Hauteur (X)	= 73 mm

* Exemple pour système de douche: BF KMK (900 x 900 x 45 mm, tuyau d'écoulement horizontal, centré)

-  Si deve osservare le istruzioni corrispondenti di lavorazione di tutti i mestieri partecipanti.
-  Per l'utilizzazione del materiale d'insonorizzazione in relazione al sistema di doccia Poresta® a fondo piano sono disponibili certificati di controllo del rumore. Per ottenere i livelli sonori d'installazione misurati è necessario di far attenzione alla messa in opera a regola d'arte dei prodotti Poresta® indicati.
-  Evitare il contatto diretto fra pavimento e fondo adiacente e pareti.
-  Per il montaggio è necessario di avere una superficie piana, pulita, stabile ed esente da vibrazioni.
-  Il pavimento nella zona del sistema di doccia deve essere piano (eventualmente correggere con massa d'appianamento).
-  Osservare le istruzioni di montaggio del corrispondente sistema per doccia
-  **1** Posare la stuoia d'isolamento acustico Poresta® senza fissarla.
-  **2** Rimuovere foglio di protezione dal nastro adesivo e coprire stuoie d'isolamento acustico con foglio da costruzione per tutta la superficie.
-  **3** Incollare fasce isolanti di bordo tutt'intorno sul foglio da costruzione.
-  **4** Eventualmente è necessario di accorciare in modo appropriato gli elementi di cassaforma.
-  **5** Dopo l'installazione della rubinetteria di scarico si deve procedere ad una prova di tenuta.
-  **6** Fermare il canale di scolo durante i lavori di riempimento del pavimento.
-  **7** Prima di fermare il canale di scolo, la condotta di scarico deve essere provvista di un rivestimento termoisolante e insonorizzante appropriato (non compreso nella fornitura). Riempire cavità del canale di scolo con pezzi tagliati della stuoia insonorizzante (S).
Non utilizzare la stuoia ad assorbimento acustico per i modelli Poresta® BF 95 e Poresta® Limit S.
-  **8** Le istruzioni di lavorazione ed i tempi d'indurimento indicati dal fabbricante sono da osservare.
-  **9** Supportare l'area di scarico con schiuma di montaggio dei montanti della vasca a Poresta® o con Poresta® Profi Flex.

-  **10** Nell'area della sezione del vaso di scarico applicare sufficiente Poresta® Profi Flex nei quattro angoli. Durante questa operazione, la superficie di tenuta del vaso di scarico non deve essere sporcata!
-  **11** Nell'area della sezione del vaso di scarico applicare sufficiente schiuma di montaggio per supporti vasca Poresta® nei quattro angoli. Durante questa operazione, la superficie di tenuta del vaso di scarico non deve essere sporcata!
-  **12** L'installazione ulteriore dell'elemento di doccia deve essere eseguita in conformità alle istruzioni di montaggio rispettive.

Determinazione dell'altezza dello zoccolo del pavimento a smalto (X ≥ 40 mm):

Altezza di montaggio/pavimento grezzo	140 mm
Stuoia d'isolamento acustico 5 mm	- 5 mm
Altezza sistema di doccia* (max.)	- 45 mm
1 strato di collante da piastrelle	- 5 mm
Altezza (X)	= 85 mm

Altezza di montaggio/pavimento grezzo	140 mm
Stuoia d'isolamento acustico 17 mm	- 17 mm
Altezza sistema di doccia* (max.)	- 45 mm
1 strato di collante da piastrelle	- 5 mm
Altezza (X)	= 73 mm

* Esempio per sistema di doccia: BF KMK (900 x 900 x 45 mm, tubo di scolo orizzontale, centrato)