

AXOR

DE / Gebrauchsanleitung / Montageanleitung	02
FR / Mode d'emploi / Instructions de montage	02
EN / Instructions for use / assembly instructions	03
IT / Istruzioni per l'uso / Istruzioni per l'installazione	03
ES / Modo de empleo / Instrucciones de montaje	04
NL / Gebruiksaanwijzing / Handleiding	04
DK / Brugsanvisning / Monteringsvejledning	05
PT / Instruções para uso / Manual de Instalação	05
PL / Instrukcja obsługi / Instrukcja montażu	06
CS / Návod k použití / Montážní návod	06
SK / Návod na použitie / Montážny návod	07
ZH / 用户手册 / 组装说明	07
RU / Руководство пользователя / Инструкция по монтажу	08
HU / Használati útmutató / Szerelési útmutató	08
FI / Käyttöohje / Asennusohje	09
SV / Bruksanvisning / Monteringsanvisning	09
LT / Vartotojo instrukcija / Montavimo instrukcijos	10
HR / Upute za uporabu / Uputstva za instalaciju	10
TR / Kullanım kılavuzu / Montaj kılavuzu	11
RO / Manual de utilizare / Instrucțiuni de montare	11
EL / Οδηγίες χρήσης / Οδηγία συναρμολόγησης	12
SL / Navodilo za uporabo / Navodila za montažo	12
ET / Kasutusjuhend / Paigaldusjuhend	13
LV / Lietošanas pamācība / Montāžas instrukcija	13
SR / Uputstvo za upotrebu / Uputstvo za montažu	14
NO / Bruksanvisning / Montasjeveiledning	14
BG / Инструкция за употреба / Ръководство за монтаж	15
SQ / Udhëzuesi i përdorimit / Udhëzime rreth montimit	15
AR / دليل الاستخدام / تعليمات التجميع	16

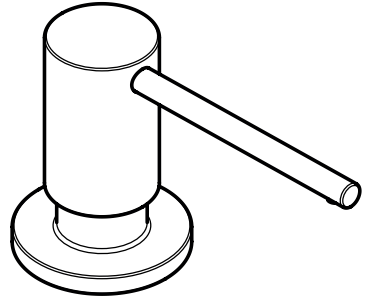

AXOR Uno
42818XXX

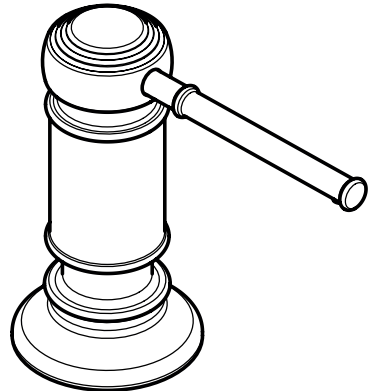

AXOR Montreux
42018XXX



Ihr Online-Fachhändler für:

hansgrohe

- Kostenlose und individuelle Beratung
- Hochwertige Produkte
- Kostenloser und schneller Versand

- TOP Bewertungen
- Exzelerter Kundenservice
- Über 20 Jahre Erfahrung



E-Mail: info@unidomo.de | Tel.: 04621 - 30 60 89 0 | www.unidomo.de

△ SICHERHEITSHINWEISE

- △ Bei der Montage müssen zur Vermeidung von Quetsch- und Schnittverletzungen Handschuhe getragen werden.

MONTAGEHINWEISE

- / Die in den Ländern jeweils gültigen Installationsrichtlinien sind einzuhalten.
- / Vor der Montage muss das Produkt auf Transportschäden untersucht werden. Nach dem Einbau werden keine Transport- oder Oberflächenschäden anerkannt.

SYMBOLERKLÄRUNG

Kein essigsäurehaltiges Silikon verwenden!



MASSE (siehe Seite 18)



SERVICETEILE (siehe Seite 19)

XXX = Farbcodierung

000 = chrom

800 = edelstahl-optik



REINIGUNG (siehe Seite 20)

△ CONSIGNES DE SÉCURITÉ

- △ Lors du montage, porter des gants de protection pour éviter toute blessure par écrasement ou coupure.

INSTRUCTIONS POUR LE MONTAGE

- / Les directives d'installation en vigueur dans le pays concerné doivent être respectées.
- / Avant son montage, s'assurer que le produit n'a subi aucun dommage pendant le transport. Après le montage, tout dommage de transport ou de surface ne pourra pas être reconnu.

DESCRIPTION DU SYMBOLE

Ne pas utiliser de silicone contenant de l'acide acétique!



DIMENSIONS (voir pages 18)



PIÈCES DÉTACHÉES (voir pages 19)

XXX = Couleurs

000 = chromé

800 = aspect acier inox



NETTOYAGE (voir pages 20)

⚠ SAFETY NOTES

- ⚠ Gloves should be worn during installation to prevent crushing and cutting injuries.

INSTALLATION INSTRUCTIONS

- / The plumbing codes applicable in the respective countries must be observed.
- / Prior to installation, inspect the product for transport damages. After it has been installed, no transport or surface damage will be honoured.

SYMBOL DESCRIPTION



Do not use silicone containing acetic acid!



DIMENSIONS (see page 18)



SPARE PARTS (see page 19)

XXX = Colors

000 = chrome plated

800 = stainless steel optic



CLEANING (see page 20)

⚠ INDICAZIONI SULLA SICUREZZA

- ⚠ Durante il montaggio, per evitare ferite da schiacciamento e da taglio bisogna indossare guanti protettivi.

ISTRUZIONI PER IL MONTAGGIO

- / Vanno rispettate le direttive di installazione nazionali vigenti nel rispettivo paese.
- / Prima del montaggio è necessario controllare che non ci siano stati danni durante il trasporto. Una volta eseguito il montaggio, non verranno riconosciuti eventuali danni di trasporto o delle superfici.

DESCRIZIONE SIMBOLO



Non utilizzare silicone contenente acido acetico!



INGOMBRI (vedi pagg. 18)



PARTI DI RICAMBIO (vedi pagg. 19)

XXX = Trattamento

000 = cromato

800 = acciaio inox acciaio



PULITURA (vedi pagg. 20)



△ INDICACIONES DE SEGURIDAD

- △ Durante el montaje deben utilizarse guantes para evitar heridas por aplastamiento o corte.

INDICACIONES PARA EL MONTAJE

- / Es obligatorio el cumplimiento de las directrices de instalación vigentes en el país respectivo.
- / Antes del montaje se debe examinarse el producto contra daños de transporte. Después de la instalación no se reconoce ningún daño de transporte o de superficie.

DESCRIPCIÓN DE SÍMBOLOS



No utilizar silicona que contiene ácido acético!



DIMENSIONES (ver página 18)



REPUESTOS (ver página 19)

XXX = Acabados

000 = cromado

800 = acero especial



LIMPIAR (ver página 20)

△ VEILIGHEIDSINSTRUCTIES

- △ Bij de montage moeten ter voorkoming van knel- en snijwonden handschoenen worden gedragen.

MONTAGE-INSTRUCTIES

- / De in de overeenkomstige landen geldende installatie-richtlijnen moeten nageleefd worden.
- / Vóór de montage moet het product gecontroleerd worden op transportschade. Na de inbouw wordt geen transport- of oppervlakteschade meer aanvaard.

SYMBOOLBESCHRIJVING



Gebruik geen zuurhoudende siliconen!



MATEN (zie blz. 18)



SERVICE
ONDERDELEN (zie blz. 19)

XXX = Kleuren

000 = verchromd

800 = RVS-look



REINIGEN (zie blz. 20)

⚠ SIKKERHEDSANVISNINGER

- ⚠ Ved monteringen skal der bruges handsker for at undgå kvæstelser og snitsår.

MONTERINGSANVISNINGER

- / Installationsbestemmelserne, der gælder i det enkelte land, skal overholdes.
- / Før monteringen skal produktet kontrolleres for transportkader. Efter monteringen godkendes transportskader eller skader på overfladen ikke længere.

SYMBOLBESKRIVELSE



Der må ikke benyttes eddikesyreholdig silikone!



MÅLENE (se s. 18)



RESERVEDELE (se s. 19)

XXX = Overflade

000 = Krom

800 = Stainless steel optic



RENGØRING (se s. 20)

⚠ AVISOS DE SEGURANÇA

- ⚠ Durante a montagem devem ser utilizadas luvas de protecção, de modo a evitar ferimentos resultantes de entalamentos e de cortes.

AVISOS DE MONTAGEM

- / A prescrições de instalação válidas nos respetivos países devem ser respeitadas.
- / Antes da montagem deve-se controlar o produto relativamente a danos de transporte. Após a montagem não são aceites quaisquer danos de transporte ou de superfície.

DESCRIÇÃO DO SÍMBOLO



Não utilizar silicone que contenha ácido acético!



MEDIDAS (ver página 18)



PEÇAS DE SUBSTITUIÇÃO (ver página 19)

XXX = Acabamentos

000 = cromado

800 = aço imaculado ótica



LIMPEZA (ver página 20)

⚠ WSKAZÓWKI BEZPIECZEŃSTWA

- ⚠ Aby uniknąć zranień na skutek zgniecenia lub przecięcia, podczas montażu należy nosić rękawice ochronne.

WSKAZÓWKI MONTAŻOWE

- / Należy przestrzegać wytycznych instalacyjnych obowiązujących w danym kraju.
- / Przed montażem należy skontrolować produkt pod kątem szkód transportowych. Po montażu nie widać żadnych szkód transportowych ani szkód na powierzchni.

OPIS SYMBOLU



Nie stosować silikonów zawierających kwas octowy!



WYMIARY (patrz strona 18)



CZĘŚCI SERWISOWE-
(patrz strona 19)

XXX = Kody kolorów

000 = chrom

800 = stal szlachetna



CZYSZCZENIE (patrz strona 20)

⚠ BEZPEČNOSTNÍ POKYNY

- ⚠ Pro zabránění řezným zraněním a pohmožděninám je nutné při montáži nosit rukavice.

POKYNY K MONTÁŽI

- / Je třeba dodržovat montážní pravidla platné v dané zemi.
- / Před montáží je třeba produkt zkontrolovat, zda nebyl při transportu poškozen. Po zabudování nebudou uznány žádné škody způsobené transportem nebo poškození povrchu.

POPIS SYMBOLŮ



Nepoužívat silikon s obsahem kyseliny octové!



ROZMĚRY (viz strana 18)



SERVISNÍ DÍLY (viz strana 19)

XXX = Kód povrchové úpravy

000 = chrom

800 = nerezová ocel



ČIŠTĚNÍ (viz strana 20)

△ BEZPEČNOSTNÉ POKYNY

△ Pri montáži musíte nosiť rukavice, aby ste predišli pomliaždeninám a rezným poraneniam.

POKYNY PRE MONTÁŽ

- / Je potrebné dodržiavať smernice o inštalácii, ktoré sú práve teraz platné v krajinách.
- / Pred montážou musíte produkt skontrolovať, či nebol počas transportu poškodený. Po zabudovaní nebudú uznané žiadne škody spôsobené transportom alebo poškodenia povrchu.

POPIS SYMBOLOV



Nepoužívať silikón s obsahom kyseliny octovej!



ROZMERY (viď strana 18)



SERVISNÉ DIELY (viď strana 19)

XXX = Farebné označenie

000 = chróm

800 = ušľachtilá oceľ



ČISTENIE (viď strana 20)

△ 安全技巧

△ 装配时为避免挤压和切割受伤，必须戴上手套。

安装提示

- / 请遵守当地国家现行的安装规定。
- / 安装前必须检查产品是否受到运输损害。安装后将不认可运输损害或表面损伤。

符号说明



请勿使用含有乙酸的硅胶！



大小 (参见第 18 页)



备用零件 (参见第 19 页)

XXX = 颜色代码

000 = 镀铬

800 = 不锈钢表面



清洗 (参见第 20 页)

⚠ УКАЗАНИЯ ПО ТЕХНИКЕ БЕЗОПАСНОСТИ

- ⚠ Во время монтажа следует надеть перчатки во избежание прищемления и порезов.

УКАЗАНИЯ ПО МОНТАЖУ

- / Необходимо соблюдать требования по монтажу, действующие в соответствующих странах.
- / Перед монтажом следует проверить изделие на предмет повреждений при перевозке. После монтажа претензии о возмещении ущерба за повреждения при перевозке или повреждения поверхностей не принимаются.

ОПИСАНИЕ СИМВОЛОВ



Не применяйте силикон, содержащий уксусную кислоту.



РАЗМЕРЫ (см. стр. 18)



КОМПЛЕКТ (см. стр. 19)

XXX = Цветная кодировка

000 = хром

800 = сталь



ОЧИСТКА (см. стр. 20)

⚠ BIZTONSÁGI UTASÍTÁSOK

- ⚠ A szerelésnél a zúzódások és vágási sérülések elkerülése érdekében kesztyűt kell viselni.

SZERELÉSI UTASÍTÁSOK

- / Az egyes országokban érvényes installációs irányelveket be kell tartani.
- / A szerelés előtt ellenőrizni kell, hogy a terméknek nincs-e szállítási sérülése. Beépítés után a szállítási- vagy felületi sérüléseket nem ismerik el.

SZIMBÓLUMOK LEÍRÁSA



Ne használjon ecetsavtartalmú szilikon!



MÉRETET (lásd a oldalon 18)



TARTOZÉKOK (lásd a oldalon 19)

XXX = Szinkódolás

000 = króm

800 = acélopitka



TISZTÍTÁS (lásd a oldalon 20)



△ TURVALLISUUSOHJEET

△ Asennuksessa on käytettävä käsineitä puristumien ja viiltojen aiheuttamien tapaturmien estämiseksi.

ASENNUSOHJEET

- / Jokaisessa maassa on noudatettava siellä päteviä asennusohjeita.
- / Ennen asennusta on tarkastettava tuotteen mahdolliset kuljetusvahingot. Asennuksen jälkeen kuljetus- ja pintavaurioita ei hyväksytä.

MERKIN KUVAUS



Älä käytä etikkahappopitoista silikonial



MITAT (katso sivu 18)



VARAOSAT (katso sivu 19)

XXX = Värikoodaus

000 = kromi

800 = inox-optinen



PUHDISTUS (katso sivu 20)

△ SÄKERHETSANVISNINGAR

△ Handskar ska bäras under monteringsarbetet så att man kan undvika kläm- och skärskadorgen werden.

MONTERINGSANVISNINGAR

- / De installationsriktlinjer som gäller i länderna ska följas.
- / Det måste undersökas om produkten har transportskador innan den monteras. Efter monteringen accepteras inga transport- eller ytskiktsskador.

SYMBOLFÖRKLARING



Använd inte silikon som innehåller ättiksyra!



MÅTTEN (se sidan 18)



RESERVDELAR (se sidan 19)

XXX = Färgkodning

000 = krom

800 = rostfri-optik



RENGÖRING (se sidan 20)



⚠ SAUGUMO TECHNIKOS NURODYMAI

⚠ Apsaugai nuo užspaudimo ir įsijovimo montavimo metu mūvėkite pirštines.

MONTAVIMO INSTRUKCIJA

- / Laikykitės atitinkamoje šalyje galiojančių direktyvų dėl įrengimo.
- / Prieš montuojant būtina patikrinti, ar gaminys nebuvo pažeistas transportavimo metu. Sumontavus pretenzijos dėl transportavimo ir paviršiaus pažeidimų nepriimamos.

SIMBOLIO APRAŠYMAS



Nenaudokite silikonu, kurio sudėtyje yra acto rūgšties!



IŠMATAVIMAI (žr. psl. 18)



ATSARGINĖS DALYS (žr. psl. 19)

XXX = Spalvos

000 = chrom

800 = plienas



VALYMAS (žr. psl. 20)

⚠ SIGURNOSNE UPUTE

⚠ Prilikom montaže se radi sprječavanja prignječenja i posjekotina moraju nositi rukavice.

UPUTE ZA MONTAŽU

- / Obvezno se moraju uvažiti propisi o instalacijama koji vrijede u dotičnoj zemlji.
- / Prije montaže mora se provjeriti je li proizvod oštećen prilikom transporta. Nakon ugradnje se ne priznaju nikakve reklamacije koje se odnose na površinska i transportna oštećenja.

OPIS SIMBOLA



Nemojte koristiti silikon koji sadrži octenu kiselinu!



MJERE (pogledaj stranicu 18)



REZERVNI

DJELOVI (pogledaj stranicu 19)

XXX = Boje

000 = krom

800 = plemeniti čelik



ČIŠĆENJE (pogledaj stranicu 20)



⚠ GÜVENLİK UYARILARI

- ⚠ Montaj esnasında ezilme ve kesilme gibi yaralanmaları önlemek için eldiven kullanılmalıdır.

MONTAJ AÇIKLAMALARI

- / Ülkelerde geçerli kurulum yönetmeliklerine riayet edilmelidir.
- / Montaj işleminden önce ürün nakliye hasarları yönünden kontrol edilmelidir. Montaj işleminden sonra nakliye veya yüzey hasarları için sorumluluk üstlenilmemektedir.

SİMGE AÇIKLAMASI



Asetik asit içeren silikon kullanmayın!



ÖLÇÜLERİ (bakınız sayfa 18)



YEDEK PARÇALAR (bakınız sayfa 19)

XXX = Renkler

000 = krom

800 = paslanmaz çelik - optik



TEMİZLEME (bakınız sayfa 20)

⚠ INSTRUCȚIUNI DE SIGURANȚĂ

- ⚠ La montare utilizați mănuși pentru evitarea contuziunilor și tăierii mâinilor.

INSTRUCȚIUNI DE MONTARE

- / Respectați reglementările referitoare la instalare valabile în țara respectivă.
- / Înainte de instalare verificați, dacă produsul prezintă deteriorări de transport. După instalare garanția nu acoperă deteriorările de transport și cele de suprafață.

DESCRIEREA SIMBOLURILOR



Nu utilizați silicon cu conținut de acid acetic!



DIMENSIUNI (vezi pag. 18)



PIESE DE SCHIMB (vezi pag. 19)

XXX = Coduri de culori

000 = crom

800 = oțel inox



CURĂȚARE (vezi pag. 20)



⚠ ΥΠΟΔΕΙΞΕΙΣ ΑΣΦΑΛΕΙΑΣ

⚠ Για να αποφύγετε τραυματισμούς κατά τη συναρμολόγηση πρέπει να φοράτε γάντια.

ΟΔΗΓΙΕΣ ΣΥΝΑΡΜΟΛΟΓΗΣΗΣ

- / Θα πρέπει να τηρούνται οι οδηγίες εγκατάστασης που ισχύουν σε κάθε κράτος.
- / Πριν τη συναρμολόγηση πρέπει να εξεταστεί το προϊόν για ζημιές μεταφοράς. Μετά την εγκατάσταση δεν αναγνωρίζονται ζημιές από τη μεταφορά ή επιφανειακές ζημιές.

ΠΕΡΙΓΡΑΦΗ ΣΥΜΒΟΛΩΝ



Μην χρησιμοποιείτε σιλικόνη που περιέχει οξικό οξύ!



ΔΙΑΣΤΑΣΕΙΣ (βλ. Σελίδα 18)



ΑΝΤΑΛΛΑΚΤΙΚΑ (βλ. Σελίδα 19)

XXX = Χρώματα

000 = Επιχρωμωμένο

800 = οπτική ανοξείδωτου χάλυβα



ΚΑΘΑΡΙΣΜΟΣ (βλ. Σελίδα 20)

⚠ VARNOSTNA OPOZORILA

⚠ Pri montaži je treba nositi rokavice, da se preprečijo poškodbe zaradi zmečkanja ali urezov.

NAVODILA ZA MONTAŽO

- / Upoštevati je treba pravilnike o inštalacijah, ki veljajo v posamezni državi.
- / Pred montažo je treba izdelek preveriti glede morebitnih transportnih poškodb. Po vgradnji transportne ali površinske poškodbe ne bodo več priznane.

OPIS SIMBOLA



Ne smete uporabiti silikona, ki vsebuje ocatno kislino!



MERE (glejte stran 18)



REZERVNI DELI (glejte stran 19)

XXX = Barve

000 = krom

800 = videz legiranega jekla



ČIŠČENJE (glejte stran 20)

△ OHUTUSJUHISED

△ Kandke paigaldamisel muljumis- ja löikevigastuste vältimiseks kindaid.

PAIGALDAMISJUHISED

- / Vastavas riigis kehtivaid paigalduseeskirju tuleb järgida.
- / Enne paigaldamist tuleb toodet kontrollida transportikahjustuste osas. Pärast paigaldamist ei tunnustata enam transporti- või pinnakahjustuste kaebuseid.

SÜMBOLITE KIRJELDUS



Ärge kasutage äädikhapet sisaldavat silikooni!



MÕÕTUDE (vt lk 18)



VARUOSAD (vt lk 19)

XXX = Värvid

000 = kroom

800 = roostevaba optik



PUHASTAMINE (vt lk 20)

△ DROŠĪBAS NORĀDES

△ Montāžas laikā, lai izvairītos no saspiedumiem un iegriezumiem, nepieciešams nēsāt cimdus.

NORĀDĪJUMI MONTĀŽAI

- / Jāievēro attiecīgās valstīs spēkā esošās montāžas prasības.
- / Pirms montāžas nepieciešams pārbaudīt, vai produktam transportēšanas laikā nav radušies bojājumi. Pēc iebūvēšanas bojājumi, kas radušies transportēšanas laikā, vai virsmas bojājumi netiek atzīti.

SIMBOLU NOZĪME



Neizmantojot silikonu, kas satur etiķskābi!



IZMĒRUS (skat. lpp. 18)



REZERVES DAĻAS (skat. lpp. 19)

XXX = Krāsu kodi

000 = hroma

800 = tērauda



TĪRĪŠANA (skat. lpp. 20)

⚠ SIGURNOSNE NAPOMENE

- ⚠ Prilikom montaže se radi sprečavanja prignječenja i posekotina moraju nositi rukavice.

INSTRUKCIJE ZA MONTAŽU

- / Treba se pridržavati propisa koji u određenim zemljama važe za instalacije.
- / Pre montaže se mora proveriti da li je proizvod oštećen pri transportu. Nakon ugradnje se ne priznaju nikakve reklamacije koje se odnose na površinska i transportna oštećenja.

OPIS SIMBOLA



Nemojte koristiti silikon koji sadrži sirćetnu kiselinu!



MERE (vidi stranu 18)



REZERVNI DELOVI (vidi stranu 19)

XXX = Oznake boja

000 = hrom

800 = dezen plemeniti čelik



ČIŠĆENJE (vidi stranu 20)

⚠ SIKKERHETSHENVISNINGER

- ⚠ Bruk hansker under montasjen for å unngå klem- og kuttskader.

MONTAGEHENVISNINGER

- / Gjeldende retningslinjer for rørleggerarbeid i de enkelte land skal følges.
- / Før montasjen skal produktet sjekkes for transportska- der. Etter monteringen aksepteres ikke noen transport- eller overflateskader.

SYMBOLBESKRIVELSE



Ikke bruk silikon som inneholder eddiksyre!



MÅL (se side 18)



SERVICEDELER (se side 19)

XXX = Fargekode

000 = krom

800 = rustfritt stål optikk



RENGJØRING (se side 20)

⚠ УКАЗАНИЯ ЗА БЕЗОПАСНОСТ

- ⚠ При монтажа трябва да се носят ръкавици, за да се избегнат наранявания поради притискане или порязване.

УКАЗАНИЯ ЗА МОНТАЖ

- / Трябва да бъдат спазвани валидните в съответните страни предписания за инсталиране.
- / Преди монтажа продуктът трябва да се провери за транспортни щети. След монтажа не се признават транспортни или повърхностни щети.

ОПИСАНИЕ НА СИМВОЛИТЕ



Не използвайте силикон, съдържащ оцетна киселина!



РАЗМЕРИ (вижте стр. 18)



СЕРВИЗНИ ЧАСТИ (вижте стр. 19)

XXX = Цветово кодиране

000 = хром

800 = оптика на благородна стомана



ПОЧИСТВАНЕ (вижте стр. 20)

⚠ UDHËZIME SIGURIE

- ⚠ Për të evituar lëndimet e pickimeve ose të prerjeve gjatë procesit të montimit duhet që të vishni doreza.

UDHËZIME PËR MONTIMIN

- / Duhet të respektohen linjat udhëzuese të instalimit, të vlefshme për vendet respektive.
- / Përpara montimit duhet që produkti të kontrollohet për dëmtime nga transporti. Pas instalimit nuk do të njihet asnjë dëmtim nga transporti ose dëmtim i sipërfaqes.

PËRSHKRIMI I SIMBOLIT



Mos përdorni silikon që në përbërje ka acid acetik.



PËRMASAT (shih faqen 18)



PJESËT E SERVISIT (shih faqen 19)

XXX = Kodimi me anë të ngjyrave

000 = krom

800 = optikë çeliku



PASTRIMI (shih faqen 20)



⚠ تنبيهات الأمان

⚠ يجب إرتداء قفازات لليد أثناء التركيب لتجنب حدوث أخطار الإنحشار أو الحروق.

تعليمات التركيب

/ يجب مراعاة القواعد الخاصة بالتركيب وأعمال السباكة وفقاً للوائح الخاصة بكل بلد.

/ قبل القيام بعملية التركيب، يجب فحص المنتج للتأكد من خلوه من أية تلفيات ناتجة عن النقل. بعد القيام بعملية التركيب، لن يتم الاعتراف بوجود أية تلفيات سطحية أو تلفيات ناتجة عن عملية النقل.

وصف الرمز

هام! لا تستخدم السليكون الذي يحتوي على أحماض! 

أبعاد (راجع صفحة 18) 

قطع الغيار (راجع صفحة 19) 

XXX = الألوان

000 = كروم

800 = مظهر الإستنليس ستيل

التنظيف (راجع صفحة 20) 

التركيب (راجع صفحة 17) 

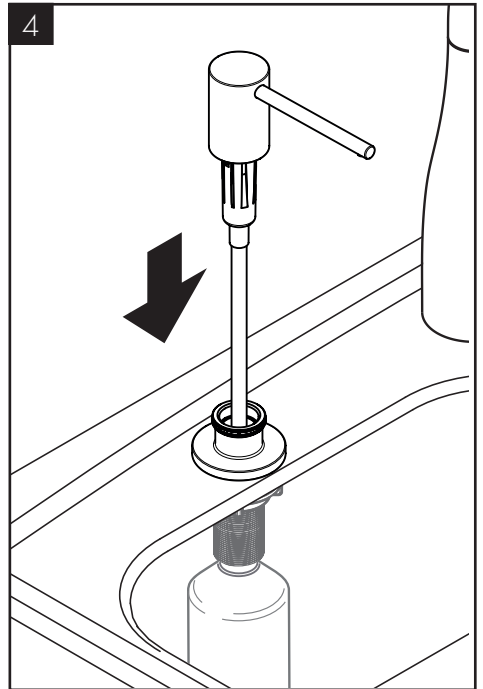
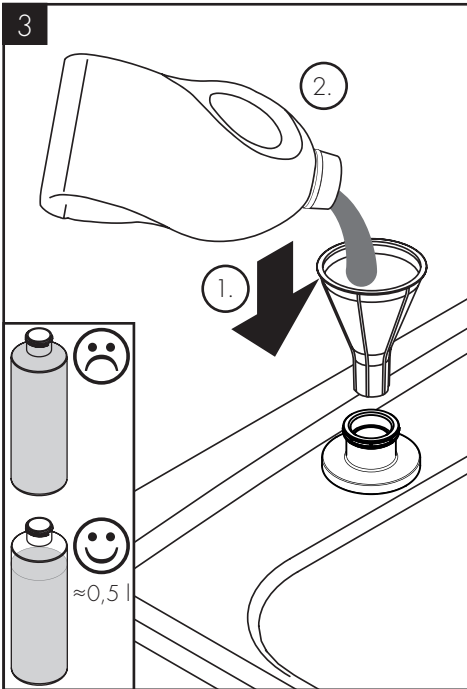
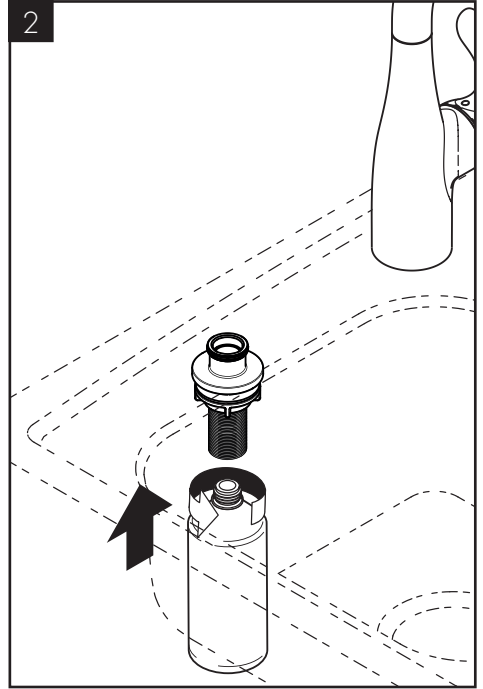
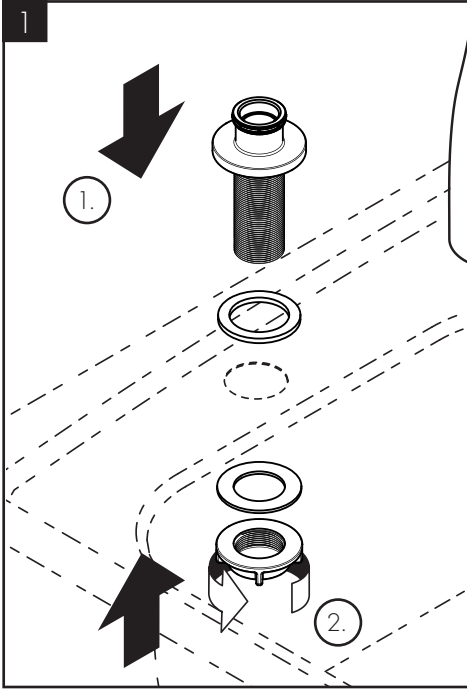



AXOR Montreux
42018XXX

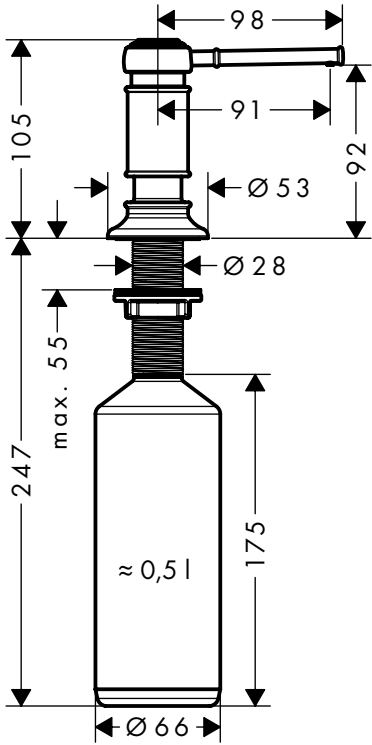

AXOR Uno
42818XXX

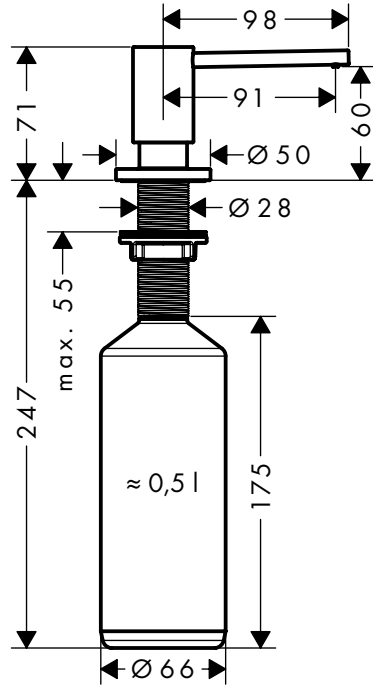

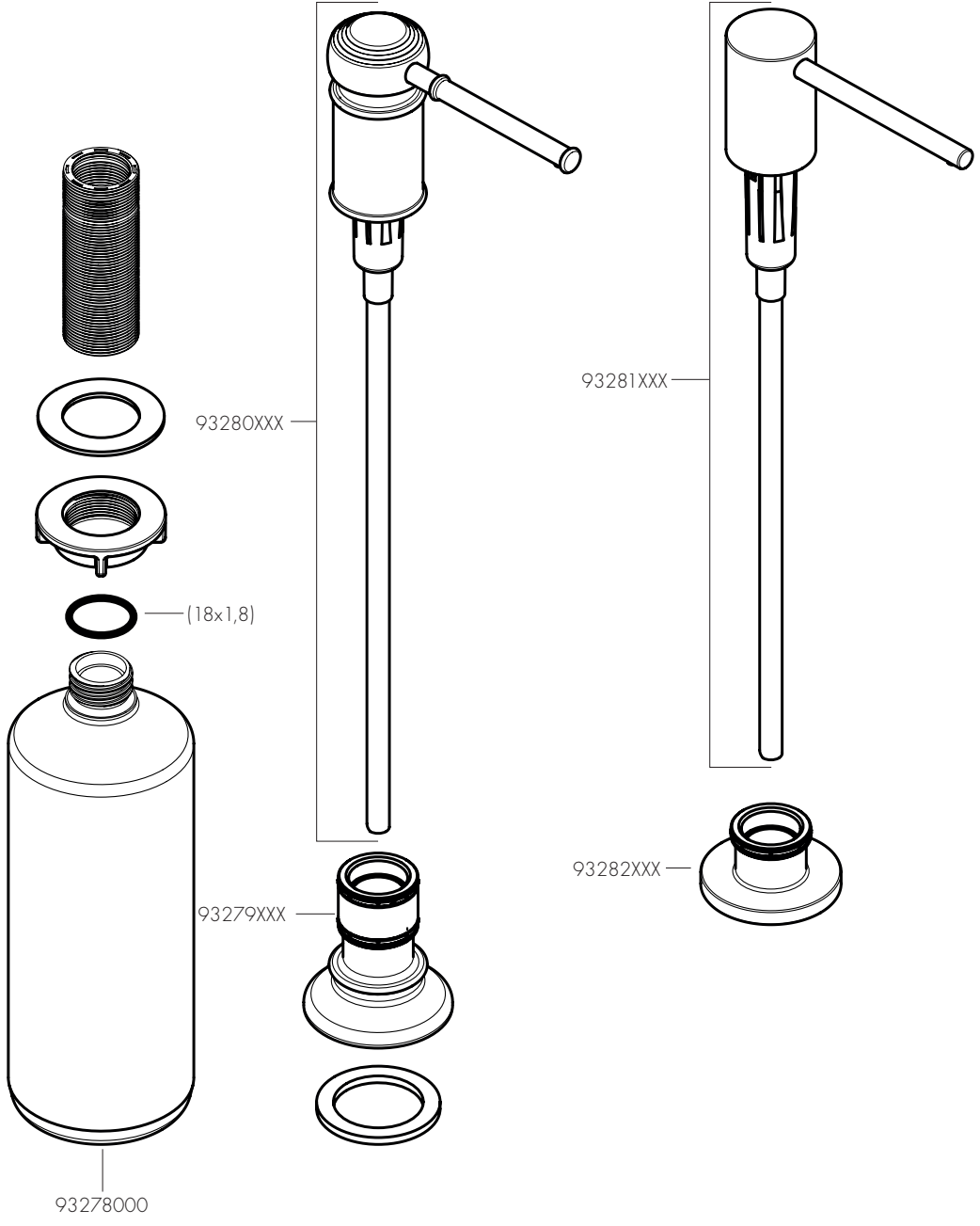



- DE / Reinigungsempfehlung / Garantie / Kontakt
 FR / Recommandation pour le nettoyage / Garanties / Contact
 EN / Cleaning recommendation / Warranty / Contact
 IT / Raccomandazione di pulizia / Garanzia / Contatto
 ES / Recomendaciones para la limpieza / Garantía / Contacto
 NL / Aanbevelingen inzake reiniging / Garantie / Contact
 DK / Rensning, anbefaling / Garanti / Kontakt
 PT / Recomendações de limpeza / Garantia / Contacto
 PL / Zalecenie dotyczące pielęgnacji / Gwarancja / Kontakt
 CS / Doporučení k čištění / Záruka / Kontakt
 SK / Odporúčania pre čistenie / Záruka / Kontakt
 ZH / 清洁指南 / 担保 / 接触
 RU / Рекомендации по очистке / Гарантия / Контакты
 HU / Tisztítási tanácsok / Garancia / érintkezés
 FI / Puhdistussuositus / Takuu / Kosketus
 SV / Rengöringsrekommendationer / Garanti / Contacto
 LT / Valymo rekomendacijos / Garantija / Kontaktai
 HR / Preporuke za čišćenje / Garancija / Kontakt
 TR / Temizleme önerisi / Garanti / Temas
 RO / Recomandări pentru curățare / Garanție / Contact
 EL / Σύσταση καθαρισμού / Εγγύηση / επαφή
 SL / Priporočilo za čišćenje / Garancija / Kontakt
 ET / Puhastussuovitused / Garantii / Kontakt
 LV / Tīrīšanas ieteikumi / Garantija / Kontakti
 SR / Preporuke za čišćenje / Garancija / Kontakt
 NO / Anbefaling for rengjøring / Garanti / Kontakt
 BG / Препоръка за почистване / Гаранция / Контакт
 SQ / Këshilla rreth pastrimit / Garancia / Kontakt
 KO / 세정시 권장사항 / 품질보증 / 접촉
 AR / توصيات التنظيف / الضمان (الولايات المتحدة الأمريكية) / اتصال



[www.axor-design.com/
cleaning-recommendation](http://www.axor-design.com/cleaning-recommendation)

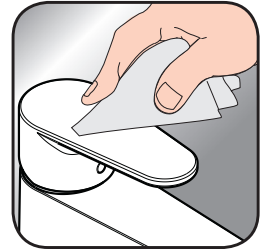

[www.axor-design.com/
cleaning-recommendation](http://www.axor-design.com/cleaning-recommendation)



[www.axor-design.com/
cleaning-recommendation](http://www.axor-design.com/cleaning-recommendation)



[www.axor-design.com/
cleaning-recommendation](http://www.axor-design.com/cleaning-recommendation)

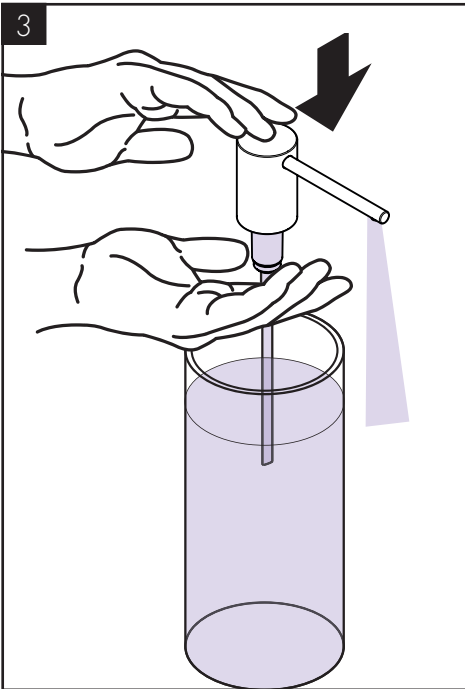
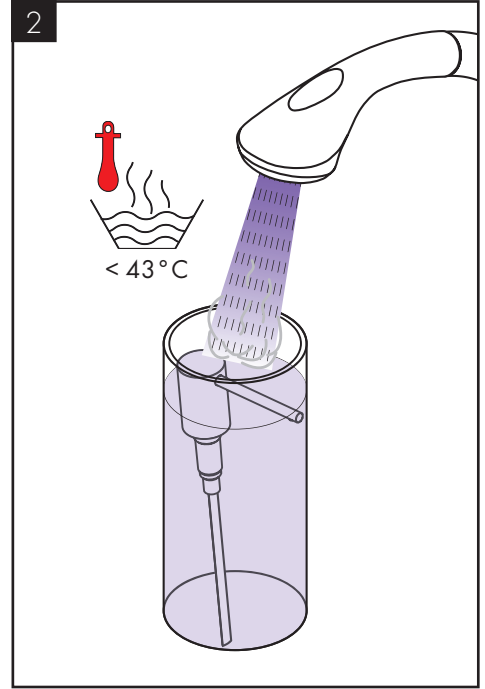
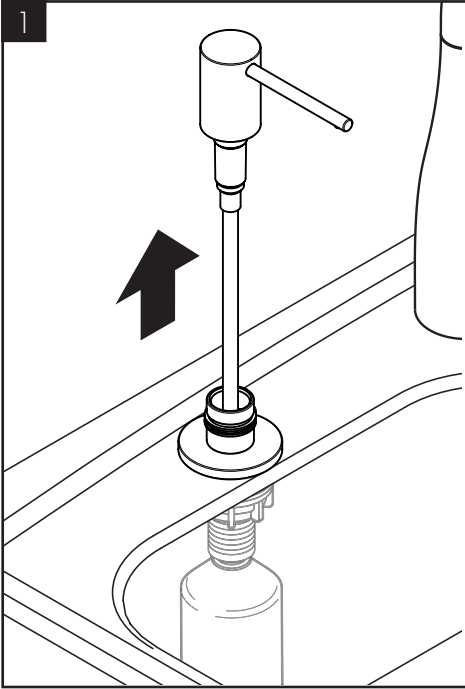

AXOR

AXOR / Hansgrohe SE
Austraße 5-9
77761 Schiltach
Deutschland

info@axor-design.com
axor-design.com

8/2018
9.06358.01