



**UNIDOMO®**

**Web:** [www.unidomo.de](http://www.unidomo.de)

**Telefon:** 04621- 30 60 89 0

**Mail:** [info@unidomo.com](mailto:info@unidomo.com)

**Öffnungszeiten:** Mo.-Fr. 8:00-17:00 Uhr

**VIESMANN**

**Buderus**

 **Vaillant**

**WOLF**

 **JUNKERS**  **BOSCH**

 **remeha**

 **DAIKIN**

**ROTEX**

a member of DAIKIN group



-  Individuelle Beratung
-  Kostenloser Versand
-  Hochwertige Produkte

-  Komplettpakete
-  Über 15 Jahre Erfahrung
-  Markenhersteller

# AXOR

DE / Gebrauchsanleitung / Montageanleitung	02
EN / Instructions for use / assembly instructions	02
FR / Mode d'emploi / Instructions de montage	02
IT / Istruzioni per l'uso / Istruzioni per l'installazione	02
ES / Modo de empleo / Instrucciones de montaje	03
DK / Brugsanvisning / Monteringsvejledning	03
NL / Gebruiksaanwijzing / Handleiding	03
PT / Instruções para uso / Manual de instalação	03
PL / Instrukcja obsługi / Instrukcja montażu	04
SK / Návod na použitie / Montážny návod	04
CS / Návod k použití / Montážní návod	04
ZH / 用户手册 / 组装说明	04
RU / Руководство пользователя / Инструкция по монтажу	05
FI / Käyttöohje / Asennusohje	05
HU / Használati útmutató / Szerelési útmutató	05
SV / Bruksanvisning / Monteringsanvisning	05
LT / Vartotojo instrukcija / Montavimo instrukcijos	06
TR / Kullanım kılavuzu / Montaj kılavuzu	06
HR / Upute za uporabu / Uputstva za instalaciju	06
RO / Manual de utilizare / Instrucțiuni de montare	06
EL / Οδηγίες χρήσης / Οδηγία συναρμολόγησης	07
ET / Kasutusjuhend / Paigaldusjuhend	07
SL / Navodilo za uporabo / Navodila za montažo	07
LV / Lietošanas pamācība / Montāžas instrukcija	07
SR / Uputstvo za upotrebu / Uputstvo za montažu	08
BG / Инструкция за употреба / Ръководство за монтаж	08
NO / Bruksanvisning / Montasjeveiledning	08
SQ / Udhëzuesi i përdorimit / Udhëzime rreth montimit	08
AR / دليل الاستخدام / تعليمات التجميع	09

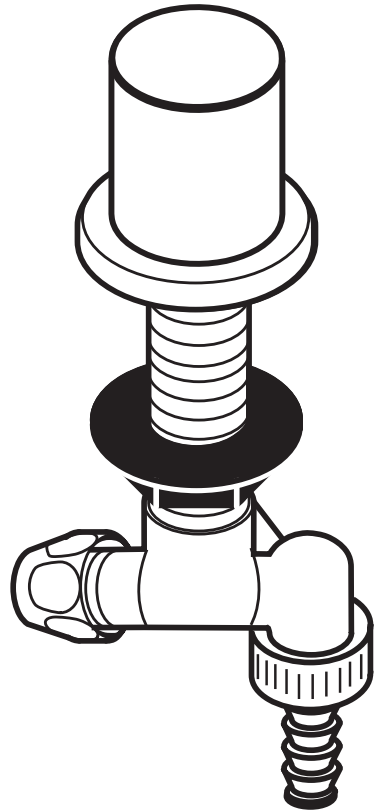

AXOR Starck  
10823000 / 10823800

INSTALLATION

## TECHNISCHE DATEN

Durchflussleistung bei 0,3 MPa:	12,5 l/min
Betriebsdruck:	max. 1 MPa
Empfohlener Betriebsdruck:	0,1 - 0,5 MPa
Prüfdruck:	1,6 MPa
	(1 MPa = 10 bar = 147 PSI)
Heißwassertemperatur:	max. 70°C
Empfohlene Heißwassertemperatur:	65°C

## SYMBOLERKLÄRUNG



Kein essigsäurehaltiges Silikon verwenden!



MASSE (siehe Seite 11)



SERVICETEILE (siehe Seite 11)



REINIGUNG (siehe Seite 12)

MONTAGE (siehe Seite 10) 

## EN

## TECHNICAL DATA

Rate of flow by 0,3 MPa:	12,5 l/min
Operating pressure:	max. 1 MPa
Recommended operating pressure:	0,1 - 0,5 MPa
Test pressure:	1,6 MPa
	(1 MPa = 10 bar = 147 PSI)
Hot water temperature:	max. 70°C
Recommended hot water temp.:	65°C

## SYMBOL DESCRIPTION



Do not use silicone containing acetic acid!



DIMENSIONS (see page 11)



SPARE PARTS (see page 11)



CLEANING (see page 12)

ASSEMBLY (see page 10) 

## INFORMATIONS TECHNIQUES

Débit à 0,3 MPa:	12,5 l/min
Pression de service autorisée:	max. 1 MPa
Pression de service conseillée:	0,1 - 0,5 MPa
Pression maximum de contrôle:	1,6 MPa
	(1 MPa = 10 bar = 147 PSI)
Température d'eau chaude:	max. 70°C
Température recommandée:	65°C

## DESCRIPTION DU SYMBOLE



Ne pas utiliser de silicone contenant de l'acide acétique!



DIMENSIONS (voir pages 11)



PIÈCES DÉTACHÉES (voir pages 11)



NETTOYAGE (voir pages 12)

MONTAGE (voir pages 10) 

## IT

## DATI TECNICI

Potenza di erogazione a 0,3 MPa:	12,5 l/min
Pressione d'uso:	max. 1 MPa
Pressione d'uso consigliata:	0,1 - 0,5 MPa
Pressione di prova:	1,6 MPa
	(1 MPa = 10 bar = 147 PSI)
Temperatura dell'acqua calda:	max. 70°C
Temp. dell'acqua calda consigliata:	65°C

## DESCRIZIONE SIMBOLO



Non utilizzare silicone contenente acido acetico!



INGOMBRI (vedi pagg. 11)



PARTI DI RICAMBIO  
(vedi pagg. 11)



PULITURA (vedi pagg. 12)

MONTAGGIO (vedi pagg. 10) 

## DATOS TÉCNICOS

Caudal a 0,3 MPa:	12,5 l/min
Presión en servicio:	max. 1 MPa
Presión recomendada en servicio:	0,1 - 0,5 MPa
Presión de prueba:	1,6 MPa
	(1 MPa = 10 bar = 147 PSI)
Temperatura del agua caliente:	max. 70°C
Temp. recomendada del agua caliente:	65°C

## TECHNISCHE GEGEVENS

Doorvoercapaciteit bij 0,3 MPa:	12,5 l/min
Werkdruk: max.	max. 1 MPa
Aanbevolen werkdruk:	0,1 - 0,5 MPa
Getest bij:	1,6 MPa
	(1 MPa = 10 bar = 147 PSI)
Temperatuur warm water:	max. 70°C
Aanbevolen warm water temp.:	65°C

## DESCRIPCIÓN DE SÍMBOLOS



No utilizar silicona que contiene ácido acético!



DIMENSIONES (ver página 11)



REPUESTOS (ver página 11)



LIMPIAR (ver página 12)

MONTAJE (ver página 10)



## SYMBOOLBESCHRIJVING



Gebruik geen zuurhoudende siliconel



MATEN (zie blz. 11)



SERVICE ONDERDELEN  
(zie blz. 11)



REINIGEN (zie blz. 12)

MONTAGE (zie blz. 10)



## TEKNISKE DATA

Gennemstrømningsydelse ved 0,3 MPa:	12,5 l/min
Driftstryk:	max. 1 MPa
Anbefalet driftstryk:	0,1 - 0,5 MPa
Prøvetryk:	1,6 MPa
	(1 MPa = 10 bar = 147 PSI)
Varmtvandstemperatur:	max. 70°C
Anbefalet varmtvandstemperatur:	65°C

## DADOS TÉCNICOS

Caudal o 0,3 MPa:	12,5 l/min
Pressão de funcionamento:	max. 1 MPa
Pressão de func. recomendada:	0,1 - 0,5 MPa
Pressão testada:	1,6 MPa
	(1 MPa = 10 bar = 147 PSI)
Temperatura da água quente:	max. 70°C
Temp. água quente recomendada:	65°C

## SYMBOLBESKRIVELSE



Der må ikke benyttes eddikesyreholdig silikonel



MÅLENE (se s. 11)



RESERVEDELE (se s. 11)



RENGØRING (se s. 12)

MONTERING (se s. 10)



## DESCRIÇÃO DO SÍMBOLO



Não utilizar silicone que contenha ácido acético!



MEDIDAS (ver página 11)



PEÇAS DE SUBSTITUIÇÃO  
(ver página 11)



LIMPEZA (ver página 12)

MONTAGEM (ver página 10)



## DANE TECHNICZNE

Wydajność przepływu przy 0,3 MPa:	12,5 l/min
Ciśnienie robocze:	maks. 1 MPa
Zalecane ciśnienie robocze:	0,1 - 0,5 MPa
Ciśnienie próbne:	1,6 MPa
	(1 MPa = 10 bary = 147 PSI)
Temperatura wody gorącej:	maks. 70°C
Zalecana temperatura wody gorącej:	65°C

## OPIS SYMBOLU



Nie stosować silikonów zawierających kwas octowy!



WYMIARY (patrz strona 11)



CZĘŚCI SERWISOWE  
(patrz strona 11)



CZYSZCZENIE (patrz strona 12)

MONTAŻ (patrz strona 10) 

## SK

## TECHNICKÉ ÚDAJE

Prietokové množstvo pri 0,3 MPa:	12,5 l/min
Prevádzkový tlak:	max. 1 MPa
Doporučený prevádzkový tlak:	0,1 - 0,5 MPa
Skúšobný tlak:	1,6 MPa
	(1 MPa = 10 bar = 147 PSI)
Teplota teplej vody:	max. 70°C
Doporučená teplota teplej vody:	65°C

## POPIS SYMBOLOV



Nepoužívať silikon s obsahom kyseliny octovej!



ROZMERY (viď strana 11)



SERVISNÉ DIELY (viď strana 11)



ČISTENIE (viď strana 12)

MONTÁŽ (viď strana 10) 

## TECHNICKÉ ÚDAJE

Průtokové množství při 0,3 MPa:	12,5 l/min
Provozní tlak:	max. 1 MPa
Doporučený provozní tlak:	0,1 - 0,5 MPa
Zkušební tlak:	1,6 MPa
	(1 MPa = 10 bar = 147 PSI)
Teplota horké vody:	max. 70°C
Doporučená teplota horké vody:	65°C

## POPIS SYMBOLŮ



Nepoužívat silikon s obsahem kyseliny octové!



ROZMĚRY (viz strana 11)



SERVISNÍ DÍLY (viz strana 11)



ČIŠTĚNÍ (viz strana 12)

MONTÁŽ (viz strana 10) 

## ZH

## 技术参数

流量 0,3 MPa:	12,5 升/分钟
工作压力:	最大 1 MPa
推荐工作压力:	0,1 - 0,5 MPa
测试压强:	1,6 MPa
	(1 MPa = 10 bar = 147 PSI)
热水温度:	最大 70°C
推荐热水温度:	65°C

## 符号说明



请勿使用含有乙酸的硅胶！



大小 (参见第 11 页)



备用零件 (参见第 11 页)



清洗 (参见第 12 页)

安装 (参见第 10 页) 

## ТЕХНИЧЕСКИЕ ДАННЫЕ

Расход при 0,3 МПа:	12,5 л/мин
Рабочее давление:	не более. 1 МПа
Рекомендуемое рабочее давление:	0,1 - 0,5 МПа
Давления:	1,6 МПа (1 МПа = 10 bar = 147 PSI)
Температура горячей воды:	не более. 70°C
Рекомендуемая темп. гор. воды:	65°C

## MŰSZAKI ADATOK

Átfolyási teljesítmény 0,3 MPa:	12,5 l/perc
Üzemi nyomás:	max. 1 MPa
Ajánlott üzemi nyomás:	0,1 - 0,5 MPa
Nyomáspróba:	1,6 MPa (1 MPa = 10 bar = 147 PSI)
Forróvíz hőmérséklet:	max. 70°C
Forróvíz javasolt hőmérséklete:	65°C

## ОПИСАНИЕ СИМВОЛОВ



Не применяйте силикон, содержащий уксусную кислоту.



РАЗМЕРЫ (см. стр. 11)



КОМПЛЕКТ (см. стр. 11)



ОЧИСТКА (см. стр. 12)

МОНТАЖ (см. стр. 10)



## SZIMBÓLUMOK LEÍRÁSA



Ne használjon ecetsavtartalmú szilikont!



MÉRETET (lásd a oldalon 11)



TARTOZÉKOK (lásd a oldalon 11)



TISZTÍTÁS (lásd a oldalon 12)

SZERELÉS (lásd a oldalon 10)



## TEKNISET TIEDOT

Läpivirtausmäärä 0,3 MPa paineella:	12,5 l/min
Käyttöpaine:	maks. 1 MPa
Suosittelua käyttöpaine:	0,1 - 0,5 MPa
Koestuspaine:	1,6 MPa (1 MPa = 10 bar = 147 PSI)
Kuuman veden lämpötila:	maks. 70°C
Kuuman veden suosituslämpötila:	65°C

## TEKNISKA DATA

Flödeskapacitet vid 0,3 MPa:	12,5 l/min
Driftstryck:	max. 1 MPa
Rek. driftstryck:	0,1 - 0,5 MPa
Tryck vid provtryckning:	1,6 MPa (1 MPa = 10 bar = 147 PSI)
Varmvattentemperatur:	max. 70°C
Rek. varmvattentemp.:	65°C

## MERKIN KUVAUS



Älä käytä etikkahappoitoista silikonial!



MITAT (katso sivu 11)



VARAOSAT (katso sivu 11)



PUHDISTUS (katso sivu 12)

ASENNUS (katso sivu 10)



## SYMBOLFÖRKLARING



Använd inte silikon som innehåller ättiksyra!



MÅTTEN (se sidan 11)



RESERVDLAR (se sidan 11)



RENGÖRING (se sidan 12)

MONTERING (se sidan 10)



## TECHNINIAI DUOMENYS

Vandens pralaidumas, esant 0,3 MPa slėgiui: 12,5 l/min  
 Darbinis slėgis: ne daugiau kaip 1 MPa  
 Rekomenduojamas slėgis: 0,1 - 0,5 MPa  
 Bandomasis slėgis: 1,6 MPa  
 (1 MPa = 10 barų = 147 PSI)  
 Karšto vandens temperatūra: ne daugiau kaip 70°C  
 Rekomenduojama karšto vandens temperatūra: 65°C

## SIMBOLIO APRAŠYMAS



Nenaudokite silikono, kurio sudėtyje yra acto rūgšties!



IŠMATAVIMAI (žr. psl. 11)



ATSARGINĖS DALYS (žr. psl. 11)



VALYMAS (žr. psl. 12)

MONTAVIMAS (žr. psl. 10)



## TEKNİK BİLGİLER

0,3 MPa'daki debi: 12,5 l/dak  
 İşletme basıncı: azami 1 MPa  
 Tavsiye edilen işletme basıncı: 0,1 - 0,5 MPa  
 Kontrol basıncı: 1,6 MPa  
 (1 MPa = 10 bar = 147 PSI)  
 Sıcak su sıcaklığı: azami 70°C  
 Tavsiye edilen su ısıtı: 65°C

## SİMGE AÇIKLAMASI



Asetik asit içeren silikon kullanmayın!



ÖLÇÜLERİ (bakınız sayfa 11)



YEDEK PARÇALAR (bakınız sayfa 11)



TEMİZLEME (bakınız sayfa 12)

MONTAJI (bakınız sayfa 10)



## TEHNIČKI PODATCI

Protok vode uz tlak od 0,3 MPa: 12,5 l/min  
 Najveći dopušteni tlak: tlak 1 MPa  
 Preporučeni tlak: 0,1 - 0,5 MPa  
 Probni tlak: 1,6 MPa  
 (1 MPa = 10 bar = 147 PSI)  
 Temperatura vruće vode: tlak 70°C  
 Preporučena temperatura vruće vode: 65°C

## OPIS SIMBOLA



Nemojte koristiti silikon koji sadrži octenu kiselinu!



MJERE (pogledaj stranicu 11)



REZERVNI DJELOVI (pogledaj stranicu 11)



ČIŠĆENJE (pogledaj stranicu 12)

SASTAVLJANJE (pogledaj stranicu 10)



## DATE TEHNICE

Debit de apă la 0,3 MPa: 12,5 l/min  
 Presiune de funcționare: max. 1 MPa  
 Presiune de funcționare recomandată: 0,1 - 0,5 MPa  
 Presiune de verificare: 1,6 MPa  
 (1 MPa = 10 bar = 147 PSI)  
 Temperatura apei calde: max. 70°C  
 Temperatura recomandată a apei calde: 65°C

## DESCRIEREA SIMBOLURILOR



Nu utilizați silicon cu conținut de acid acetic!



DIMENSIUNI (vezi pag. 11)



PIESE DE SCHIMB (vezi pag. 11)



CURĂȚARE (vezi pag. 12)

MONTARE (vezi pag. 10)



## ΤΕΧΝΙΚΑ ΧΑΡΑΚΤΗΡΙΣΤΙΚΑ

Κατανάλωση νερού στα 0,3 MPa:	12,5 l/min
Λειτουργία πίεσης:	έως 1 MPa
Συνιστώμενη λειτουργία πίεσης:	0,1 - 0,5 MPa
Πίεση ελέγχου:	1,6 MPa
	(1 MPa = 10 bar = 147 PSI)
Θερμοκρασία ζεστού νερού:	έως 70°C
Συνιστώμενη θερμοκρασία ζεστού νερού:	65°C

## TEHNIČNI PODATKI

Pretok vode pri 0,3 MPa:	12,5 l/min
Delovni tlak:	maks. 1 MPa
Priporočeni delovni tlak:	0,1 - 0,5 MPa
Preskusni tlak:	1,6 MPa
	(1 MPa = 10 bar = 147 PSI)
Temperatura tople vode:	maks. 70°C
Priporočena temperatura tople vode:	65°C

## ΠΕΡΙΓΡΑΦΗ ΣΥΜΒΟΛΩΝ



Μην χρησιμοποιείτε σιλικόνη που περιέχει οξικό οξύ!

## OPIS SIMBOLA



Ne smete uporabiti silikona, ki vsebuje očetno kislino!



ΔΙΑΣΤΑΣΕΙΣ (βλ. Σελίδα 11)



MERE (glejte stran 11)



ΑΝΤΑΛΛΑΚΤΙΚΑ (βλ. Σελίδα 11)



REZERVNI DELI (glejte stran 11)



ΚΑΘΑΡΙΣΜΟΣ (βλ. Σελίδα 12)



ČIŠČENJE (glejte stran 12)

ΣΥΝΑΡΜΟΛΟΓΗΣΗ (βλ. Σελίδα 10)



ΜΟΝΤΑΖΑ (glejte stran 10)



## TEHNILISED ANDMED

Läbivool, kui rõhk on 0,3 MPa:	12,5 l/min
Töörõhk	maks. 1 MPa
Soovitatav töö rõhk:	0,1 - 0,5 MPa
Kontrollsurve:	1,6 MPa
	(1 MPa = 10 baari = 147 PSI)
Kuum vee temperatuur:	maks. 70°C
Soovitatav kuum vee temperatuur:	65°C

## TEHNISKIE DATI

Caurteces intensitāte pie 0,3 MPa:	12,5 l/min
Darba spiediens:	maks. 1 MPa
Ieteicamais darba spiediens:	0,1 - 0,5 MPa
Pārbaudes spiediens:	1,6 MPa
	(1 MPa = 10 bar = 147 PSI)
Karstā ūdens temperatūra:	maks. 70°C
Ieteicamā karstā ūdens temperatūra:	65°C

## SÛMBOLITE KIRJELDUS



Ärge kasutage äädikhapet sisaldavat silikoonil!

## SIMBOLU NOZĪME



Neizmantoj silikonu, kas satur etiķskābi!



MÕÕTUDE (vt lk 11)



IZMĒRUS (skat. lpp. 11)



VARUOSAD (vt lk 11)



REZERVES DAĻAS (skat. lpp. 11)



PUHASTAMINE (vt lk 12)



TĪRĪŠANA (skat. lpp. 12)

PAIGALDAMINE (vt lk 10)



MONTĀŽA (skat. lpp. 10)





## TEHNIČKI PODACI

Protok vode pri pritisku od 0,3 MPa:	12,5 l/min
Radni pritisak:	maks. 1 MPa
Preporučeni radni pritisak:	0,1 - 0,5 MPa
Probni pritisak:	1,6 MPa
	(1 MPa = 10 bar = 147 PSI)
Temperatura vruće vode:	maks. 70°C
Preporučena temperatura vruće vode:	65°C

## OPIS SIMBOLA



Nemojte koristiti silikon koji sadrži sircetnu kiselinu!



MERE (vidi stranu 11)



REZERVNI DELOVI (vidi stranu 11)



ČIŠĆENJE (vidi stranu 12)

МОНТАЖА (vidi stranu 10)

## BG

## ТЕХНИЧЕСКИ ДАННИ

Мощност на потока при 0,3 МПа:	12,5 л/мин
Работно налягане:	макс. 1 МПа
Препоръчително работно налягане:	0,1 - 0,5 МПа
Контролно налягане:	1,6 МПа
	(1 МПа = 10 bar = 147 PSI)
Температура на горещата вода:	макс. 70°C
Препоръчителна температура на горещата вода:	65°C

## ОПИСАНИЕ НА СИМВОЛИТЕ



Не използвайте силикон, съдържащ оцетна киселина!



РАЗМЕРИ (вижте стр. 11)



СЕРВИЗНИ ЧАСТИ (вижте стр. 11)



ПОЧИСТВАНЕ (вижте стр. 12)

МОНТАЖ (вижте стр. 10)

## TEKNISKE DATA

Gjennomstrømningsytelse ved 0,3 MPa:	12,5 l/min
Driftstrykk:	maks. 1 MPa
Anbefalt driftstrykk:	0,1 - 0,5 MPa
Prøvetrykk:	1,6 MPa
	(1 MPa = 10 bar = 147 PSI)
Varmtvannstemperatur:	maks. 70°C
Anbefalt temperatur for varmt vann:	65°C

## SYMBOLBESKRIVELSE



Ikke bruk silikon som inneholder eddiksyre!



MÅL (se side 11)



SERVICEDELER (se side 11)



RENGJØRING (se side 12)

МОНТАСЈЕ (se side 10)

## SQ

## TË DHËNA TEKNIKE

Kapaciteti i rrjedhjes në 0,3 MPa:	12,5 l/min
Presioni gjatë punës:	maks. 1 MPa
Presioni i rekomanduar:	0,1 - 0,5 MPa
Presioni për provë:	1,6 MPa
	(1 MPa = 10 bar = 147 PSI)
Temperatura e ujit të ngrohtë:	maks. 70°C
Temperatura e rekomanduar e ujit të ngrohtë:	65°C

## PËRSHKRIMI I SIMBOLIT



Mos përdorni silikon që në përbërje ka acid acetik.



PËRMASAT (shih faqen 11)



PJESËT E SERVISIT (shih faqen 11)



PASTRIMI (shih faqen 12)

МОНТИМИ (shih faqen 10)

### المواصفات الفنية

معدل التدفق عند ضغط 0,3 ميجاباسكال: 12,5 لتر / الدقيقة

ضغط التشغيل: الحد الأقصى 1 ميجاباسكال

ضغط التشغيل الموصى به: 0,1 - 0,5 ميجاباسكال

ضغط الاختبار: 1,6 ميجاباسكال

(1 ميجاباسكال = 10 بار = 147 PSI)

درجة حرارة الماء الساخن: الحد الأقصى 70°C

درجة الحرارة الموصى بها للماء الساخن: 65°C

### وصف الرمز

هام! لا تستخدم السليكون الذي يحتوي على أحماض! 

أبعاد (راجع صفحة 11) 

قطع الغيار (راجع صفحة 11) 

التنظيف (راجع صفحة 12) 

التركيب (راجع صفحة 10) 

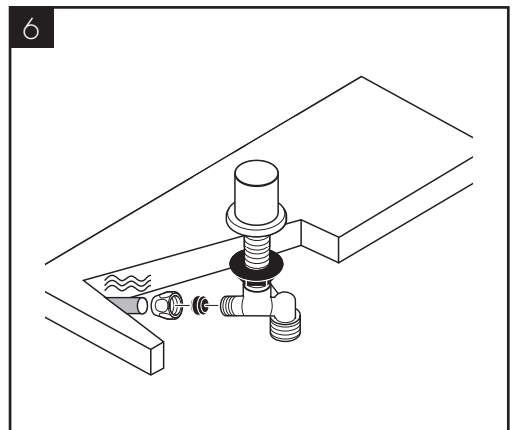
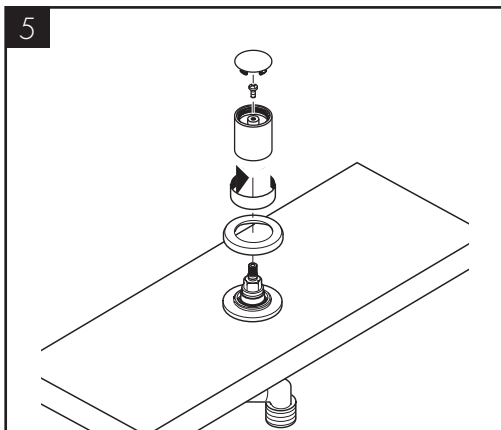
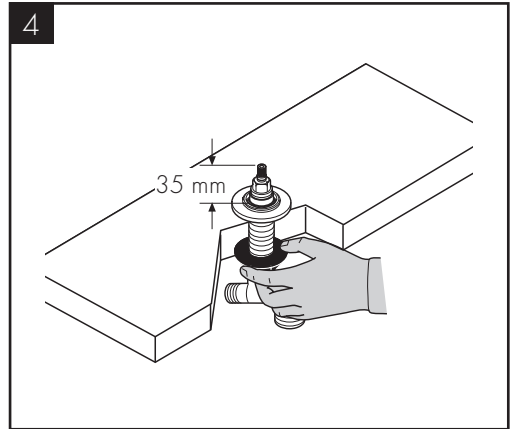
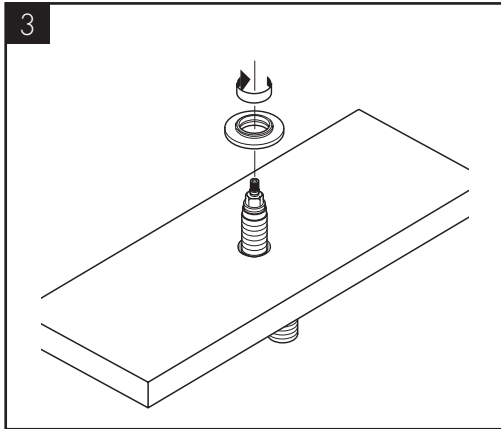
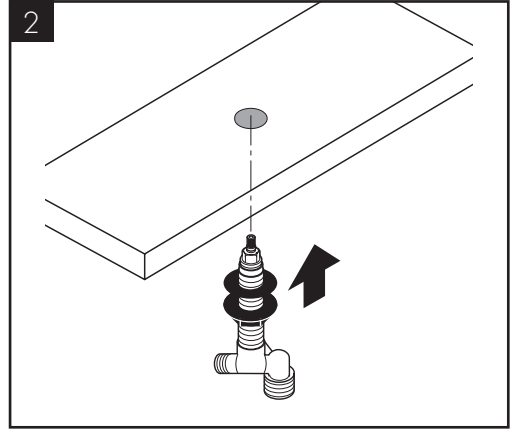
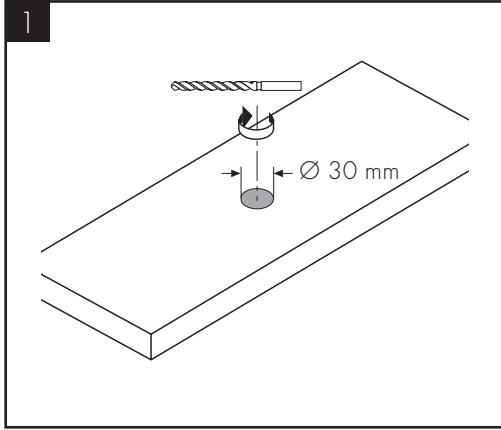

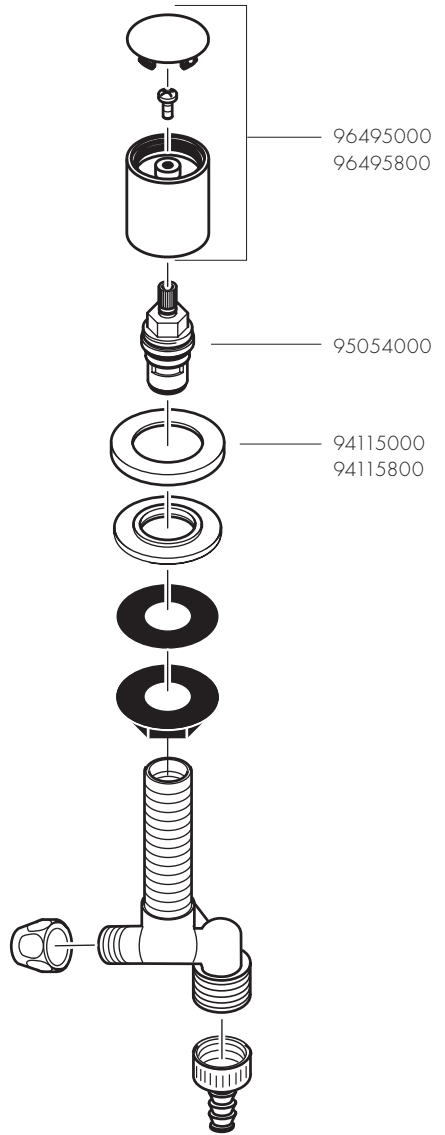
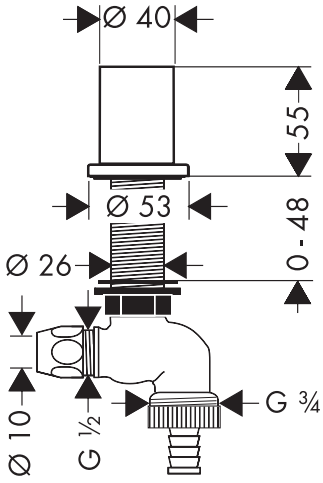

# AXOR

DE / Reinigungsempfehlung / Garantie / Kontakt  
FR / Recommendation pour le nettoyage / Garanties / Contact  
EN / Cleaning recommendation / Warranty / Contact  
IT / Raccomandazione di pulizia / Garanzia / Contatto  
ES / Recomendaciones para la limpieza / Garantía / Contacto  
NL / Aanbevelingen inzake reiniging / Garantie / Contact  
DK / Rensning, anbefaling / Garanti / Kontakt  
PT / Recomendações de limpeza / Garantia / Contacto  
PL / Zalecenie dotyczące pielęgnacji / Gwarancja / Kontakt  
CS / Doporučení k čištění / Záruka / Kontakt  
SK / Odporúčania pre čistenie / Záruka / Kontakt  
ZH / 清洁指南 / 担保 / 接触  
RU / Рекомендации по очистке / Гарантия / Контакты  
HU / Tisztítási tanácsok / Garancia / érintkezés  
FI / Puhdistussuositus / Takuu / Kosketus  
SV / Rengöringsrekommendationer / Garanti / Contacto  
LT / Valymo rekomendacijos / Garantija / Kontaktai  
HR / Preporuke za čišćenje / Garancija / Kontakt  
TR / Temizleme önerisi / Garanti / Temas  
RO / Recomandări pentru curățare / Garanție / Contact  
EL / Σύσταση καθαρισμού / Εγγύηση / επαφή  
SL / Priporočilo za čiščenje / Garancija / Kontakt  
ET / Puhastussuovitused / Garantii / Kontakt  
LV / Tīrīšanas ieteikumi / Garantija / Kontakti  
SR / Preporuke za čišćenje / Garancija / Kontakt  
NO / Anbefaling for rengjøring / Garanti / Kontakt  
BG / Препоръка за почистване / Гаранция / Контакт  
SQ / Këshilla rreth pastrimit / Garancia / Kontakt  
KO / 세정시 권장사항 / 품질보증 / 접촉  
AR / توصيات التنظيف / الضمان (الولايات المتحدة الأمريكية) / اتصال

AXOR / Hansgrohe SE

Austraße 5-9

77761 Schiltach

Deutschland

info@axor-design.com

axor-design.com



[www.axor-design.com/  
cleaning-recommendation](http://www.axor-design.com/cleaning-recommendation)

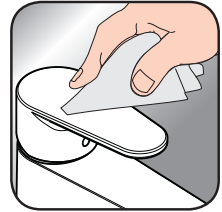

[www.axor-design.com/  
cleaning-recommendation](http://www.axor-design.com/cleaning-recommendation)



[www.axor-design.com/  
cleaning-recommendation](http://www.axor-design.com/cleaning-recommendation)



[www.axor-design.com/  
cleaning-recommendation](http://www.axor-design.com/cleaning-recommendation)