



UNIDOMO®

Web: www.unidomo.de

Telefon: 04621- 30 60 89 0

Mail: info@unidomo.com

Öffnungszeiten: Mo.-Fr. 8:00-17:00 Uhr

VIESMANN

Buderus

 **Vaillant**

WOLF

 **JUNKERS**  **BOSCH**

 **remeha**

 **DAIKIN**

ROTEX

a member of DAIKIN group



-  Individuelle Beratung
-  Kostenloser Versand
-  Hochwertige Produkte

-  Komplettpakete
-  Über 15 Jahre Erfahrung
-  Markenhersteller

AXOR

DE / Gebrauchsanleitung / Montageanleitung	02
FR / Mode d'emploi / Instructions de montage	03
EN / Instructions for use / assembly instructions	04
IT / Istruzioni per l'uso / Istruzioni per l'installazione	05
ES / Modo de empleo / Instrucciones de montaje	06
NL / Gebruiksaanwijzing / Handleiding	07
DK / Brugsanvisning / Monteringsvejledning	08
PT / Instruções para uso / Manual de instalação	09
PL / Instrukcja obsługi / Instrukcja montażu	10
CS / Návod k použití / Montážní návod	11
SK / Návod na použitie / Montážny návod	12
ZH / 用户手册 / 组装说明	13
RU / Руководство пользователя / Инструкция по монтажу	14
FI / Käyttöohje / Asennusohje	15
SV / Bruksanvisning / Monteringsanvisning	16
LT / Vartotojo instrukcija / Montavimo instrukcijos	17
HR / Upute za uporabu / Uputstva za instalaciju	18
TR / Kullanım kılavuzu / Montaj kılavuzu	19
RO / Manual de utilizare / Instrucțiuni de montare	20
EL / Οδηγίες χρήσης / Οδηγία συναρμολόγησης	21
SL / Navodilo za uporabo / Navodila za montažo	22
ET / Kasutusjuhend / Paigaldusjuhend	23
LV / Lietošanas pamācība / Montāžas instrukcija	24
SR / Uputstvo za upotrebu / Uputstvo za montažu	25
NO / Bruksanvisning / Montasjeveiledning	26
BG / Инструкции за употреба / Ръководство за монтаж	27
SQ / Udhëzuesi i përdorimit / Udhëzime rreth montimit	28
AR / تعليمات التجميع / دليل الاستخدام	29
HU / Használati útmutató / Szerelési útmutató	30

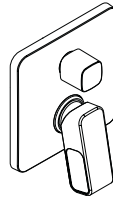

AXOR Urquiola
11425000

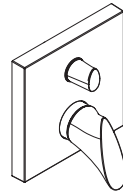

AXOR Starck Organic
12415000

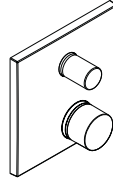

AXOR Massaud
18455000

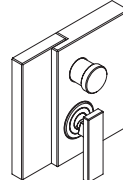

AXOR Edge
46450000 / 46451000

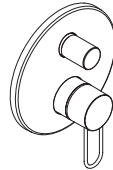

AXOR Uno
38426XXX

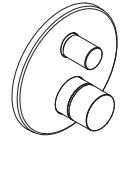

AXOR Uno
45405XXX

⚠ SICHERHEITSHINWEISE

- ⚠ Bei der Montage müssen zur Vermeidung von Quetsch- und Schnittverletzungen Handschuhe getragen werden.
- ⚠ Das Produkt darf nur zu Bade-, Hygiene- und Körperreinigungszwecken eingesetzt werden.
- ⚠ Große Druckunterschiede zwischen den Kalt- und Warmwasseranschlüssen müssen ausgeglichen werden.

MONTAGEHINWEISE

- / Vor der Montage muss das Produkt auf Transportschäden untersucht werden. Nach dem Einbau werden keine Transport- oder Oberflächenschäden anerkannt.
- / Die Leitungen und die Armatur müssen nach den gültigen Normen montiert, gespült und geprüft werden.
- / Die in den Ländern jeweils gültigen Installationsrichtlinien sind einzuhalten.

TECHNISCHE DATEN

Betriebsdruck:	max. 1 MPa
Empfohlener Betriebsdruck:	0,1 - 0,5 MPa
Prüfdruck:	1,6 MPa (1 MPa = 10 bar = 147 PSI)
Heißwassertemperatur:	max. 70°C
Empfohlene Heißwassertemperatur:	65°C
Thermische Desinfektion:	max. 70°C/4 min

Das Produkt ist ausschließlich für Trinkwasser konzipiert!

SYMBOLERKLÄRUNG



Kein essigsäurehaltiges Silikon verwenden!



JUSTIERUNG (siehe Seite 38)

Einstellen der Warmwasserbegrenzung. In Verbindung mit Durchlauferhitzern ist eine Warmwassersperre nicht zu empfehlen.



MASSE (siehe Seite 39)



DURCHFLUSSDIAGRAMM
(siehe Seite 39)
freier Durchfluss



SERVICETEILE (siehe Seite 42)

XXX = Farbcodierung
000 = Chrom
310 = Brushed Redgold
330 = Polished Black Chrome
820 = Brushed Nickel
930 = Polished Brass



SONDERZUBEHÖR (siehe Seite 44)

nicht im Lieferumfang enthalten
/ Verlängerung 25 mm #13595000

/ Verlängerung 33 mm (bei geringer Einbautiefe) #14972XXX, #14968XXX, #14961XXX



REINIGUNG (siehe Seite 45)



BEDIENUNG (siehe Seite 40)



PRÜFZEICHEN (siehe Seite 46)

STÖRUNG

URSACHE

ABHILFE

/ Armatur schwergängig	/ Kartusche defekt, verkalkt	/ Kartusche austauschen
/ Armatur tropft	/ Kartusche defekt	/ Kartusche austauschen
/ Umsteller funktioniert nicht	/ Ablagerungen	/ Umsteller reinigen/ O-Ringe fetten
	/ Zu geringer Wasserdruck	/ Wasserdruck erhöhen
	/ Umsteller defekt	/ Umsteller austauschen
/ Zu niedrige Warmwassertemperatur, kein Kaltwasser. Durchlauferhitzer springt an, wenn Kaltwasser angewählt wird.	/ Warmwasserbegrenzung falsch eingestellt	/ Warmwasserbegrenzung einstellen
	/ Kreuzfluss	/ Kartusche austauschen



△ CONSIGNES DE SÉCURITÉ

- △ Lors du montage, porter des gants de protection pour éviter toute blessure par écrasement ou coupure.
- △ Le produit ne doit servir qu'à se laver et à assurer l'hygiène corporelle.
- △ Il est conseillé d'équilibrer les pressions de l'eau chaude et froide.

INSTRUCTIONS POUR LE MONTAGE

- / Avant son montage, s'assurer que le produit n'a subi aucun dommage pendant le transport. Après le montage, tout dommage de transport ou de surface ne pourra pas être reconnu.
- / Les conduites et la robinetterie doivent être montés, rincés et contrôlés selon les normes en vigueur.
- / Les directives d'installation en vigueur dans le pays concerné doivent être respectées.

INFORMATIONS TECHNIQUES

Pression de service autorisée:	max. 1 MPa
Pression de service conseillée:	0,1 - 0,5 MPa
Pression maximum de contrôle:	1,6 MPa (1 MPa = 10 bar = 147 PSI)
Température d'eau chaude:	max. 70°C
Température recommandée:	65°C
Désinfection thermique:	max. 70°C / 4 min
Le produit est exclusivement conçu pour de l'eau potable!	

DESCRIPTION DU SYMBOLE



Ne pas utiliser de silicone contenant de l'acide acétique!



ETALONNAGE (voir pages 38)

Réglage de la limitation d'eau chaude. En liaison avec les chauffe-eau, un blocage de l'eau chaude n'est pas recommandable.



DIMENSIONS (voir pages 39)



DIAGRAMME DU DÉBIT

(voir pages 39)

débit libre



PIÈCES DÉTACHÉES (voir pages 42)

XXX = Couleurs

000 = Chromé

310 = Brushed Redgold

330 = Polished Black Chrome

820 = Brushed Nickel

930 = Polished Brass



ACCESSOIRES EN OPTION

(voir pages 44)

ne fait pas partie de la fourniture

/ jeu de rallonge 25 mm #13595000

/ Rallonge de 33 mm (pour profondeur de montage trop faible) #14972XXX, #14968XXX, #14961XXX



NETTOYAGE (voir pages 45)



INSTRUCTIONS DE SERVICE

(voir pages 40)



CLASSIFICATION ACOUSTIQUE ET DÉBIT (voir pages 46)

DYSFONCTIONNEMENT	ORIGINE	SOLUTION
/ Dureté de fonctionnement	/ Cartouche défectueuse, entartrée	/ Changer la cartouche
/ Le mitigeur goutte	/ Cartouche défectueuse	/ Changer la cartouche
/ L'inverseur ne fonctionne pas	/ Dépôts	/ Nettoyer l'inverseur / graisser les joints toriques
	/ Pression d'alimentation insuffisante	/ Augmenter la pression d'alimentation
	/ Inverseur défectueux	/ Changez l'inverseur
/ Température d'eau chaude trop basse, pas d'eau froide. Le chauffe eau instantané met en route quand on puise de l'eau froide.	/ Limiteur de température mal positionné	/ Positionner le limiteur de température
	/ Flux inversé	/ Changer la cartouche

△ SAFETY NOTES

- △ Gloves should be worn during installation to prevent crushing and cutting injuries.
- △ The product may only be used for bathing, hygienic and body cleaning purposes.
- △ The hot and cold supplies must be of equal pressures.

INSTALLATION INSTRUCTIONS

- / Prior to installation, inspect the product for transport damages. After it has been installed, no transport or surface damage will be honoured.
- / The pipes and the fixture must be installed, flushed and tested as per the applicable standards.
- / The plumbing codes applicable in the respective countries must be observed.

TECHNICAL DATA

Operating pressure:	max. 1 MPa
Recommended operating pressure:	0,1 - 0,5 MPa
Test pressure:	1,6 MPa
	(1 MPa = 10 bar = 147 PSI)
Hot water temperature:	max. 70°C
Recommended hot water temp.:	65°C
Thermal disinfection:	max. 70°C / 4 min
The product is exclusively designed for drinking water!	

SYMBOL DESCRIPTION

Do not use silicone containing acetic acid!



ADJUSTMENT (see page 38)

To adjust the hot water limiter. Using a hot water limiter in combination with a continuous flow water heater is not recommended.



DIMENSIONS (see page 39)



FLOW DIAGRAM (see page 39)
free flow



SPARE PARTS (see page 42)

XXX = Colors
000 = Chrome Plated
310 = Brushed Redgold
330 = Polished Black Chrome
820 = Brushed Nickel
930 = Polished Brass



SPECIAL ACCESSORIES
(see page 44)

order as an extra

/ extension 25 mm #13595000

/ Extension Set 33 mm (when wall is not deep enough) #14972XXX, #14968XXX, #14961XXX



CLEANING (see page 45)



OPERATION (see page 40)



TEST CERTIFICATE (see page 46)

FAULT	CAUSE	REMEDY
/ Mixer stiff	/ Cartridge defective, calcified	/ Exchange cartridge
/ Mixer dripping	/ Cartridge defective	/ Exchange cartridge
/ Diverter not operating	/ Residue	/ Clean converter / grease O-rings
	/ Water pressure too low	/ Increase water pressure
	/ Diverter defective	/ Exchange diverter
/ Hot water temperature too low, no cold water. Instantaneous water heater starts up when cold water is selected.	/ Hot water limiter incorrectly set	/ Set hot water limiter
	/ Crossflow	/ Exchange cartridge



△ INDICAZIONI SULLA SICUREZZA

- △ Durante il montaggio, per evitare ferite da schiacciamento e da taglio bisogna indossare guanti protettivi.
- △ Il prodotto deve essere utilizzato esclusivamente per fare il bagno e per l'igiene del corpo.
- △ Attenzione! Compensare le differenze di pressione tra i collegamenti dell'acqua fredda e dell'acqua calda.

ISTRUZIONI PER IL MONTAGGIO

- / Prima del montaggio è necessario controllare che non ci siano stati danni durante il trasporto. Una volta eseguito il montaggio, non verranno riconosciuti eventuali danni di trasporto o delle superfici.
- / Montare, lavare e controllare tubature e rubinetteria rispettando le norme correnti.
- / Vanno rispettate le direttive di installazione nazionali vigenti nel rispettivo paese.

DATI TECNICI

Pressione d'uso:	max. 1 MPa
Pressione d'uso consigliata:	0,1 - 0,5 MPa
Pressione di prova:	1,6 MPa
	(1 MPa = 10 bar = 147 PSI)
Temperatura dell'acqua calda:	max. 70°C
Temp. dell'acqua calda consigliata:	65°C
Disinfezione termica:	max. 70°C / 4 min

Il prodotto è concepito esclusivamente per acqua potabile!

DESCRIZIONE SIMBOLO



Non utilizzare silicone contenente acido acetico!



TARATURA (vedi pagg. 38)

Regolazione del limitatore di erogazione d'acqua calda. Un limitatore di erogazione di

acqua calda in combinazione con le caldaie istantanee non è consigliabile.



INGOMBRI (vedi pagg. 39)

DIAGRAMMA FLUSSO
(vedi pagg. 39)

portata libero



PARTI DI RICAMBIO

(vedi pagg. 42)

XXX = Trattamento

000 = Cromato

310 = Brushed Redgold

330 = Polished Black Chrome

820 = Brushed Nickel

930 = Polished Brass



ACCESSORI SPECIALI

(vedi pagg. 44)

non contenuto nel volume di fornitura

/ Prolunga 25 mm #13595000

/ Prolunga 33 mm x set esterno (in caso di incasso troppo esterno al muro) #14972XXX, #14968XXX, #14961XXX



PULITURA (vedi pagg. 45)



PROCEDURA (vedi pagg. 40)



SEGNO DI VERIFICA

(vedi pagg. 46)

PROBLEMA	POSSIBILE CAUSA	RIMEDIO
/ Miscelatore duro	/ Cartuccia difettosa	/ Sostituire la cartuccia
/ Miscelatore gocciola	/ Cartuccia difettosa	/ Sostituire la cartuccia
/ Deviatore non funziona	/ depositi calcarei	/ pulire il regolatore/ingrassare le guarnizioni O-ring
	/ pressione d'acqua troppo bassa	/ alzare la pressione d'acqua
	/ deviatore difettoso	/ sostituire deviatore
/ Temperatura dell'acqua calda troppo bassa, niente acqua fredda, caldaia istantanea si accende quando si seleziona acqua fredda	/ Limitazione dell'acqua calda regolata male	/ Regolare la limitazione dell'acqua calda
	/ Flusso incrociato	/ Sostituire la cartuccia



INDICACIONES DE SEGURIDAD

- ⚠ Durante el montaje deben utilizarse guantes para evitar heridas por aplastamiento o corte.
- ⚠ El producto solo debe ser utilizado para fines de baño, higiene y limpieza corporal.
- ⚠ Grandes diferencias de presión en servicio entre agua fría y agua caliente deben equilibrarse.

INDICACIONES PARA EL MONTAJE

- / Antes del montaje se debe examinarse el producto contra daños de transporte. Después de la instalación no se reconoce ningún daño de transporte o de superficie.
- / Los conductos y la grifería deben montarse, lavarse y comprobarse según las normas vigentes.
- / Es obligatorio el cumplimiento de las directrices de instalación vigentes en el país respectivo.

DATOS TÉCNICOS

Presión en servicio: max. 1 MPa
 Presión recomendada en servicio: 0,1 - 0,5 MPa
 Presión de prueba: 1,6 MPa
 (1 MPa = 10 bar = 147 PSI)
 Temperatura del agua caliente: max. 70°C
 Temp. recomendada del agua caliente: 65°C
 Desinfección térmica: max. 70°C / 4 min
 El producto ha sido concebido exclusivamente para agua potable.

DESCRIPCIÓN DE SÍMBOLOS

 No utilizar silicona que contiene ácido acético!



AJUSTE (ver página 38)

Ajuste del límite de agua caliente. En combinación con calentadores continuos no es recomendable utilizar un bloqueo de agua caliente.



DIMENSIONES (ver página 39)



DIAGRAMA DE CIRCULACIÓN (ver página 39)
caudal libre



REPUESTOS (ver página 42)

- XXX = Acabados
- 000 = Cromado
- 310 = Brushed Redgold
- 330 = Polished Black Chrome
- 820 = Brushed Nickel
- 930 = Polished Brass



OPCIONAL (ver página 44)

- no incluido en el suministro
- / Prolongación 25 mm #13595000
- / Alargo 33 mm (en caso de pared delgada) #14972XXX, #14968XXX, #14961XXX



LIMPIAR (ver página 45)



MANEJO (ver página 40)



MARCA DE VERIFICACIÓN (ver página 46)

PROBLEMA	CAUSA	SOLUCIÓN
/ Manecilla va dura	/ cartucho dañado	/ cambiar el cartucho
/ Grifo pierde agua	/ cartucho dañado	/ cambiar el cartucho
/ Inversor no funciona	/ Depósitos	/ Limpiar conmutador de tomas/engrasar anillos tóricos
	/ falta presión	/ aumentar presión
	/ inversor defecto	/ cambiar inversor
/ Temperatura del agua caliente demasiado baja, agua fría calentador se dispara al abrir agua fría	/ tope de agua caliente mal	/ ajustar tope
	/ Flujo cruzado	/ cambiar el cartucho

△ VEILIGHEIDSINSTRUCTIES

- △ Bij de montage moeten ter voorkoming van knel- en snijwonden handschoenen worden gedragen.
- △ Het product mag alleen voor het wassen, hygiënische doeleinden en voor de lichaamreiniging worden gebruikt.
- △ Grote drukverschillen tussen de koud- en warmwater-toevoer dienen vermeden te worden.

MONTAGE-INSTRUCTIES

- / Vóór de montage moet het product gecontroleerd worden op transportschade. Na de inbouw wordt geen transport- of oppervlakteschade meer aanvaard.
- / De leidingen en armaturen moeten gemonteerd, gespoeld en gecontroleerd worden volgens de geldige normen.
- / De in de overeenkomstige landen geldende installatie-richtlijnen moeten nageleefd worden.

TECHNISCHE GEGEVENS

Werkdruk: max.	max. 1 MPa
Aanbevolen werkdruk:	0,1 - 0,5 MPa
Getest bij:	1,6 MPa
	(1 MPa = 10 bar = 147 PSI)
Temperatuur warm water:	max. 70°C
Aanbevolen warm water temp.:	65°C
Thermische desinfectie:	max. 70°C/4 min
Het product is uitsluitend ontworpen voor drinkwater!	

SYMBOOLBESCHRIJVING



Gebruik geen zuurhoudende siliconen!



INSTELLEN (zie blz. 38)

Instellen van de warmwaterbegrenzing. In combinatie met een doorstromer is een warmwaterblokkering niet aanbevelenswaardig.



MATEN (zie blz. 39)



DOORSTROOMDIAGRAM (zie blz. 39)

vrije doorstroom



SERVICE ONDERDELEN (zie blz. 42)

XXX = Kleuren

000 = Verchroomd

310 = Brushed Redgold

330 = Polished Black Chrome

820 = Brushed Nickel

930 = Polished Brass



TOEBEHOREN (zie blz. 44)

behoort niet tot het leveringspakket

/ Verlengstuk 25 mm #13595000

/ verlengset 33 mm (bij geringe inbouwdiepte)
#14972XXX, #14968XXX, #14961XXX



REINIGEN (zie blz. 45)



BEDIENING (zie blz. 40)



KEURMERK (zie blz. 46)

STORING

- / Bediening zwaar
- / Mengkraan lekt
- / Omstelling functioneert niet
- / Warmwater temperatuur te laag, geen koud water. Doorstroomtoestel springt aan wanneer koud water gekozen is.

OORZAAK

- / Kardoes defect of verkalkt
- / Kardoes defect
- / Afzettingen
- / Waterdruk te laag
- / Omstelling defect
- / Heetwaterbegrenzer verkeerd ingesteld
- / Kruisstroom

OPLOSSING

- / Kardoes uitwisselen
- / Kardoes uitwisselen
- / Omsteller reinigen/O-ringen invetten
- / Waterdruk verhogen
- / Omstelling uitwiss
- / Heetwaterbegrenzer instellen
- / Kardoes uitwisselen



△ SIKKERHEDSANVISNINGER

- △ Ved monteringen skal der bruges handsker for at undgå kvæstelser og snitsår.
- △ Produktet må kun bruges til bade-, hygiejne og kropsurengøringsformål.
- △ Større trykforskelle mellem koldt og varmt vand bør udjævnes.

MONTERINGSANVISNINGER

- / Før monteringen skal produktet kontrolleres for transportskader. Efter monteringen godkendes transportskader eller skader på overfladen ikke længere.
- / Ledningerne og armaturerne skal monteres, skylles og kontrolleres iht. de gældende standarder.
- / Installationsbestemmelserne, der gælder i det enkelte land, skal overholdes.

TEKNISKE DATA

Driftstryk:	max. 1 MPa
Anbefalet driftstryk:	0,1 - 0,5 MPa
Prøvetryk:	1,6 MPa
	(1 MPa = 10 bar = 147 PSI)
Varmtvandstemperatur:	max. 70°C
Anbefalet varmtvandstemperatur:	65°C
Termisk desinfektion:	max. 70°C/4 min
Produktet er udelukkende beregnet til drikkevand!	

SYMBOLBESKRIVELSE



Der må ikke benyttes eddikesyreholdig silikone!

FORINDSTILLING (se s. 38)

Indstilling af varmvandsbegrænsningen. I forbindelse med gennemstrømningsvandvarmere anbefaler vi ikke en varmvandsspærre.

FEJL	ÅRSAG	HJÆLP
/ Grebet går trægt	/ Kartusche defekt, tilkalket	/ Udskift kartusche
/ Armaturet drypper	/ Defekt kartusche	/ Udskift kartusche
/ Omstiller virker ikke	/ Aflejringer	/ Rens omskifteren / smør O-ringe
	/ For lavt vandtryk	/ Forøg vandtrykket
	/ Defekt omstiller	/ Udskift omstilleren
/ For lav varmtvandstemperatur. Ingen koldt vand. Vandvarmeren starter, når der åbnes for det kolde vand.	/ Varmtvandsbegrænsningen er forkert indstillet	/ Indstil varmtvandsbegrænsningen
	/ Kryds-flow	/ Udskift kartusche



MÅLENE (se s. 39)

GENNEMSTRØMNINGSDIAGRAM (se s. 39)

fri gennemstrømning



RESERVEDELE (se s. 42)

- XXX = Overflade
- 000 = Krom
- 310 = Brushed Redgold
- 330 = Polished Black Chrome
- 820 = Brushed Nickel
- 930 = Polished Brass



SPECIALTILBEHØR (se s. 44)

ikke med i leveringsomfang

/ Forlængersæt 25 mm #13595000

/ Forlænger 33 mm (ved for stor indbygningsdybde) #14972XXX, #14968XXX, #14961XXX



RENGØRING (se s. 45)



BRUGSANVISNING (se s. 40)



GODKENDELSE (se s. 46)



△ AVISOS DE SEGURANÇA

- △ Durante a montagem devem ser utilizadas luvas de protecção, de modo a evitar ferimentos resultantes de entalamentos e de cortes.
- △ O produto só pode ser utilizado para fins de higiene pessoal.
- △ Grandes diferenças entre as pressões das águas quente e fria devem ser compensadas.

AVISOS DE MONTAGEM

- / Antes da montagem deve-se controlar o produto relativamente a danos de transporte. Após a montagem não são aceites quaisquer danos de transporte ou de superfície.
- / As tubagens e a torneira têm que ser montadas, enxaguadas e verificadas de acordo com as normas em vigor.
- / A prescrições de instalação válidas nos respetivos países devem ser respeitadas.

DADOS TÉCNICOS

Pressão de funcionamento:	max. 1 MPa
Pressão de func. recomendada:	0,1 - 0,5 MPa
Pressão testada:	1,6 MPa
	(1 MPa = 10 bar = 147 PSI)
Temperatura da água quente:	max. 70°C
Temp. água quente recomendada:	65°C
Desinfecção térmica:	max. 70°C / 4 min
Este produto foi única e exclusivamente concebido para água potável!	

DESCRIÇÃO DO SÍMBOLO



Não utilizar silicone que contenha ácido acético!



AFINAÇÃO (ver página 38)

Ajuste do limitador de água quente. Em combinação com um esquentador, não é recomendável o uso de um bloqueio de água quente.



MEDIDAS (ver página 39)

FLUXOGRAMA (ver página 39)
caudal livre



PEÇAS DE SUBSTITUIÇÃO (ver página 42)

XXX = Acabamentos
000 = Cromado
310 = Brushed Redgold
330 = Polished Black Chrome
820 = Brushed Nickel
930 = Polished Brass



ACESSÓRIOS ESPECIAIS (ver página 44)

não incluído no volume de fornecimento

/ Crescente 25 mm #13595000

/ Crescente 33 mm (quando instalado demasiado longe da parede) #14972XXX, #14968XXX, #14961XXX



LIMPEZA (ver página 45)



FUNCIÓNAMENTO (ver página 40)



MARCA DE CONTROLO (ver página 46)

FALHA	CAUSA	SOLUÇÃO
/ Misturadora perra	/ Cartucho defeituoso, calcificado	/ Substituir o cartucho
/ Misturadora a pingar	/ Cartucho defeituoso	/ Substituir o cartucho
/ Inversor não funciona	/ Depósitos	/ Limpar inversor/lubrificar vedantes em O
	/ Pressão da água muito baixa	/ Aumentar a pressão da água
	/ Inversor defeituoso	/ Substituir o inversor
/ Temperatura da água quente muito baixa, sem água fria. O esquentador dispara quando a água fria está seleccionada.	/ O limitador de temperatura está incorrectamente colocado	/ Regular o limitador de temperatura
	/ Fluxo cruzado	/ Substituir o cartucho



△ WSKAZÓWKI BEZPIECZEŃSTWA

- △ Aby uniknąć zranień na skutek zgniecenia lub przecięcia, podczas montażu należy nosić rękawice ochronne.
- △ Produkt może być używany tylko do kąpieli, higieny i czyszczenia ciała.
- △ Znaczne różnice ciśnień na dopływach ciepłej i zimnej wody muszą zostać wyrównane.

WSKAZÓWKI MONTAŻOWE

- / Przed montażem należy skontrolować produkt pod kątem szkód transportowych. Po montażu nie widać żadnych szkód transportowych ani szkód na powierzchni.
- / Przewody i armatura muszą być montowane, płukane i kontrolowane według obowiązujących norm.
- / Należy przestrzegać wytycznych instalacyjnych obowiązujących w danym kraju.

DANE TECHNICZNE

Ciśnienie robocze:	maks. 1 MPa
Zalecane ciśnienie robocze:	0,1 - 0,5 MPa
Ciśnienie próbne:	1,6 MPa
	(1 MPa = 10 bary = 147 PSI)
Temperatura wody gorącej:	maks. 70°C
Zalecana temperatura wody gorącej:	65°C
Dezynfekcja termiczna:	maks. 70°C/4 min
Produkt przeznaczony wyłącznie do wody pitnej!	

OPIS SYMBOLU



Nie stosować silikonów zawierających kwas octowy!



USTAWIANIE (patrz strona 38)

Ustawianie ogranicznika ciepłej wody. Używanie ogranicznika temperatury wody w połączeniu z przepływowym podgrzewaczem wody nie jest zalecane.



WYMIARY (patrz strona 39)

SCHEMAT PRZEPŁYWU (patrz strona 39)

swobodny przepływ



CZĘŚCI SERWISOWE (patrz strona 42)

XXX = Kody kolorów

000 = Chrom

310 = Brushed Redgold

330 = Polished Black Chrome

820 = Brushed Nickel

930 = Polished Brass



WYPOSAŻENIE SPECJALNE (patrz strona 44)

Nie jest częścią dostawy

/ Przedłużka 25 mm #13595000

/ Rozeta maskująca 33 mm (przy małej głębokości zabudowy) #14972XXX, #14968XXX, #14961XXX



CZYSZCZENIE (patrz strona 45)



OBŚŁUGA (patrz strona 40)



ZNAK JAKOŚCI (patrz strona 46)

USTERKA	PRZYCZYNA	POMOC
/ Uchwyt armatury pracuje z wysiłkiem	/ Uszkodzony wkład, zakamieniony	/ Wymiana wkładu
/ Armatura cieknie	/ Uszkodzony wkład	/ Wymiana wkładu
/ Przelącznik nie funkcjonuje	/ Osady	/ Wyczyścić przelącznik/nasmarować o-ringi
	/ Zbyt niskie ciśnienie wody	/ Podnieść ciśnienie wody
	/ Uszkodzony przelącznik	/ Wymienić przelącznik
/ Za niska temperatura ciepłej wody, brak zimnej wody. Przepływowy podgrzewacz wody uruchamia się, gdy wybiera się zimną wodę.	/ Niewłaściwe ustawienie ogranicznik ciepłej wody	/ Ustawić ogranicznik ciepłej wody
	/ Przepływ krzyżowy	/ Wymiana wkładu

△ BEZPEČNOSTNÍ POKYNY

- △ Pro zabránění řezným zraněním a pohmožděninám je nutné při montáži nosit rukavice.
- △ Produkt smí být používán pouze ke koupání a za účelem tělesné hygieny.
- △ Je nutné vyrovnat velké rozdíly tlaku mezi přípoji studené a teplé vody.

POKYNY K MONTÁŽI

- / Před montáží je třeba produkt zkontrolovat, zda nebyl při transportu poškozen. Po zabudování nebudou uznány žádné škody způsobené transportem nebo poškození povrchu.
- / Vedení a armatura musí být namontovány, propláchnuty a otestovány podle platných norem.
- / Je třeba dodržovat montážní pravidla platné v dané zemi.

TECHNICKÉ ÚDAJE

Provozní tlak:	max. 1 MPa
Doporučený provozní tlak:	0,1 - 0,5 MPa
Zkušební tlak:	1,6 MPa
	(1 MPa = 10 bar = 147 PSI)
Teplota horké vody:	max. 70°C
Doporučená teplota horké vody:	65°C
Teplná desinfekce:	max. 70°C / 4 min

Výrobky Hansgrohe jsou vhodné pro přímý kontakt s pitnou vodou.

POPIS SYMBOLŮ



Nepoužívat silikon s obsahem kyseliny octové!



NASTAVENÍ (viz strana 38)

Nastavení omezovače teplé vody. Ve spojení s průtokovým ohřívačem se použití uzávěru teplé vody nedoporučuje.



ROZMĚRY (viz strana 39)



DIAGRAM PRŮTOKU (viz strana 39)

volný průtok



SERVISNÍ DÍLY (viz strana 42)

XXX = Kód povrchové úpravy

000 = Chrom

310 = Brushed Redgold

330 = Polished Black Chrome

820 = Brushed Nickel

930 = Polished Brass



ZVLÁŠTNÍ PŘÍSLUŠENSTVÍ

(viz strana 44)

není součástí dodávky

/ prodloužení 25 mm #13595000

/ prodloužení 33 mm (při malé hloubce zabudování) #14972XXX, #14968XXX, #14961XXX



ČIŠTĚNÍ (viz strana 45)



OVLÁDÁNÍ (viz strana 40)



ZKUŠEBNÍ ZNAČKA (viz strana 46)

PORUCHA	PŘÍČINA	ODSTRANĚNÍ
/ Armatura jde ztěžka	/ Kartuše je vadná, zanesená-vodním kamenem	/ Kartuši vyměnit
/ Armatura odkapává	/ Kartuše je vadná	/ Kartuši vyměnit
/ Přepínač nefunguje	/ Usazeniny	/ Vyčistit přepínač/promazat o-kroužky
	/ příliš malý tlak vody	/ zvýšit tlak vody
	/ přepínač defektní	/ Přepínač vyměnit
/ nízká teplota teplé vody, žádná studená voda průtokový ohřívač naskočí, když se navolí studená voda	/ Špatně nastavená zarážka pro teplou vodu	/ Seřadit zarážku pro teplou vodu
	/ Křížení toků	/ Kartuši vyměnit



△ BEZPEČNOSTNÉ POKYNY

- △ Pri montáži musíte nosiť rukavice, aby ste predišli pomliaždeninám a rezným poraneniam.
- △ Produkt sa smie používať len na kúpanie a telesnú hygienu.
- △ Veľké rozdiely v tlaku medzi prípojkami studenej a teplej vody musia byť vyrovnané.

POKYNY PRE MONTÁŽ

- / Pred montážou musíte produkt skontrolovať, či nebol počas transportu poškodený. Po zabudovaní nebudú uznané žiadne škody spôsobené transportom alebo poškodenia povrchu.
- / Ledningarna och blandaren måste monteras, spolans igenom och kontrolleras enligt de gällande normerna.
- / Je potrebné dodržiavať smernice o inštalácii, ktoré sú práve teraz platné v krajinách.

TECHNICKÉ ÚDAJE

Prevádzkový tlak:	max. 1 MPa
Doporučený prevádzkový tlak:	0,1 - 0,5 MPa
Skúšobný tlak:	1,6 MPa
	(1 MPa = 10 bar = 147 PSI)
Teplota teplej vody:	max. 70°C
Doporučená teplota teplej vody:	65°C
Termická dezinfekcia:	max. 70°C/4 min

Výrobok je koncipovaný výhradne pre pitnú vodu!

POPIS SYMBOLOV



Nepoužívať silikón s obsahom kyseliny octovej!

NASTAVENIE (viď strana 38)

Nastavenie obmedzenia teplej vody. V spojení s prietokovými ohrievačmi sa neodporúča použitie obmedzovača teplej vody.

PORUCHA	PRÍČINA	POMOC
/ Armatúra "chodí" ťažko	/ Kartúša je poškodená, väpenaté usadeniny	/ Vymeniť kartúšu
/ Z armatúry kvapká voda	/ Kartúša je poškodená	/ Vymeniť kartúšu
/ Prepínač nefunguje	/ Usadeniny	/ Vyčistiť prepínač / namazať O krúžky
	/ Príliš malý tlak vody	/ Zvýšiť tlak vody
	/ Prepínač defektný	/ Prepínač vymeniť
/ Málo teplá voda, žiadna studená voda, prietokový ohrievač naskočí, keď sa navolí studená voda.	/ Nesprávne nastavená zádržka na teplú vodu	/ Nastavenie zádržky na teplú vodu
	/ Kríženie tokov	/ Vymeniť kartúšu



ROZMERY (viď strana 39)

DIAGRAM PRIETOKU

(viď strana 39)

volný prietok



SERVISNÉ DIELY (viď strana 42)

XXX = Farebné označenie

000 = Chróm

310 = Brushed Redgold

330 = Polished Black Chrome

820 = Brushed Nickel

930 = Polished Brass



ZVLÁŠTNE PRÍSLUŠENSTVO

(viď strana 44)

nie je súčasťou dodávky

/ Predĺženie 25 mm #13595000

/ Predĺženie 33 mm (pri malej montážnej hĺbke)
#14972XXX, #14968XXX, #14961XXX



ČISTENIE (viď strana 45)



OBSLUHA (viď strana 40)



OSVEDČENIE O SKÚŠKE

(viď strana 46)



△ 安全技巧

- △ 装配时为避免挤压和切割受伤，必须戴上手套。
- △ 本产品只允许作为洗浴、卫生和洁身之用。
- △ 冷热水管间过大的压力差必须予以平衡。

安装提示

- / 安装前必须检查产品是否受到运输损害。安装后将不认可运输损害或表面损伤。
- / 管道和阀门必须根据通用标准进行安装、冲洗和检查。
- / 请遵守当地国家现行的安装规定。

技术参数

- 工作压力: 最大 1 MPa
 推荐工作压力: 0,1 - 0,5 MPa
 测试压强: 1,6 MPa
 (1 MPa = 10 bar = 147 PSI)
- 热水温度: 最大 70°C
 推荐热水温度: 65°C
 热力消毒: 最大 70°C / 4 分钟
 该产品专为饮用水设计！

符号说明



请勿使用含有乙酸的硅胶！



调节 (参见第页 38)

热水温度调节。如果使用即热式喷头，则不建议安装热水阀门。



大小 (参见第页 39)



流量示意图 (参见第页 39)
时的流速



备用零件 (参见第页 42)

XXX = 颜色代码
000 = 镀铬

- 310 = Brushed Redgold
 330 = Polished Black Chrome
 820 = Brushed Nickel
 930 = Polished Brass



选装附件 (参见第页 44)

不在供货范围内

/ 加长 25 mm #13595000

/ 加长件33mm (墙壁不够深时)
#14972XXX, #14968XXX, #14961XXX



清洗 (参见第页 45)



操作 (参见第页 40)



检验标记 (参见第页 46)

问题	原因	补救
/ 龙头不灵活	/ 阀芯损坏、结垢	/ 更换阀芯
/ 龙头滴水	/ 阀芯损坏	/ 更换阀芯
/ 分流器不工作	/ 沉积物	/ 清洁分流器 / 给○形环上油
	/ 水压过低	/ 增加水压
	/ 分流器损坏	/ 更换分流器
/ 热水温度过低，没有冷水。选择冷水时，热水器启动。	/ 温度限制器设置错误	/ 设置温度限制器
	/ 交叉流动	/ 更换阀芯

安装 (参见第页 32) 

△ УКАЗАНИЯ ПО ТЕХНИКЕ БЕЗОПАСНОСТИ

- △ Во время монтажа следует надеть перчатки во избежание прищемления и порезов.
- △ Изделие разрешается использовать только в гигиенических целях: для принятия ванны и личной гигиены.
- △ донного клапа. Перед установкой смесителя необходимо регулировочными кранами выровнять давление холодной и горячей воды при помощи вентилей регулирующих подачу воды в квартиру.

УКАЗАНИЯ ПО МОНТАЖУ

- / Перед монтажом следует проверить изделие на предмет повреждений при перевозке. После монтажа претензии о возмещении ущерба за повреждения при перевозке или повреждения поверхностей не принимаются.
- / Трубы и арматура должны быть установлены, промыты и проверены в соответствии с действующими нормами.
- / Необходимо соблюдать требования по монтажу, действующие в соответствующих странах.

ТЕХНИЧЕСКИЕ ДАННЫЕ

Рабочее давление: не более. 1 МПа
 Рекомендуемое рабочее давление: 0,1 - 0,5 МПа
 Давление: 1,6 МПа
 (1 МПа = 10 bar = 147 PSI)
 Температура горячей воды: не более. 70°C
 Рекомендуемая темп. гор. воды: 65°C
 Термическая дезинфекция: не более. 70°C/4 мин
 Изделие предназначено исключительно для питьевой воды!

ОПИСАНИЕ СИМВОЛОВ



Не применяйте силикон, содержащий уксусную кислоту.



ПОДГОНКА (см. стр. 38)

Регулировка ограничителя горячей воды. В сочетании с проточными нагревателями не рекомендуется использовать блокировку воды.



РАЗМЕРЫ (см. стр. 39)



СХЕМА ПОТОКА (см. стр. 39)
свободное истечение



КОМПЛЕКТ (см. стр. 42)

XXX = Цветная кодировка
 000 = Хром
 310 = Brushed Redgold
 330 = Polished Black Chrome
 820 = Brushed Nickel
 930 = Polished Brass



СПЕЦИАЛЬНЫЕ ПРИНАДЛЕЖНОСТИ (см. стр. 44)

не включено в объем поставки!
 / Удлинение 25 мм #13595000

/ Удлинение 33 мм (при малой глубине установки) #14972XXX, #14968XXX, #14961XXX



ОЧИСТКА (см. стр. 45)



ЭКСПЛУАТАЦИЯ (см. стр. 40)



ЗНАК ТЕХНИЧЕСКОГО КОНТРОЛЯ (см. стр. 46)

НЕИСПРАВНОСТЬ	ПРИЧИНА	УСТРАНЕНИЕ НЕИСПРАВНОСТИ
/ Арматура работает с усилием	/ Картридж неисправен, засорение накипью	/ Замените картридж
/ Арматура протекает	/ Картридж неисправен	/ Замените картридж
/ Переключатель не работает	/ отложения	/ очистите переключатель/смажьте консистентной смазкой кольца круглого сечения
	/ Слишком малое давление воды	/ Увеличьте давление воды
	/ Переключатель неисправен	/ Замените переключатель
/ Слишком низкая температура горячей воды. Проточный нагреватель запускается при выборе холодной воды.	/ Ограничение горячей воды отрегулировано неправильно	/ Отрегулируйте ограничение горячей воды
	/ Перекрестный поток	/ Замените картридж



△ TURVALLISUUSOHJEET

- △ Asennuksessa on käytettävä käsitettä puristumien ja viiltojen aiheuttamien tapaturmien estämiseksi.
- △ Tuotetta saa käyttää ainoastaan kylpy-, hygienia- ja puhdistustarkoituksiin.
- △ Suuret paine-erot kylmä- ja kuumavesiliitännöiden välillä on tasattava.

ASENNUSOHJEET

- / Ennen asennusta on tarkastettava tuotteen mahdolliset kuljetusvahingot. Asennuksen jälkeen kuljetus- ja pintavaurioita ei hyväksytä.
- / Putket ja hana on asennettava, huuhdeltava ja tarkastettava voimassa olevien standardien mukaisesti.
- / Jokaisessa maassa on noudatettava siellä päteviä asennusohjeita.

TEKNISET TIEDOT

Käyttöpaine:	maks. 1 MPa
Suosittelun käyttöpaine:	0,1 - 0,5 MPa
Koestuspaine:	1,6 MPa (1 MPa = 10 bar = 147 PSI)
Kuuman veden lämpötila:	maks. 70°C
Kuuman veden suosituslämpötila:	65°C
Lämpödesinfektio:	maks. 70°C/4 min

Tuote on suunniteltu käytettäväksi ainoastaan juomaveden kanssa!

MERKIN KUVAUS



Älä käytä etikkahappopitoista silikonia!

SÄÄTÖ (katso sivu 38)

Lämpötilan rajoittimen säätäminen. Emme suosittele käyttämään lämpötilan rajoitinta

vedenlämmittimen (läpivirtauskuumennin) yhteydessä.

MITAT (katso sivu 39)



VIRTAUSDIAGRAMMI (katso sivu 39)

vapaa läpivirtaus



VARAOSAT (katso sivu 42)

XXX = Värikoodaus

000 = Kromi

310 = Brushed Redgold

330 = Polished Black Chrome

820 = Brushed Nickel

930 = Polished Brass



ERITYISVARUSTE (katso sivu 44)

ei kuulu toimitukseen

/ Pidennys 25 mm #13595000

/ Pidennys 33 mm (pienemmällä asennussyvyydellä) #14972XXX, #14968XXX, #14961XXX



PUHDISTUS (katso sivu 45)



KÄYTTÖ (katso sivu 40)



KOESTUSMERKKI (katso sivu 46)

HÄIRIÖ

/ Hana on raskaskäyttöinen

/ Hanasta tippuu vettä

/ Valitsin ei toimi

SYY

/ Patruuna rikki, kalkkikerrostumia

/ Patruuna rikki

/ kerrostumia

/ Liian matala vedenpaine

/ Valitsin rikki

/ Lämminveden rajoitin väärin säädetty

/ Ristiinvirtaus

TOIMENPIDE

/ Vaihda patruuna

/ Vaihda patruuna

/ Vaihtimen puhdistus/O-renkaiden rasvaus

/ lisää vedenpainetta

/ Vaihda valitsin

/ Lämminveden lämpötila liian alhainen, ei kylmää vettä. Läpivirtauskuumennin käynnistyy kylmää vettä otettaessa.

/ Säädä lämminveden rajoitin

/ Vaihda patruuna

ASENNUS (katso sivu 32)



△ SÄKERHETSANVISNINGAR

- △ Handskar ska bäras under monteringsarbetet så att man kan undvika kläm- och skärskador.
- △ Produkten får bara användas till kroppshygien med bad och dusch.
- △ Stora tryckskillnader mellan anslutningarna för varmt och kallt vatten måste utjämnas.

MONTERINGSANVISNINGAR

- / Det måste undersökas om produkten har transportskador innan den monteras. Efter monteringen accepteras inga transport- eller ytskiktsskador.
- / Ledningarna och blandaren måste monteras, spolats igenom och kontrolleras enligt de gällande normerna.
- / De installationsriktlinjer som gäller i länderna ska följas.

TEKNISKA DATA

Driftstryck:	max. 1 MPa
Rek. driftstryck:	0,1 - 0,5 MPa
Tryck vid provtryckning:	1,6 MPa
	(1 MPa = 10 bar = 147 PSI)
Varmvattentemperatur:	max. 70°C
Rek. varmvattentemp.:	65°C
Termisk desinfektion:	max. 70°C / 4 min
Produkten är enbart avsedd för dricksvatten!	

SYMBOLFÖRKLARING



Använd inte silikon som innehåller ättiksyra!



JUSTERING (se sidan 38)

Ställa in varmvattenregleringen. Tillsammans med varmvattenberedare rekommenderas inte en varmvattenspärr.



MÄTTEN (se sidan 39)



FLÖDESSCHEMA (se sidan 39)

fri genomströmning



RESERVDELAR (se sidan 42)

XXX = Färgkodning

000 = Krom

310 = Brushed Redgold

330 = Polished Black Chrome

820 = Brushed Nickel

930 = Polished Brass



SPECIALTILLBEHÖR (se sidan 44)

medföljer ej leveransen

/ Förlängning 25 mm #13595000

/ Förlängning 33 mm (vid litet monteringsdjup)
#14972XXX, #14968XXX, #14961XXX



RENGÖRING (se sidan 45)



HANTERING (se sidan 40)



TESTSIGILL (se sidan 46)

STÖRNING

/ Blandare är trög

/ Blandare droppar

/ Omkopplare fungerar inte

/ För låg varmvattentemperatur, inget kallvatten. Varmvattenberedaren slår på när kallvatten väljs.

ORSAK

/ Patron defekt, förkalkad

/ Patron defekt

/ Avlagringar

/ För lågt vattentryck

/ Omkopplare defekt

/ Varmvattenreglering felaktigt inställd

/ Korsflöde

ÅTGÄRD

/ Byt ut patron

/ Byt ut patron

/ Rengör omkastare/smörj O-ringar

/ Öka vattentrycket

/ Byt ut omkopplare

/ Ställ in varmvattenreglering

/ Byt ut patron



△ SAUGUMO TECHNIKOS NURODYMAI

- △ Apsaugai nuo užspaudimo ir įsijovimo montavimo metu mūvėkite pirštines.
- △ Gaminys turi būti naudojamas tik maudymuisi, kūno higienai ir švarai palaikyti.
- △ Turi būti išlyginti šalto ir karšto slėgio nelygumai.

MONTAVIMO INSTRUKCIJA

- / Prieš montuojant būtina patikrinti, ar gaminys nebuvo pažeistas transportavimo metu. Sumontavus pretenzijos dėl transportavimo ir paviršiaus pažeidimų nepriimamos.
- / Vamzdžiai ir sujungimai turi būti montuojami, plaunami ir tikrinami pagal galiojančias normas.
- / Laikykitės atitinkamoje šalyje galiojančių direktyvų dėl įrengimo.

TECHNINIAI DUOMENYS

- Darbinis slėgis: ne daugiau kaip 1 MPa
 Rekomenduojamas slėgis: 0,1 - 0,5 MPa
 Bandomasis slėgis: 1,6 MPa
 (1 MPa = 10 barų = 147 PSI)
- Karšto vandens temperatūra: ne daugiau kaip 70°C
 Rekomenduojama karšto vandens temperatūra: 65°C
 Terminis dezinfekavimas: ne daugiau kaip 70°C / 4 min
 Produktas skirtas tik geriamajam vandeniui!

SIMBOLIO APRAŠYMAS



Nenaudokite silikono, kurio sudėtyje yra acto rūgšties!



REGULIAVIMAS (žr. psl. 38)

Karšto vandens ribojimas. Kartu su cirkuliaciniais šildytuvais nerekomenduojama naudoti karšto vandens blokavimo įtaisų.



IŠMATAVIMAI (žr. psl. 39)



PRALAUDIMO DIAGRAMA (žr. psl. 39)

laisvas vandens pralaidumas



ATSARGINĖS DALYS (žr. psl. 42)

- XXX = Spalvos
- 000 = Chrom
- 310 = Brushed Redgold
- 330 = Polished Black Chrome
- 820 = Brushed Nickel
- 930 = Polished Brass



SPECIALŪS PRIEDAI (žr. psl. 44)
nėra pridama

/ Ilgiklis 25 mm #13595000

/ Ilgiklis 33 mm (esant nepakankamam sienos gyliui) #14972XXX, #14968XXX, #14961XXX



VALYMAS (žr. psl. 45)



EKSPLOATACIJA (žr. psl. 40)



BANDYMO PAŽYMA (žr. psl. 46)

GEDIMAS

- / Sunkiai sukiojama rankenėlė
- / Maišytuvus praleidžia vandenį
- / Perjungėjas nefunkcionuoja

PRIEŽASTIS

- / Kasetė pažeista, užkalkėjusi
- / Kasetė pažeista
- / Apnašos
- / Nepakankamas vandens spaudimas
- / Pažeistas perijungėjas
- / Neteisingai nustatytas karšto vandens ribotuvus
- / Kryžminė srovė

PRIEMONĖ

- / Pakeisti kasetę
- / Pakeisti kasetę
- / Išvalykite atsukimą/sutepkite O-žiedus
- / Pakelti vandens spaudimą
- / Pakeisti perijungėją
- / Nustatyti karšto vandens ribotuvą
- / Pakeisti kasetę

- / Per maža karšto vandens temperatūra, nėra šalto vandens. Momentinis pašildytavas pradeda veikti, kai naudojamas šalta vanduo



△ SIGURNOSNE UPUTE

- △ Prilikom montaže se radi sprječavanja prignječenja i posjekotina moraju nositi rukavice.
- △ Proizvod se smije primjenjivati samo za kupanje, tuširanje i osobnu higijenu.
- △ Velika razlika u pritisku između vruće i hladne vode mora biti izbalansirana.

UPUTE ZA MONTAŽU

- / Prije montaže mora se provjeriti je li proizvod oštećen prilikom transporta. Nakon ugradnje se ne priznaju nikakve reklamacije koje se odnose na površinska i transportna oštećenja.
- / Cijevi i armatura moraju biti postavljeni, isprani i testirani prema važećim normama.
- / Obvezno se moraju uvažiti propisi o instalacijama koji vrijede u dotičnoj zemlji.

TEHNIČKI PODATCI

Najveći dopušteni tlak:	tlak 1 MPa
Preporučeni tlak:	0,1 - 0,5 MPa
Probni tlak:	1,6 MPa
	(1 MPa = 10 bar = 147 PSI)
Temperatura vruće vode:	tlak 70°C
Preporučena temperatura vruće vode:	65°C
Termička dezinfekcija:	tlak 70°C / 4 min
Proizvod je koncipiran isključivo za pitku vodu!	

OPIS SIMBOLA

Nemojte koristiti silikon koji sadrži octenu kiselinu!



REGULACIJA (pogledaj stranicu 38)

Namještanje limitera tople vode. U kombinaciji s protočnim bojlerima nije preporučljiva primjena sustava za blokiranje dotoka tople vode.



MJERE (pogledaj stranicu 39)



DIJAGRAM PROTOKA

(pogledaj stranicu 39)

slobodan protok



REZERVNI DJELOVI

(pogledaj stranicu 42)

XXX = Boje

000 = Krom

310 = Brushed Redgold

330 = Polished Black Chrome

820 = Brushed Nickel

930 = Polished Brass



POSEBNI PRIBOR

(pogledaj stranicu 44)

Nije sadržano u isporuci!

/ Produljenje 25 mm #13595000

/ Produljenje 33 mm (kod manje dubine ugradnje) #14972XXX, #14968XXX, #14961XXX



ČIŠĆENJE (pogledaj stranicu 45)



UPOTREBA (pogledaj stranicu 40)



OZNAKA TESTIRANJA

(pogledaj stranicu 46)

GREŠKA	UZROK	OTKLANJANJE
/ Ručica se zaglavila	/ Neispravan uložak	/ Taloženje kamenca
/ Slavina kaplje	/ Neispravan uložak	/ Zamijenite uložak
/ Selektor ne radi	/ Naslage	/ Čišćenje selektora i podmazivanje O-prstenova
	/ Prenizak tlak vode	/ Povećajte tlak vode
	/ Selektor je neispravan	/ Zamijenite selektor
/ Preniska temperatura vruće vode, nedostatak hladne vode. Protočni bojler se pali pri podešenoj funkciji za protok hladne vode	/ Limiter vruće vode nije dobro podešen	/ Podesite limiter vruće vode
	/ Križni tok vode	/ Zamijenite uložak



△ GÜVENLİK UYARILARI

- △ Montaj esnasında ezilme ve kesilme gibi yaralanmaları önlemek için eldiven kullanılmalıdır.
- △ Ürün yalnızca banyo, hijyen ve beden temizliği amaçları doğrultusunda kullanılabilir.
- △ Sıcak ve soğuk su bağlantıları arasında büyük basınç farklılıkları varsa, bu basınç farklılıklarının dengelenmesi gerekir.

MONTAJ AÇIKLAMALARI

- / Montaj işleminden önce ürün nakliye hasarları yönünden kontrol edilmelidir. Montaj işleminden sonra nakliye veya yüzey hasarları için sorumluluk üstlenilmemektedir.
- / Boruların ve armatürün montajı, yıkanması ve kontrolü geçerli normlara göre yapılmalıdır.
- / Ülkelerde geçerli kurulum yönetmeliklerine riayet edilmelidir.

TEKNİK BİLGİLER

İşletme basıncı:	azami 1 MPa
Tavsiye edilen işletme basıncı:	0,1 - 0,5 MPa
Kontrol basıncı:	1,6 MPa (1 MPa = 10 bar = 147 PSI)
Sıcak su sıcaklığı:	azami 70°C
Tavsiye edilen su ısı:	65°C
Termik dezenfeksiyon:	azami 70°C/4 dak
Ürün sadece şebeke suyu için tasarlanmıştır!	

SİMGE AÇIKLAMASI



Asetik asit içeren silikon kullanmayın!



AYARLAMA (bakınız sayfa 38)

Sıcak su sınırlamasının ayarlanması. Sıcak su kilidinin sürekli ısıtıcıyla kullanılması tavsiye edilmez.



ÖLÇÜLERİ (bakınız sayfa 39)



AKIŞ DİYAGRAMI (bakınız sayfa 39)
serbest akış



YEDEK PARÇALAR (bakınız sayfa 42)

XXX = Renkler
000 = Krom
310 = Brushed Redgold
330 = Polished Black Chrome
820 = Brushed Nickel
930 = Polished Brass



ÖZEL AKSESUARLAR

(bakınız sayfa 44)

Teslimat kapsamına dahil değildir

/ Uzatma 25 mm #13595000

/ Uzatma 33 mm (montaj derinliği düşükken)
#14972XXX, #14968XXX, #14961XXX



TEMİZLEME (bakınız sayfa 45)



KULLANIMI (bakınız sayfa 40)



KONTROL İŞARETİ
(bakınız sayfa 46)

ARIZA	SEBEP	YARDIM
/ Batarya kullanımı ağırlaşıyor	/ Kartuş Bozulmuş ve kireçlenmiş olabilir	/ Kartuşu değiştirin
/ Batarya su damlatıyor	/ Kartuş bozuk olabilir	/ Kartuşu değiştirin
/ Divertör çalışmıyor	/ Çökelmeler	/ Dönüştürücüyü temizleme/O ringleri yağlama
	/ Su basıncı düşük	/ Su basıncını artırın
	/ Divertör arızalı	/ Divertörü değiştirin
/ Sıcak su sıcaklığı çok düşük, soğuk su yok. Soğuk su seçilince şofben çalışmaya başlıyor.	/ Isı limitleyici düzgün çalışmıyor	/ Isı limitleyiciyi yeniden ayarlayın
	/ Çapraz akış	/ Kartuşu değiştirin



△ INSTRUCȚIUNI DE SIGURANȚĂ

- △ La montare utilizați mănuși pentru evitarea contuziunilor și tăierii mâinilor.
- △ Produsul poate fi utilizat doar pentru spălarea, menținerea igienei și curățarea corpului.
- △ Diferențele de presiune mari între alimentarea cu apă rece și apă caldă trebuie echilibrate.

INSTRUCȚIUNI DE MONTARE

- / Înainte de instalare verificați, dacă produsul prezintă deteriorări de transport. După instalare garanția nu acoperă deteriorările de transport și cele de suprafață.
- / Conductele și bateriile trebuie montate, spălate și verificate conform normelor în vigoare.
- / Respectați reglementările referitoare la instalare valabile în țara respectivă.

DATE TEHNICE

Presiune de funcționare:	max. 1 MPa
Presiune de funcționare recomandată:	0,1 - 0,5 MPa
Presiune de verificare:	1,6 MPa (1 MPa = 10 bar = 147 PSI)
Temperatura apei calde:	max. 70°C
Temperatura recomandată a apei calde:	65°C
Dezinfecție termică:	max. 70°C/4 min

Produsul este destinat exclusiv pentru apă potabilă.

DESCRIEREA SIMBOLURILOR



Nu utilizați silicon cu conținut de acid acetic!



REGLARE (vezi pag. 38)

Reglarea limitatorului de apă caldă. Nu se recomandă folosirea unui limitator de apă caldă în combinație cu un boiler instant.



DIMENSIUNI (vezi pag. 39)

DIAGRAMA DE DEBIT

(vezi pag. 39)

debit cu curgere liberă



PIESE DE SCHIMB (vezi pag. 42)

XXX = Coduri de culori

000 = Crom

310 = Brushed Redgold

330 = Polished Black Chrome

820 = Brushed Nickel

930 = Polished Brass



ACCESORII OPȚIONALE

(vezi pag. 44)

nu este inclus în setul livrat

/ Prolungitor 25 mm #13595000

/ Prolungitor 33 mm (în cazul montării la adâncime mică) #14972XXX, #14968XXX, #14961XXX



CURĂȚARE (vezi pag. 45)



UTILIZARE (vezi pag. 40)



CERTIFICAT DE TESTARE

(vezi pag. 46)

DERANJAMENT	CAUZA	MĂSURI DE REMEDIERE
/ Bateria se mișcă dificil	/ Cartuș defect din cauza depunerilor de calcar	/ Schimbați cartușul.
/ Bateria picură	/ Cartuș defect	/ Schimbați cartușul.
/ Cartușul nu funcționează.	/ Depuneri	/ Curățați inversorul/ ungeți inelele O
	/ Presiune apă prea mică	/ Măriți presiunea de apă
	/ Cartuș defect	/ Schimbați cartușul.
/ Temperatura apei este prea mică, nu este apă rece. Boilerul instant pornește când se dă drumul la apa rece	/ Limitarea temperaturii apei calde setată incorect.	/ Setați limitarea temperaturii apei calde.
	/ Curgere încrucișată (apa rece în intră în conducta de apă caldă și invers)	/ Schimbați cartușul.

MONTARE (vezi pag. 32)



ΔΥΠΟΔΕΙΞΕΙΣ ΑΣΦΑΛΕΙΑΣ

- Δ Για να αποφύγετε τραυματισμούς κατά τη συναρμολόγηση πρέπει να φοράτε γάντια.
- Δ Το προϊόν επιτρέπεται να χρησιμοποιείται μόνο σαν μέσο λουτρού, υγιεινής και καθαρισμού του σώματος.
- Δ Οι διαφορές της πίεσης μεταξύ της σύνδεσης κρύου και ζεστού νερού θα πρέπει να αντισταθμίζονται.

ΟΔΗΓΙΕΣ ΣΥΝΑΡΜΟΛΟΓΗΣΗΣ

- / Πριν τη συναρμολόγηση πρέπει να εξεταστεί το προϊόν για ζημιές μεταφοράς. Μετά την εγκατάσταση δεν αναγνωρίζονται ζημιές από τη μεταφορά ή επιφανειακές ζημιές.
- / Οι σωλήνες και η μπαταρία πρέπει να τοποθετηθούν σύμφωνα με τα ισχύοντα πρότυπα, να τεθούν υπό πίεση και να δοκιμαστούν.
- / Θα πρέπει να τηρούνται οι οδηγίες εγκατάστασης που ισχύουν σε κάθε κράτος.

ΤΕΧΝΙΚΑ ΧΑΡΑΚΤΗΡΙΣΤΙΚΑ

- Λειτουργία πίεσης: έως 1 MPa
 Συνιστώμενη λειτουργία πίεσης: 0,1 - 0,5 MPa
 Πίεση ελέγχου: 1,6 MPa
 (1 MPa = 10 bar = 147 PSI)
- Θερμοκρασία ζεστού νερού: έως 70°C
 Συνιστώμενη θερμοκρασία ζεστού νερού: 65°C
 Θερμική απολύμανση: έως 70°C / 4 min
 Το προϊόν έχει σχεδιαστεί αποκλειστικά για πόσιμο νερό!

ΠΕΡΙΓΡΑΦΗ ΣΥΜΒΟΛΩΝ



Μην χρησιμοποιείτε σιλικόνη που περιέχει οξικό οξύ!



ΡΥΘΜΙΣΗ (βλ. Σελίδα 38)

Ρύθμιση του δοσομετρητή ζεστού νερού. Δεν συνιστάται η διάταξη φραγής ζεστού νερού σε συνδυασμό με ταχυθερμοσίφωνα.



ΔΙΑΣΤΑΣΕΙΣ (βλ. Σελίδα 39)



ΔΙΑΓΡΑΜΜΑ ΡΟΗΣ (βλ. Σελίδα 39)

Ελεύθερη ροή



ΑΝΤΑΛΛΑΚΤΙΚΑ (βλ. Σελίδα 42)

XXX = Χρώματα

000 = Επιχρωμωμένο

310 = Brushed Redgold

330 = Polished Black Chrome

820 = Brushed Nickel

930 = Polished Brass



ΕΙΔΙΚΑ ΑΞΕΣΟΥΑΡ (βλ. Σελίδα 44)

δεν περιλαμβάνεται στον παραδοτέο εξοπλισμό

/ Επιμήκυνση 25 mm #13595000

/ Σωλήνας επιμήκυνσης 33 mm (σε μειωμένο βάθος τοποθέτησης) #14972XXX, #14968XXX, #14961XXX



ΚΑΘΑΡΙΣΜΟΣ (βλ. Σελίδα 45)



ΧΕΙΡΙΣΜΟΣ (βλ. Σελίδα 40)



ΣΗΜΑ ΕΛΕΓΧΟΥ (βλ. Σελίδα 46)

ΒΛΑΒΗ

- / Σκληρή μπαταρία (μείκτης)
- / Η μπαταρία στάζει
- / Ο διακόπτης επιλογής δεν λειτουργεί

ΑΙΤΙΑ

- / Ελαττωματικό φυσίγγιο, άλατα
- / Ελαττωματικό φυσίγγιο
- / Άλατα
- / Ανεπαρκής πίεση νερού
- / Βλάβη στο διακόπτη επιλογής
- / Λάθος ρύθμιση της περιοριστικής διάταξης ζεστού νερού
- / Σταυροειδής ροή

ΔΙΟΡΘΩΣΗ

- / Αλλαγή φυσιγγίου
- / Αλλαγή φυσιγγίου
- / Καθαρίστε τον ρυθμιστή νερού/ λιπάνετε τους στεγανωτικούς δακτυλίους
- / Αυξήστε την πίεση του νερού
- / Αλλάξτε το διακόπτη επιλογής
- / Ρυθμίστε την περιοριστική διάταξη του ζεστού νερού
- / Αλλαγή φυσιγγίου

- / Χαμηλή θερμοκρασία ζεστού νερού, καθόλου κρύο νερό. Ο ταχυθερμοσίφωνα ενεργοποιείται, όταν επιλέγεται το κρύο νερό.



△ VARNOSTNA OPOZORILA

- △ Pri montaži je treba nositi rokavice, da se preprečijo poškodbe zaradi zmečkanja ali urezov.
- △ Ta izdelek se sme uporabljati le z namenom umivanja, vzdrževanja higiene in telesne nege.
- △ Velike razlike v tlaku med priključkom za mrzlo in priključkom za toplo vodo je potrebno izravnati.

NAVODILA ZA MONTAŽO

- / Pred montažo je treba izdelek preveriti glede morebitnih transportnih poškodb. Po vgradnji transportne ali površinske poškodbe ne bodo več priznane.
- / Cevi in armaturo je treba montirati, izprati in preveriti po veljavnih standardih.
- / Upoštevati je treba pravilnike o inštalacijah, ki veljajo v posamezni državi.

TEHNIČNI PODATKI

Delovni tlak:	maks. 1 MPa
Priporočeni delovni tlak:	0,1 - 0,5 MPa
Preskusni tlak:	1,6 MPa (1 MPa = 10 bar = 147 PSI)
Temperatura tople vode:	maks. 70°C
Priporočena temperatura tople vode:	65°C
Termična dezinfekcija:	maks. 70°C/4 min

Proizvod je zasnovan izključno za sanitarno vodo!

OPIS SIMBOLA

Ne smete uporabiti silikona, ki vsebuje ocatno kislino!



JUSTIRANJE (glejte stran 38)

Nastavitev omejevalnika tople vode. V povezavi s pretočnimi grelniki uporaba zapore tople vode ni priporočljiva.



MERE (glejte stran 39)

DIAGRAM PRETOKA

(glejte stran 39)

prost pretok



REZERVNI DELI (glejte stran 42)

XXX = Barve

000 = Krom

310 = Brushed Redgold

330 = Polished Black Chrome

820 = Brushed Nickel

930 = Polished Brass



POSEBEN PRIBOR (glejte stran 44)

Ni vključeno

/ Podaljšek 25 mm #13595000

/ Podaljšek 33 mm (če zid ni dovolj globok)
#14972XXX, #14968XXX, #14961XXX



ČIŠČENJE (glejte stran 45)



UPRAVLJANJE (glejte stran 40)



PRESKUSNI ZNAK (glejte stran 46)

NAPAKA	VZROK	POMOČ
/ Težko premikanje armature	/ Pokvarjen vložek, poapneno	/ Zamenjajte vložek
/ Iz armature kaplja	/ Pokvarjen vložek	/ Zamenjajte vložek
/ Preklopnik ne deluje	/ Obloge	/ Očistite premičnik / namastite obročno tesnilo
	/ Prenizek vodni tlak	/ Povečajte vodni tlak
	/ Preklopnik je pokvarjen	/ Zamenjajte preklopnik
/ Prenizka temperatura tople vode, ni mrzle vode. Pretočni grelnik se sproži, kadar izberete mrzlo vodo.	/ Omejevalnik tople vode ni pravilno nastavljen	/ Nastavite omejevalnik tople vode
	/ Križni tok	/ Zamenjajte vložek

MONTAŽA (glejte stran 32)



△ OHUTUSJUHISED

- △ Kandke paigaldamisel muljumis- ja löikevigastuste vältimiseks kindaid.
- △ Toodet tohib kasutada ainult pesemis-, hügieeni- ja kehapuhastamiseesmärkidel.
- △ Kui külma ja kuuma vee ühenduste surve on väga erinev, tuleb need tasakaalustada.

PAIGALDAMISJUHISED

- / Enne paigaldamist tuleb toodet kontrollida transpordikahjustuste osas. Pärast paigaldamist ei tunnustata enam transpordi- või pinnakahjustuste kaebuseid.
- / Voolikute ja segisti paigaldamisel, loputamisel ja kontrollimisel tuleb lähtuda kehtivatest normatiividest.
- / Vastavas riigis kehtivaid paigalduseeskirju tuleb järgida.

TEHNILISED ANDMED

Töörõhk	maks. 1 MPa
Soovitatav töörõhk:	0,1 - 0,5 MPa
Kontrollsurve:	1,6 MPa (1 MPa = 10 baari = 147 PSI)
Kuuma vee temperatuur:	maks. 70°C
Soovitatav kuuma vee temperatuur:	65°C
Terminline desinfektsioon:	maks. 70°C/4 min

Toode on ette nähtud eranditult joogivee jaoks!

SÜMBOLITE KIRJELDUS



Ärge kasutage äädikhapet sisaldavat silikooni!



REGULEERIMINE (vt lk 38)

Sooja vee piirangu seadistamine. Ühenduses boileritega ei ole sooja vee blokeeringu soovitatav.



MÕÕTUDE (vt lk 39)

LÄBIVOOLUDIAGRAMM (vt lk 39)
ärvavoolu surve



VARUOSAD (vt lk 42)

XXX = Värvid
000 = Kroom
310 = Brushed Redgold
330 = Polished Black Chrome
820 = Brushed Nickel
930 = Polished Brass



SPETSIAALNE LISAVARUSTUS (vt lk 44)

ei sisaldu komplektis

/ pikendus 25 mm #13595000

/ pikendus 33 mm (kui sein ei ole piisavalt paks)
#14972XXX, #14968XXX, #14961XXX



PUHASTAMINE (vt lk 45)



KASUTAMINE (vt lk 40)



KONTROLLSERTIFIKAAT (vt lk 46)

RIKE	PÕHJUS	LAHENDUS
/ Segisti käib raskelt	/ Tööelement on katkine, lubjastunud	/ Vahetage tööelement
/ Segisti tilgub	/ Tööelement on katkine	/ Vahetage tööelement
/ Ümberlüüti ei tööta	/ Setted	/ Ümberlüüti puhastamine/O-tihendite määrimine
	/ Vee surve liiga madal	/ Tõstke vee survet
	/ Ümberlüüti defektne	/ Ümberlüüti välja vahetada
/ Liiga madal sooja vee temperatuur, külma vett pole. Läbivoolu boiler hakkab tööle, kui on valitud külm vesi.	/ Kuuma vee piirang valesti seatud	/ Seadke kuuma vee piirang
	/ Ristvool	/ Vahetage tööelement



△ DROŠĪBAS NORĀDES

- △ Montāžas laikā, lai izvairītos no saspiedumiem un iegrīezumiem, nepieciešams nēsāt cimdus.
- △ Šo produktu drīkst izmantot tikai, lai mazgātos, higiēnai un ķermeņa tīrīšanai.
- △ Jāizlīdzina spiediena atšķirības starp aukstā un karstā ūdens pievadiem.

NORĀDĪJUMI MONTĀŽAI

- / Pirms montāžas nepieciešams pārbaudīt, vai produktam transportēšanas laikā nav radušies bojājumi. Pēc iebūvēšanas bojājumi, kas radušies transportēšanas laikā, vai virsmas bojājumi netiek atzīti.
- / Caurulvadi un armatūra ir jāuzstāda, jāizskalo un jāpārbauda saskaņā ar spēkā esošajiem standartiem.
- / Jāievēro attiecīgās valsts spēkā esošās montāžas prasības.

TEHNISKIE DATI

Darba spiediens:	maks. 1 MPa
Ieteicamais darba spiediens:	0,1 - 0,5 MPa
Pārbaudes spiediens:	1,6 MPa (1 MPa = 10 bar = 147 PSI)
Karstā ūdens temperatūra:	maks. 70°C
Ieteicamā karstā ūdens temperatūra:	65°C
Termiskā dezinfekcija:	maks. 70°C / 4 min

Izstrādājums ir paredzēts tikai dzeramajam ūdenim!

SIMBOLU NOZĪME



Neizmantot silikonu, kas satur etiķskābi!

IEREGULĒŠANA (skat. lpp. 38)

Karsta ūdens ierobežotāja regulēšana. Kopā ar caurteces sildītājiem nav ieteicams izmantot ūdens bloķētāju.



IZMĒRUS (skat. lpp. 39)



CAURPLŪDES DIAGRAMMA
(skat. lpp. 39)

brīva caurplūde



REZERVES DAĻAS (skat. lpp. 42)

XXX = Krāsu kodi

000 = Hroma

310 = Brushed Redgold

330 = Polished Black Chrome

820 = Brushed Nickel

930 = Polished Brass



SPECIĀLI AKSESUĀRI

(skat. lpp. 44)

komplektā netiek piegādāts

/ Pagarinājums 25 mm #13595000

/ Pagarinājums 33 mm (ja iebūvēšanas dziļums nav pietiekams) #14972XXX, #14968XXX, #14961XXX



TĪRĪŠANA (skat. lpp. 45)



LIETOŠANA (skat. lpp. 40)



PĀRBAUDES ZĪME (skat. lpp. 46)

TRAUCĒJUMS

/ Jaucējkrāns smagi grozāms

/ Iaucējkrāns pil

/ Pārslēdzējs nestrādā

IEMESLS

/ Bojāta kartuša, aizkalķojusies

/ Bojāta kartuša

/ Nogulsnes

/ Nepietiekams ūdens spiediens

/ Bojāts pārslēdzējs

/ Nepareizi noregulāta karstā ūdens bloķēšana

/ Ūdens sajaukšanās

BOJĀJUMU NOVĒRŠANA

/ Nomainīt kartušu

/ Nomainīt kartušu

/ Tīriet pārslēdzēju / eļļojiet blīvējošos gredzenus

/ Paaugstināt ūdens spiedienu

/ Nomainīt pārslēdzēju

/ Pārāk zema ūdens temperatūra, nav aukstā ūdens, izvēloties auksto ūdeni, sāk darboties caurteces sildītājs

/ Noregulēt karstā ūdens ierobežošanu

/ Nomainīt kartušu



△ SIGURNOSNE NAPOMENE

- △ Prilikom montaže se radi sprečavanja prignječenja i posekotina moraju nositi rukavice.
- △ Proizvod sme da se koristi samo za kupanje, tuširanje i ličnu higijenu.
- △ Velika razlika u pritisku između vruće i hladne vode mora biti izbalansirana.

INSTRUKCIJE ZA MONTAŽU

- / Pre montaže se mora proveriti da li je proizvod oštećen pri transportu. Nakon ugradnje se ne priznaju nikakve reklamacije koje se odnose na površinska i transportna oštećenja.
- / Vodovi i armatura moraju biti postavljeni, isprani i testirani prema važećim normama.
- / Treba se pridržavati propisa koji u određenim zemljama važe za instalacije.

TEHNIČKI PODACI

Radni pritisak:	maks. 1 MPa
Preporučeni radni pritisak:	0,1 - 0,5 MPa
Probni pritisak:	1,6 MPa
	(1 MPa = 10 bar = 147 PSI)
Temperatura vruće vode:	maks. 70°C
Preporučena temperatura vruće vode:	65°C
Termička dezinfekcija:	maks. 70°C / 4 min
Proizvod je koncipiran isključivo za pijaću vodu!	

OPIS SIMBOLA



Nemojte koristiti silikon koji sadrži sircetnu kiselinu!



PODEŠAVANJE (vidi stranu 38)

Podešavanje ograničivača tople vode. U kombinaciji sa protočnim bojlerima ne

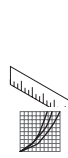

preporučuje se primena sistema za blokiranje dotoka tople vode.

MERE (vidi stranu 39)

DIJAGRAM PROTOKA

(vidi stranu 39)

slobodan protok



REZERVNI DELOVI (vidi stranu 42)

XXX = Oznake boja

000 = Hrom

310 = Brushed Redgold

330 = Polished Black Chrome

820 = Brushed Nickel

930 = Polished Brass



POSEBAN PRIBOR (vidi stranu 44)

Nije sadržano u isporuci

/ Produžetak 25 mm #13595000

/ Produžetak 33 mm (kod manje dubine ugradnje) #14972XXX, #14968XXX, #14961XXX



ČIŠĆENJE (vidi stranu 45)



RUKOVANJE (vidi stranu 40)



ISPITNI ZNAK (vidi stranu 46)

SMETNJA	UZROK	POMOĆ
/ Ručica se zaglavila	/ Neispravna kartuša, nataloženi kamenac	/ Zamenite kartušu
/ Slavina kaplje	/ Neispravna kartuša	/ Zamenite kartušu
/ Preusmerivač ne radi	/ Naslage	/ Čišćenje preusmerivača i podmazivanje O-prstenova
	/ Prenizak pritisak vode	/ Povećajte pritisak vode
	/ Preusmerivač je neispravan	/ Zamenite preusmerivač
/ Preniska temperatura tople vode, nema hladne vode. Protočni bojler se pali iako je pušten hladna voda.	/ Ograničivač vruće vode nije dobro podešen	/ Podesite ograničivač vruće vode
	/ Ukršteni tok vode	/ Zamenite kartušu

△ SIKKERHETSHENVISNINGER

- △ Bruk hansker under montasjen for å unngå klem- og kuttskader.
- △ Produktet skal kun brukes for bade-, hygiene- og kroppshygiene.
- △ Store trykkdifferanser mellom kaldt- og varmtvannstilkoblinger skal utlignes.

MONTAGEHENVISNINGER

- / Før montasjen skal produktet sjekkes for transportskader. Etter monteringen aksepteres ikke noen transport- eller overflateskader.
- / Ledningene og armaturen skal monteres, spyles og sjekkes iht. de gyldige normer.
- / Gjeldende retningslinjer for rørleggerarbeid i de enkelte land skal følges.

TEKNISKE DATA

Driftstrykk	maks. 1 MPa
Anbefalt driftstrykk:	0,1 - 0,5 MPa
Prøvetrykk	1,6 MPa
	(1 MPa = 10 bar = 147 PSI)
Varmtvannstemperatur	maks. 70°C
Anbefalt temperatur for varmt vann	65°C
Termisk desinfisering:	maks. 70°C/4 min
Produktet er utelukkende designet for drikkevann!	

SYMBOLBESKRIVELSE



Ikke bruk silikon som inneholder eddiksyre!



JUSTERING (se side 38)

Innstilling av varmtvannsbegrensning. I forbindelse med gjennomstrømningsvarmere er det ikke anbefalt å bruke en varmtvannspërre.



MÅL (se side 39)

GJENNOMSTRØMNINGSDIAGRAM (se side 39)

fri gjennomstrømning



SERVICEDELER (se side 42)

XXX = Fargekode

000 = Krom

310 = Brushed Redgold

330 = Polished Black Chrome

820 = Brushed Nickel

930 = Polished Brass



EKSTRATILBEHØR (se side 44)

ikke med i leveransen

/ Forlengelse 25 mm #13595000

/ Forlengelse 33 mm (ved liten montasjebybde)
#14972XXX, #14968XXX, #14961XXX



RENGJØRING (se side 45)



BETJENING (se side 40)



PRØVEMERKE (se side 46)

FEIL	ÅRSAK	FEILRETTELSE
/ Armatur ikke lett bevegelig	/ Kartusj defekt, forkalkning	/ Kartusj byttes
/ Armatur drypper	/ Kartusj defekt	/ Kartusj byttes
/ Omstiller fungerer ikke	/ Avleiringer	/ Rengjøre omstiller/smøre O-ringer
	/ For lavt vanntrykk	/ Øke vanntrykk
	/ Omstiller defekt	/ Omstiller byttes
/ For lav varmtvannstemperatur, ikke noe kaldtvann. gjennomstrømningsvarmerer slår seg på når det velges kaldt vann.	/ Varmtvannsbegrensning er feil innstilt	/ Varmtvannsbegrensning innstilles
	/ Krysstrømning	/ Kartusj byttes



△ УКАЗАНИЯ ЗА БЕЗОПАСНОСТ

- △ При монтажа трябва да се носят ръкавици, за да се избегнат наранявания поради притискане или порязване.
- △ Позволено е използването на продукта само за къпане, хигиена и цели на почистване на тялото.
- △ Големите разлики в налягането между изводите за студената и топлата вода трябва да се изравняват.

УКАЗАНИЯ ЗА МОНТАЖ

- / Преди монтажа продуктът трябва да се провери за транспортни щети. След монтажа не се признават транспортни или повърхностни щети.
- / Тръбопроводите и арматурата трябва да се монтира, промият и проверят в съответствие с валидните норми.
- / Трябва да бъдат спазвани валидните в съответните страни предписания за инсталиране.

ТЕХНИЧЕСКИ ДАННИ

Работно налягане:	макс. 1 МПа
Препоръчително работно налягане:	0,1 - 0,5 МПа
Контролно налягане:	1,6 МПа
	(1 МПа = 10 bar = 147 PSI)
Температура на горещата вода:	макс. 70°C
Препоръчителна температура на горещата вода:	65°C
Термична дезинфекция:	макс. 70°C / 4 мин
Продуктът е разработен само за питейна вода!	

ОПИСАНИЕ НА СИМВОЛИТЕ



Не използвайте силикон, съдържащ оцетна киселина!



ЮСТИРАНЕ (вижте стр. 38)

Настройка на ограничителя за топлата вода. Във връзка с проточни нагреватели не се препоръчва блокировка за топлата вода



РАЗМЕРИ (вижте стр. 39)

ДИАГРАМА НА ПОТОКА

(вижте стр. 39)

свободен поток



СЕРВИЗНИ ЧАСТИ (вижте стр. 42)

XXX = Цветово кодиране

000 = Хром

310 = Brushed Redgold

330 = Polished Black Chrome

820 = Brushed Nickel

930 = Polished Brass



СПЕЦИАЛНИ ПРИНАДЛЕЖНОСТИ (вижте стр. 44)

не се съдържа в обема на доставка

/ Удължител 25 мм #13595000

/ Удължител 33 мм (при малка монтажна дълбочина) #14972XXX, #14968XXX, #14961XXX



ПОЧИСТВАНЕ (вижте стр. 45)



ОБСЛУЖВАНЕ (вижте стр. 40)



КОНТРОЛЕН ЗНАК (вижте стр. 46)

НЕИЗПРАВНОСТ

ПРИЧИНА

ПОМОЩ

/ Трудно подвижна арматура	/ Дефектна гилза, покрита с варовик	/ Сменете гилзата
/ Арматурата капее	/ Дефектна гилза	/ Сменете гилзата
/ Превключвателят не функционира	/ Отлагания	/ Почистете превключвателя / Смажете O-образните пръстени
	/ Твърде малко налягане на водата	/ Повишаване на налягането на водата
	/ Дефектен превключвател	/ Сменете превключвателя
/ Твърде ниска температура на топлата вода, няма студена вода.	/ Ограничението за топлата вода е грушно настроено	/ Настройте ограничението за топлата вода
Проточният нагревател се задейства, когато се избере студена вода	/ Кръстосване на потока	/ Сменете гилзата



△ UDHËZIME SIGURIE

- △ Për të evituar lëndimet e pickimeve ose të prerjeve gjatë procesit të montimit duhet që të vishni doreza.
- △ Produkti duhet të përdoret vetëm qëllimet e banjave, të higjienës dhe të larjes së trupit.
- △ Ndryshimet e mëdha të presionit mes lidhjeve të ujit të ftohtë dhe atij të ngrohtë duhen ekuilibruar.

UDHËZIME PËR MONTIMIN

- / Përpara montimit duhet që produkti të kontrollohet për dëmtime nga transporti. Pas instalimit nuk do të njihet asnjë dëmtim nga transporti ose dëmtim i sipërfaqes.
- / Tubacionet dhe rubinetet duhet që të montohen, të shpëlahen dhe të kontrollohen sipas standardeve në fuqi
- / Duhet të respektohen linjat udhëzuese të instalimit, të vlefshme për vendet respektive.

TË DHËNA TEKNIKE

Presioni gjatë punës	maks. 1 MPa
Presioni i rekomanduar:	0,1 - 0,5 MPa
Presioni për provë:	1,6 MPa
	(1 MPa = 10 bar = 147 PSI)
Temperatura e ujit të ngrohtë	maks. 70°C
Temperatura e rekomanduar e ujit të ngrohtë:	65°C
Dezinfektim Termik:	maks. 70°C / 4 min
Produkti është projektuar ekskluzivisht për ujë të pijshëm!	

PËRSHKRIMI I SIMBOLIT



Mos përdorni silikon që në përbërje ka acid acetik.



JUSTIMI (shih faqen 38)

Rregullimi i kufizimit me ujë të nxehtë. Nje kombinim me një bojler ujit nuk është i rekomanduar.



PËRMASAT (shih faqen 39)



DIAGRAMI I QARKULLIMIT (shih faqen 39)

rrijdhja e lirë



PJESËT E SERVISIT (shih faqen 42)

XXX = Kodimi me anë të ngjyrave

000 = Krom

310 = Brushed Redgold

330 = Polished Black Chrome

820 = Brushed Nickel

930 = Polished Brass



PAJISJE TË POSAÇME (shih faqen 44)

nuk përfshihet në vëllimin e furnizimit

/ Zgjatësi 25 mm #13595000

/ Zgjatësi 33 mm (lartësia e montimit jo e madhe) #14972XXX, #14968XXX, #14961XXX



PASTRIMI (shih faqen 45)



PËRDORIMI (shih faqen 40)



SHENJA E KONTROLLIT (shih faqen 46)

DEMTIM	SHKAKU	NDIHME
/ Armatura punon rende	/ Kartusha me defekt, me kalk	/ Kembeni kartushen
/ Armatura pikon	/ Kartusha me defekt	/ Kembeni kartushen
/ Kalibruesi nuk funksionon	/ Dekompozimet	/ Pastroni ndërruesin e pozicionit / Vajosni unazat O
	/ Presion shumë i ulët i ujit	/ Rrisni presionin e ujit
	/ Kalibruesi me defekt	/ kembeni kalibruesin
/ Temperaturë e ulët e ujit të ngrohtë, nuk ka ujë të ftohtë. Ngrohësi elektrik i ujit ndizet kur zgjidhet uji i ftohtë.	/ Kufiri i ujit te ngrohte eshte regjistruar gabim	/ Regjistroni kufirin e ujit te ngrohte
	/ Rrjedhje e kryqëzuar.	/ Kembeni kartushen



⚠ تنبيهات الأمان

⚠ يجب إرتداء قفازات الليد أثناء التركيب لتجنب حدوث أخطار الإنحشار أو الجروح.

⚠ لا يجب استخدام المنتج إلا في أغراض الاستحمام والأغراض الصحية وأغراض تنظيف الجسم.

⚠ يجب أن يكون تيار الماء الساخن والماء البارد متعادلين في الضغط.

تعليمات التركيب

/ قبل القيام بعملية التركيب، يجب فحص المنتج للتأكد من خلوه من أية تلفيات ناتجة عن النقل. بعد القيام بعملية التركيب، لن يتم الاعتراف بوجود أية تلفيات سطحية أو تلفيات ناتجة عن عملية النقل.

/ يجب تركيب وغسيل واختبار التوصيلات وخلاطات المياه طبقاً للمعايير السارية.

/ يجب مراعاة القواعد الخاصة بالتركيب وأعمال السباكة وفقاً للوائح الخاصة بكل بلد.

المواصفات الفنية

ضغط التشغيل: الحد الأقصى 1 ميجاباسكال
ضغط التشغيل الموصى به: 0,5 - 0,1 ميجاباسكال
ضغط الاختبار: 1,6 ميجاباسكال

(1 ميجاباسكال = 10 بار = 147 PSI)
درجة حرارة الماء الساخن: الحد الأقصى 70°C
درجة الحرارة الموصى بها للماء الساخن: 65°C
تعقيم حراري: الحد الأقصى 70°C / 4 الدقيقة
المنتج مخصص فقط لماء الشرب!

وصف الرمز

هام! لا تستخدم السليكون الذي يحتوي على أحماض! 

الضبط (راجع صفحة 38)



ضبط تحديد المياه الدافئة. لا ينصح باستخدام محدد المياه الدافئة مع سخان المياه اللوكتي.

أبعاد (راجع صفحة 39)



رسم للصفحة (راجع صفحة 39)

التدفق الحر

قطع الغيار (راجع صفحة 42)

الألوان = XXX

كروم = 000

Brushed Redgold = 310

Polished Black Chrome = 330

Brushed Nickel = 820

Polished Brass = 930

ملحقات خاصة (راجع صفحة 44)

غير مدرج مع المحتويات المسلمة

/ وصلة إطالة 25 مم #13595000

/ طقم الملحقات 33 مم (عندما لا يكون الجدار

عميقاً بما يكفي) #14972XXX, #14968XXX,

#14961XXX

التنظيف (راجع صفحة 45)



التشغيل (راجع صفحة 40)



شهادة اختبار (راجع صفحة 46)



العلاج والإصلاح	السبب	العتل
قم بتغيير الخرطوشة	/ الخرطوشة تالفة، تراكم عليها الجير	/ الخلاط ثقيل الحركة
قم بتغيير الخرطوشة	/ الخرطوشة تالفة	/ تساقط قطرات مياه من الخلاط
/ تنظيف الخلاط وتشحيم الحلقة الدائرية.	/ الرواسب	/ المحول لا يعمل
/ ارفع ضغط الماء	/ ضغط الماء منخفض للغاية	/ درجة حرارة الماء الساخن منخفضة للغاية، ولا يوجد ماء بارد. سخان المياه الفوري يعمل عند استخدام الماء البارد.
/ قم بتغيير المحول	/ المحول تالف	
/ قم بضبط محدد الماء الساخن	/ محدد الماء الساخن مضبوط بشكل خاطيء	
/ قم بتغيير الخرطوشة	/ اندفاع متعاكس للمياه	

التركيب (راجع صفحة 32) 

△ BIZTONSÁGI UTASÍTÁSOK

- △ A szerelésnél a zúzódások és vágási sérülések elkerülése érdekében kesztyűt kell viselni.
- △ A terméket csak fürdéshez, mosakodáshoz, és egészségügyi tisztálkodáshoz szabad használni.
- △ A hidegvíz- és a melegvíz-csatlakozások közötti nagy nyomáskülönbséget kikell egyenlíteni!

SZERELÉSI UTASÍTÁSOK

- / A szerelés előtt ellenőrizni kell, hogy a terméknek nincs-e szállítási sérülése. Beépítés után a szállítási-vagy felületi sérüléseket nem ismerik el.
- / A vezetékeket és a csaptelepet az érvényes szabványoknak megfelelően kell felszerelni, öblíteni és ellenőrizni
- / Az egyes országokban érvényes installációs irányelveket be kell tartani.

MŰSZAKI ADATOK

Üzemi nyomás:	max. 1 MPa
Ajánlott üzemi nyomás:	0,1 - 0,5 MPa
Nyomáspróba:	1,6 MPa
	(1 MPa = 10 bar = 147 PSI)
Forróvíz hőmérséklet:	max. 70°C
Forróvíz javasolt hőmérséklete:	65°C
Termikus fertőtlenítés:	max. 70°C/4 perc

A terméket kizárólag ivóvízhez tervezték!

SZIMBÓLUMOK LEÍRÁSA



Ne használjon ecetsavtartalmú szilikon!



BEÁLLÍTÁS (lásd a oldalon 38)

A meleg víz korlátozás beállítása. Átfolyós vízmelegítőknél meleg víz korlátozó használata nem ajánlott.



MÉRETET (lásd a oldalon 39)



ÁTFOLYÁSI DIAGRAMM

(lásd a oldalon 39)

szabad átfolyás



TARTOZÉKOK (lásd a oldalon 42)

XXX = Színkódolás

000 = Króm

310 = Brushed Redgold

330 = Polished Black Chrome

820 = Brushed Nickel

930 = Polished Brass



EGYÉB TARTOZÉK

(lásd a oldalon 44)

a szállítási egység nem tartalmazza

/ Hosszabbítás 25 mm #13595000

/ Hosszabító készlet 33 mm (kis beépítési mélység esetén) #14972XXX, #14968XXX, #14961XXX



TISZTÍTÁS (lásd a oldalon 45)



HASZNÁLAT (lásd a oldalon 40)

- / A csaptelepeken átfolyó víz hőmérséklete fogyasztásra szánt víz esetében a 65°C-ot nem haladhatja meg. A csaptelep nem eredményezheti az emberi fogyasztásra (pl. ivás és főzés céljából) szánt víz minőségromlását.
- / Beüzemelés és üzemszünetek után szigorúan be kell tartani a használati útmutatóban leírtakat. Beüzemeléskor a csaptelepet át kell öblíteni, legalább 2 percig történő hideg- és melegvízes folyatást javasolunk. Minimum 1 napos üzemszünet után fogyasztás előtt a csaptelepben stagnáló hideg- illetve melegvíz fogyasztása nem javasolt, a csaptelepben stagnáló vizet ki kell engedni, legalább 2 perces folyatás javasolt. A kifolyatás során nyert vizet ivóvízként, illetve ételkészítési céllal felhasználni nem szabad.
- / Tekintettel arra, hogy a forró víz fémoldó képessége a hideg víznél nagyobb, emiatt főzés ivás céljából az OKI a hideg víz használatát javasolja.
- / A csaptelepek perlátorát javasolt havonta vízköteníteni, illetve fertőtleníteni. A csaptelepek tisztítása, fertőtlenítése során kizárólag olyan vegyszer alkalmazható, amely megfelel a 201/2001. (X.25) Kormányrendelet, illetve a 38/2003. (VII.7) ÉSzCsM-FVM-KvVM együttes rendeletben leírtaknak.

- / A perlátor működési elvéből adódóan jelentős aeroszolt képez, így Legionella expozíció szempontjából fokozott kockázatot jelent. Ezért alkalmazása nem javasolt az egészségügyi intézmények fekvőbeteg ellátó szobáiban, illetve minden olyan helyen, ahol a hideg és/vagy használati melegvíz Legionella csíraszám eléri a 49/2015 (XI.ó.) EMMI rendelet alapján meghatározott beavatkozási szintet.



V I Z S G A J E L (lásd a oldalon 46)

HIBA	OK	MEGOLDÁS
/ Nehezen nyitható a csap.	/ A kerámiabetét meghibásodott, elvizesedett.	/ A kerámiabetétet ki kell cserélni.
/ Csöpög a csap.	/ A kerámiabetét meghibásodott.	/ A kerámiabetétet ki kell cserélni.
/ Az átállítás nem működik	/ Lerakódások	/ Váltószelepet tisztítani/O-gyűrűket zsírozni
	/ Túl kicsi víznyomás	/ Növelje a víznyomást
	/ A kádváltó szelep hibás	/ Az átállító cseréje
/ Túl alacsony melegvíz hőmérséklet, nincs hidegvíz. A hidegvíz kiválasztásakor beindul az átfolyós melegítő.	/ A melegvíz szabályozó rosszul van beállítva.	/ A melegvíz szabályozót újra be kell állítani.
	/ Kereszfolyás	/ A kerámiabetétet ki kell cserélni.





AXOR Urquiola/AXOR Starck Organic/AXOR Massaud

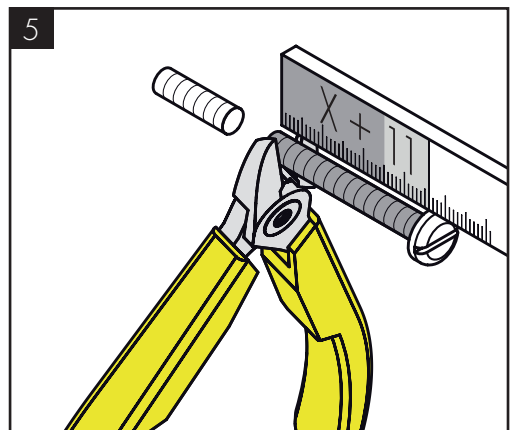
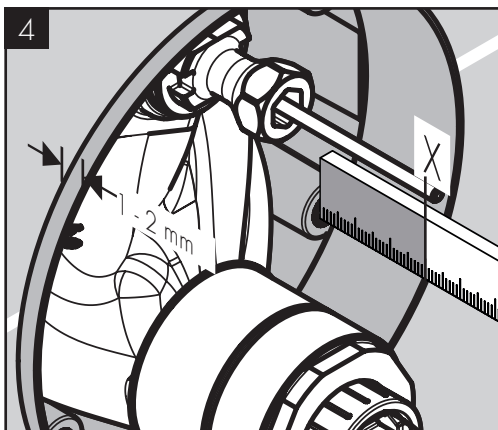
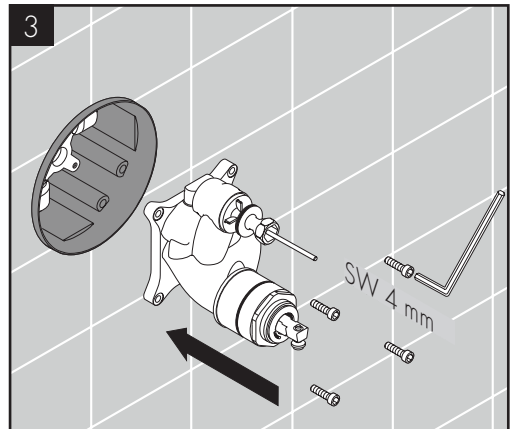
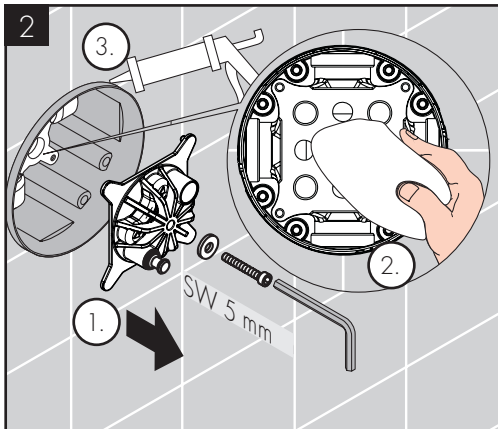
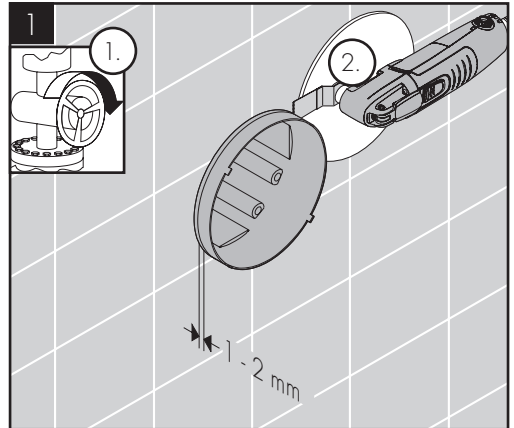
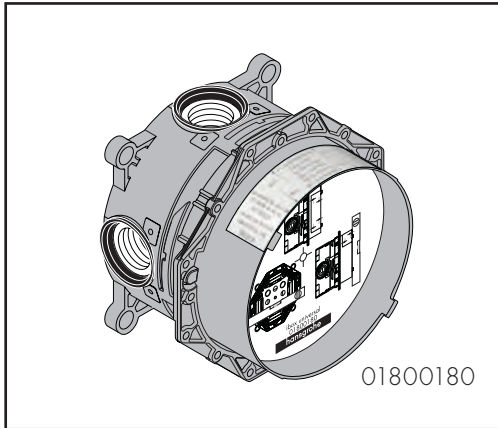



AXOR Urquiola/AXOR Starck Organic/AXOR Massaud

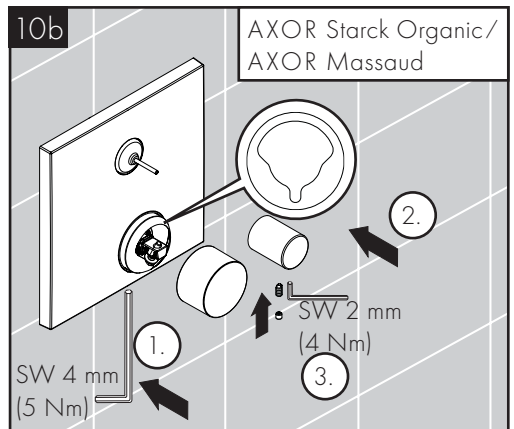
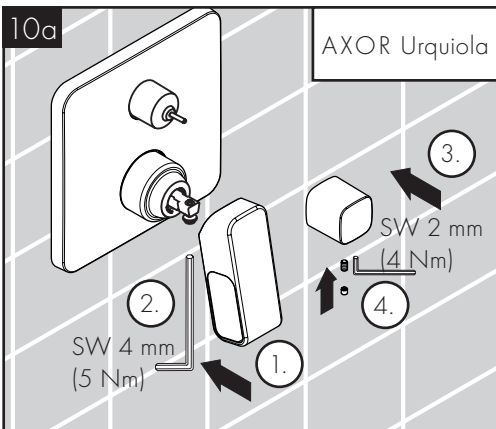
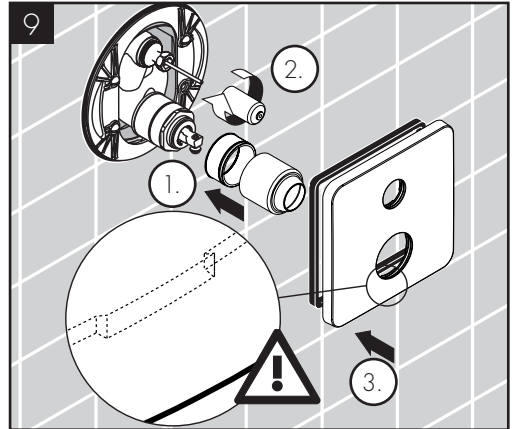
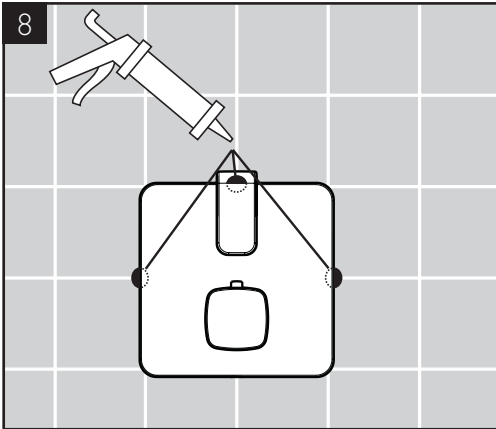
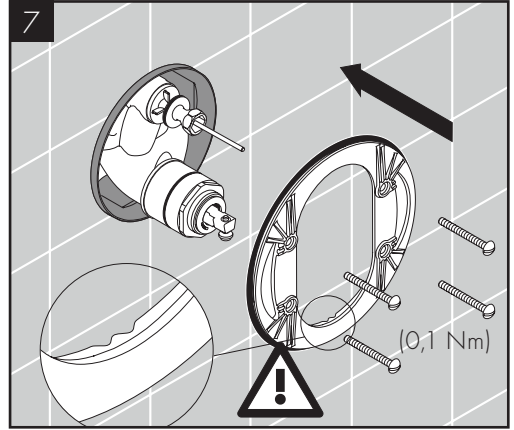
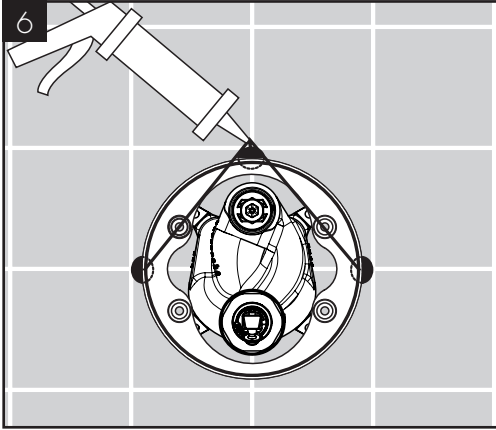



AXOR Uno

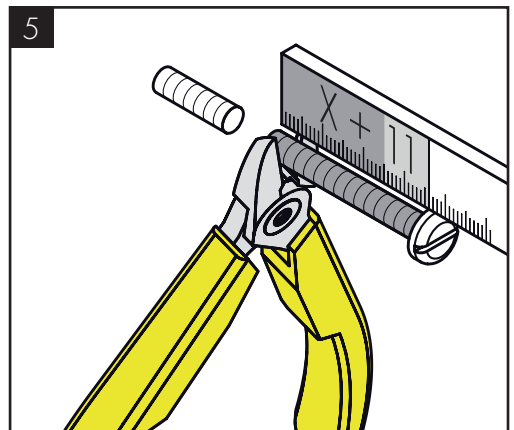
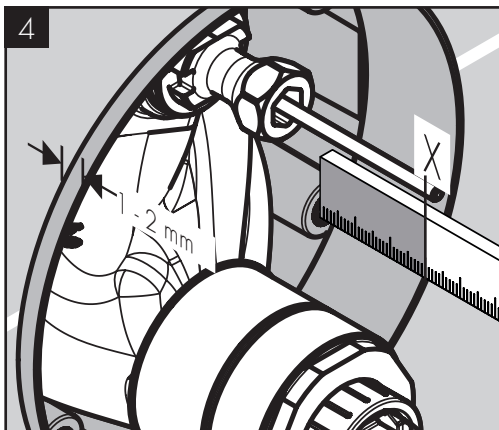
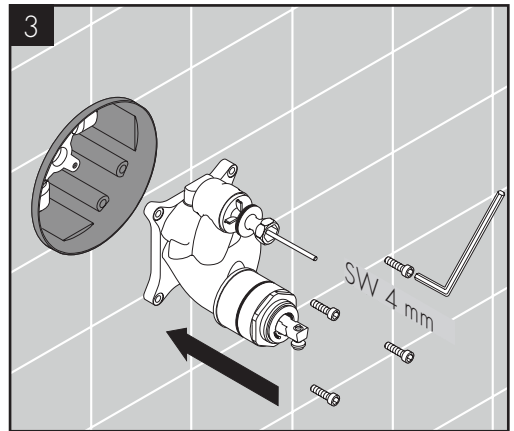
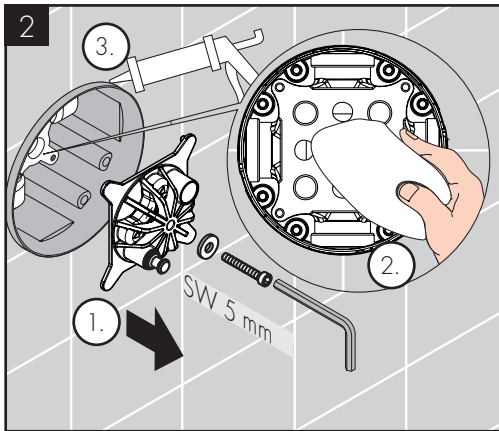
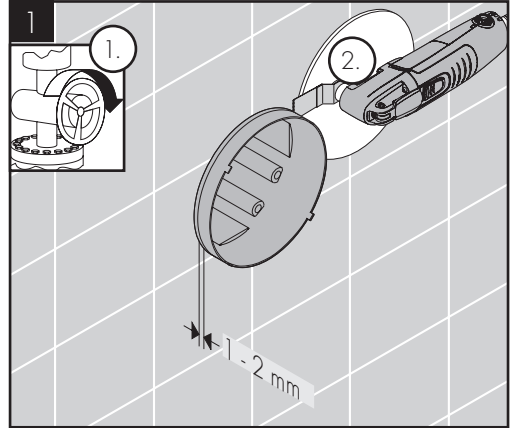
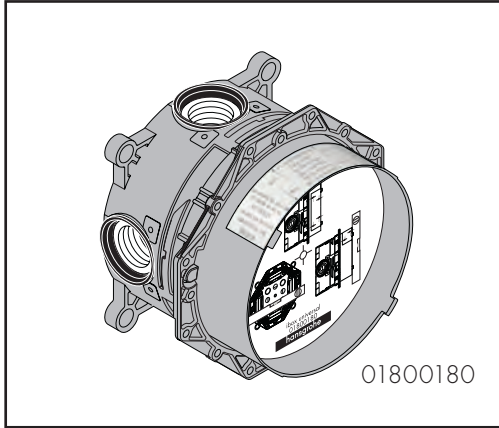



AXOR Uno

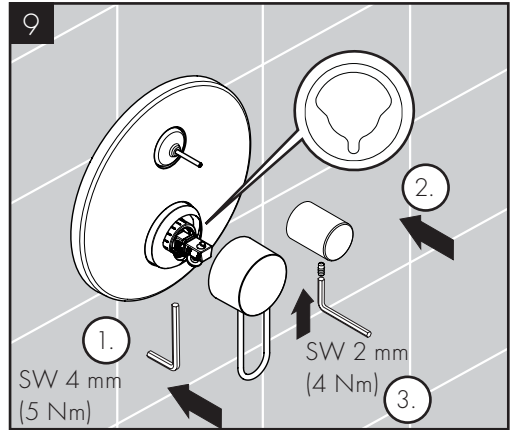
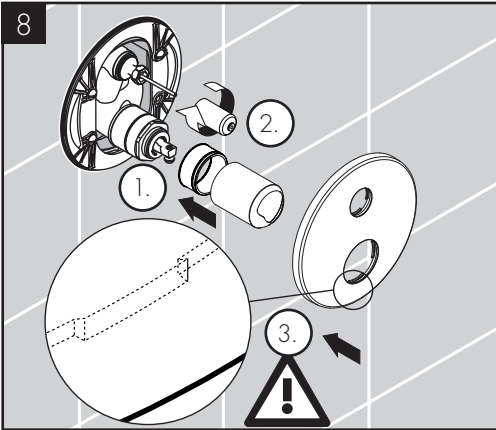
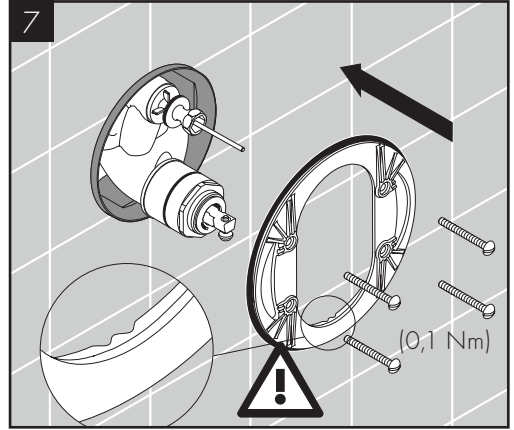
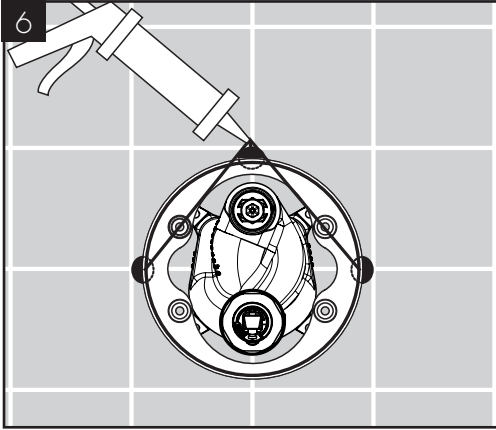



AXOR Edge

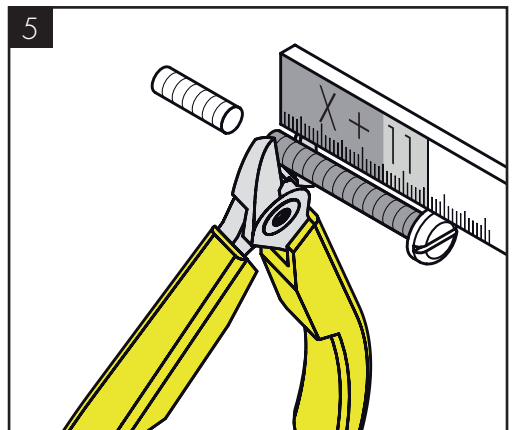
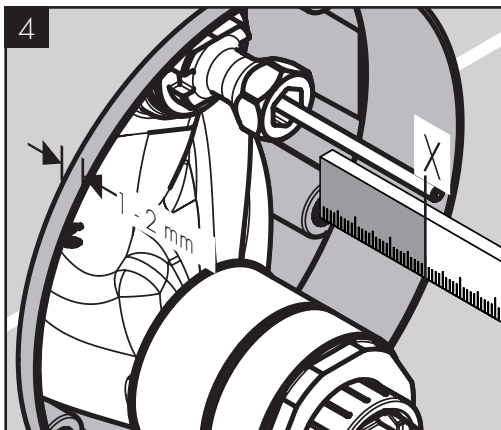
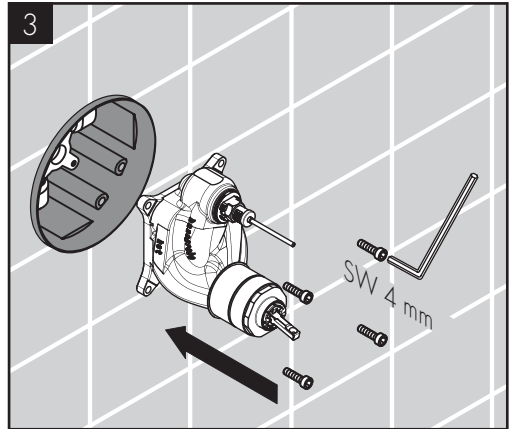
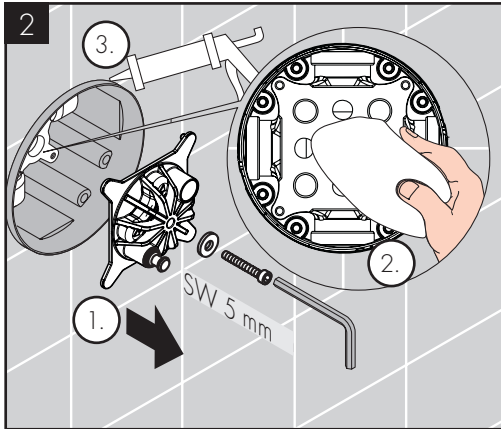
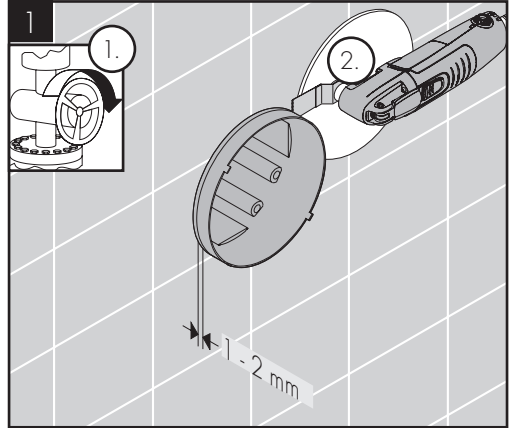
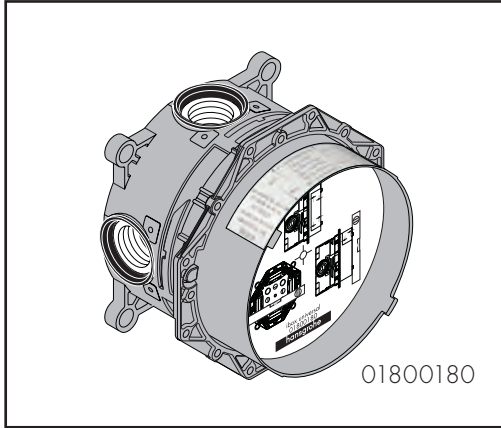



AXOR Edge

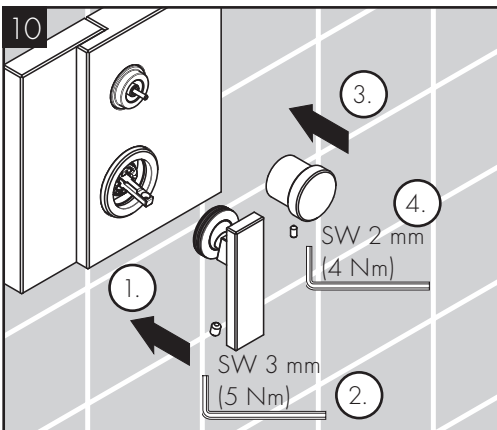
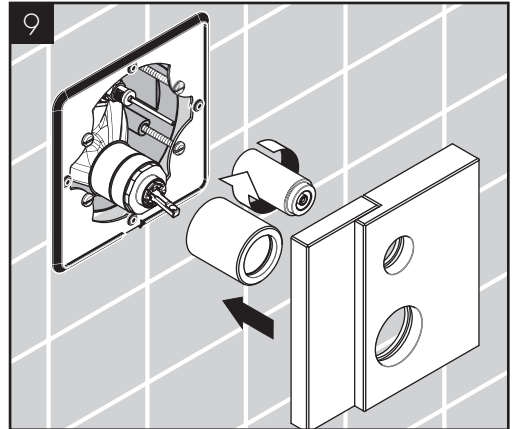
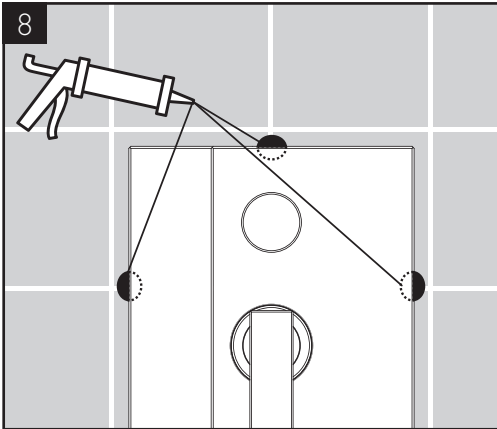
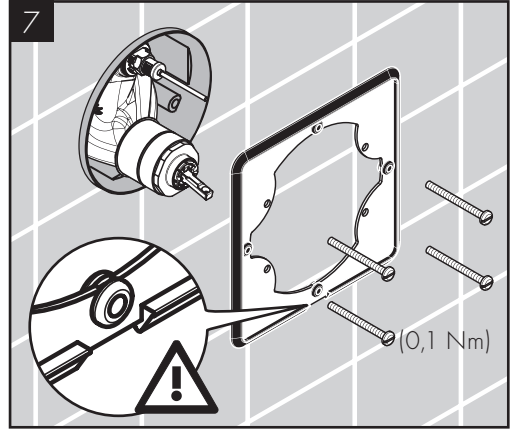
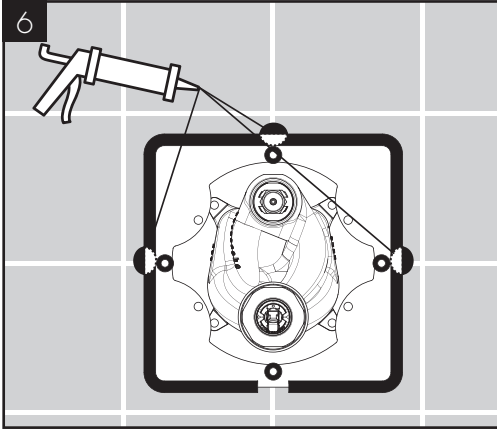

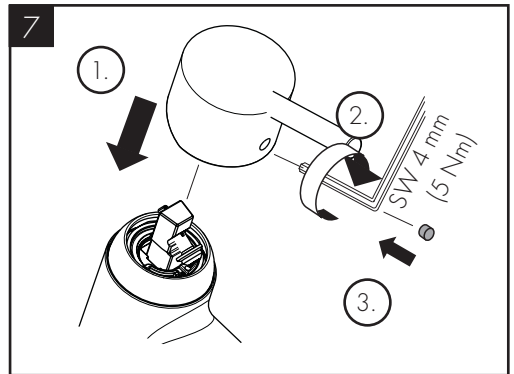
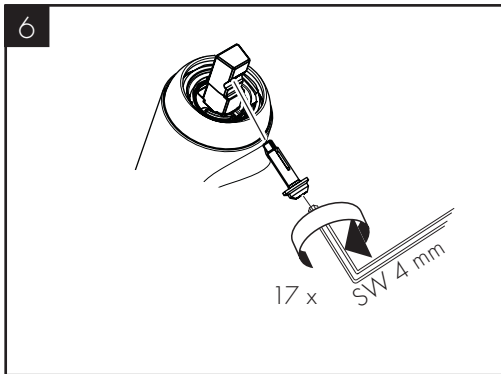
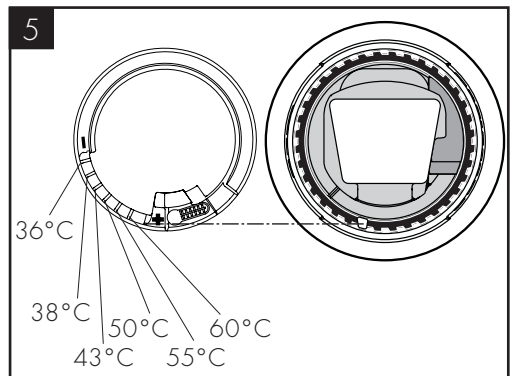
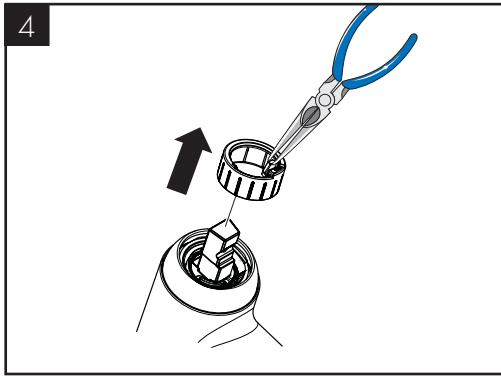
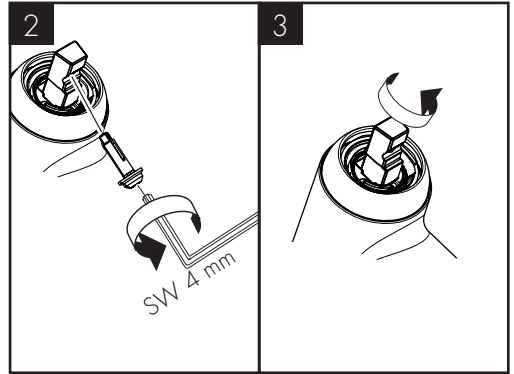
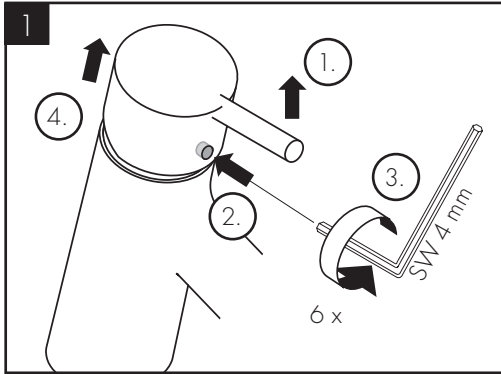



AXOR Urquiola
11425000

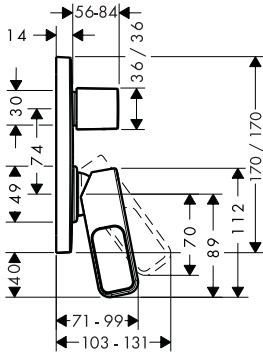

AXOR Starck Organic
12415000

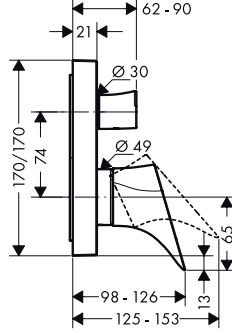

AXOR Massaud
18455000

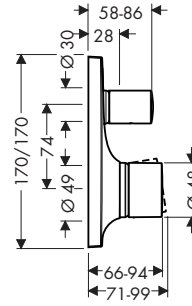

AXOR Uno
38426XXX

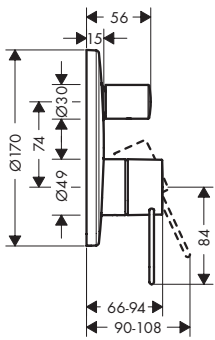

AXOR Uno
45405XXX

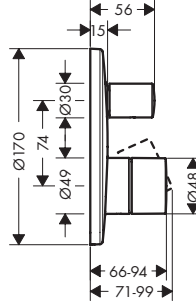

AXOR Edge
46450000/46451000

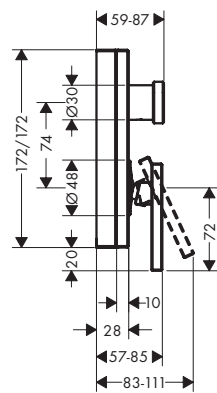

AXOR Urquiola 11425000

AXOR Massaud 18455000

AXOR Starck Organic 12415000

AXOR Uno 38426XXX/45405XXX

AXOR Edge 46450000/46451000

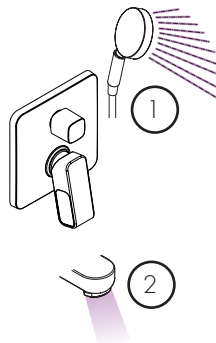
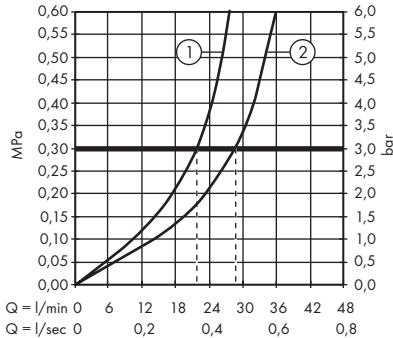

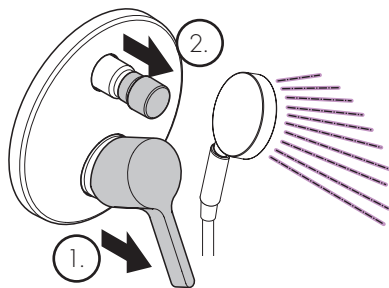
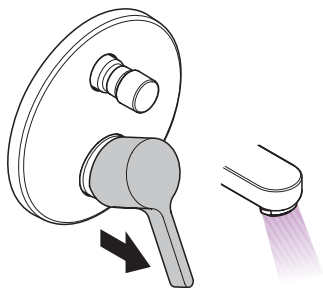

öffnen / ouvert / open / aperto / abierto / open / åbne / abrir / otworzyć / otevřít / otvorit / 开 / открыт / nyitás / avaaminen / öppna / atidaryti / Otvaranje / açmak / deschide / ανοικτό / odpreti / avage / atvērti / otvoriti / åpne / отварање / hape / فتح

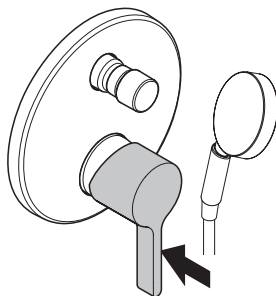
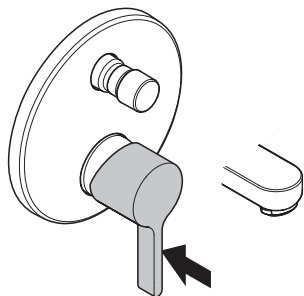

schließen / fermé / close / chiudere / cerrar / sluiten / lukke / fechar / zamknąć / zavřít / uzavriť / 关 / закрыть / bezárás / sulkeminen / stänga / uždaryti / Zatvaranje / kapatmak / închide / κλειστό / zapreti / sulgege / aizvērt / zatvori / lukke / zatvaranje / mbylle / إغلاق

11425000 / 18455000 / 19421000 / 38426XXX / 45405XXX / 46450000 / 46451000

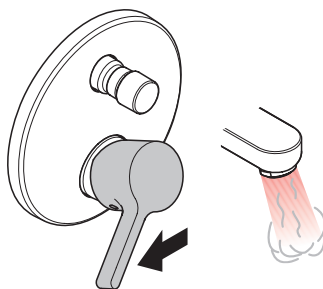

kalt / froid / cold / freddo / frío / koud / koldt / fría / zimna / studená / studená / 冷 / холодная / hideg / kylmä / kallt / šaltas / Hladno / soğuk / rece / κρύο / mrzlo / külm / auksts / hladno / koldt / студено / ifohtie / بارد

warm / chaud / hot / caldo / caliente / warm / varmt / quente / ciepła / teplá / teplá / 热 / горячая / meleg / lämmin / varmt / karštas / Vruća voda / sıcak / cald / ζεστό / toplo / kuum / karsts / topla / varm / toplo / i ngrohtë / ساخن



12415000

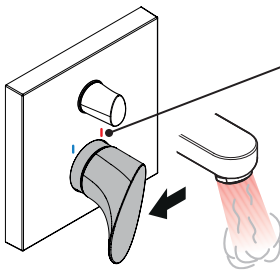

rot/rouge/red/
 rosso/rojo/rood/
 Rød/vermelho/
 czerwony/červená/
 červená/
 红色/красный/
 piros/punainen/röd/
 raudona/crvena/
 kırmızı/roşu/kókkivo/
 rdeča/punane/
 sarkana/crvena/rød/
 червено/e kuqe/
 أحمر

blau/bleu/blue/
 blu/azul/blauw/
 Blå/azul/
 niebieski/modrá/
 modrá/藍色/
 синий/kék/
 sininen/blå/
 mēlyna/plava/
 mavi/albastru/
 μπλε/modra/
 sinine/zila/plava/
 blå/синьо/blu/
 أزرق

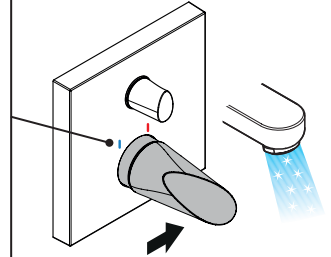

warm/chaud/hot/caldo/caliente/warm/varmt/quente/
 ciepła/teplá/teplá/热/горячая/meleg/lämmin/varmt/
 karštas/Vruća voda/sıcak/cald/ζεστό/toplo/kuum/
 karsts/topla/varm/топло/i ngrohtë/ساخن

kalt/froid/cold/freddo/frío/koud/koldt/fria/zimna/
 studená/studená/冷/холодная/hideg/kylmä/kallt/
 šaltas/Hladno/soğuk/rece/κρύο/mrzlo/külm/auksts/
 hladno/kaldt/студено/i ftohtë/بارد



AXOR Urquiola
11425000

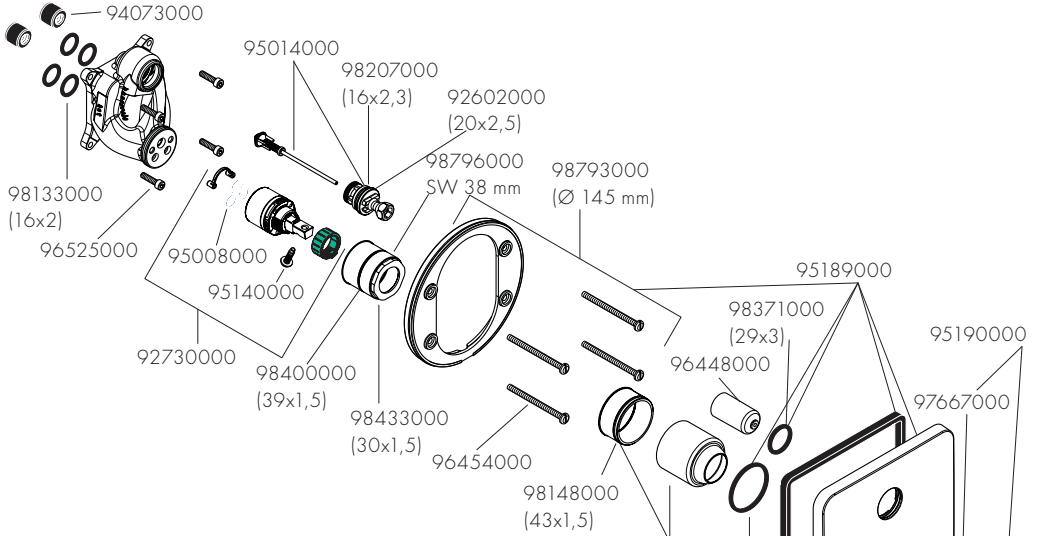

AXOR Massaud
18455000

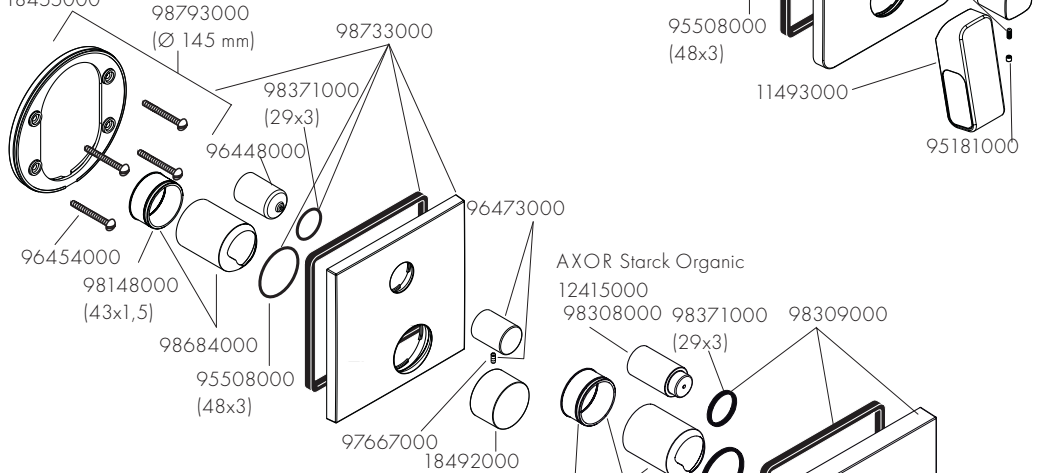

AXOR Starck Organic
12415000

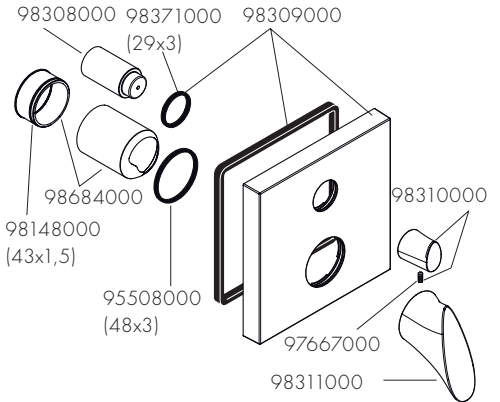



AXOR Uno

38426XXX/345405XXX

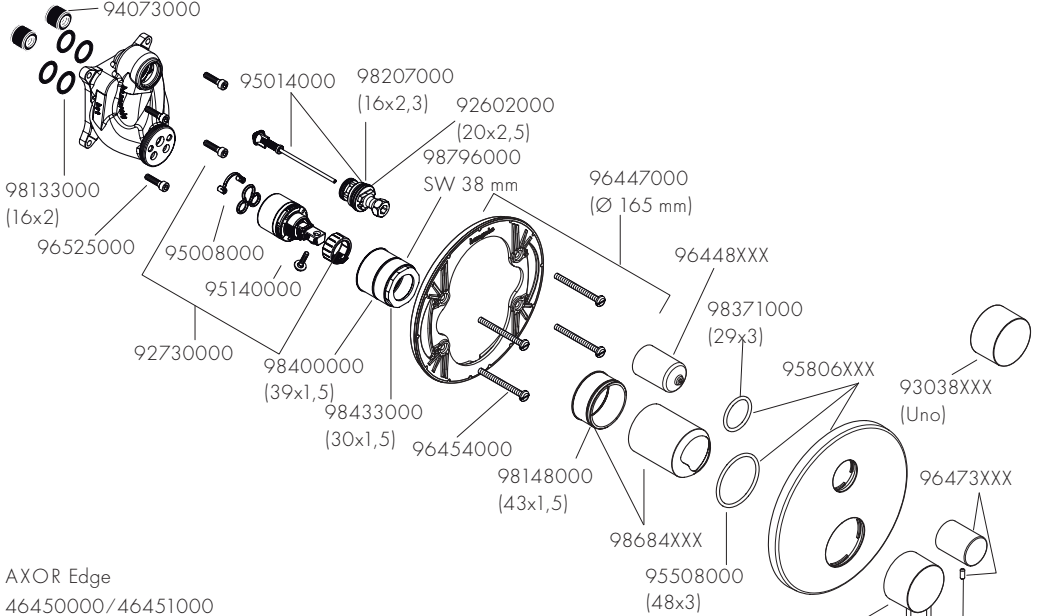

AXOR Edge

46450000/46451000

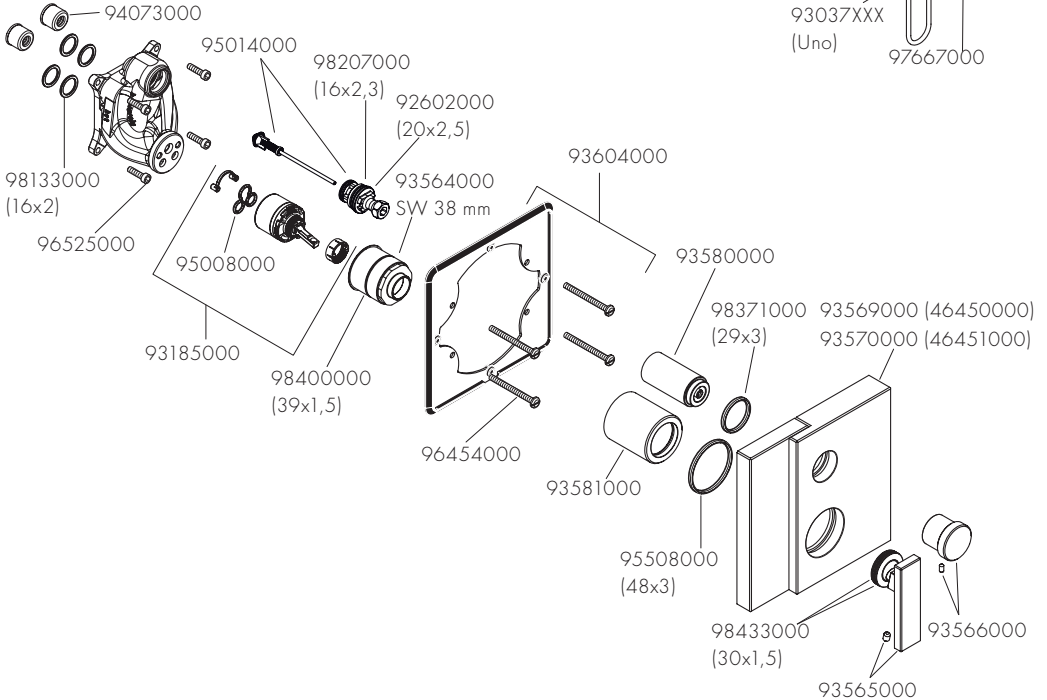

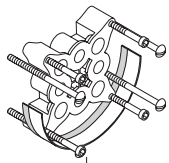
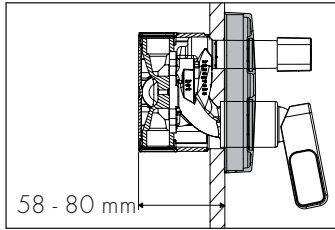
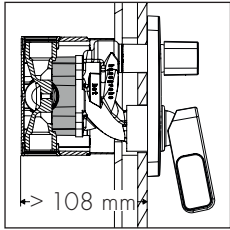

13595000
25 mm

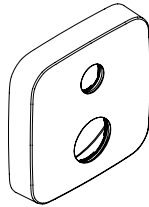

14972000
AXOR Urquiola/
AXOR Bouroullec
(33 mm)

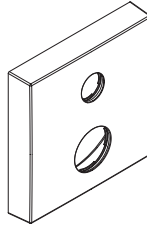

14968000
AXOR Starck Organic/
AXOR Massaud
(33 mm)

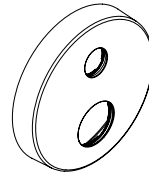

14961XXX
AXOR Uno
(33 mm)



- DE / Reinigungsempfehlung / Garantie / Kontakt
 FR / Recommandation pour le nettoyage / Garanties / Contact
 EN / Cleaning recommendation / Warranty / Contact
 IT / Raccomandazione di pulizia / Garanzia / Contatto
 ES / Recomendaciones para la limpieza / Garantía / Contacto
 NL / Aanbevelingen inzake reiniging / Garantie / Contact
 DK / Rensning, anbefaling / Garanti / Kontakt
 PT / Recomendações de limpeza / Garantia / Contacto
 PL / Zalecenie dotyczące pielęgnacji / Gwarancja / Kontakt
 CS / Doporučení k čištění / Záruka / Kontakt
 SK / Odporúčania pre čistenie / Záruka / Kontakt
 ZH / 清洁指南 / 担保 / 接触
 RU / Рекомендации по очистке / Гарантия / Контакты
 HU / Tisztítási tanácsok / Garancia / érintkezés
 FI / Puhdistussuositus / Takuu / Kosketus
 SV / Rengöringsrekommendationer / Garanti / Contacto
 LT / Valymo rekomendacijos / Garantija / Kontaktai
 HR / Preporuke za čišćenje / Garancija / Kontakt
 TR / Temizleme önerisi / Garanti / Temas
 RO / Recomandări pentru curățare / Garanție / Contact
 EL / Σύσταση καθαρισμού / Εγγύηση / επαφή
 SL / Priporočilo za čišćenje / Garancija / Kontakt
 ET / Puhastussuovitused / Garantii / Kontakt
 LV / Tīrīšanas ieteikumi / Garantija / Kontakti
 SR / Preporuke za čišćenje / Garancija / Kontakt
 NO / Anbefaling for rengjøring / Garanti / Kontakt
 BG / Препоръка за почистване / Гаранция / Контакт
 SQ / Këshilla rreth pastrimit / Garancia / Kontakt
 KO / 세정시 권장사항 / 품질보증 / 접촉
 AR / توصيات التنظيف / الضمان (الولايات المتحدة الأمريكية) / اتصال



[www.axor-design.com/
cleaning-recommendation](http://www.axor-design.com/cleaning-recommendation)

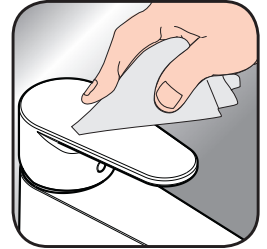

[www.axor-design.com/
cleaning-recommendation](http://www.axor-design.com/cleaning-recommendation)







[www.axor-design.com/
cleaning-recommendation](http://www.axor-design.com/cleaning-recommendation)



[www.axor-design.com/
cleaning-recommendation](http://www.axor-design.com/cleaning-recommendation)



	P-IX	DVGW		ETA
11425000	PA-IX 9709/ICC	CQ0125	1392	 1.42/18751
12415000	PA-IX 9709/ICC	CQ0125	1392	 1.42/18751
18455000	PA-IX 9709/ICC	CQ0125	1392	 1.42/18751
19421000	PA-IX 9709/ICC	CQ0125		 1.42/18751
38426000	PA-IX 9709/ICC		1392	
45405000	PA-IX 9709/ICC		1392	
46450000				
46451000				

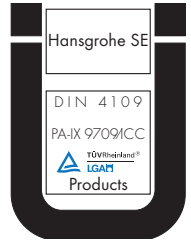

AXOR

AXOR / Hansgrohe SE
Austraße 5-9
77761 Schiltach
Deutschland

info@axor-design.com
axor-design.com

03/2019
9.04931.11