

DE /	Gebrauchsanleitung / Montageanleitung	02
FR /	Mode d'emploi / Instructions de montage	03
EN /	Instructions for use / assembly instructions	04
IT /	Istruzioni per l'uso / Istruzioni per Installazione	05
ES /	Modo de empleo / Instrucciones de montaje	06
NL /	Gebruiksaanwijzing / Handleiding	07
DK /	Brugsanvisning / Monteringsvejledning	08
PT /	Instruções para uso / Manual de Instalação	09
PL /	Instrukcja obsługi / Instrukcja montażu	10
CS /	Návod k použití / Montážní návod	11
SK /	Návod na použitie / Montážny návod	12
ZH /	用户手册 / 组装说明	13
RU /	Руководство пользователя / Инструкция по монтажу	14
FI /	Käyttöohje / Asennusohje	15
SV /	Bruksanvisning / Monteringsanvisning	16
LT /	Vartotojo instrukcija / Montavimo instrukcija	17
HR /	Upute za uporabu / Uputstva za instalaciju	18
TR /	Kullanım kılavuzu / Montaj kılavuzu	19
RO /	Manual de utilizare / Instrucțiuni de montare	20
EL /	Οδηγίες χρήσης / Οδηγία συναρμολόγησης	21
SL /	Navodilo za uporabo / Navodila za montažo	22
ET /	Kasutusjuhend / Paigaldusjuhend	23
LV /	Lietošanas pamācība / Montāžas instrukcija	24
SR /	Uputstvo za upotrebu / Uputstvo za montažu	25
NO /	Bruksanvisning / Montasjeveiledning	26
BG /	Инструкция за употреба / Ръководство за монтаж	27
SQ /	Udhëzuesi i përdorimit / Udhëzime rreth montimit	28
AR /	دليل الاستخدام / تعليمات التجميع	29
HU /	Használati útmutató / Szerelési útmutató	30
JP /	取扱説明書 / 施工説明書	31

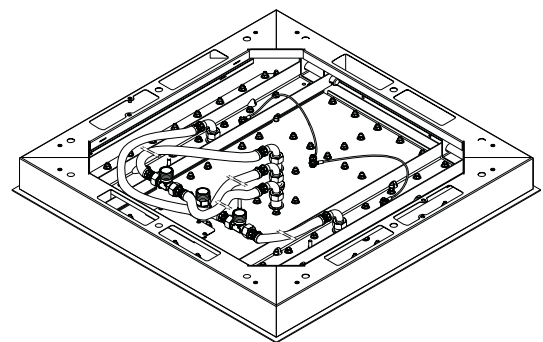

AXOR ShowerHeaven 970 3jet  
10621800 / 10623800

AXOR ShowerHeaven 720 3jet  
10625800 / 10627800

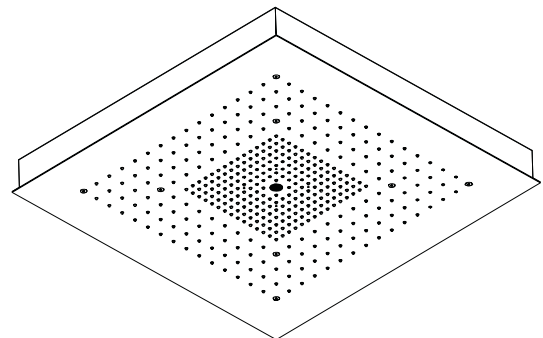

**Ihr Online-Fachhändler für:**

**hansgrohe**

- Kostenlose und individuelle Beratung
- Hochwertige Produkte
- Kostenloser und schneller Versand

- TOP Bewertungen
- Exzelerter Kundenservice
- Über 20 Jahre Erfahrung



**E-Mail: [info@unidomo.de](mailto:info@unidomo.de) | Tel.: 04621 - 30 60 89 0 | [www.unidomo.de](http://www.unidomo.de)**

## ⚠ SICHERHEITSHINWEISE

- ⚠ Bei der Montage müssen zur Vermeidung von Quetsch- und Schnittverletzungen Handschuhe getragen werden.
- ⚠ Das Produkt darf nur zu Bade-, Hygiene- und Körperreinigungszwecken eingesetzt werden.
- ⚠ Kinder, sowie Erwachsene mit körperlichen, geistigen und/oder sensorischen Einschränkungen dürfen das Produkt nicht unbeaufsichtigt benutzen. Personen, die unter Alkohol- oder Drogeneinfluss stehen, dürfen das Produkt nicht benutzen.
- ⚠ Der Kontakt der Brausestrahlen mit empfindlichen Körperstellen (z. B. Augen) muss vermieden werden. Es muss ein ausreichender Abstand zwischen Brause und Körper eingehalten werden.
- ⚠ Große Druckunterschiede zwischen den Kalt- und Warmwasseranschlüssen müssen ausgeglichen werden.

## ELEKTROANSCHLUSS

- ⚠ Der Elektroanschluss darf nur vom Elektrofachmann durchgeführt werden!
- ⚠ Spannungsversorgung 100-240V/N/PE/50-60Hz (Länge: 1 m) vorinstallieren.
- ⚠ Die Absicherung muss über eine Fehlerstrom-Schutzeinrichtung (RCD/FI) mit einem Bemessungsdifferenzstrom  $\leq 30$  mA erfolgen.
- ⚠ Das Produkt muss an einen bauseits vorhandenen Potentialausgleich (PA) 4 mm<sup>2</sup> angeschlossen werden.

## ELEKTROINSTALLATEUR

- ⚠ Die Installations- und Prüfungsarbeiten sind von einer zugelassenen Elektrofachkraft, unter Berücksichtigung von VDE 0100 Teil 701, IEC 60364-6 u. IEC 60364-7-701 sowie EN 60335-2-105, auszuführen.
- ⚠ Die Netzanschlussleitung muss doppelt isoliert  in die Anschlussdose eingeführt werden.

## MONTAGEHINWEISE

- / Vor der Montage muss das Produkt auf Transportschäden untersucht werden. Nach dem Einbau werden keine Transport- oder Oberflächenschäden anerkannt.
- / Die Leitungen und die Armatur müssen nach den gültigen Normen montiert, gespült und geprüft werden.
- / Die in den Ländern jeweils gültigen Installationsrichtlinien sind einzuhalten.
- / Bei der Montage des Produktes durch qualifiziertes Fachpersonal ist darauf zu achten, dass die Befestigungsfläche im gesamten Bereich der Befestigung plan ist (keine vorstehenden Fugen oder Fliesenversatz), der Wandaufbau für eine Montage des Produktes geeignet ist und keine Schwachstellen aufweist.
- / Beim Bohren auf Strom- und Wasserleitungen achten!
- / Die Ablaufleistung muss ausreichend dimensioniert werden.
- / Die Brause darf nur nach einem Absperrventil oder einer Sanitärarmatur angeschlossen werden.

## TECHNISCHE DATEN

Betriebsdruck vor der Armatur:	max. 0,6 MPa
Empfohlener Betriebsdruck:	0,25 - 0,5 MPa
	(1 MPa = 10 bar = 147 PSI)
Heißwassertemperatur:	max. 60°C
Empfohlene Heißwassertemperatur:	42°C
Sicherheitssperre:	40°C
<b>Warnhinweis: Eine Überschreitung dieser Temperatur kann zu Verbrennungen führen!</b>	
Thermische Desinfektion:	max. 70°C/4 min
Nennspannung:	100-240V AC 50-60Hz
Nennaufnahme:	18 W
Leuchten 4 x LED:	12V DC SELV 4 W
Das Leuchtmittel ist nicht dimmbar.	
Schutzklasse:	II
Schutzart:	IPX5
ShowerHeaven 970	
Gewicht (mit Verpackung)	47,9 kg
ShowerHeaven 720	
Gewicht (ohne Verpackung)	28,36 kg

Das Produkt ist ausschließlich für Trinkwasser konzipiert!

## SYMBOLERKLÄRUNG

-  Kein essigsäurehaltiges Silikon verwenden!
-  MASSE (siehe Seite 46)
-  DURCHFLUSSDIAGRAMM (siehe Seite 45)
-  MONTAGEBEISPIELE (siehe Seite 35)
-  SERVICETEILE (siehe Seite 48)
-  REINIGUNG (siehe Seite 54)
-  WARTUNG (siehe Seite 50)
-  Siebe austauschen (siehe Seite 50)
-  Leuchtmittel austauschen (siehe Seite 53)
-  Elektroinstallateur
-  Wasseranschluss DN20 (Warmwasser)
-  Wasseranschluss DN20 (Kaltwasser)
-  Die Ablaufleistung muss mehr als 50 l/min betragen.
-  Ablauf
-  Wasser öffnen
-  Wasser abstellen
-  Zwei Arbeitskräfte notwendig
-  Warnung vor heißer Oberfläche!
-  Schutzhandschuhe tragen
-  Augenschutz tragen
-  Naturschwamm
-  Entkalker (zitronensäurebasis)
-  Augen- und Hautkontakt vermeiden. Falls das Produkt in die Augen gelangt, diese gründlich mit Wasser ausspülen.
-  Strom an / aus

## ⚠ CONSIGNES DE SÉCURITÉ

- ⚠ Lors du montage, porter des gants de protection pour éviter toute blessure par écrasement ou coupure.
- ⚠ Le produit ne doit servir qu'à se laver et à assurer l'hygiène corporelle.
- ⚠ Il est interdit aux enfants ainsi qu'aux adultes ayant des insuffisances physiques, psychiques et/ou motoriques d'utiliser la douche sans surveillance. De même, il est interdit à des personnes sous influence d'alcool ou de drogues d'utiliser la douche.
- ⚠ Éviter le contact du jet de la douchette avec les parties sensibles du corps (telles par ex. que les yeux). Veiller à respecter un écart suffisant entre la douchette et le corps
- ⚠ Il est conseillé d'équilibrer les pressions de l'eau chaude et froide.

## RACCORD ÉLECTRIQUE

- ⚠ Seul un spécialiste est autorisé à réaliser le câblage!
- ⚠ Pré-installer l'alimentation en tension de 100-240V/N/PE/50-60Hz (longueur : 1 m).
- ⚠ La protection par fusibles doit se faire avec un dispositif de protection par courant de défaut (RCD/FI) avec un courant différentiel résiduel de maximum 30 mA.
- ⚠ Le produit doit être raccordé à une liaison équipotentielle du propriétaire (PA) 4 mm<sup>2</sup>.

## ÉLECTRICIEN INSTALLATEUR

- ⚠ Les travaux d'installation et de contrôle doivent être confiés à un électricien agréé, en respectant VDE 0100 partie 701, IEC 60364-6 et IEC 60364-7-701 ainsi que EN 60335-2-105.
- ⚠ Le câble secteur doit être introduit dans la prise de raccord, avec une double isolation .

## INSTRUCTIONS POUR LE MONTAGE

- / Avant son montage, s'assurer que le produit n'a subi aucun dommage pendant le transport. Après le montage, tout dommage de transport ou de surface ne pourra pas être reconnu.
- / Les conduites et la robinetterie doivent être montés, rincés et contrôlés selon les normes en vigueur.
- / Les directives d'installation en vigueur dans le pays concerné doivent être respectées.
- / Lors du montage de ce produit par du personnel qualifié, veiller à ce que la surface de fixation soit bien plane dans toute la zone de fixation (pas de dépassement de joints ou de déport de carreaux), à ce que le mur se prête au montage du produit et ne présente aucun point fragile.
- / Lors de travaux de perçage sur des conduites électriques et des conduites d'eau!
- / Le débit du vidage doit être suffisamment dimensionné.
- / La douchette ne doit être raccordée qu'en aval d'une vanne d'arrêt ou d'une robinetterie sanitaire.

## INFORMATIONS TECHNIQUES

Pression de service devant la robinetterie:	max. 0,6 MPa
Pression de service conseillée:	0,25 - 0,5 MPa (1 MPa = 10 bar = 147 PSI)
Température d'eau chaude:	max. 60°C
Température recommandée:	42°C
Blocage de sécurité:	40°C

























Avertissement: tout dépassement de cette température peut entraîner des brûlures

Désinfection thermique:	max. 70°C / 4 min
Tension nominale:	100-240V AC 50-60Hz
Consommation nominale:	18 W
Lampes 4 x LED:	12V DC SELV 4 W
Source lumineuse dont la luminosité ne peut pas être atténuée.	
Classe de protection:	II
Mode de protection:	IPX5

ShowerHeaven 970	
Poids (avec emballage)	47,9 kg
ShowerHeaven 720	
Poids (sans emballage)	28,36 kg

Le produit est exclusivement conçu pour de l'eau potable!

## DESCRIPTION DU SYMBOLE

-  Ne pas utiliser de silicone contenant de l'acide acétique!
-  DIMENSIONS (voir pages 46)
-  DIAGRAMME DU DÉBIT (voir pages 45)
-  EXEMPLES DE MONTAGE (voir pages 35)
-  PIÈCES DÉTACHÉES (voir pages 48)
-  NETTOYAGE (voir pages 54)
-  ENTRETIEN (voir pages 50)
-  Remplacer les tamis (voir pages 50)
-  Remplacer l'élément lumineux (voir pages 53)
-  Électricien installateur
-  Raccord d'eau DN20 (Eau chaude)
-  Raccord d'eau DN20 (Eau froide)
-  Le débit de vidage doit être supérieur à 50 l/min.
-  Vidage
-  Ouvrir l'eau.
-  Couper l'arrivée d'eau
-  Présence de deux personnes nécessaire
-  Attention à la température élevée à la surface !
-  Protection obligatoire des mains
-  Protection obligatoire de la vue
-  éponge naturelle
-  Détartrant (À base d'acide citrique)
-  Éviter tout contact avec les yeux et la peau. Si le produit saute aux yeux, rincer ces derniers à l'eau abondante
-  Courant marche / arrêt

### ⚠ SAFETY NOTES

- ⚠ Gloves should be worn during installation to prevent crushing and cutting injuries.
- ⚠ The product may only be used for bathing, hygienic and body cleaning purposes.
- ⚠ Children as well as adults with physical, mental and/or sensoric impairments must not use this product without proper supervision. Persons under the influence of alcohol or drugs are prohibited from using this product.
- ⚠ Do not allow the streams of the shower touch sensitive body parts (such as your eyes). An adequate distance must be kept between the shower and you.
- ⚠ The hot and cold supplies must be of equal pressures.

### ELECTRICAL CONNECTION

- ⚠ The electrical connection may only be carried out by an electrician!
- ⚠ Pre-install voltage supply 100-240V/N/PE/50-60Hz (length: 1).
- ⚠ The system must be protected via a leakage current protective device (RCD/FI) with a measurement difference current of  $\leq 30$  mA.
- ⚠ The product must be connected to 4 mm<sup>2</sup> equipotential bonding (PA) to be provided by the customer.

### ELECTRICIAN

- ⚠ The installation and testing work must be performed by a skilled electrician in observance of VDE 0100 part 701, IEC 60364-6 and IEC 60364-7-701 as well as EN 60335-2-105.
- ⚠ The mains connection line must be inserted into the connection socket with double insulation .

### INSTALLATION INSTRUCTIONS

- / Prior to installation, inspect the product for transport damages. After it has been installed, no transport or surface damage will be honoured.
- / The pipes and the fixture must be installed, flushed and tested as per the applicable standards.
- / The plumbing codes applicable in the respective countries must be observed.
- / During installation of the product by qualified trained personnel, make sure that the entire fastening surface is even and smooth (no protruding seams or tile offset), that the finish of the wall is suitable to apply the product and has no weak points.
- / Observe all current and water lines when drilling!
- / The performance of the waste must be of sufficient size.
- / The shower may only be connected downstream of a shut-off valve or sanitary fitting.

### TECHNICAL DATA

Operating pressure in front of the shower fitting:	max. 0,6 MPa
Recommended operating pressure:	0,25 - 0,5 MPa
	(1 MPa = 10 bar = 147 PSI)
Hot water temperature:	max. 60°C
Recommended hot water temp.:	42°C
safety lock:	40°C























Warning: Exceeding this temperature can cause burns!	
Thermal disinfection:	max. 70°C/4 min
Nominal voltage:	100-240V AC 50-60Hz
Nominal consumption:	18 W
Lights 4 x LED:	12V DC SELV 4 W
The lamp cannot be dimmed.	
Protection class:	II
Protection category:	IPX5

ShowerHeaven 970  
Weight (with packaging) 47,9 kg

ShowerHeaven 720  
Weight (without packaging) 28,36 kg

The product is exclusively designed for drinking water!

### SYMBOL DESCRIPTION

	Do not use silicone containing acetic acid!
	DIMENSIONS (see page 46)
	FLOW DIAGRAM (see page 45)
	INSTALLATION EXAMPLE (see page 35)
	SPARE PARTS (see page 48)
	CLEANING (see page 54)
	MAINTENANCE (see page 50)
	Replace sieves (see page 50)
	Replace illuminant (see page 53)
	Electrician
	Water connection DN20 (Warm water)
	Water connection DN20 (Cold water)
	The waste drain performance must be more than 50 l/min.
	Waste
	Rain drain
	Turn on water
	turn off water
	Requires two persons.
	Hot surface!
	Safety gloves must be worn
	Eye protection must be worn
	natural sponge
	Decalcifier (Citric acid base)
	Avoid contact with eyes and skin. If this product contacts your eyes, rinse thoroughly with water.
	Electricity on/off



## INDICAZIONI SULLA SICUREZZA

- ⚠ Durante il montaggio, per evitare ferite da schiacciamento e da taglio bisogna indossare guanti protettivi.
- ⚠ Il prodotto deve essere utilizzato esclusivamente per fare il bagno e per l'igiene del corpo.
- ⚠ I bambini e gli adulti affetti da menomazioni fisiche, psichiche e/o sensoriali devono utilizzare il sistema doccia solo sotto sorveglianza. Il prodotto non deve essere utilizzato da persone sotto l'effetto di droghe o alcolici.
- ⚠ Bisogna evitare il contatto fra il getto della doccia e parti del corpo delicate (ad es. gli occhi). Fra il soffione ed il corpo va mantenuta una distanza sufficiente.
- ⚠ Attenzione! Compensare le differenze di pressione tra i collegamenti dell'acqua fredda e dell'acqua calda.

## ALLACCIAMENTO ELETTRICO

- ⚠ Il cablaggio deve essere eseguito esclusivamente da un installatore specializzato
- ⚠ Preinstallare l'alimentazione della tensione 100-240V/N/PE/50-60Hz (Lunghezza: 1 m).
- ⚠ Per protezione bisogna installare un circuito di sicurezza per correnti di guasto (RCD/FI) con una corrente differenziale nominale di  $\leq 30$  mA.
- ⚠ Il prodotto deve essere collegato a un collegamento equipotenziale (PA) 4 mm<sup>2</sup> presente in loco.

## INSTALLATORE ELETTRICISTA

- ⚠ I lavori di installazione e di controllo vanno eseguiti da un elettricista specializzato autorizzato, in considerazione delle norme VDE 0100 Parte 701, IEC 60364-6 e IEC 60364-7-701 nonché EN 60335-2-105.
- ⚠ Il cavo di allacciamento alla rete deve essere inserito con isolamento doppio nella presa di collegamento. 

## ISTRUZIONI PER IL MONTAGGIO

- / Prima del montaggio è necessario controllare che non ci siano stati danni durante il trasporto. Una volta eseguito il montaggio, non verranno riconosciuti eventuali danni di trasporto o delle superfici.
- / Montare, lavare e controllare tubature e rubinetteria rispettando le norme correnti.
- / Vanno rispettate le direttive di installazione nazionali vigenti nel rispettivo paese.
- / Per il montaggio del prodotto da personale specializzato qualificato bisogna fare attenzione, che la superficie di fissaggio, in tutto il campo di fissaggio, sia piana (nessuna giunzione sporgente o sfalsamento di piastrella), la costruzione della parete sia adatta al montaggio del prodotto e che non presenti alcun punto debole.
- / Nel praticare i fori attenzione a non danneggiare linee elettriche ed idriche!
- / Lo scarico deve essere sufficientemente dimensionato.
- / La doccia deve essere collegata solo a valle di una valvola d'arresto o di un'armatura sanitaria.

## DATI TECNICI

Pressione di servizio prima della rubinetteria:	max. 0,6 MPa
Pressione d'uso consigliata:	0,25 - 0,5 MPa (1 MPa = 10 bar = 147 PSI)
Temperatura dell'acqua calda:	max. 60°C
Temp. dell'acqua calda consigliata:	42°C
Blocco di sicurezza:	40°C

Avvertenza: il superamento di questa temperatura può causare delle ustioni!



















Disinfezione termica:	max. 70°C/4 min
Tensione nominale:	100-240V AC 50-60Hz
Assorbimento nominale:	18 W
Lampade 4 x LED:	12V DC SELV 4 W
La lampadina non è dimmerabile.	
Classe di protezione:	II
Tipo di protezione:	IPX5

ShowerHeaven 970  
Peso (con imballaggio) 47,9 kg

ShowerHeaven 720  
Peso (senza imballaggio) 28,36 kg

Il prodotto è concepito esclusivamente per acqua potabile!

## DESCRIZIONE SIMBOLO

-  Non utilizzare silicone contenente acido acetico!
-  INGOMBRI (vedi pagg. 46)
-  DIAGRAMMA FLUSSO (vedi pagg. 45)
-  ESEMPIO DI INSTALLAZIONE (vedi pagg. 35)
-  PARTI DI RICAMBIO (vedi pagg. 48)
-  PULITURA (vedi pagg. 54)
-  MANUTENZIONE (vedi pagg. 50)
-  Sostituzione vaglio (vedi pagg. 50)
-  Sostituzione lampada (vedi pagg. 53)
-  Installatore elettricista
-  Allacciamento acqua DN20 (Acqua calda)
-  Allacciamento acqua DN20 (Acqua fredda)
-  La portata di scarico deve essere superiore a 50 l/min.
-  Scarico
-  Raindrain  
Aprire l'acqua
-  Chiudere l'acqua
-  Si necessita di due lavoratori
-  Attenzione, superficie molto calda!
-  Indossare guanti di protezione
-  Indossare la protezione per gli occhi
-  spugna naturale
-  Decalcificatore (a base di acido citrico)
-  Evitare il contatto con gli occhi e la pelle. Nel caso il prodotto penetra negli occhi, sciacquarlo accuratamente con acqua.
-  Corrente ON/OFF

## INDICACIONES DE SEGURIDAD

- ⚠ Durante el montaje deben utilizarse guantes para evitar heridas por aplastamiento o corte.
- ⚠ El producto solo debe ser utilizado para fines de baño, higiene y limpieza corporal.
- ⚠ Niños, así como adultos con limitaciones corporales, mentales y/o sensoriales no deben utilizar el sistema de duchas sin vigilancia. Personas que se encuentran bajo el efecto de alcohol o drogas, no deben utilizar el sistema de duchas.
- ⚠ Debe evitarse el contacto del chorro del pulverizador con partes sensibles del cuerpo (por ej. ojos). Debe mantenerse una distancia suficiente entre pulverizador y cuerpo.
- ⚠ Grandes diferencias de presión en servicio entre agua fría y agua caliente deben equilibrarse.

## CONEXIÓN ELÉCTRICA

- ⚠ ¡Sólo un especialista está autorizado para llevar a cabo los trabajos de cableado!
- ⚠ Instalar previamente la alimentación de tensión 100-240V/N/PE/50-60Hz (longitud: 1 m).
- ⚠ La conexión debe establecerse a través de un dispositivo de protección de corriente residual (RCD/FI) con un interruptor diferencial de corriente  $\leq 30$  mA.
- ⚠ El producto tiene que ser conectado a una conexión equipotencial (PA) de 4 mm<sup>2</sup> de puesta a disposición en obra.

## INSTALADOR ELÉCTRICO

- ⚠ La instalación y las pruebas solo pueden ser realizadas por técnicos electricistas cualificados, respetando las reglamentaciones de las normas VDE 0100, parte 701, IEC 60364-6 y IEC 60364-7-701, así como la norma EN 60335-2-105.
- ⚠ El cable de conexión a la red tiene que ser conectado en la toma con aislamiento doble .

## INDICACIONES PARA EL MONTAJE

- / Antes del montaje se debe examinar el producto contra daños de transporte. Después de la instalación no se reconoce ningún daño de transporte o de superficie.
- / Los conductos y la grifería deben montarse, lavarse y comprobarse según las normas vigentes.
- / Es obligatorio el cumplimiento de las directrices de instalación vigentes en el país respectivo.
- / Durante el montaje del producto, mediante personal especializado, se debe asegurar de que la superficie de sujeción en todo el área de la fijación sea plana (sin fugas o azulejos que sobresalgan), que la estructura del muro sea adecuada para el montaje del producto y que no presente puntos débiles.
- / ¡Prestar especial atención al taladrar cerca de conductos eléctricos o de agua!
- / La tubería de desagüe ha de tener una dimensión suficiente.
- / La roseta de ducha debe conectarse siempre a una válvula de bloqueo o a valvulería sanitaria.

## DATOS TÉCNICOS

Presión de servicio delante de la grifería:	max. 0,6 MPa
Presión recomendada en servicio:	0,25 - 0,5 MPa
	(1 MPa = 10 bar = 147 PSI)
Temperatura del agua caliente:	max. 60°C
Temp. recomendada del agua caliente:	42°C
Bloqueo de seguridad:	40°C





















Aviso de peligro: si se supera esta temperatura pueden provocarse quemaduras.

Desinfección térmica:	max. 70°C / 4 min
Tensión nominal:	100-240V AC 50-60Hz
Consumo nominal:	18 W
Lámparas 4 x LED:	12V DC SELV 4 W
La lámpara no es regulable.	
Clase de protección:	II
Tipo de protección:	IPX5

ShowerHeaven 970	
Peso (con embalaje)	47,9 kg
ShowerHeaven 720	
Peso (sin embalaje)	28,36 kg

El producto ha sido concebido exclusivamente para agua potable.

## DESCRIPCIÓN DE SÍMBOLOS

	No utilizar silicona que contiene ácido acético!
	DIMENSIONES (ver página 46)
	DIAGRAMA DE CIRCULACIÓN (ver página 45)
	EJEMPLOS DE MONTAJE (ver página 35)
	REPUESTOS (ver página 48)
	LIMPIAR (ver página 54)
	MANTENIMIENTO (ver página 50)
	Cambio de tamiz (ver página 50)
	Cambio de luminarias (ver página 53)
	Instalador eléctrico
	Conexión de agua DN20 (Agua caliente)
	Conexión de agua DN20 (Agua fría)
	El caudal de desagüe debe ser como mínimo de 50 l/min
	Desagüe
	Abrir el agua
	Cerrar el agua
	Se necesitan dos operarios.
	¡Atención, superficie muy caliente!
	Protección obligatoria de la vista
	Protección obligatoria de las manos
	Esponja natural
	Descalcificador (a base de ácido cítrico)
	Evitar el contacto con ojos y piel. En caso de que el producto entre en contacto con los ojos, debe lavarlos muy bien con agua.
	Corriente on/off

## ⚠ VEILIGHEIDSinSTRUCTIES

- ⚠ Bij de montage moeten ter voorkoming van knel- en snijwonden handschoenen worden gedragen.
- ⚠ Het product mag alleen voor het wassen, hygiënische doeleinden en voor de lichaamreiniging worden gebruikt.
- ⚠ Kinderen en volwassenen met lichamelijke, geestelijke en/of sensorische beperkingen mogen het douchesysteem niet zonder toezicht gebruiken. Personen onder invloed van alcohol of drugs mogen het douchesysteem niet gebruiken.
- ⚠ Het contact van de douchestraal met gevoelige lichaamsdelen (bijv. ogen) moet worden voorkomen. Er moet voldoende afstand tussen douche en lichaam aangehouden worden.
- ⚠ Grote drukverschillen tussen de koud- en warmwatertoevoer dienen vermeden te worden.

## ELEKTRISCHE AANSLUITING

- ⚠ De elektrische aansluiting mag alleen door een vakman worden uitgevoerd!
- ⚠ Spanningsvoorziening 100-240V/N/PE/50-60Hz (lengte: 1 m) vooraf installeren.
- ⚠ Deze moet middels een 2-polige FI-schakelaar met 30mA afgezekerd worden.
- ⚠ Het product moet aangesloten worden aan een potentiaalvereffening van het gebouw (PA) van 4 mm<sup>2</sup>.

## ELECTRO-INSTALLATEUR

- ⚠ De installatie- en controlewerkzaamheden moeten uitgevoerd worden door een geautoriseerde electricien die rekening houdt met de normen VDE 0100 Deel 701, IEC 60364-6, IEC 60364-7-701 en EN 60335-2-105.
- ⚠ Het netsnoer moet dubbel geïsoleerd  in de contactdoos geleid worden.

## MONTAGE-INSTRUCTIES

- / Vóór de montage moet het product gecontroleerd worden op transportschade. Na de inbouw wordt geen transport- of oppervlakteschade meer aanvaard.
- / De leidingen en armaturen moeten gemonteerd, gespoeld en gecontroleerd worden volgens de geldige normen.
- / De in de overeenkomstige landen geldende installatierichtlijnen moeten nageleefd worden.
- / Bij de montage van het product door gekwalificeerd vakpersoneel moet erop gelet worden dat het montagevlak in het volledige bereik van de bevestiging vlak is (geen uitstekende voegen of verspringende tegels), dat de wand geschikt is voor de montage van het product en geen zwakke plaatsen vertoont.
- / Bij het boren in stroom- en waterleidingen
- / De afvoercapaciteit moet voldoende gedimensioneerd worden.
- / De douche mag enkel aangesloten worden na een afsluiklep of een sanitaire kraan.

## TECHNISCHE GEGEVENS

Stroomdruk voor de kraan:	max. 0,6 MPa
Aanbevolen werkdruk:	0,25 - 0,5 MPa
	(1 MPa = 10 bar = 147 PSI)
Temperatuur warm water:	max. 60°C
Aanbevolen warm water temp.:	42°C
Veiligheidsmechanisme:	40°C



⚠ Waarschuwing: Een overschrijding van die temperatuur kan brandwonden veroorzaken!

Thermische desinfectie:	max. 70°C / 4 min
Nominale spanning:	100-240V AC 50-60Hz
Opgenomen vermogen:	18 W
Lampjes 4 x LED:	12V DC SELV 4 W
De lamp is niet dimbaar.	
Beschermingsklasse:	II
Beveiligingsklasse:	IPX5

ShowerHeaven 970	
Gewicht (met verpakking)	47,9 kg
ShowerHeaven 720	
Gewicht (zonder verpakking)	28,36 kg

Het product is uitsluitend ontworpen voor drinkwater!

## SYMBOOLBESCHRIJVING

	Gebruik geen zuurhoudende silicone!
	MATEN (zie blz. 46)
	DOORSTROOMDIAGRAM (zie blz. 45)
	MONTAGEVOORBEELDEN (zie blz. 35)
	SERVICE ONDERDELEN (zie blz. 48)
	REINIGEN (zie blz. 54)
	ONDERHOUD (zie blz. 50)
	Filters vervangen (zie blz. 50)
	Verlichting vervangen (zie blz. 53)
	Electro-installateur
	Watersluiting DN20 (Warm water)
	Watersluiting DN20 (Koud water)
	De afvoercapaciteit moet meer dan 50 l/min bedragen.
	Afvoer
	Hoofdkraan openen
	Water afsluiten
	Twee werkrachten vereist
	Let op: heet!
	Veiligheidshandschoenen verplicht
	Oogbescherming verplicht
	Natuurzwam
	Ontkalker (citroenzuurbasis)
	Contact met huid en ogen vermijden. Indien het product in de ogen terecht komt, moet het grondig met water uitgespoeld worden.
	Stroom aan/uit



## ⚠ SIKKERHEDSANVISNINGER

- ⚠ Ved monteringen skal der bruges handsker for at undgå kvæstelser og snitsår.
- ⚠ Produktet må kun bruges til bade-, hygiejne og kropsurengøringsformål.
- ⚠ Børn som også voksne med fysiske, mentale og/eller sensoriske begrænsninger må ikke bruge brusersystemet uden opsyn. Personer som er under indflydelse af alkohol eller narkotika må ikke bruge brusersystemet.
- ⚠ Bruserstrålens kontakt med sensitive områder (f.eks. øjne) skal undgås. Der skal være en tilstrækkelig afstand mellem bruseren og kroppen.
- ⚠ Større trykforskelle mellem koldt og varmt vand bør udjævnes.

## EL-TILSLUTNING

- ⚠ Ledningsarbejde må kun foretages af en fagmand!
- ⚠ Forinstallér spændingsforsyning 100-240V/N/PE/50-60Hz (længde: 1 m).
- ⚠ Sikringen skal køre over en fejlstrømsikring (HFI) med en fejlstrømsdifference  $\leq 30$  mA.
- ⚠ Produktet skal tilsluttes til en potentialudligning (PA) 4 mm<sup>2</sup>.

## EL-INSTALLATØR

- ⚠ Installeringen og afprøvningen skal gennemføres af en godkendt el-installatør iht. VDE 0100 part 701, IEC 60364-6 og IEC 60364-7-701 samt EN 60335-2-105.
- ⚠ Nettetilslutningsledningen skal føres dobbeltisoleret  ind i tilslutningsdåsen.

## MONTERINGSANVISNINGER

- / Før monteringen skal produktet kontrolleres for transportskader. Efter monteringen godkendes transportskader eller skader på overfladen ikke længere.
- / Ledningerne og armaturerne skal monteres, skylles og kontrolleres iht. de gældende standarder.
- / Installationsbestemmelserne, der gælder i det enkelte land, skal overholdes.
- / Ved montering af produktet igennem kvalificerede fagfolk skal der holdes øje med, at fastgørelsesoverfladen er plan i alle områder hvor produktet monteres (ingen fremragende fuger eller fliseforskydninger), at væggene er velegnet til monteringen af produktet og ikke har svare områder.
- / Pas på strøm- og vandledninger ved boring!
- / Afløbet skal være i en tilstrækkelig størrelse.
- / Bruseren må kun tilsluttes efter en afspærringsventil eller et sanitæramatur.

## TEKNISKE DATA

Betjeningstryk før armaturet:	max. 0,6 MPa
Anbefalet driftstryk:	0,25 - 0,5 MPa (1 MPa = 10 bar = 147 PSI)
Varmtvandstemperatur:	max. 60°C
Anbefalet varmtvandstemperatur:	42°C
Sikkerhedsspærre:	40°C

Advarsel: Hvis temperaturen overskrides kan det føre til forbrændinger!

Termisk desinfektion:	max. 70°C/4 min
Mærkespænding:	100-240V AC 50-60Hz
Nominelt forbrug:	18 W
Lamper 4 x LED:	12V DC SELV 4 W
Lyskilden kan ikke dæmpes.	
Beskyttelsesklasse:	II
Kapslingsklasse:	IPX5

ShowerHeaven 970	
Vægt (med emballage)	47,9 kg
ShowerHeaven 720	
Vægt (uden emballage)	28,36 kg

Produktet er udelukkende beregnet til drikkevand!

## SYMBOLBESKRIVELSE



Der må ikke benyttes eddikesyreholdig silikone!



MÅLENE (se s. 46)



GENNEMSTRØMNINGSDIAGRAM (se s. 45)



MONTERINGSEKSEMPLER (se s. 35)



RESERVEDELE (se s. 48)



RENGØRING (se s. 54)



SERVICE (se s. 50)

Udskifte si (se s. 50)

Udskifte lyskilden (se s. 53)



El-installatør



Vandtilslutning DN20 (Varmt vand)



Vandtilslutning DN20 (Kold vand)



Afløbskapaciteten skal være mere end 50 l/min.



Afløb



Tænd for vandet



Luk for vandet



To personer er nødvendige



Varm overflade!



Beskyttelseshandsker påbudt



Øjenværn påbudt



Natursvamp



Afkalkningsmiddel (citronsyrebasis)

Undgå kontakt med øjne og huden. Skyl grundigt med vand, hvis produktet kommer i øjnene.



Strøm til/fra



## ⚠ AVISOS DE SEGURANÇA

- ⚠ Durante a montagem devem ser utilizadas luvas de protecção, de modo a evitar ferimentos resultantes de entalamentos e de cortes.
- ⚠ O produto só pode ser utilizado para fins de higiene pessoal.
- ⚠ Crianças e adultos com deficiências motoras, mentais e/ou sensoriais não podem utilizar o sistema de duche sem monitorização. Pessoas que estejam sob a influência de álcool ou drogas não podem utilizar o sistema de duche.
- ⚠ Deve-se evitar o contacto dos jactos de água com partes do corpo sensíveis (p. ex. olhos). É necessário manter uma distância suficiente entre o chuveiro e o corpo.
- ⚠ Grandes diferenças entre as pressões das águas quente e fria devem ser compensadas.

## LIGAÇÃO ELÉCTRICA

- ⚠ A instalação eléctrica deve ser efectuada apenas por um electricista qualificado!
- ⚠ Pré-instalar a alimentação eléctrica 100-240V/N/PE/50-60Hz (comprimento: 1 m).
- ⚠ A ligação deve estar protegida por um diferencial magneto-térmico bipolar (RRCB) com uma corrente residual  $\leq 30$  mA.
- ⚠ O produto deve ser conectado a uma ligação equipotencial (PA) 4 mm<sup>2</sup> existente.

## ELECTRICISTA DE CONSTRUÇÃO CIVIL

- ⚠ Os trabalhos de instalação e de controlo devem ser efetuados por um técnico electricista devidamente autorizado e especializado, tendo em consideração as normas VDE 0100 Parte 701, IEC 60364-6 e IEC 60364-7-701, bem como EN 60335-2-105.
- ⚠ O cabo de alimentação eléctrica deve ser inserido na t mada de ligação com um isolamento duplo .

## AVISOS DE MONTAGEM

- / Antes da montagem deve-se controlar o produto relativamente a danos de transporte. Após a montagem não são aceites quaisquer danos de transporte ou de superfície.
- / As tubagens e a torneira têm que ser montadas, enxaguadas e verificadas de acordo com as normas em vigor.
- / A prescrições de instalação válidas nos respetivos países devem ser respeitadas.
- / Durante a montagem efectuada por técnicos qualificados deve ter-se em atenção que a superfície de fixação seja plana em toda a sua extensão (sem juntas ou ladrilhos salientes), que a estrutura da parede seja adequada para a montagem do produto e que não apresente pontos fracos.
- / Ter atenção a instalações eléctricas e de água durante os trabalhos de perfuração!
- / A capacidade de escoamento deve ser devidamente dimensionada.
- / O chuveiro só pode ser instalado a seguir a uma válvula de retenção ou valvularia de sanitários.

## DADOS TÉCNICOS

Pressão de funcionamento anterior à misturadora: max. 0,6 MPa  
 Pressão de func. recomendada: 0,25 - 0,5 MPa  
 (1 MPa = 10 bar = 147 PSI)

Temperatura da água quente: max. 60°C  
 Temp. água quente recomendada: 42°C  
 Bloqueio de segurança: 40°C

**Aviso de advertência: Exceder esta temperatura pode causar queimaduras!**

Desinfecção térmica: max. 70°C/4 min  
 Tensão nominal: 100-240V AC 50-60Hz  
 Consumo nominal: 18 W  
 Lâmpadas 4 x LED: 12V DC SELV 4 W

A lâmpada não é regulável.























Classe de protecção: II  
 Tipo de protecção: IPX5

Shower Heaven 970  
 Peso (com embalagem) 47,9 kg

Shower Heaven 720  
 Peso (sem embalagem) 28,36 kg

Este produto foi única e exclusivamente concebido para água potável!

## DESCRIÇÃO DO SÍMBOLO

-  Não utilizar silicone que contenha ácido acético!
-  MEDIDAS (ver página 46)
-  FLUXOGRAMA (ver página 45)
-  EXEMPLOS DE MONTAGEM (ver página 35)
-  PEÇAS DE SUBSTITUIÇÃO (ver página 48)
-  LIMPEZA (ver página 54)
-  MANUTENÇÃO (ver página 50)
-  Substituir filtros (ver página 50)  
Substituir lâmpada (ver página 53)
-  Electricista de construção civil
-  Ligação da água DN20 (Água quente)
-  Ligação da água DN20 (Água fria)
-  Capacidade de escoamento tem que ser superior a 50 l/min.
-  Escoamento
-  Abrir a água
-  Cortar a água
-  São necessárias duas pessoas
-  Superfície quente!
-  Protecção obrigatória das mãos
-  Protecção obrigatória dos olhos
-  Esponja natural
-  Descalcificador (À base de ácido cítrico)
-  Evitar contacto com os olhos e pele. Se o produto entrar em contacto com os olhos deve lavar abundantemente com água.
-  Electricidade ligada/desligada

## WSKAZÓWKI BEZPIECZEŃSTWA

- ⚠ Aby uniknąć zranień na skutek zgniecenia lub przecięcia, podczas montażu należy nosić rękawice ochronne.
- ⚠ Produkt może być używany tylko do kąpieli, higieny i czyszczenia ciała.
- ⚠ Zarówno dzieci, jak i dorośli z fizycznymi, psychicznymi i/lub sensorycznymi ograniczeniami nie mogą korzystać z prysznica bez opieki. Osoby znajdujące się pod wpływem alkoholu lub narkotyków nie mogą korzystać z prysznica.
- ⚠ Należy unikać kontaktu strumienia wypływającego z głowicy z wrażliwymi częściami ciała (np. oczami). Należy zachowywać odpowiednią odległość pomiędzy głowicą a ciałem.
- ⚠ Znaczne różnice ciśnień na dopływach ciepłej i zimnej wody muszą zostać wyrównane.

## PRZYŁĄCZE ELEKTRYCZNE

- ⚠ Podłączenie elementów elektrycznych może być przeprowadzone jedynie przez fachowca elektryka!
- ⚠ Zainstalować zasilanie napięciowe 100-240V/N/PE/50-60Hz (Długość: 1 m).
- ⚠ Zabezpieczenie instalacji musi mieć miejsce przy użyciu zabezpieczenia różnicowego (RCD/FI) z różnicą pomiarów wynoszącą  $\leq 30$  mA.
- ⚠ Produkty należy podłączyć do ekwipotencjalizacji (PA) 4 mm<sup>2</sup> udostępnionej przez klienta.

## ELEKTRYK INSTALATOR

- ⚠ Prace instalacyjne i kontrolne mogą być przeprowadzane jedynie przez wykwalifikowanego elektryka, przestrzegając przepisów z VDE 0100 część 701, IEC 60364-6 i IEC 60364-7-701 oraz EN 60335-2-105.
- ⚠ Przewód sieciowy musi być wyposażony w podwójną izolację i wprowadzony do puszeki przyłączeniowej.

## WSKAZÓWKI MONTAŻOWE

- / Przed montażem należy skontrolować produkt pod kątem szkód transportowych. Po montażu nie widać żadnych szkód transportowych ani szkód na powierzchni.
- / Przewody i armatura muszą być montowane, płukane i kontrolowane według obowiązujących norm.
- / Należy przestrzegać wytycznych instalacyjnych obowiązujących w danym kraju.
- / Montaż produktu musi być wykonany przez wykwalifikowanego fachowca. Powierzchnia w miejscu montażu musi być równa (bez uskoków wzgl. wzajemnie przesuniętych płytek). Ściana w miejscu montażu musi być stabilna. Dokończony w komplecie śruby i kołki rozporowe są przeznaczone do betonu.
- / Podczas wiercenia uważać na instalacje elektryczne i wodne!
- / Odpływ musi mieć wystarczającą wydajność.
- / Prysznic można podłączyć tylko po użyciu zaworu odcinającego lub armatury sanitarnej.

## DANE TECHNICZNE

Ciśnienie robocze przed armaturą:	maks. 0,6 MPa
Zalecane ciśnienie robocze:	0,25 - 0,5 MPa
	(1 MPa = 10 bary = 147 PSI)
Temperatura wody gorącej:	maks. 60°C
Zalecana temperatura wody gorącej:	42°C
Blokada bezpieczeństwa:	40°C
Wskaźówka ostrzegawcza: Przekroczenie tej temperatury może prowadzić do oparzeń!	
Dezynfekcja termiczna:	maks. 70°C / 4 min
Napięcie znamionowe:	100-240V AC 50-60Hz
Nominalny pobór mocy:	18 W
Lampy 4 x LED:	12V DC SELV 4 W
Żarówki nie można ściemnić.	
Klasa ochrony:	II
Stopień ochrony:	IPX5
ShowerHeaven 970	
Ciężar (z opakowaniem)	47,9 kg
ShowerHeaven 720	
Ciężar (bez opakowania)	28,36 kg

Produkt przeznaczony wyłącznie do wody pitnej!

## OPIS SYMBOLU

-  Nie stosować silikonów zawierających kwas octowy!
-  WYMIARY (patrz strona 46)
-  SCHEMAT PRZEPŁYWU (patrz strona 45)
-  PRZYKŁADY MONTAŻOWE (patrz strona 35)
-  CZĘŚCI SERWISOWE (patrz strona 48)
-  CZYSZCZENIE (patrz strona 54)
-  KONSERWACJA (patrz strona 50)
-  Wymienić filtry sitowe (patrz strona 50)
-  Wymienić żarówki (patrz strona 53)
-  Elektryk instalator
-  Podłączenie wody DN20 (Ciepła woda)
-  Podłączenie wody DN20 (Zimna woda)
-  Wydajność odpływu musi być wyższa niż 50 l/min.
-  Odpływ
-  Otworzyć wodę
-  Zakręcić wodę
-  Potrzebni dwaj pracownicy
-  Uwaga na gorącą powierzchnię!
-  Nosić rękawice ochronne
-  Nosić okulary ochronne
-  Gąbka naturalna
-  Środek odkamieniający (na bazie kwasu cytrynowego)
-  Unikać kontaktu z oczami i skórą. Jeżeli produkt dostanie się do oczu, należy je gruntownie wypłukać wodą.
-  Wł./wyl. prąd

## ⚠ BEZPEČNOSTNÍ POKYNY

- ⚠ Pro zabránění řezným zraněním a pohmožděninám je nutné při montáži nosit rukavice.
- ⚠ Produkt smí být používán pouze ke koupání a za účelem tělesné hygieny.
- ⚠ Děti a dospělí osoby s tělesným, duševním a/nebo smyslovým postižením nesmí produkt používat bez dozoru. Osoby pod vlivem alkoholu nebo drog nesmí produkt používat.
- ⚠ Je nutné zabránit kontaktu vodních paprsků sprchy s měkkými částmi těla (např. očima). Je nutné dodržovat dostatečný odstup mezi sprchou a tělem.
- ⚠ Je nutné vyrovnat velké rozdíly tlaku mezi přípoji studené a teplé vody.

## ELEKTRICKÉ PŘIPOJENÍ

- ⚠ Elektroinstalace smí být provedena jen kvalifikovaným elektrikářem!
- ⚠ Zdroj napětí 100-240V/N/PE/50-60Hz (délka: 1 m) předinstalovat.
- ⚠ Přívod musí být chráněn proudovým chráničem pro chybový proud (RCD/FI) s mírným rozdílovým proudem  $\leq 30$  mA.
- ⚠ Produkt musí být připojen k vyrovnání potenciálu (PA) 4 mm<sup>2</sup> nainstalovanému provozovatelem.

## ELEKTROINSTALATÉR

- ⚠ Instalační práce a přezkoušení musí být provedeno autorizovaným elektrotechnickým odborníkem za zohlednění směrnice VDE 0100, část 701, IEC 60364-6 a IEC 60364-7-701 a také EN 60335-2-105.
- ⚠ Připojovací síťové vedení musí být zavedeno do krabic přípojky tak, aby bylo dvojitě odizolované .

## POKYNY K MONTÁŽI

- / Před montáží je třeba produkt zkontrolovat, zda nebyl při transportu poškozen. Po zabudování nebudou uznány žádné škody způsobené transportem nebo poškození povrchu.
- / Vedení a armatura musí být namontovány, propláchnuty a otestovány podle platných norem.
- / Je třeba dodržovat montážní pravidla platná v dané zemi.
- / Při montáži produktu kvalifikovanou osobou je třeba dbát na to, aby byla upevňovací plocha v celé oblasti upevnění rovná (žádné vyčnívající spáry nebo zapuštěné obklady), aby struktura stěny byla vhodná pro montáž produktu a neměla žádná slabá místa.
- / Při vrtání dejte pozor na elektrická vedení a vodovodní potrubí!
- / Propustnost odpadu musí být dostatečně dimenzována.
- / Sprcha smí být připojena pouze za uzavíracím ventilem nebo sanitární armaturou.

## TECHNICKÉ ÚDAJE

Provozní tlak před armaturou: max. 0,6 MPa  
 Doporučený provozní tlak: 0,25 - 0,5 MPa  
 (1 MPa = 10 bar = 147 PSI)

Teplota horké vody: max. 60°C  
 Doporučená teplota horké vody: 42°C  
 Bezpečnostní zámeček: 40°C

Varování: Překročení této teploty může vést k popálení námi!

Tepelná desinfekce: max. 70°C / 4 min  
 Nízké napětí: 100-240V AC 50-60Hz  
 Jmenovitý proud: 18 W  
 Svítidla 4 x LED: 12V DC SELV 4 W

Světlo není regulovatelné.

























Třída ochrany: II  
 Třída krytí: IPX5

Shower Heaven 970  
 Hmotnost (s obalem) 47,9 kg

Shower Heaven 720  
 Hmotnost (bez obalu) 28,36 kg

Výrobky Hansgrohe jsou vhodné pro přímý kontakt s pitnou vodou.

## POPIS SYMBOLŮ

-  Nepoužívat silikon s obsahem kyseliny octové!
-  ROZMĚRY (viz strana 46)
-  DIAGRAM PRŮTOKU (viz strana 45)
-  PŘÍKLADY MONTÁŽE (viz strana 35)
-  SERVISNÍ DÍLY (viz strana 48)
-  ČIŠTĚNÍ (viz strana 54)
-  ÚDRŽBA (viz strana 50)
-  Výměna sítek (viz strana 50)
-  Výměna svítidel (viz strana 53)
-  Elektroinstalatér
-  Připojení vody DN20 (Teplá voda)
-  Připojení vody DN20 (Studená voda)
-  Odtokový výkon musí být vyšší než 50 l/min.
-  Odtok
-  Vodu zapojit
-  Vodu odpojit
-  Je třeba dvou pracovních sil
-  Pozor, horký povrch!
-  Noste ochranné rukavice
-  Noste ochranné brýle
-  Přírodní mořská houba
-  Odvápňovač (báze kyseliny citrónové)
-  Zabraňte styku s pokožkou a očima. Zasažne-li výrobek oči, důkladně je vypláchněte vodou.
-  Elektrický proud ZAP/VYP

## △ BEZPEČNOSTNÉ POKYNY

- △ Pri montáži musíte nosiť rukavice, aby ste predišli pomliaždeninám a rezným poraneniam.
- △ Produkt sa smie používať len na kúpanie a telesnú hygienu.
- △ Produkt nesmú bez dozoru používať deti, ako aj dospelé osoby s telesným, duševným a/alebo zmyslovým postihnutím. Produkt nesmú používať ani osoby, ktoré sú pod vplyvom alkoholu alebo drog.
- △ Vyhýbajte sa kontaktu vodného lúča sprchy s citlivými miestami tela (napr. oči). Dodržiavajte dostatočnú vzdialenosť medzi sprchou a telom.
- △ Veľké rozdiely v tlaku medzi prípojkami studenej a teplej vody musia byť vyrovnané.

## ELEKTRICKÉ PRIPOJENIE

- △ Elektroinštalácia môže byť vykonaná len kvalifikovaným elektrikárom!
- △ Predinštalujte napájanie napätím 100-240V/N/PE/50-60Hz (dĺžka: 1 m).
- △ Prívod musí byť chránený prúdovým chráničom (RCD/FI) pre chybový prúd s merným rozdielovým prúdom  $\leq 30$  mA.
- △ Výrobok sa musí pripojiť na vyrovnanie potenciálov (PA) 4 mm<sup>2</sup> prítomné zo strany stavby.

## ELEKTROINŠTALATÉR

- △ Inštalážna a skúšobná práca musí vykonávať len autorizovaný elektrikár pri zohľadnení noriem VDE 0100 časť 701, IEC 60364-6 a IEC 60364-7-701, ako aj EN 60335-2-105.
- △ Sieťové prípojné vedenie sa musí viesť do prípojnej kabice s dvojitou izoláciou .

## POKYNY PRE MONTÁŽ

- / Pred montážou musíte produkt skontrolovať, či nebol počas transportu poškodený. Po zabudovaní nebudú uznané žiadne škody spôsobené transportom alebo poškodenia povrchu.
- / Potrubia a vybavenie musia byť namontované, prepláchnuté a vybavené v platnom normami.
- / Je potrebné dodržiavať smernice o inštalácii, ktoré sú práve teraz platné v krajinách.
- / Pri montáži produktu kvalifikovanou osobou treba dávať pozor na to, aby bola upevňovacia plocha v celej oblasti upevnenia rovná (žiadne vyčnievajúce medzery alebo zapustenia obkladov), aby štruktúra steny bola vhodná pre montáž produktu a nemá žiadne slabé miesta.
- / Pri vŕtaní dajte pozor na elektrické vedenia a vodovodné potrubia!
- / Priepustnosť odpadu musí byť dostatočne dimenzovaná.
- / Sprchu je možné napojiť len na uzatvárací ventil alebo na sanitárnu armatúru.

## TECHNICKÉ ÚDAJE

Prevádzkový tlak pred armatúrou: max. 0,6 MPa  
 Doporučený prevádzkový tlak: 0,25 - 0,5 MPa  
 (1 MPa = 10 bar = 147 PSI)

Teplota teplej vody: max. 60°C  
 Doporučená teplota teplej vody: 42°C  
 Bezpečnostný zámok: 40°C

Varovanie: Prekročenie tejto teploty môže viesť k popáleninám!

Termická dezinfekcia: max. 70°C / 4 min  
 Menovité napätie: 100-240V AC 50-60Hz  
 Menovitý príkon: 18 W  
 Svietidlá 4 x LED: 12V DC SELV 4 W

Osvetľovací prostriedok je stmievateľný.

Trieda ochrany: II  
 Trieda ochrany: IPX5

Shower Heaven 970  
 Hmotnosť (s obalom) 47,9 kg

Shower Heaven 720  
 Hmotnosť (bez obalu) 28,36 kg

Výrobok je koncipovaný výhradne pre pitnú vodu!

## POPIS SYMBOLOV

-  Nepoužívať silikón s obsahom kyseliny octovej!
-  ROZMERY (viď strana 46)
-  DIAGRAM PRIETOKU (viď strana 45)
-  PRÍKLADY MONTÁŽE (viď strana 35)
-  SERVISNÉ DIELY (viď strana 48)
-  ČISTENIE (viď strana 54)
-  ÚDRŽBA (viď strana 50)
-  Výmena sít (viď strana 50)
-  Výmena svietidiel (viď strana 53)
-  Elektroinštalatér
-  Pripojenie vody DN20 (Teplá voda)
-  Pripojenie vody DN20 (Studená voda)
-  Výkon odtoku musí byť vyšší ako 50 l/min.
-  Odtok
-  Zapojiť vodu
-  Odpojiť vodu
-  Sú potrebné dve pracovné sily
-  Pozor, horúci vzduch!
-  Noste ochranné rukavice
-  Noste ochranné okuliare
-  Prírodná morská huba
-  Odvápňovač (báza kyseliny citrónovej)
-  Zabráňte styku s pokožkou a očami. Ak produkt zasiahne oči, dôkladne ich vypláchnite vodou.
-  Zap./vyp. prúd

### △ 安全技巧

- △ 装配时为避免挤压和切割受伤，必须戴上手套。
- △ 本产品只允许作为洗浴、卫生和洁身之用。
- △ 不得让儿童和肢体、精神和或意识有障碍的成人在不受监管的情况下使用淋浴系统。受酒精或毒品影响的人员不得使用淋浴系统。
- △ 必须避免让身体敏感部位 (如眼睛) 接触到莲蓬头喷水。必须保持莲蓬头与人头之间有充分的距离。
- △ 冷热水管间过大的压力差必须予以平衡。

### 电气连接

- △ 电气接口只能由电气专业人员进行操作！
- △ 预安装电源电压 100-240V/N/PE/50-60Hz (长度: 1 m)。
- △ 保险装置必须是额定电流  $\leq 30$  mA 的故障电流保护装置。
- △ 产品必须连接施工方现有的电位补偿(PA) 4 mm。

### 电气安装人员

- △ 安装和检查工作由有资质的电气专业人员按照德国电气工程协会VDE 0100标准中第701项和国际电工委员会 IEC 60364-6项和国际电工委员会 IEC 60364-7-701标准以及欧洲标准60335-2-105执行。
- △ 必须使电源线双重绝缘  并插入接线盒。

### 安装提示

- / 安装前必须检查产品是否受到运输损害。安装后将不认可运输损害或表面损伤。
- / 管道和阀门必须根据通用标准进行安装、冲洗和检查。
- / 请遵守当地国家现行的安装规定。
- / 由有资格的专业人员进行产品安装时请注意：在所有加固区域中，加固表面是否平整 (无突出的接缝或瓷砖)，墙体结构是否适合产品安装且未显露出任何缺点。
- / 钻孔时请注意电线和水管！
- / 废水管的性能必须具有充足的尺寸。
- / 该花洒仅允许连接在卫浴龙头或截止阀之后。

### 技术参数

花洒接头前方的操作压力:	最大 0,6 MPa
推荐工作压力:	0,25 - 0,5 MPa (1 MPa = 10 bar = 147 PSI)
热水温度:	最大 60°C
推荐热水温度:	42°C
安全止动器:	40°C
警告: 温度过高会引发燃烧危险!	
热力消毒:	最大 70°C / 4 分钟
额定电压:	100-240V AC 50-60Hz
额定输入:	18 W
灯 4 x LED:	12V DC SELV 4 W
灯具不可调光。	
保护等级:	II
保护等级:	IPX5
ShowerHeaven 970	
重量 (含包装)	47,9 kg
ShowerHeaven 720	
重量 (不含包装)	28,36 kg

该产品专为饮用水设计！

### 符号说明

-  请勿使用含有乙酸的硅胶！
-  大小 (参见第页 46)
-  流量示意图 (参见第页 45)
-  安装示意 (参见第页 35)
-  备用零件 (参见第页 48)
-  清洗 (参见第页 54)
-  保养 (参见第页 50)
-  更换滤网 (参见第页 50)
-  更换灯具 (参见第页 53)
-  电气安装人员
-  水连接 DN20 (热水)
-  水连接 DN20 (冷水)
-  排水功率必须大于 50 l/min.
-  排水口
-  调节水
-  关闭水流
-  需要两个劳动力
-  热表面！
-  配戴保护手套
-  配戴护眼用具
-  天然海绵
-  柔软剂 (柠檬酸)
-  避免眼睛和皮肤接触。如该产品不慎进入眼睛，立即用清水彻底冲洗。
-  电流 接通断开

## УКАЗАНИЯ ПО ТЕХНИКЕ БЕЗОПАСНОСТИ

- ⚠ Во время монтажа следует надеть перчатки во избежание прищемления и порезов.
- ⚠ Изделие разрешается использовать только в гигиенических целях: для принятия ванны и личной гигиены.
- ⚠ Дети, а также взрослые с физическими, умственными и/или сенсорными недостатками должны пользоваться изделием только под присмотром. Запрещается пользоваться изделием в состоянии алкогольного или наркотического опьянения.
- ⚠ Не допускайте попадания струи воды из разбрызгивателя на чувствительные части тела (например, на глаза). Разбрызгиватель следует устанавливать на достаточном расстоянии от тела.
- ⚠ донного клапа. Перед установкой смесителя необходимо регулировочными кранами выровнять авление холодной и горячей воды при помощи вентилей регулирующих подачу воды в квартиру.

## ЭЛЕКТРОПОДКЛЮЧЕНИЕ

- ⚠ Электрическое подключение разрешается выполнять только специалисту-электрику!
- ⚠ Питание 100-240В/Н/PE/50-60Гц (длина: 1 м) установить предварительно.
- ⚠ Требуется организовать защиту с помощью устройства защитного отключения (выключателя дифференциального тока) с уставкой дифференциального тока  $\leq 30$  мА.
- ⚠ Изделие нужно подключить к выравнивателю потенциалов (РА) 4 мм<sup>2</sup>, предусмотренному заказчиком.

## ЭЛЕКТРОМОНТЕР

- ⚠ Установочные и проверочные работы проводятся специалистами-электриками, имеющими допуск к работе, с соблюдением VDE 0100, часть 701, IEC 60364-6, IEC 60364-7-701 и EN 60335-2-105.
- ⚠ Провод для подключения к сети нужно вставить в розетку с двойной изоляцией.

## УКАЗАНИЯ ПО МОНТАЖУ

- / Перед монтажом следует проверить изделие на предмет повреждений при перевозке. После монтажа претензии о возмещении ущерба за повреждения при перевозке или повреждения поверхностей не принимаются.
- / Трубы и арматура должны быть установлены, промыты и проверены в соответствии с действующими нормами.
- / Необходимо соблюдать требования по монтажу, действующие в соответствующих странах.
- / Во время монтажа изделия квалифицированным персоналом поверхность крепления должна быть ровной по всей области крепления (не допускайте выступающих стыков или перекоса облицовочной плитки); для монтажа изделия следует использовать подходящую стену достаточной прочности.
- / При сверлении обратить внимание на проложенные трубы или электрический кабель!
- / Слив должен иметь достаточную производительность.
- / Источник разбрызгивания должен подсоединяться только после запорного клапана или санитарной арматуры.

## ТЕХНИЧЕСКИЕ ДАННЫЕ

Рабочее давление в смесителе:	не более 0,6 МПа
Рекомендуемое рабочее давление:	0,25 - 0,5 МПа (1 МПа = 10 bar = 147 PSI)
Температура горячей воды:	не более 60°C
Рекомендуемая темп. гор. воды:	42°C
Предохранительный фиксатор:	40°C
Предупреждение. Превышение этой температуры может привести к ожогам!	
Термическая дезинфекция:	не более 70°C/4 мин
Номинальное напряжение:	100-240V AC 50-60Hz
номинальное потребление:	18 W
Светильники 4 x LED:	12V DC SELV 4 W
Яркость лампочки не регулируется.	
Степень защиты:	II
Тип защиты:	IPX5
ShowerHeaven 970	
Вес (с упаковкой)	479 kg
ShowerHeaven 720	

МОНТАЖ (см. стр. 37)



Вес (без упаковки)

28,36 kg

Изделие предназначено исключительно для питьевой воды!

## ОПИСАНИЕ СИМВОЛОВ

- Не применяйте силикон, содержащий уксусную кислоту.
- РАЗМЕРЫ (см. стр. 46)
- СХЕМА ПОТОКА (см. стр. 45)
- ВАРИАНТЫ УСТАНОВКИ (см. стр. 35)
- КОМПЛЕКТ (см. стр. 48)
- ОЧИСТКА (см. стр. 54)
- ТЕХНИЧЕСКОЕ ОБСЛУЖИВАНИЕ (см. стр. 50)
- Замена решеток (см. стр. 50)
- Замена источника света (см. стр. 53)
- Электромонтер
- Подключение воды DN20 (Теплая вода)
- Подключение воды DN20 (Холодная вода)
- Слив должен иметь производительность более 50 л/мин.
- Слив
- откройте воду
- Закройте воду
- Требуется два человека
- Осторожно! Горячая поверхность!
- Носите защитные перчатки
- Носите средства защиты глаз
- Губка из натурального волокна
- Удалитель накипи (на основе лимонной кислоты)
- Избегайте контакта с глазами и кожей. При попадании продукта в глаза, тщательно промойте их водой.
- Ток вкл./выкл.

## △ TURVALLISUUSOHJEET

- △ Asennuksessa on käytettävä käsiineitä puristumien ja viiltojen aiheuttamien tapaturmien estämiseksi.
- △ Tuotetta saa käyttää ainoastaan kylpy-, hygienia- ja puhdistustarkoituksiin.
- △ Lapset ja ruumiillisesti, henkisesti ja/tai aistillisesti rajoittuneet aikuiset eivät saa käyttää suihkujärjestelmää ilman valvontaa. Alkoholin tai huumeiden vaikutuksessa olevat henkilöt eivät saa käyttää suihkujärjestelmää.
- △ Suihkuveden kontaktia herkkien ruumiinosien (esim. silmien) kanssa on vältettävä. Suihkun ja vartalon välissä on oltava riittävä väli.
- △ Suuret paine-erot kylmä- ja kuumavesiliitäntöjen välillä on tasattava.

## SÄHKÖLIITÄNTÄ

- △ Sähköliitännän saa tehdä vain sähköalan ammattilainen!
- △ Esiasenna jännitteensyöttö 100-240V/N/PE/50-60Hz (pituus: 1,0 m).
- △ Varmistus on tehtävä vikavirta-suojalaitetta (RCD/FI), jonka vikavirta-asetus on  $\leq 30$  mA, käyttäen.
- △ Tuote pitää liittää rakennuksessa olevaan potentiaalitasaukseen (PA) 4 mm<sup>2</sup>.

## SÄHKÖASENTAJA

- △ Hyväksytyin sähköammattilaisen on suoritettava sähköasennus- ja tarkastustyöt VDE 0100 osa 701, IEC 60364-6 ja IEC 60364-7-701 sekä EN 60335-2-105 mukaisesti.
- △ Sen verkkoliitäntäjohdon, johon liitäntärasia liitetään, tulee olla kaksoiseristetty .

## ASENNUSOHJEET

- / Ennen asennusta on tarkastettava tuotteen mahdolliset kuljetusvahingot. Asennuksen jälkeen kuljetus- ja pintavaurioita ei hyväksytä.
- / Putket ja hana on asennettava, huuhdeltava ja tarkastettava voimassa olevien standardien mukaisesti.
- / Jokaisessa maassa on noudatettava siellä päteviä asennusohjeita.
- / Pätevän ammattihenkilöstön asentaessa tuotetta on otettava huomioon, että kiinnityspinnan on oltava koko kiinnitysalueelta tasainen (ei korkeita saumoja tai laattojen yhtymäkohtia), seinän rakenne soveltuu tuotteen asennukseen eikä siinä ole heikkoja kohtia.
- / Varo porattaessa sähkö- ja vesijohtoja!
- / Poisvirtausteho on mitoitettava riittävän suureksi.
- / Suihkun saa liittää vain sulkuventtiiliin tai saniteettiarmatuuriin.

## TEKNISET TIEDOT

Käyttöpaine ennen kalustetta:	maks. 0,6 MPa
Suosittelut käyttöpaine:	0,25 - 0,5 MPa
	(1 MPa = 10 bar = 147 PSI)
Kuuman veden lämpötila:	maks. 60°C
Kuuman veden suosituslämpötila:	42°C
Turvaestin:	40°C

Varoitus: Tämän lämpötilan ylittäminen voi aiheuttaa

palovammoja!

Lämpödesinfektio:	maks. 70°C / 4 min
Nimellijännite:	100-240V AC 50-60Hz
Nimellisoteho:	18 W
Valaisimet 4 x LED:	12V DC SELV 4 W
Valaisin ei ole himmennettävissä.	
Suojausluokka:	II
Suojausluokka:	IPX5

ShowerHeaven 970  
Paino (pakkauksen kanssa) 47,9 kg

ShowerHeaven 720  
Paino (ilman pakkausta) 28,36 kg

Tuote on suunniteltu käytettäväksi ainoastaan juomaveden kanssa!

## MERKIN KUVAUS

-  Älä käytä etikkahappopitoista silikonia!
-  MITAT (katso sivu 46)
-  VIRTAUDIAGRAMMI (katso sivu 45)
-  ASENNUSESIMERKKEJÄ (katso sivu 35)
-  VARAOSAT (katso sivu 48)
-  PUHDISTUS (katso sivu 54)
-  HUOLTO (katso sivu 50)
-  Siivilöiden vaihto (katso sivu 50)
-  Valonlähteen vaihto (katso sivu 53)
-  Sähköasentaja
-  Vesiliitäntä DN20 (Lämmin vesi)
-  Vesiliitäntä DN20 (Kylmä vesi)
-  Poisvirtaustehon on oltava enemmän kuin 50l/min.
-  Veden poisvirtaus
-  Avaa vedensyöttö
-  Sulje vedentulo
-  Tarvitaan kaksi työntekijää
-  Varoitus kuumasta pinnasta!
-  Käytä suojakäsineitä
-  Käytä silmäsuojuksia
-  Luonnonsieni
-  Kalkinpoistaja (sitruunahappopohjainen)
-  Vältä silmä- ja ihokosketusta. Jos tuotetta pääsee silmiin, huuhtelee silmät perusteellisesti vedellä.
-  Sähkö päällä / pois päältä



## △ SÄKERHETSANVISNINGAR

- △ Handskar ska bäras under monteringsarbetet så att man kan undvika kläm- och skärskador.
- △ Produkten får bara användas till kroppshygien med bad och dusch.
- △ Barn samt vuxna med fysiska, psykiska eller sensoriska funktionshinder får inte använda produkten ensamma. Personer som är påverkade av alkohol- eller droger får inte använda produkten.
- △ Undvik att rikta duschstrålarna mot känsliga kroppsdelar (t. ex. ögonen). Det måste finnas ett tillräckligt stort avstånd mellan duschen och kroppen.
- △ Stora tryckskillnader mellan anslutningarna för varmt och kallt vatten måste utjämnas.

## ELEKTRISK ANSLUTNING

- △ Elanslutningen får endast utföras av en elektroinstallatör!
- △ Förinstallera nätspänning 100-240V/N/PE/50-60Hz (längd: 1 m).
- △ Säkringen måste ske via en felströms-skyddsanordning (RCD/FI) med en differensström på  $\leq 30$  mA.
- △ Produkten ska anslutas till en på plats befintlig potentialutjämning (PA) 4 mm<sup>2</sup>.

## ELINSTALLATÖR

- △ Installations- och kontrollarbeten ska utföras av behörig elektroinstallatör, enligt VDE 0100 del 701, IEC 60364-6 o. IEC 60364-7-701 samt EN 60335-2-105.
- △ Nätkabeln ska införas dubbelt isolerad  i koppling dosan.

## MONTERINGSANVISNINGAR

- / Det måste undersökas om produkten har transportskador innan den monteras. Efter monteringen accepteras inga transport- eller ytskiktsskador.
- / Ledningarna och blandaren måste monteras, spolats igenom och kontrolleras enligt de gällande normerna.
- / De installationsriktlinjer som gäller i länderna ska följas.
- / När kvalificerad fackpersonal monterar produkten är det viktigt att fästyten är plan över hela fastsättningsområdet (inga fogar som sticker ut eller kakelförskjutning) och att väggstrukturen är lämplig för en montering av produkten och inte har några svaga punkter.
- / Tänk på elledningarna och vattenrör vid borrhål!
- / Tömningskapaciteten måste vara tillräcklig.
- / Duschen får bara anslutas efter en spärrventil eller sanitärblandare.

## TEKNISKA DATA

Driftstryck framför blandaren:	max. 0,6 MPa
Rek. driftstryck:	0,25 - 0,5 MPa
	(1 MPa = 10 bar = 147 PSI)
Varmvattentemperatur:	max. 60°C
Rek. varmvattentemp.:	42°C
Säkerhetsspärr:	40°C

Varning: om angiven temperatur överskrids kan detta leda till förbränningar!

Termisk desinfektion:	max. 70°C/4 min
Nominell spänning:	100-240V AC 50-60Hz
Nominell förbrukning:	18 W
Lampa 4 x LED:	12V DC SELV 4 W
Lampan kan inte dimmas.	
Skyddsklass:	II
Skyddstyp:	IPX5

ShowerHeaven 970  
Vikt (med förpackning) 47,9 kg

ShowerHeaven 720  
Vikt (utan förpackning) 28,36 kg

Produkten är enbart avsedd för dricksvatten!

## SYMBOLFÖRKLARING



Använd inte silikon som innehåller ättiksyra!



MÅTTEN (se sidan 46)



FLÖDESSHEMA (se sidan 45)



MONTERINGSEXEMPEL (se sidan 35)



RESERVDELAR (se sidan 48)



RENGÖRING (se sidan 54)



SKÖTSEL (se sidan 50)

Byta silar (se sidan 50)

Byta glödlampa (se sidan 53)



Elinstallatör



Vattenanslutning DN20 (Varmvatten)



Vattenanslutning DN20 (Kallvatten)



Avloppet måste klara mer än 50 l/min.



Avlopp



Slå på vatten



Stäng av vattnet



Det krävs två personer



Varning för het yta!



Bär skyddshandskar



Bär ögonskydd



Natursvamp



Avkalkningsmedel (citronsyra)

Undvik ögon- och hudkontakt. Skulle produkten hamna i ögonen så spola ur dem grundligt med vatten.



Ström på/av



## SAUGUMO TECHNIKOS NURODYMAI

- ⚠ Apsaugai nuo užspaudimo ir įsipjovimo montavimo metu mūvėkite pirštines.
- ⚠ Gaminys turi būti naudojamas tik maudymuisi, kūno higienai ir švarai palaikyti.
- ⚠ Gaminį draudžiama naudoti vaikams, taip pat suaugusiems su fizine, dvasine negale ir (arba) sensorikos sutrikimais. Gaminį taip pat draudžiama naudoti asmenims, apsvaigusiems nuo alkoholio arba narkotikų.
- ⚠ Būtina vengti dušo vandens srovės kontakto su jautriomis kūno vietomis (pvz., akimis). Todėl būtina laikytis tinkamo atstumo nuo dušo.
- ⚠ Turi būti išlyginti šalto ir karšto slėgio nelygumai.

## ELEKTROS PRIJUNGIMAS

- ⚠ Elektrą prijungti turi elektrikas!
- ⚠ Iš anksto parenkite maitinimo šaltinį 100-240V/N/PE/50-60Hz (1 m ilgio).
- ⚠ Apsauginis įrenginys (RCD/FI) apsaugo nuo nebalanso srovės, kai srovių skirtumas  $\leq 30$  mA.
- ⚠ Gaminį reikia prijungti prie montavimo vietoje esančio potencialų išlyginimo įtaiso (PA) 4 mm<sup>2</sup>.

## ELEKTROMONTUOTOJAS

- ⚠ Įrengimo ir tikrinimo darbus gali atlikti tik kvalifikuoti elektrikai pagal VDE 0100 701 d. ir IEC 60364-7-701, IEC 60364-6 bei 60335-2-105 standartų reikalavimus.
- ⚠ Dvigubai izoliuotą prijungimo prie tinklo laidą  įveskite į jungiamąjį lizdą.

## MONTAVIMO INSTRUKCIJA

- / Prieš montuojant būtina patikrinti, ar gaminys nebuvo pažeistas transportavimo metu. Sumontavus pretenzijos dėl transportavimo ir paviršiaus pažeidimų nepriimamos.
- / Vamzdžiai ir sujungimai turi būti montuojami, plaunami ir tikrinami pagal galiojančias normas.
- / Laikykitės atitinkamoje šalyje galiojančių direktyvų dėl įrengimo.
- / Atlikdami montavimo darbus, kvalifikuoti darbuotojai turi atkreipti dėmesį, kad pritvirtinimo plokštuma būtų lygi (be išsikišusių siūlių ar perkreiptų plytelių), sienų konstrukcija tiktų gaminiui montuoti ir neturėtų jokių trūkumų.
- / Grežiant atkreipkite dėmesį į esamas elektros ir vandens linijas
- / Vandens nubėgimas privalo būti pakankamas.
- / Dušo galvą galima prijungti tik už uždarymo vožtuvo arba sanitarinio maišytuvo.

## TECHNINIAI DUOMENYS

Darbinis slėgis prieš maišytuvą:	ne daugiau kaip 0,6 MPa
Rekomenduojamas slėgis:	0,25 - 0,5 MPa (1 MPa = 10 barų = 147 PSI)
Karšto vandens temperatūra:	ne daugiau kaip 60°C
Rekomenduojama karšto vandens temperatūra:	42°C
Apsauginė blokuotė:	40°C

Įspėjimas: dėl padidėjusios temperatūros kyla nudegimų grėsmė!

Terminis dezinfekavimas:	ne daugiau kaip 70°C / 4 min
Nominali įtampa:	100-240V AC 50-60Hz
Nominalioji imamoji galia:	18 W
Šviestuvai 4 x LED:	12V DC SELV 4 W
Žibinto šviesos ryškumas nereguliuojamas.	
Apsaugos klasė:	II
Apsaugos tipas:	IPX5

Shower Heaven 970  
Svoris (su įpakavimu) 47,9 kg

Shower Heaven 720  
Svoris (be įpakavimo) 28,36 kg

Produktas skirtas tik geriamajam vandeniui!

## SIMBOLIO APRAŠYMAS

-  Nenaudokite silikono, kurio sudėtyje yra acto rūgšties!
-  IŠMATAVIMAI (žr. psl. 46)
-  PRALAUDIMO DIAGRAMA (žr. psl. 45)
-  MONTAVIMO PAVYZDŽIAI (žr. psl. 35)
-  ATSARGINĖS DALYS (žr. psl. 48)
-  VALYMAS (žr. psl. 54)
-  TECHNINIS APTARNAVIMAS (žr. psl. 50)
-  Tinklelio pakeitimas (žr. psl. 50)
-  Šviesos šaltinio pakeitimas (žr. psl. 53)
-  Elektromontuotojas
-  Vandens prijungimas DN20 (Šiltas vanduo)
-  Vandens prijungimas DN20 (Šaltas vanduo)
-  Nutekėjimo našumas turi būti ne mažesnis 50 l/min
-  Nutekėjimas
-  Raindrain
-  Įjunkite vandens tiekimą
-  Išjungti vandens tiekimą
-  Darbus turi atlikti du kvalifikuoti darbuotojai
-  Karštas paviršius!
-  Mūvėkite apsaugines pirštines
-  Dėvėkite akių apsaugines priemones
-  Natūrali kempinė
-  Nukalkintojas (citrinų rūgšties pagrindu)
-  Venkite, kad produkto nepatektų į akis ir ant odos. Patekus į akis, jas kruopščiai nuplaukite vandeniu.
-  Srovė į/iš.

## △ SIGURNOSNE UPUTE

- △ Prilikom montaže se radi sprječavanja prignječenja i posjekotina moraju nositi rukavice.
- △ Proizvod se smije primjenjivati samo za kupanje, tuširanje i osobnu higijenu.
- △ Djeca, kao i tjelesno, mentalno i/ili senzorno hendikepirane odrasle osobe ne smiju se koristiti proizvodom bez nadzora. Osobe koje su pod utjecajem alkohola ili droga ne smiju se koristiti proizvodom.
- △ Mora se izbjegavati kontakt mlaza iz tuša s osjetljivim dijelovima tijela (npr. očima). Tijelo korisnika mora biti dovoljno udaljeno od tuša.
- △ Velika razlika u pritisku između vruće i hladne vode mora biti izbalansirana.

## ELEKTRIČNI PRIKLJUČAK

- △ Električku smije priključiti samo ovlašteni električar!
- △ Prethodno priključite naponsko napajanje 100-240V/N/PE/50-60Hz (duljina: 1 m).
- △ Vod se mora osigurati nadstrujnom zaštitnom sklopkom (RCD/FI) s nazivnom diferencijalnom strujom  $\leq 30$  mA.
- △ Proizvod se mora priključiti na postojeće izjednačenje potencijala (PA) 4 mm<sup>2</sup>.

## ELEKTROINSTALATER

- △ Električne instalacijske i ispitne radove smiju obavljati samo certificirani električari uz uvažavanje odredaba VDE 0100 dio 701, IEC 60364-6 i IEC 60364-7-701 te EN 60335-2-105.
- △ Strujni priključni kabel mora se dvostruko izoliran  uvesti u priključnicu.

## UPUTE ZA MONTAŽU

- / Prije montaže mora se provjeriti je li proizvod oštećen prilikom transporta. Nakon ugradnje se ne priznaju nikakve reklamacije koje se odnose na površinska i transportna oštećenja.
- / Cijevi i armatura moraju biti postavljeni, isprani i testirani prema važećim normama.
- / Obvezno se moraju uvažiti propisi o instalacijama koji vrijede u dotičnoj zemlji.
- / Kada proizvod montira kvalificirano stručno osoblje treba paziti da čitava površina na koju se učvršćuje bude ravna (bez istaknutih fuga ili krivljenja pločica), da je zidna konstrukcija primjerena montaži proizvoda te da nema slabih mjesta.
- / Prilikom bušenja treba paziti na strujne vodove i vodovodne cijevi!
- / Potreban je optimalan protok vode
- / Tuš se smije priključivati samo iza zapornog ventila ili iza sanitarne armature.

## TEHNIČKI PODATCI

Radni tlak ispred armature:	tlak 0,6 MPa
Preporučeni tlak:	0,25 - 0,5 MPa (1 MPa = 10 bar = 147 PSI)
Temperatura vruće vode:	tlak 60°C
Preporučena temperatura vruće vode:	42°C
Sigurnosni zapor:	40°C

Upozorenje: Prekoračenje ove temperature može izazvati opekline!





Termička dezinfekcija:	tlak 70°C / 4 min
Nazivni napon:	100-240V AC 50-60Hz
Nazivna potrošnja:	18 W
Svjetiljke 4 x LED:	12V DC SELV 4 W
Svjetiljka se ne može prigušiti.	
Stupanj zaštite:	II
Stupanj zaštite:	IPX5

Shower Heaven 970  
Bruto težina 47,9 kg

Shower Heaven 720  
Neto težina 28,36 kg

Proizvod je koncipiran isključivo za pitku vodu!

## OPIS SIMBOLA

-  Nemojte koristiti silikon koji sadrži octenu kiselinu!
-  MJERE (pogledaj stranicu 46)
-  DIJAGRAM PROTOKA (pogledaj stranicu 45)
-  PRIMJERI INSTALACIJA (pogledaj stranicu 35)
-  REZERVNI DJELOVI (pogledaj stranicu 48)
-  ČIŠĆENJE (pogledaj stranicu 54)
-  ODRŽAVANJE (pogledaj stranicu 50)
-  Zamjena sita (pogledaj stranicu 50)
-  Zamjena rasvjetnih tijela (pogledaj stranicu 53)
-  elektroinstalater
-  priključak na dovod vode DN20 (Topla voda)
-  priključak na dovod vode DN20 (Hladna voda)
-  Protok vode mora biti veći od 50 l/min.
-  Odvod
-  Otvorite dotok vode
-  Zatvorite vodu
-  Neophodne dvije radne snage
-  Upozorenje na opasnost od vrele površine!
-  Nosite zaštitne rukavice
-  Nosite zaštitne naočale
-  prirodna spužva
-  Sredstvo za uklanjanje kamenca (na bazi limunske kiseline)
-  Izbjegavajte kontakt s očima i kožom. U slučaju kontakta s očima, temeljito isperite s dosta vode.
-  Struja uklj./isklj.



### ⚠ GÜVENLİK UYARILARI

- ⚠ Montaj esnasında ezilme ve kesilme gibi yaralanmaları önlemek için eldiven kullanılmalıdır.
- ⚠ Ürün yalnızca banyo, hijyen ve beden temizliği amaçları doğrultusunda kullanılabilir.
- ⚠ Bedensel, ruhsal ve/veya sensörük engelli çocuk ve yetişkinler gözetimsiz olarak duş sistemini kullanmamalıdır. Alkol veya uyuşturucu etkisinde olanlar duş sistemini kullanmamalıdır.
- ⚠ Püskürtme başlıklarının hassas organlara teması (örn. gözler) önlenmelidir. Püskürtücü ile beden arasında yeterli mesafe bırakılmalıdır.
- ⚠ Sıcak ve soğuk su bağlantıları arasında büyük basınç farklılıkları varsa, bu basınç farklılıklarının dengelenmesi gerekir.

### ELEKTRİK BAĞLANTISI

- ⚠ Elektrik bağlantısı sadece bir elektrik teknisyeni tarafından yapılmalıdır!
- ⚠ Gerilim beslemesini 100-240V/N/PE/50-60Hz (uzunluk: 1 m) önceden kurun.
- ⚠ Emniyete alma,  $\leq 30$  mA ölçüm farkı akımı olan bir hatalı akım koruma tertibatı (RCD/FI) üzerinden gerçekleştirilmelidir.
- ⚠ Ürün, yapı taraflı mevcut bir potansiyel dengelemesine (PA) 4 mm<sup>2</sup> bağlanmalıdır.

### ELEKTRONİK MONTAJCISI

- ⚠ Kurulum ve kontrol çalışmaları, VDE 0100 Bölüm 701, IEC 60364-6 ve IEC 60364-7-701'i ve EN 60335-2-105'i dikkate almak suretiyle, elektronik konusunda uzman yetkili bir kişi tarafından gerçekleştirilmelidir.
- ⚠ Şebeke bağlantı hattı çift izole  biçimde bağlantı utusuna yerleştirilmelidir.

### MONTAJ AÇIKLAMALARI



- / Montaj işleminden önce ürün nakliye hasarları yönünden kontrol edilmelidir. Montaj işleminden sonra nakliye veya yüzey hasarları için sorumluluk üstlenilmemektedir.
- / Boruların ve armatürün montajı, yıkanması ve kontrolü geçerli normlara göre yapılmalıdır.
- / Ülkelerde geçerli kurulum yönetmeliklerine riayet edilmelidir.
- / Ürünün yetkili uzman personel tarafından montajı yapılırken, sabitleme yüzeyinin sabitleme planının tüm alanında bulunduğu (derz veya fayans kayması olmamalıdır), duvar yapısının ürünün montajı için uygun olduğuna ve zayıf noktaları bulunmadığına dikkat edilmelidir.
- / Delik açarken elektrik ve su hatlarına dikkat!
- / Çıkış kapasitesi yeterli miktarda boyutlandırılmış olmalıdır.
- / Su püskürtücü yalnızca sıhhi armatür veya kapatma vanasından sonra bağlanabilir.

### TEKNİK BİLGİLER

Bataryadan önceki işletme basıncı:	azami 0,6 MPa
Tavsiye edilen işletme basıncı:	0,25 - 0,5 MPa
	(1 MPa = 10 bar = 147 PSI)
Sıcak su sıcaklığı:	azami 60°C
Tavsiye edilen su ısısı:	42°C
Güvenlik blokajı:	40°C
<b>Uyarı: Bu sıcaklığın aşılması, yanmalara neden olabilir!</b>	
Termik dezenfeksiyon:	azami 70°C/4 dak
Nominal gerilim:	100-240V AC 50-60Hz
Nominal giriş:	18 W
Lambalar 4 x LED:	12V DC SELV 4 W
Aydınlatma maddesi kısılamaz.	
Koruma sınıfı:	II
Koruma türü:	IPX5
Shower Heaven 970	
Ağırlık (ambalajlı)	47,9 kg
Shower Heaven 720	
Ağırlık (ambalajsız)	
	28,36 kg

Ürün sadece şebeke suyu için tasarlanmıştır!

### SİMGE AÇIKLAMASI

-  Asetik asit içeren silikon kullanmayın!
-  ÖLÇÜLERİ (bakınız sayfa 46)
-  AKIŞ DİYAGRAMI (bakınız sayfa 45)
-  MONTAJ ÖRNEĞİ (bakınız sayfa 35)
-  YEDEK PARÇALAR (bakınız sayfa 48)
-  TEMİZLEME (bakınız sayfa 54)
-  BAKIM (bakınız sayfa 50)
-  Eleklere değiştirme (bakınız sayfa 50)
-  Ampul değiştirme (bakınız sayfa 53)
-  Elektronik montajcısı
-  Su bağlantısı DN20 (Sıcak su)
-  Su bağlantısı DN20 (Soğuk su)
-  Akış kapasitesi 50 l/dak üzerinde olmalıdır.
-  Akış
-  Suyu açın
-  Suyu kesin
-  İki kişi gereklidir
-  Sıcak yüzeye karşı uyarı!
-  Koruyucu eldiven kullanın
-  Göz koruyucu kullanın
-  Doğal Sünger
-  Kireç sökücü (Limon asidi temeli)
-  Gözlere ve cilde temasından kaçının. Eğer ürün gözlerle buluşursa, gözlerinizi su ile iyice yıkayın.
-  Akım açık/kapalı



## INSTRUCȚIUNI DE SIGURANȚĂ

- ⚠ La montare utilizați mănuși pentru evitarea contuziunilor și tăierii mâinilor.
- ⚠ Produsul poate fi utilizat doar pentru spălarea, menținerea igienei și curățarea corpului.
- ⚠ Copiii și adulții cu dizabilități corporale, mintale și senzoriale nu pot utiliza sistemul de duș nesupravegheați. De asemenea este interzisă utilizarea sistemului de duș de către persoane, care se află sub influența alcoolului sau a drogurilor.
- ⚠ Evitați contactul jetului de apă cu părțile de corp sensibile (de ex. ochii). Țineți dușul la o distanță corespunzătoare de corp.
- ⚠ Diferențele de presiune mari între alimentarea cu apă rece și apă caldă trebuie echilibrate.

## CONEXIUNE ELECTRICĂ

- ⚠ Racordarea la rețeaua electrică poate fi efectuată numai de către un tehnician electronist specializat!
- ⚠ Preinstalați 100-240V/N/PE/50-60Hz (lungime: 1 m) cablul de alimentare cu curent.
- ⚠ Instalația trebuie asigurată printr-un dispozitiv de protecție împotriva curentului rezidual (RCD/FI) pentru curent rezidual măsurat de  $\leq 30$  mA.
- ⚠ Produsul trebuie conectat la un egalizator de potențial la fața locului (PA) 4 mm<sup>2</sup>.

## ELECTRICIAN

- ⚠ Lucrările de instalare și de verificare trebuie efectuate de către electricieni specializați, ținând cont de VDE 0100 Partea 701, IEC 60364-6 și IEC 60364-7-701, cât și EN 60335-2-105.
- ⚠ Cablul de alimentare de la rețea trebuie introdus dublu izolat  în cutia de conexiuni.

## INSTRUCȚIUNI DE MONTARE

- / Înainte de instalare verificați, dacă produsul prezintă deteriorări de transport. După instalare garanția nu acoperă deteriorările de transport și cele de suprafață.
- / Conductele și bateriile trebuie montate, spălate și verificate conform normelor în vigoare.
- / Respectați reglementările referitoare la instalare valabile în țara respectivă.
- / La montarea produsului de către un personal calificat se va avea grijă ca suprafața de fixare să fie plană pe toată aria de fixare (fără proeminențe ale rosturilor sau îmbinări între plăcile de faianță) și ca structura peretelui să fie corespunzătoare pentru fixarea produsului, să nu prezinte locuri cu rezistență redusă.
- / La efectuarea lucrărilor de găurire fiți atenți la conductele de apă și cablurile electrice!
- / Debitul de golire trebuie să fie suficient de mare.
- / Dușul poate fi instalat doar după un ventil de închidere sau o armătură sanitară.

## DATE TEHNICE

Presiune de funcționare înainte de baterie: max. 0,6 MPa  
 Presiune de funcționare recomandată: 0,25 - 0,5 MPa  
 (1 MPa = 10 bar = 147 PSI)

Temperatura apei calde: max. 60°C  
 Temperatura recomandată a apei calde: 42°C  
 Blocaj de siguranță: 40°C

Atenție: depășirea acestei temperaturi poate cauza arsuri!

Dezinfecție termică: max. 70°C / 4 min  
 Tensiune nominală: 100-240V AC 50-60Hz  
 Putere nominală: 18 W  
 Lămpi 4 x LED: 12V DC SELV 4 W

Intensitatea luminii nu este reglabilă.

























Clasă de protecție: II  
 Clasă de protecție: IPX5

Shower Heaven 970  
 Greutate (cu ambalaj) 47,9 kg

Shower Heaven 720  
 Greutate (fără ambalaj) 28,36 kg

Produsul este destinat exclusiv pentru apă potabilă.

## DESCRIEREA SIMBOLURILOR

-  Nu utilizați silicon cu conținut de acid acetic
-  DIMENSIUNI (vezi pag. 46)
-  DIAGRAMA DE DEBIT (vezi pag. 45)
-  EXEMPLE DE MONTARE (vezi pag. 35)
-  PIESE DE SCHIMB (vezi pag. 48)
-  CURĂȚARE (vezi pag. 54)
-  ÎNTREȚINERE (vezi pag. 50)
-  Înlocuirea sitelor (vezi pag. 50)
-  Înlocuirea luminii (vezi pag. 53)
-  Electrician
-  Racord de apă DN20 (Apă caldă)
-  Racord de apă DN20 (Apă rece)
-  Capacitatea de evacuare trebuie să fie mai mare de 50 l/min.
-  Deversor
-  Se introduce apa
-  Opreți alimentarea cu apă
-  Pentru aceste lucrări se necesită două persoane
-  Atenție la suprafața fierbinte!
-  Purtați mănuși de protecție
-  Purtați ochelari de protecție
-  Burete natural
-  Soluție de decalcifiere (bază de acid citric)
-  Evitați contactul cu ochii și cu pielea. În cazul în care produsul ajunge în contact cu ochii, clătiți bine cu apă.
-  Curent pornit/oprit

## ⚠ ΥΠΟΔΕΙΞΕΙΣ ΑΣΦΑΛΕΙΑΣ

- ⚠ Για να αποφύγετε τραυματισμούς κατά τη συναρμολόγηση πρέπει να φοράτε γάντια.
- ⚠ Το προϊόν επιτρέπεται να χρησιμοποιείται μόνο σαν μέσο λουτρού, υγιεινής και καθαρισμού του σώματος.
- ⚠ Παιδιά ή ενήλικες με μειωμένες σωματικές, διανοητικές και/ή αισθητήριες ανεπάρκειες δεν επιτρέπεται να χρησιμοποιούν το προϊόν χωρίς επιτήρηση. Άτομα υπό την επήρεια οινοπνεύματος ή ναρκωτικών δεν επιτρέπεται να χρησιμοποιούν σε καμία περίπτωση το προϊόν.
- ⚠ Η επαφή δέσμης νερού του ντους με ευαίσθητες περιοχές του σώματος (π.χ. μάτια) πρέπει να αποφεύγεται. Διατηρείτε επαρκή απόσταση ανάμεσα στο ντους και το σώμα.
- ⚠ Οι διαφορές της πίεσης μεταξύ της σύνδεσης κρύου και ζεστού νερού θα πρέπει να αντισταθμίζονται.

## ΗΛΕΚΤΡΙΚΗ ΠΑΡΟΧΗ

- ⚠ Η ηλεκτρική εγκατάσταση επιτρέπεται να πραγματοποιηθεί μόνο από εξειδικευμένο ηλεκτρολόγο!
- ⚠ Παροχή ρεύματος 100-240V/N/PE/50-60Hz (μήκος: 1 μέτρα) προ-εγκατάσταση.
- ⚠ Η ασφάλιση θα πρέπει να πραγματοποιείται μέσω διάταξης προστασίας ρεύματος διαρροής (RCD/FI) με παραμένον ρεύμα  $\leq 30$  mA.
- ⚠ Το προϊόν πρέπει να συνδεθεί με μία ισοδυναμική σύνδεση (PA) 4 mm<sup>2</sup> που έχει προεγκατασταθεί από τον πελάτη.

## ΗΛΕΚΤΡΟΛΟΓΟΣ ΕΓΚΑΤΑΣΤΑΣΗΣ

- ⚠ Οι εργασίες εγκατάστασης και ελέγχου πρέπει να διενεργούνται από έναν εγκεκριμένο ειδικό ηλεκτρολόγο, λαμβάνοντας υπόψη τις οδηγίες VDE 0100 Μέρος 701, IEC 60364-6 και IEC 60364-7-701 καθώς και το EN 60335-2-105.
- ⚠ Το καλώδιο σύνδεσης πρέπει να εισαχθεί με διπλή μόνωση  στο κουτί σύνδεσης.

## ΟΔΗΓΙΕΣ ΣΥΝΑΡΜΟΛΟΓΗΣΗΣ

- / Πριν τη συναρμολόγηση πρέπει να εξεταστεί το προϊόν για ζημιές μεταφοράς. Μετά την εγκατάσταση δεν αναγνωρίζονται ζημιές από τη μεταφορά ή επιφανειακές ζημιές.
- / Οι σωλήνες και η μπαταρία πρέπει να τοποθετηθούν σύμφωνα με τα ισχύοντα πρότυπα, να τεθούν υπό πίεση και να δοκιμαστούν.
- / Θα πρέπει να τηρούνται οι οδηγίες εγκατάστασης που ισχύουν σε κάθε κράτος.
- / Κατά τη συναρμολόγηση του προϊόντος από ειδικό προσωπικό θα πρέπει να ελέγχεται με ιδιαίτερη προσοχή η επιφάνεια στερέωσης, αν είναι επίπεδη σε όλη της την επιφάνεια (δεν πρέπει να εξέχουν αρμοί ή πλακάκια), αν η υποδομή του τοίχου είναι κατάλληλη για τη στερέωση του προϊόντος και αν παρουσιάζει ασθενή σημεία.
- / Προσοχή όταν τρυπάτε πάνω από σωλήνες ηλεκτρικού ή νερού!
- / Η κατανάλωση νερού πρέπει να έχει επαρκείς διαστάσεις.
- / Το ντους επιτρέπεται να συνδέεται μόνο αφού προηγηθεί στο κύκλωμα μία βαλβίδα διακοπής ή μπαταρία.

## ΤΕΧΝΙΚΑ ΧΑΡΑΚΤΗΡΙΣΤΙΚΑ

Πίεση λειτουργίας προ της βάνας:	έως 0,6 MPa
Συνιστώμενη λειτουργία πίεσης:	0,25 - 0,5 MPa (1 MPa = 10 bar = 147 PSI)
Θερμοκρασία ζεστού νερού:	έως 60°C
Συνιστώμενη θερμοκρασία ζεστού νερού:	42°C
Ασφάλεια υπερθέρμανσης νερού	40°C

Προειδοποίηση: Υπέρβαση αυτής της θερμοκρασίας μπορεί να προκαλέσει εγκαύματα

Θερμική απολύμανση:	έως 70°C / 4 min
Ονομαστική τάση:	100-240V AC 50-60Hz
Ονομαστική ισχύς:	18 W
Φωτιστικά 4 x LED:	12V DC SELV 4 W
Το φωτιστικό δεν διαθέτει ροοστάτη.	
Κατηγορία προστασίας:	II
Είδος προστασίας:	IPX5

Shower Heaven 970  
Βάρος (με συσκευασία) 47,9 kg

Shower Heaven 720  
Βάρος (χωρίς συσκευασία) 28,36 kg

Το προϊόν έχει σχεδιαστεί αποκλειστικά για πόσιμο νερό!

## ΠΕΡΙΓΡΑΦΗ ΣΥΜΒΟΛΩΝ

-  Μην χρησιμοποιείτε σιλικόνη που περιέχει οξικό οξύ!
-  ΔΙΑΣΤΑΣΕΙΣ (βλ. Σελίδα 46)
-  ΔΙΑΓΡΑΜΜΑ ΡΟΗΣ (βλ. Σελίδα 45)
-  ΠΑΡΑΔΕΙΓΜΑΤΑ ΣΥΝΑΡΜΟΛΟΓΗΣΗΣ (βλ. Σελίδα 35)
-  ΑΝΤΑΛΛΑΚΤΙΚΑ (βλ. Σελίδα 48)
-  ΚΑΘΑΡΙΣΜΟΣ (βλ. Σελίδα 54)
-  ΣΥΝΤΗΡΗΣΗ (βλ. Σελίδα 50)
-  Αντικατάσταση φίλτρων (βλ. Σελίδα 50)
-  Αντικατάσταση φωτιστικού (βλ. Σελίδα 53)
-  Ηλεκτρολόγος εγκατάστασης
-  Παροχή νερού DN20 (Ζεστό νερό)
-  Παροχή νερού DN20 (Κρύο νερό)
-  Η αποχετευτική ικανότητα της βαλβίδας εκροής πρέπει να υπερβαίνει τα l/min.
-  Βαλβίδα εκροής
-  Ανοίξτε την παροχή του νερού
-  Κλείστε την παροχή νερού
-  Θα πρέπει να απασχοληθούν 2 τεχνίτες
-  Προειδοποίηση: καυτή επιφάνεια!
-  Φοράτε γάντια προστασίας χεριών
-  Φοράτε γυαλιά προστασίας ματιών
-  Φυσικός σπόγγος
-  Αποσκληρυντής νερού (με βάση το κιτρικό οξύ)
-  Αποφεύγετε την επαφή με τα μάτια και το δέρμα. Σε περίπτωση που έλθει το προϊόν σε επαφή με τα μάτια ξεπλύνετε καλά με νερό.
-  Ρεύμα on/off



## VARNOSTNA OPOZORILA

- ⚠ Pri montaži je treba nositi rokavice, da se preprečijo poškodbe zaradi zmečkanja ali urezov.
- ⚠ Ta izdelek se sme uporabljati le z namenom umivanja, vzdrževanja higiene in telesne nege.
- ⚠ Otroci kot tudi odrasle osebe z omejenimi telesnimi, duševnimi in/ali senzoričnimi sposobnostmi ne smejo nenadzorovano uporabljati tega izdelka. Osebe, ki so pod vplivom alkohola ali drog, tega izdelka ne smejo uporabljati.
- ⚠ Izogibati se je treba stiku prhalnega curka z občutljivimi deli telesa (npr. očmi). Med telesom in prho mora biti vedno zadosten razmik.
- ⚠ Velike razlike v tlaku med priključkom za mrzlo in priključkom za toplo vodo je potrebno izravnati.

## ELEKTRIČNI PRIKLJUČEK

- ⚠ Električno priključitev sme izvesti le elektrostrokovnjak!
- ⚠ Napajanje 100-240V/N/PE/50-60Hz (dolžina: 1 m) predhodno instalirajte.
- ⚠ Zaščita se mora izvesti preko zaščitnega tokovnega stikala (RCD/FI) z izračunanim diferenčnim tokom  $\leq 30$  mA.
- ⚠ Izdelek mora biti priključen na potencialno izravnavo (PA) 4 mm<sup>2</sup> na lokaciji.

## ELEKTROINŠTALATER

- ⚠ Instalacijo in preizkuse mora izvesti pooblaščen elektro strokovnjak, pri čemer mora upoštevati VDE 0100 Del 701, IEC 60364-6 in IEC 60364-7-701 ter EN 60335-2-105.
- ⚠ Omrežni priključni kabel je treba dvojno izoliran  vstaviti v priključno dozo.

## NAVODILA ZA MONTAŽO

- / Pred montažo je treba izdelek preveriti glede morebitnih transportnih poškodb. Po vgradnji transportne ali površinske poškodbe ne bodo več priznane.
- / Cevi in armaturo je treba montirati, izprati in preveriti po veljavnih standardih.
- / Upoštevati je treba pravilnike o inštalacijah, ki veljajo v posamezni državi.
- / Pri montaži tega proizvoda s strani kvalificiranega strokovnega osebja je treba paziti na to, da je pritrdilna ploskev na celotni površini za pritrditev gladka (brez izstopajočih fug ali zasekov ploščic), da je struktura stene primerna za montažo proizvoda in ne kaže šibkih mest.
- / Pri vrtanju bodite pozorni na električne vodnike in vodovodno napeljavo
- / Zmogljivost odtoka mora biti ustrezne velikosti.
- / Prha se sme priključiti le za zapornim ventilom ali sanitarno armaturo.

## TEHNIČNI PODATKI

Obratovalni tlak pred armaturo:	maks. 0,6 MPa
Priporočeni delovni tlak:	0,25 - 0,5 MPa
	(1 MPa = 10 bar = 147 PSI)
Temperatura tople vode:	maks. 60°C
Priporočena temperatura tople vode:	42°C
Varnostna blokada:	40°C

Opozorilo: prekoračitev te temperature lahko povzroči opekline!

Termična dezinfekcija:	maks. 70°C/4 min
Nazivna napetost:	100-240V AC 50-60Hz
Nazivna poraba:	18 W
Svetilke 4 x LED:	12V DC SELV 4 W
Svetilka nima možnosti uravnavanja zatemnitve.	
Razred zaščite:	II
Vrsta zaščite:	IPX5

Shower Heaven 970























Teža (z embalažo) 47,9 kg

Shower Heaven 720

Teža (brez embalaže) 28,36 kg

Proizvod je zasnovan izključno za sanitarno vodo!

## OPIS SIMBOLA

-  Ne smete uporabiti silikona, ki vsebuje ocatno kislino!
-  MERE (glejte stran 46)
-  DIAGRAM PRETOKA (glejte stran 45)
-  PRIMERI MONTAŽE (glejte stran 35)
-  REZERVNI DELI (glejte stran 48)
-  ČIŠČENJE (glejte stran 54)
-  VZDRŽEVANJE (glejte stran 50)
-  Zamenjava sit (glejte stran 50)
-  Zamenjava svetilke (glejte stran 53)
-  Elektroinštalater
-  Vodni priključek DN20 (Topla voda)
-  Vodni priključek DN20 (Mrzla voda)
-  Odtočna kapacitetamora znašati več kot 50 l/min.
-  Odtok
-  Odprite vodo
-  Zaprite vodo.
-  Potrebna sta dva delavca
-  Opozorilo pred vročo površino!
-  Nosite zaščitne rokavice
-  Nosite zaščito za oči
-  Naravna gobica
-  Odstranjevalec apnenca (na osnovi citronske kisline)
- Izogibajte se stiku z očmi in kožo. Če proizvod pride v oči, jih temeljito sperite z vodo.
-  Tok vklop/izklop

## △ OHUTUSJUHISED

- △ Kandke paigaldamisel muljumis- ja löikevigastuste vältimiseks kindaid.
- △ Toodet tohib kasutada ainult pesemis-, hügieeni- ja kehapuhastamisesmärkidel.
- △ Lapsed, samuti kehaliste, vaimsete või tajupiirangutega täiskasvanud ei tohi dušisüsteemi järelevalveta kasutada. Alkoholi või narkootikumide mõju all olevad isikud ei tohi dušisüsteemi kasutada.
- △ Duši veejoad ei tohi kokku puutuda tundlike kehaosadega (nt silmad). Jätke duši ja keha vahele piisav vahe.
- △ Kui külma ja kuumu vee ühenduste surve on väga erinev, tuleb need tasakaalustada.

## ELEKTRIÜHENDUS

- △ Elektriühenduse peab läbi viima väljaõppinud elektrik!
- △ Eelpaigaldage pingega varustamine 100-240V/N/PE/50-60Hz (pikkus: 1 m).
- △ Kaitse peab toimuma rikkevoolu kaitseeadisega (RCD/FI) nominaal-jääkvooluga ≤ 30 mA.
- △ Toode tuleb ühendada kohapeal olemasoleva potentsiaaliühtlustusega (PA) 4 mm<sup>2</sup>.

## ELEKTRIMONTÖÖR

- △ Paigaldustööd ja kontroll laske viia läbi sertifitseeritud spetsialistil vastavalt VDE 0100 osa 701, IEC 60364-6 ja IEC 60364-7-701 ning EN 60335-2-105 eeskirjadele.
- △ Võrgujuhe tuleb juhtida topeltisolatsiooniga  ühen use pistikupessa.

## PAIGALDAMISJUHISED

- / Enne paigaldamist tuleb toodet kontrollida transpordikahjustuste osas Pärast paigaldamist ei tunnustata enam transpordi- või pinnakahjustuste kaebuseid.
- / Voolikute ja segisti paigaldamisel, loputamisel ja kontrollimisel tuleb lähtuda kehtivatest normatiividest
- / Vastavas riigis kehtivaid paigalduseeskirju tuleb järgida.
- / Toote paigaldamisel kvalifitseeritud spetsialistide poolt tuleb jälgida, et kinnituspind oleks kogu ulatuses ühtlaselt tasane (mitte ühtki üleseisvat vuuki või kaldus kahhelkivi), seinä ülesehitus toote paigaldamiseks sobiv ja ilma nõrkade kohtadeta.
- / Arvestage puurimisel voolukaablite ja veejuhtmete asukohaga
- / Äravoolu jõudlus peab olema piisav.
- / Duši tohib ühendada ainult sulgurkraani või sanitaaramatuuri järele.

## TEHNILISED ANDMED

töörõhk süsteemis enne dušši:	maks. 0,6 MPa
Soovitav töörõhk:	0,25 - 0,5 MPa
	(1 MPa = 10 baari = 147 PSI)
Kuumu vee temperatuur:	maks. 60°C
Soovitav kuumu vee temperatuur:	42°C
Kaitseelikk:	40°C

Hoiatus: selle temperatuuri ületamisel võivad tekkida põletused!

Terminline desinfektsioon:	maks. 70°C / 4 min
Nimipinge:	100-240V AC 50-60Hz
Nimisisend:	18 W
Valgustid 4 x LED:	12V DC SELV 4 W
Valgustit ei saa hämardada.	
Kaitseklass:	II
Kaitseklass:	IPX5
Shower Heaven 970	
Kaal (koos pakendiga)	47,9 kg
Shower Heaven 720	
Kaal (ilma pakendita)	28,36 kg

Toode on ette nähtud eranditult joogivee jaoks!

## SÜMBOLITE KIRJELDUS

-  Ärge kasutage äädikhapet sisaldavat silikoonil
-  MÕÕTUDE (vt lk 46)
-  LÄBIVOOLUDIAGRAMM (vt lk 45)
-  PAIGALDUSE NÄITED (vt lk 35)
-  VARUOSAD (vt lk 48)
-  PUHASTAMINE (vt lk 54)
-  HOOLDUS (vt lk 50)
-  Sõela vahetamine (vt lk 50)
-  Lambi vahetamine (vt lk 53)
-  Elektrimontöör
-  Veeühendus DN20 (Soe vesi)
-  Veeühendus DN20 (Külm vesi)
-  Äravoolu jõudlus peab olema suurem kui 50 l/min.
-  Äravool
-  Keerake vesi lahti
-  Keerake vesi kinni
-  Vajab kahte töötajat
-  Kuum pealispind!
-  Kandke kaitsekindaid
-  Kandke kaitseprille
-  Looduslik svamm
-  Katlakivi eemaldaja (põhineb sidrunhappel)
-  Vältige kokkupuudet silmade ja nahaga. Kui toode satub silma, siis loputage silmi hoolikalt veega..
-  Elektrivool sees/väljas





## ⚠ DROŠĪBAS NORĀDES

- ⚠ Montāžas laikā, lai izvairītos no saspiedumiem un iegriezumiem, nepieciešams nēsāt cimdus.
- ⚠ Šo produktu drīkst izmantot tikai, lai mazgātos, higiēnai un ķermeņa tīrīšanai.
- ⚠ Bērni, kā arī pieaugušie ar fiziskiem, garīgiem un/vai sensoriskiem ierobežojumiem nedrīkst lietot šo produktu bez uzraudzības. Personas, kas atrodas alkohola vai narkotisko vielu iespaidā, nedrīkst lietot šo dušas sistēmu.
- ⚠ Nepieciešams izvairīties no dušas strūkļas tieša kontakta ar jutīgām ķermeņa daļām (piem., acīm). Nepieciešams ievērot pietiekošu attālumu starp dušu un ķermeni.
- ⚠ Jāizlīdzina spiediena atšķirības starp aukstā un karstā ūdens pievadiem.

## ELEKTROAPGĀDES PIESLĒGVIETA

- ⚠ Elektrisko pieslēgumu drīkst veikt tikai elektriķis!
- ⚠ Barošanas bloku 100-240V/N/PE/50-60Hz (garums: 1 m) instalēt iepriekš.
- ⚠ Jānodrošina noplūdes strāvas aizsargsistēma (RCD/FI) ar izmērīto strāvas starpību ≤ 30 mA.
- ⚠ Izstrādājums jāpieslēdz pasūtītāja paredzētajam potenciālu izlīdzinātājam (PA) 4 mm<sup>2</sup>.

## ELEKTROMONTIERIS

- ⚠ Instalācijas un pārbaudes darbus jāveic sertificētam speciālistam saskaņā ar DIN VDE 0100 701. d., IEC 60364-6, IEC 60364-7-701 un EN 60335-2-105.
- ⚠ Tikla pieslēgšanas vads jāievada pieslēgšanas rozetē  r dubultu izolāciju .

## NORĀDĪJUMI MONTĀŽAI

- / Pirms montāžas nepieciešams pārbaudīt, vai produktam transportēšanas laikā nav radušies bojājumi. Pēc iebūvēšanas bojājumi, kas radušies transportēšanas laikā, vai virsmas bojājumi netiek atzīti.
- / Cauruļvadi un armatūra ir jāuzstāda, jāizskalo un jāpārbauda saskaņā ar spēkā esošajiem standartiem.
- / Jāievēro attiecīgās valstis spēkā esošās montāžas prasības.
- / Kvalificētiem speciālistiem, montējot produktu, jāpiegriež vērība tam, lai piestiprināšanas virsma visā piestiprināšanas zonā ir gluda (nav fūgu vai fližu iecirtumu), sienas uzbūve ir piemērota produkta montāžai un tajā nav nestabilu vietu.
- / Urbjot pievērsiet uzmanību elektrības un ūdens vadiem!
- / Noplūdei jānodrošina pietiekama ūdens cauruļvade.
- / Dušu drīkst pieslēgt tikai aiz noslēgšanas vārsta vai sanitāras armatūras.

## TEHNISKIE DATI

Darba spiediens pirms jaucējkrāna:	maks. 0,6 MPa
leteicamais darba spiediens:	0,25 - 0,5 MPa
	(1 MPa = 10 bar = 147 PSI)
Karstā ūdens temperatūra:	maks. 60°C
leteicamā karstā ūdens temperatūra:	42°C
droša temperatūra	40°C

Brīdinājums: šīs temperatūras pārsniegšana var izraisīt applaucēšanos!

Termiskā dezinfekcija:	maks. 70°C/4 min
Nominālais spriegums:	100-240V AC 50-60Hz
nominālais patēriņš:	18 W
Gaismekļi 4 x LED:	12V DC SELV 4 W
Lampas spilgtums nav regulējams.	
Aizsardzības klase:	II
Aizsardzības līmenis:	IPX5

ShowerHeaven 970	
Svars (ar iesaiņojumu)	47,9 kg
ShowerHeaven 720	
Svars (bez iesaiņojuma)	28,36 kg

Izstrādājums ir paredzēts tikai dzeramajam ūdenim!

## SIMBOLU NOZĪME

-  Neizmantojot silikonu, kas satur etiķskābi!
-  IZMĒRUS (skat. lpp. 46)
-  CAURPLŪDES DIAGRAMMA (skat. lpp. 45)
-  MONTĀŽAS PIEMĒRI (skat. lpp. 35)
-  REZERVES DAĻAS (skat. lpp. 48)
-  TĪRĪŠANA (skat. lpp. 54)
-  APKOPE (skat. lpp. 50)
- Sietu nomaiņa (skat. lpp. 50)
- Argaismes ķermeņa nomaiņa (skat. lpp. 53)
-  Elektromontieris
-  Ūdensvada pieslēgvietā DN20 (Siltais ūdens)
-  Ūdensvada pieslēgvietā DN20 (Aukstais ūdens)
-  Noteces veiktspējai jābūt vairāk nekā 50 l/min.
-  Notece
-  Atgrieziet ūdeni
-  Noslēgt ūdeni
-  Nepieciešami divi darbinieki
-  Brīdinājums par karstu virsmu!
-  Valkāt aizsargcimdus
-  Valkāt acu aizsargus
-  Dabīgais sūklis
-  Atkaļķotājs (uz citronskābes bāzes)
- Novērst nokļūšanu acīs un uz ādas. Ja produkts iekļūst acīs, tās kārtīgi jāskalo ar ūdeni.
-  Strāva ieslēgta/izslēgta

## ⚠ SIGURNOSNE NAPOMENE

- ⚠ Prilikom montaže se radi sprečavanja prignječanja i posekotina moraju nositi rukavice.
- ⚠ Proizvod sme da se koristi samo za kupanje, tuširanje i ličnu higijenu.
- ⚠ Deca, kao i telesno, mentalno i/ili senzorno hendikepirane odrasle osobe ne smeju da koriste proizvod bez nadzora. Osobe koje su pod uticajem alkohola ili droga ne smeju da koriste proizvod.
- ⚠ Mora se izbegavati kontakt mlaza iz tuša sa osetljivim delovima tela (npr. očima). Telo korisnika mora biti na dovoljnom odstojanju od tuša.
- ⚠ Velika razlika u pritisku između vruće i hladne vode mora biti izbalansirana.

## ELEKTRIČNI PRIKLJUČAK

- ⚠ Električnu mrežu sme priključiti samo ovlašćeni električar!
- ⚠ Prethodno priključite naponsko napajanje 100-240V/N/PE/50-60Hz (dužina: 1 m).
- ⚠ Vod se mora osigurati nadstrujnom zaštitnom sklopkom (RCD/FI) s nazivnom diferencijalnom strujom  $\leq 30$  mA.
- ⚠ Proizvod mora da se priključi na postojeće izjednačenje potencijala (PA) 4 mm<sup>2</sup>.

## ELEKTROINSTALATER

- ⚠ Instalaciju i ispitivanje smeju obavljati isključivo sertifikovani električari uz uvažavanje odredaba VDE 0100 deo 701, IEC 60364-6 i IEC 60364-7-701 kao i EN 60335-2-105.
- ⚠ Strujni priključni kabl mora da se dvostruko izoliran  uvede u utičnicu.

## INSTRUKCIJE ZA MONTAŽU

- / Pre montaže se mora proveriti da li je proizvod oštećen pri transportu. Nakon ugradnje se ne priznaju nikakve reklamacije koje se odnose na površinska i transportna oštećenja.
- / Vodovi i armatura moraju biti postavljeni, isprani i testirani prema važećim normama.
- / Treba se pridržavati propisa koji u određenim zemljama važe za instalacije.
- / Kada proizvod montira kvalifikovano stručno osoblje treba paziti da čitava površina na koju se učvršćuje bude ravna (bez istaknutih fuga ili krivljenja pločica), da je zidna konstrukcija primerena montaži proizvoda i da nema slabih mesta.
- / Prilikom bušenja treba paziti na električne kablove i vodovodne cevi!
- / Mora se predvideti dovoljan kapacitet odvoda.
- / Tuš se sme priključivati samo iza ventila za zatvaranje ili iza sanitarne armature.

## TEHNIČKI PODACI

Radni pritisak ispred armature:	maks. 0,6 MPa
Preporučeni radni pritisak:	0,25 - 0,5 MPa (1 MPa = 10 bar = 147 PSI)
Temperatura vruće vode:	maks. 60°C
Preporučena temperatura vruće vode:	42°C
Sigurnosni prekid:	40°C

























Upozorenje: Prekoračenje ove temperature može da izazove opekotine!

Termička dezinfekcija:	maks. 70°C / 4 min
Nominalni napon:	100-240V AC 50-60Hz
Nominalna potrošnja:	18 W
Svetiljke 4 x LED:	12V DC SELV 4 W
Sijalica nije prigušiva.	
Klasa zaštite:	II
Klasa zaštite:	IPX5

Shower Heaven 970	
Bruto težina	47,9 kg
Shower Heaven 720	
Neto težina	28,36 kg

Proizvod je koncipiran isključivo za pijaću vodu!

## OPIS SIMBOLA

-  Nemojte koristiti silikon koji sadrži sirćetnu kiselinu!
-  MERE (vidi stranu 46)
-  DIJAGRAM PROTOKA (vidi stranu 45)
-  PRIMERI MONTAŽE (vidi stranu 35)
-  REZERVNI DELOVI (vidi stranu 48)
-  ČIŠĆENJE (vidi stranu 54)
-  ODRŽAVANJE (vidi stranu 50)
-  Zamena mrežica (vidi stranu 50)
-  Zamena svetiljki (vidi stranu 53)
-  elektroinstalater
-  priključak za vodu DN20 (Topla voda)
-  priključak za vodu DN20 (Hladna voda)
-  Kapacitet odvoda mora biti veći od 50 l/min.
-  Ispust
-  Otvorite dotok vode
-  Zatvorite dotok vode
-  Potrebne su dve radne snage
-  Upozorenje na opasnost od vruće površine!
-  Nosite zaštitne rukavice
-  Nosite zaštitne naočare
-  prirodni sunder
-  Sredstvo za uklanjanje kamenca (na bazi limunske kiseline)
-  Izbegavajte kontakt sa očima i kožom. U slučaju kontakta sa očima, dobro isperite sa dosta vode.
-  Struja uklj./isklj.

## ⚠ SIKKERHETSHENVISNINGER

- ⚠ Bruk hansker under montasjen for å unngå klem- og kuttskader.
- ⚠ Produktet skal kun brukes for bade-, hygiene- og kroppshygiene.
- ⚠ Barn og voksne med fysiske og psykiske og/eller sensoriske handicap skal ikke bruke dusjsystemet uten oppsyn. Personer som er påvirket av alkohol eller narkotika skal ikke bruke dusjsystemet.
- ⚠ Dusjstrålen skal ikke komme i kontakt med ømfintlige kroppsdeler (f.eks. øynene). Overhold en tilstrekkelig avstand mellom dusjen og kroppen.
- ⚠ Store trykkdifferanser mellom kaldt- og varmtvannstilkoblinger skal utlignes.

## EL-TILKOBLINGER

- ⚠ El-tilkoblinger skal kun utføres av el-fagfolk!
- ⚠ Installer strømforsyning 100-240V/N/PE/50-60Hz lengde: 1 m) på forhånd.
- ⚠ Installasjonen skal sikres ved hjelp av en jordfeilbryter (RCD/FI) dimensjonert for en reststrøm på  $\leq 30$  mA.
- ⚠ Produktet må tilkobles en 4 mm<sup>2</sup> potensialutjevning (PA).

## EL-INSTALLATØR

- ⚠ Installasjons- og kontrollarbeid skal utføres av en godkjent el-fagbedrift som overholder direktiv VDE 0100 del 701, IEC 60364-6 og IEC 60364-7-70101. samt EN 60335-2-105.
- ⚠ Strømforsyningsledningen må være dobbelt isolert , og settes inn i stikkontakten.

## MONTAGEHENVISNINGER

- / Før montasjen skal produktet sjekkes for transportskader. Etter monteringen aksepteres ikke noen transport- eller overflateskader.
- / Ledningene og armaturen skal monteres, spyles og sjekkes iht. de gyldige normer.
- / Gjeldende retningslinjer for rørleggerarbeid i de enkelte land skal følges.
- / Under monteringen av produktet gjort av kvalifisert fagperson, skal man påse at monteringsoverflaten på hele festeområdet er plant (ingen utstikkende fuger eller flisekanter), at veggoppbyggingen egner seg for produktmontasjen og ikke viser svake punkter.
- / Ved boring skal det passes på strøm- og vannledninger!
- / Utløpsytelsen skal være tilstrekkelig dimensjonert.
- / Dusjen skal kun monteres etter en avstengingsventil eller etter sanitærarmatur.

## TEKNISKE DATA

Driftstrykk før armatur:	maks. 0,6 MPa
Anbefalt driftstrykk:	0,25 - 0,5 MPa
	(1 MPa = 10 bar = 147 PSI)
Varmtvannstemperatur	maks. 60°C
Anbefalt temperatur for varmt vann	42°C
Sikkerhetssperre	40°C

Varselshenvisning: Overskridelse av denne temperaturen kan medføre forbrenninger!

Termisk desinfisering:	maks. 70°C / 4 min
Nominell spenning:	100-240V AC 50-60Hz
nominell inngang:	18 W
Lamper 4 x LED:	12V DC SELV 4 W
Lyspæren kan ikke dimmes.	
Beskyttelsesklasse:	II
Beskyttelsesklasse:	IPX5
ShowerHeaven 970	
Vekt (med emballasje)	47,9 kg
ShowerHeaven 720	
Vekt (uten emballasje)	28,36 kg

Produktet er utelukkende designet for drikkevann!

## SYMBOLBESKRIVELSE

-  Ikke bruk silikon som inneholder eddiksyre!
-  MÅL (se side 46)
-  GJENNOMSTRØMNINGSDIAGRAM (se side 45)
-  MONTASJE-EKSEMPEL (se side 35)
-  SERVICEDELER (se side 48)
-  RENGJØRING (se side 54)
-  VEDLIKEHOLD (se side 50)
- Bytte sil (se side 50)
- Bytte lysmiddel (se side 53)
-  El-installatør
-  Vanntilkobling DN20 (Varmtvann)
-  Vanntilkobling DN20 (Kaldtvann)
-  Avløp ytelse skal være mer enn 50 l/min.
-  Avløp
-  Vann settes på
-  Slå av vann
-  Nødvendig med to arbeidskrefter
-  Varsel pga. het overflate!
-  Bruk vernehansker
-  Bruk vernebriller
-  Natursvamp
-  Avkalker (sitronsyrebasert)
- Unngå øye- og hudkontakt. Hvis produktet skulle komme i kontakt med øynene, skyl dem grundig med vann.
-  Strøm på/av

## ▲ УКАЗАНИЯ ЗА БЕЗОПАСНОСТ

- ▲ При монтажа трябва да се носят ръкавици, за да се избегнат наранявания поради притискане или порязване.
- ▲ Позволено е използването на продукта само за къпане, хигиена и цели на почистване на тялото.
- ▲ Не е позволено деца, както и възрастни с физически, умствени и/или сензорни ограничения да използват продукта без надзор. Не е позволено използването на системата на продукта от лица, употребили алкохол или дрога.
- ▲ Трябва да се избягва контакта на струите на разпръсквателя с чувствителни части на тялото (напр. очите). Между разпръсквателя и тялото трябва да се спазва достатъчно разстояние.
- ▲ Големите разлики в налягането между изводите за студената и топлата вода трябва да се изравняват.

## СВЪРЗВАНЕ КЪМ ЕЛЕКТРИЧЕСТВОТО

- ▲ Съвързането към електричество се позволява само от електротехник!
- ▲ Захранването с напрежение 100-240V/N/PE/50-60Hz (дължина: 1 m) се инсталира предварително.
- ▲ Защитата трябва да се осъществи с предпазен шалтер за остатъчен ток (RCD/FI) с параметриран диференциален ток  $\leq 30$  mA.
- ▲ Продуктът трябва да бъде свързан към напично при инвеститора изравняване на потенциала (PA) 4 mm<sup>2</sup>.

## ЕЛЕКТРОМОНТЪОР

- ▲ Дейностите по инсталацията и инспекцията следва да бъдат изпълнявани от оторизиран електротехник при спазване на VDE 0100 Част 701, IEC 60364-6 и IEC 60364-7-701 както и на EN 60335-2-105.
- ▲ Кабелът за свързване към мрежата трябва да бъде вкаран в двойно изолиран в присъединителната кутия.

## УКАЗАНИЯ ЗА МОНТАЖ

- / Преди монтажа продуктът трябва да се провери за транспортни щети. След монтажа не се признават транспортни или повърхностни щети.
- / Тръбопроводите и арматурата трябва да се монтират, промият и проверят в съответствие с валидните норми.
- / Трябва да бъдат спазвани валидните в съответните страни предписания за инсталиране.
- / При монтаж на продукта от квалифицирани специалисти да се внимава за това, закрепващата повърхност в целия диапазон на закрепването да бъде равна (без излъкнали fugи или изместване на плочки), конструкцията на стената да е подходяща за монтаж на продукта и да няма слаби места.
- / При пробиването внимавайте за електро- и водопроводите!
- / Трябва да се изчисли достатъчна мощност на изтичане.
- / Разпръсквателят може да се свърже само след спиращ клапан или санитарна арматура.

## ТЕХНИЧЕСКИ ДАННИ

Работно налягане преди арматурата:	макс. 0,6 МПа
Препоръчително работно налягане:	0,25 - 0,5 МПа (1 МПа = 10 bar = 147 PSI)
Температура на горещата вода:	макс. 60°C
Препоръчителна температура на горещата вода:	42°C
Предпазна блокировка:	40°C

Предупредително указание: Надвишаването на температурата може да доведе до изгаряния!

Термична дезинфекция:	макс. 70°C/4 мин
Номинално напрежение:	100-240V AC 50-60Hz
Номинална консумируема мощност:	18 W
Лампи 4 x LED:	12V DC SELV 4 W

Яркостта на осветителното тяло не може да се регулира.

























Защитен клас:	II
Вид защита:	IPX5

ShowerHeaven 970	
Тегло (без опаковката)	47,9 kg

ShowerHeaven 720	
Тегло (с опаковката)	28,36 kg

Продуктът е разработен само за питейна вода!

## ОПИСАНИЕ НА СИМВОЛИТЕ

-  Не използвайте силикон, съдържащ оцетна киселина!
-  РАЗМЕРИ (вижте стр. 46)
-  ДИАГРАМА НА ПОТОКА (вижте стр. 45)
-  ПРИМЕРИ ЗА МОНТАЖ (вижте стр. 35)
-  СЕРВИЗНИ ЧАСТИ (вижте стр. 48)
-  ПОЧИСТВАНЕ (вижте стр. 54)
-  ПОДДРЪЖКА (вижте стр. 50)
-  Смяна на цедките (вижте стр. 50)
-  Смяна на осветителното тяло (вижте стр. 53)
-  Електромонтьор
-  Извод за вода DN20 (Топла вода)
-  Извод за вода DN20 (Студена вода)
-  Мощността на изтичане трябва да бъде повече от 50 л/мин.
-  Отвеждане
-  Включване на водата
-  Изключване на водата
-  За работа са необходими двама души
-  Предупреждение за гореща повърхност!
-  Носете защитни ръкавици
-  Носете защита за очите
-  Естествен сунгер
-  Препарат за почистване на варовик (на базата на лимонена киселина)
-  Избягвайте контакт с очите и кожата. Ако продуктът попадне в очите Ви, изплакнете ги добре с вода.
-  Електричество вкл./изкл

## UDHËZIME SIGURIE

- △ Për të evituar lëndimet e pickimeve ose të prerjeve gjatë procesit të montimit duhet që të vishni doreza.
- △ Produkti duhet të përdoret vetëm qëllimet e banjave, të higjienës dhe të larjes së trupit.
- △ Fëmijët dhe të rriturit me aftësi të kufizuara fizike, mendore dhe/ose ndijuese nuk duhet ta përdorin produktin pa qenë nën mbikëqyrje. Personat që janë nën ndikimin e drogave ose të alkoolit nuk duhet ta përdorin produktin.
- △ Kontakti i valëve të dushit me pjesët e ndjeshme të trupit (p.sh. me sytë) duhet që të shmanget. Midis dushit dhe trupit duhet që të mbahet një distancë e mjaftueshme.
- △ Ndryshimet e mëdha të presionit mes lidhjeve të ujit të ftohtë dhe atij të ngrohtë duhen ekuilibruar.

## LIDHJA ME RRJETIN ELEKTRIK

- △ Lidhjet elektrike mund të bëhen vetëm nga electricisti i specializuar.
- △ Instaloni më parë furnizimin me energji elektrike 100-240V/N/PE/50-60Hz (Gjatësia: 1 m).
- △ Sigurimi duhet të kryhet nëpërmjet një pajisjeje mbrojtëse kundër rrjedhjes së rrymës (RCD/FI) me një vlerësim të rrymës diferenciale  $\leq 30\text{mA}$ .
- △ Produkti duhet të lidhet në një barazues ekzistues potenciale (PA) 4 mm<sup>2</sup>.

## ELEKTRICISTI

- △ Punimet e instalimit dhe të kontrollit duhet të realizohen nga një electricist i autorizuar duke marrë parasysh VDE 0100 Pjesa 701, IEC 60364-6 dhe IEC 60364-7-701 si dhe EN 60335-2-105.
- △ Linja e lidhjes me rrjetin elektrik duhet të jetë dyfsh e izoluar  e futur në kutinë e lidhjes.

## UDHËZIME PËR MONTIMIN

- / Përpara montimit duhet që produkti të kontrollohet për dëmtime nga transporti. Pas instalimit nuk do të njihet asnjë dëmtim nga transporti ose dëmtim i sipërfaqes.
- / Tubacionet dhe rubinetet duhet që të montohen, të shpëlahen dhe të kontrollohen sipas standardeve në fuqi
- / Duhet të respektohen linjat udhëzuese të instalimit, të vlefshme për vendet respektive.
- / Gjatë montimit të produktit nga teknikat e specializuara duhet mbajtur parasysh që sipërfaqja e montimit gjendet brenda zonës së përgjithshme të planit të montimit (nuk ka vendbashkime të dala ose mospërputhje të pllakave), që struktura e murit është e përshtatshme për montimin e produktit dhe që nuk paraqet asnjë pikë të dobët.
- / Gjatë shpimit bëni kujdes për të gjitha linjat elektrike dhe tubacionet e ujit!
- / Kapaciteti i rrjedhjes duhet dimensionuar në mënyrë të mjaftueshme.
- / Dushi duhet të jetë i lidhur/montuar vetëm pas një ventili (valvule) bllokuese ose pajisjeje sanitare.

## TË DHËNA TEKNIKE

Shtypja para armaturës:	maks. 0,6 MPa
Presioni i rekomanduar:	0,25 - 0,5 MPa (1 MPa = 10 bar = 147 PSI)
Temperatura e ujit të ngrohtë	maks. 60°C
Temperatura e rekomanduar e ujit të ngrohtë:	42°C
Bllokada e sigurisë	40°C

Paralajmërim Tejkalimi i kësaj temperature mund të shkaktojë djegie!

Dezinfektim Termik:	maks. 70°C/4 min
Tensioni nominal:	100-240V AC 50-60Hz
Konsumi i punës:	18 W
Ndriçuesit 4 x LED:	12V DC SELV 4 W

Mjeti ndriçues nuk është i kontrollueshëm.

























Klasa e mbrojtjes:	II
Lloji i mbrojtjes:	IPX5

ShowerHeaven 970	
Pesha (me ambalazh)	47,9 kg

ShowerHeaven 720	
Pesha (pa ambalazh)	28,36 kg

Produkti është projektuar ekskluzivisht për ujë të pijshëm!

## PËRSHKRIMI I SIMBOLIT

-  Mos përdorni silikon që në përbërje ka acid acetik.
-  PËRMASAT (shih faqen 46)
-  DIAGRAMI I QARKULLIMIT (shih faqen 45)
-  SHEMBUJ TË MONTIMIT (shih faqen 35)
-  PJESËT E SERVISIT (shih faqen 48)
-  PASTRIMI (shih faqen 54)
-  MIRËMBAJTJA (shih faqen 50)
-  Ndërrimi i filtrave (shih faqen 50)
-  Ndërrimi i llambës (shih faqen 53)
-  Electricisti
-  Lidhja me rrjetin e ujit DN20 (Uji i ngrohtë)
-  Lidhja me rrjetin e ujit DN20 (Uji i ftohtë)
-  Kapaciteti i shkarkimit duhet të jetë më shumë se 50 l/minutë.
-  Shkarkimi
-  Hapni ujin
-  Mbyllni ujin.
-  Për realizimin nevojiten dy persona
-  Paralajmërimi për sipërfaqen e nxehtë!
-  Vendosi doreza mbrojtëse
-  Vendosi mbrojtëse për sytë
-  Sfungjer natyral
-  Largues bigorri (me bazë acidi citrik)
-  Shmangni kontaktin me sytë dhe lëkurën. Nëse produkti bie në kontakt me sytë, shpëlahuni ato mirë me ujë të bollshëm.
-  Korrenti kyçur/shkyçur



## وصف الرمز

- هام! لا تستخدم السليكون الذي يحتوي على أحماض!  
أبعاد (راجع صفحة 46)
- رسم للصراف (راجع صفحة 45)
- مثال على التركيب (راجع صفحة 35)
- قطع الغيار (راجع صفحة 48)
- التنظيف (راجع صفحة 54)
- الصيانة (راجع صفحة 50)
- إستبدال المصفاة (راجع صفحة 50)  
إستبدال وسيلة الإضاءة (راجع صفحة 53)
- مختص تركيب إلكترونيات
- توصيلة مياه DN20 (ماء دافئ)
- توصيلة مياه DN20 (ماء بارد)
- يجب أن تكون قدرة الصرف أكبر من 50 لتر/دقيقة  
تصريف Rain drain
- افتح خلط المياه
- قم بإيقاف المياه
- يجب توفر عاملين
- سطح ساخن!
- يجب ارتداء قفازات الحماية
- يجب ارتداء تجهيزات حماية العين
- إسفنجة طبيعية
- مزيل تكلس (بحامض الليمون)
- يجب تجنب ملامسة المنتج للعين والجلد. وفي حالة ملامسة المنتج للعين يجب غسلها جيداً بالماء.
- تثاقف الكهرباء

## تنبيهات الأمان

- يجب ارتداء قفازات لليد أثناء التركيب لتجنب حدوث أخطار الإنحشار أو الجروح
- لا يجب استخدام المنتج إلا في أغراض الاستحمام والأغراض الصحية وأغراض تنظيف الجسم
- لا يسمح لأي أطفال أو أفراد بالغين يعانون من إعاقات بدنية أو ذهنية أو حسية أو يعانون من جميع هذه الإعاقات باستخدام المنتج إلا تحت إشراف آخرين. كما أنه لا يسمح لأي شخص تحت تأثير تناول الكحول أو المخدرات باستخدام نظام الدش.
- يجب تجنب حدوث اتصال مباشر بين الماء الخارج من رأس الدش وبين أجزاء الجسم الحساسة (مثل العينين). يجب وجود مسافة كافية بين رأس الدش والجسم
- يجب أن يكون تيار الماء الساخن والماء البارد متعادلين في الضغط.

## توصيلة كهربائية

- لا يجوز القيام بالتوصيلات الكهربائية إلا عن طريق فني كهرباء متخصص!
- يتم التركيب المسبق لخطوط إمدادات الطاقة 60Hz-240V/NPE/50-100 (طول: 1م).
- يتم التأمن من خلال تجهيزة حماية ضد اختلاف التيار (RCD/FI) عند اختلاف التيار لأقل من أو يساوي 30 مللي أمبير.
- يجب أن يكون المنتج موصلاً بموصل ربط متساوي الجهد (PA) متاحاً في الموقع 4مباسكال/ميلي متر مربع

## مختص تركيب إلكترونيات

- يتعين القيام بكافة أعمال التركيب والفحص من قبل فني كهرباء معتمد مع الأخذ في الاعتبار الالتزام بالمعيار VDE 0100 الجزء 701 و IEC 60364 و IEC 60364-7-105-2-EN 60335.

- يجب وضع كابل التيار الكهربائي في المقبس ويكون معزولاً عزلاً مزدوجاً.

## تعليمات التركيب

- قبل القيام بعملية التركيب، يجب فحص المنتج للتأكد من خلوه من أية تلفيات ناتجة عن النقل بعد القيام بعملية التركيب، لن يتم الاعتراف بوجود أية تلفيات سطحية أو تلفيات ناتجة عن عملية النقل.
- يجب تركيب وغسيل واختيار التوصيلات وخلطات المياه طبقاً للمعايير السارية.
- يجب مراعاة القواعد الخاصة بالتركيب وأعمال السباكة وفقاً للوائح الخاصة بكل بلد.
- عند التركيب بواسطة عمال تركيب متخصصين يجب الإنتباه إلى أن مساحة التثبيت في مكان التركيب بوجه عام مسطحة (لا توجد روابط أو فروق للربط بين البلاطات). لذا يجب التأكد من أن الحائط الذي سيتم تركيب المنتج عليه صالح لذلك وأنه لا يوجد به نقاط ضعف.
- يجب الحذر عند الثقوب فوق وصلات كهرباء أو مياه!
- يجب أن يكون الأداء من حيث حجز الفضلات ذا حجم مناسب.
- يسمح بتوصيل الدش فقط بعد صمام حبس الماء أو بعد خلط الماء.

## المواصفات الفنية

- ضغط التشغيل على تجهيزات الدش: ضغط التشغيل الموصى به.
- الحد الأقصى 0,6 ميجاباسكال  
0,25 - 0,5 ميجاباسكال  
(1 ميجاباسكال = 10 بار = 147 PSI)
- درجة حرارة الماء الساخن: الحد الأقصى 60°C
- درجة الحرارة الموصى بها للماء الساخن: 42°C
- حفظ أمان: 40°C
- تحذير: يمكن أن يؤدي تخطي درجة الحرارة هذه إلى إحتراقات!
- تعقيم حراري: الحد الأقصى 4/70°C الدقيقة
- الجهود الاسمي: 60Hz-240V AC 50-100
- الاستهلاك الاسمي: W 18
- المصابيح 4 LED x: 12V DC SELV 4 W
- مصباح الإنارة ليس عاكس للضوء. فئة الحماية: نوع الحماية: II
- IPX5
- ShowrHeaven 970
- الوزن (شامل التغليف) kg 47,9
- ShowrHeaven 720
- الوزن (بدون تغليف) kg 28,36
- المنتج مخصص فقط لماء الشرب!



## ▲ BIZTONSÁGI UTASÍTÁSOK

- ▲ A szerelésnél a zúzódások és vágási sérülések elkerülése érdekében kesztyűt kell viselni.
- ▲ A terméket csak fürdéshez, mosakodáshoz, és egészségügyi tisztálkodáshoz szabad használni.
- ▲ Gyermekek, valamint testileg, szellemileg fogyatékos és/vagy érzékelésben korlátozott személyek nem használhatják felügyelet nélkül a terméket. Alkohol és kábítószer befolyása alatt álló személyek nem használhatják a terméket.
- ▲ Kerülni kell a zuhanyugár érintkezését érzékeny testrészekkel (pl. szemek). Be kell tartani a megfelelő távolságot a zuhanyfej és a test között.
- ▲ A hidegvíz- és a melegvíz-csatlakozások közötti nagy nyomáskülönbséget kikell egyenlíteni!

## ELEKTROMOS CSATLAKOZÁS

- ▲ Az elektromos hálózathoz való csatlakoztatást csak szakember végezheti el!
- ▲ A feszültségellátást 100-240V/N/PE/50-60Hz (hosszúság: 1 m) előre létre kell hozni.
- ▲ A biztosítást egy hibaáram-mentesítő (RCD/FI) útján, egy 30 mA-nál kisebb hálózati váltóáram segítségével kell megvalósítani.
- ▲ A terméket egy az építkezésen meglévő potenciálkiegyenlítéshez (PA) 4 mm<sup>2</sup> kell csatlakoztatni.

## ELEKTROMOS SZAKEMBER

- ▲ Az installációs és ellenőrző munkákat jóváhagyott elektromos szakembernek kell elvégezni, a VDE 0100 701, IEC 60364-6 része és az IEC 60364-7-701, valamint az EN 60335-2-105 figyelembevételével.
- ▲ A hálózati csatlakozóvezetékét duplán szigetelve kell   csatlakozódobozba bevezetni.

## SZERELÉSI UTASÍTÁSOK

- / A szerelés előtt ellenőrizni kell, hogy a terméknek nincs-e szállítási sérülése. Beépítés után a szállítási- vagy felületi sérüléseket nem ismerik el.
- / A vezetékeket és a csaptelepet az érvényes szabványoknak megfelelően kell felszerelni, öblíteni és ellenőrizni
- / Az egyes országokban érvényes installációs irányelveket be kell tartani.
- / A termék képzett szakember általi felszerelése esetén ügyelni kell arra, hogy a rögzítési felület teljesen sima legyen (ne legyen kiálló fuga vagy csempe), a fal szerkezete a termék felszerelésére alkalmas legyen, és ne legyen gyenge pontja.
- / Fúrás esetén ügyelni kell az áram- és vízvezetésekre!
- / A kifolyási teljesítményt megfelelően kell dimenzionálni.
- / A zuhanyt csak zárószelep vagy szaniter csaptelep után szabad bekötni.

## MŰSZAKI ADATOK

Üzemi nyomás a csaptelep előtt:	max. 0,6 MPa
Ajánlott üzemi nyomás:	0,25 - 0,5 MPa
	(1 MPa = 10 bar = 147 PSI)
Forróvíz hőmérséklet:	max. 60°C
Forróvíz javasolt hőmérséklete:	42°C
Biztonsági zár:	40°C

Figyelmeztetés: Ezen hőmérséklet túllépése égési sérüléshez vezethet!

Termikus fertőtlenítés:	max. 70°C/4 perc
Névleges feszültség:	100-240V AC 50-60Hz
Névleges felvétel:	18 W
Lámpák 4 x LED:	12V DC SELV 4 W

A lámpa nem halványítható.

Védelmi osztály:	II
Védettség:	IPX5

ShowerHeaven 970

Súly (csomagolással együtt) 47,9 kg

ShowerHeaven 720

Súly (csomagolás nélkül) 28,36 kg

A terméket kizárólag ivóvízhez tervezték!

## SZIMBÓLUMOK LEÍRÁSA

-  Ne használjon ecetsavtartalmú szilikon!
-  MÉRLETET (lásd a oldalon 46)
-  ÁTFOLYÁSI DIAGRAM (lásd a oldalon 45)
-  SZERELÉSI PÉLDÁK (lásd a oldalon 35)
-  TARTOZÉKOK (lásd a oldalon 48)
-  TISZTÍTÁS (lásd a oldalon 54)
-  KARBANTARTÁS (lásd a oldalon 50)
-  Szűrők cseréje (lásd a oldalon 50)
-  Világítótest cseréje (lásd a oldalon 53)
-  Elektromos szakember
-  Vízcsatlakozás DN20 (Melegvíz)
-  Vízcsatlakozás DN20 (Hidegvíz)
-  A lefolyó teljesítményének 50l/percnél magasabbnak kell lenni
-  Lefolyó
-  Nyissuk meg a vizet.
-  Zárjuk el a vizet
-  Két munkaerő szükséges
-  Vigyázat! Forró felületek!
-  Viseljen védkesztyűt
-  Viseljen szemvédőt
-  Természetes szivacs
-  Vízkőoldó (citromsav alapú)
-  Kerülje a szemmel és bőrrel való érintkezést. Ha a termék a szembe jut, akkor bő vízzel mossa ki.
-  Áram be/ki



### △ 安全上の注意

- △ 施工の際は手を挟んだり怪我をしないように、手袋をはめてください。
- △ この製品は、体や手を洗う等の製品本来の目的以外には使用しないでください。
- △ 製品に関する危険性をご理解いただけない方や、身体や精神にハンディキャップがあり安全なご利用が困難なお子様や大人の方のご利用は控えてください。生命に重大な危険が及ぶことや、物的損害の危険があります。アルコールまたは薬物の影響下にある方の使用はできません。
- △ シャワー吐水を身体の敏感な部分 (例えば、目など) に使用しないでください。シャワーと身体の間には十分な距離をとってください。
- △ 給水・湯の圧力差は0.1(MPa)以内としてください。

### 電気の接続

- △ 電気工事は電気工事士のみが行うことができます (日本では関連法規に従って施工してください)!
- △ 電源100-240V/N/PE/50-60Hz (長さ: 1 m) を仮敷設します。
- △ このシステムは、定格感度電流が30 mA以下の漏電遮断器に接続してください (日本では関連法規に従って施工してください)。
- △ 製品は、現場手配・施工の接地線4mm<sup>2</sup>に接続する必要があります (日本では関連法規に従って施工してください)。

### 電気工事士

- △ 設置およびテスト作業は、VDE 0100/パート701 および IEC 60364-6ならびに IEC 60364-7-701、EN 60335-2-105により、認定された電気技師が行う必要があります (日本では関連法規に従って施工してください)。
- △ 電源ケーブルは、二重絶縁回されている接続ボックスで接続されている必要があります (日本では関連法規に従って施工してください)。

### 施工上の注意

- / 製品の施工前に輸送でのダメージがないか確認してください。施工後のキズ等のお申し出はお断りさせて頂いています。
- / 配管と水栓は、関連法規に従って施工、洗浄、および試験を行ってください。
- / 施工行う地域に適用される関連法規をお守りください。
- / 適切な資格を持つ方が製品の施工を行ってください。施工面が平らであること (躯体の凹凸やタイル等の段差がないこと)、壁の構造が製品の施工に適しており必要な強度があることを確認してください。
- / 穴あけの際は、埋設管 (電気と水道管、等) に注意してください!
- / 排水能力を満足するものがが必要です。
- / シャワーは、止水栓または飲料適合している水栓の2次側にもみ接続してください。

### 技術資料

水栓直前の流動圧:	最大 0,6 MPa
推奨使用水圧:	0,25 - 0,5 MPa (1 MPa = 10 bar = 147 PSI)
給湯温度:	最大 60°C
推奨給湯温度:	42°C
Safety Stop:	40°C

警告: この温度を上回ると火傷の危険性があります!









お湯による高温消毒:	最大 70°C/4 分
定格電圧:	100-240V AC 50-60Hz
定格消費:	18 W
照明 4 x LED:	12V DC SELV 4 W
電球は調光できません。	
保護クラス:	II
保護クラス:	IPX5

ShowerHeaven 970  
重量 (パッケージを含む) 47,9 kg

ShowerHeaven 720  
重量 (パッケージを含まず) 28,36 kg

この製品は飲料水での使用が前提となっています (日本においては水道法に適合する飲料水)!

### アイコンの説明

-  酢酸系シリコンをご使用にならないでください!
-  寸法 (次のページを参照 46)
-  流量曲線図 (次のページを参照 45)
-  施工例 (次のページを参照 35)
-  スペアパーツ (次のページを参照 48)
-  お手入れ方法 (次のページを参照 54)
-  メンテナンス (次のページを参照 50)
-  フィルター交換 (次のページを参照 50)
-  電球の交換 (次のページを参照 53)
-  電気工事士
-  配管接続 DN20 (温)
-  配管接続 DN20 (水)
-  排水能力は、50l/分以上必要です。
-  排水
-  開栓
-  止水
-  作業には2人必要です
-  高温の表面に注意!
-  保護手袋を着用してください
-  目の保護具を必ず着用してください
-  海綿スポンジ
-  カルキ除去剤 (クエン酸塩基)
-  目や皮膚に入らないように注意してください。製品が目に入った場合は、水で十分に洗い流してください。
-  電源のオンオフ



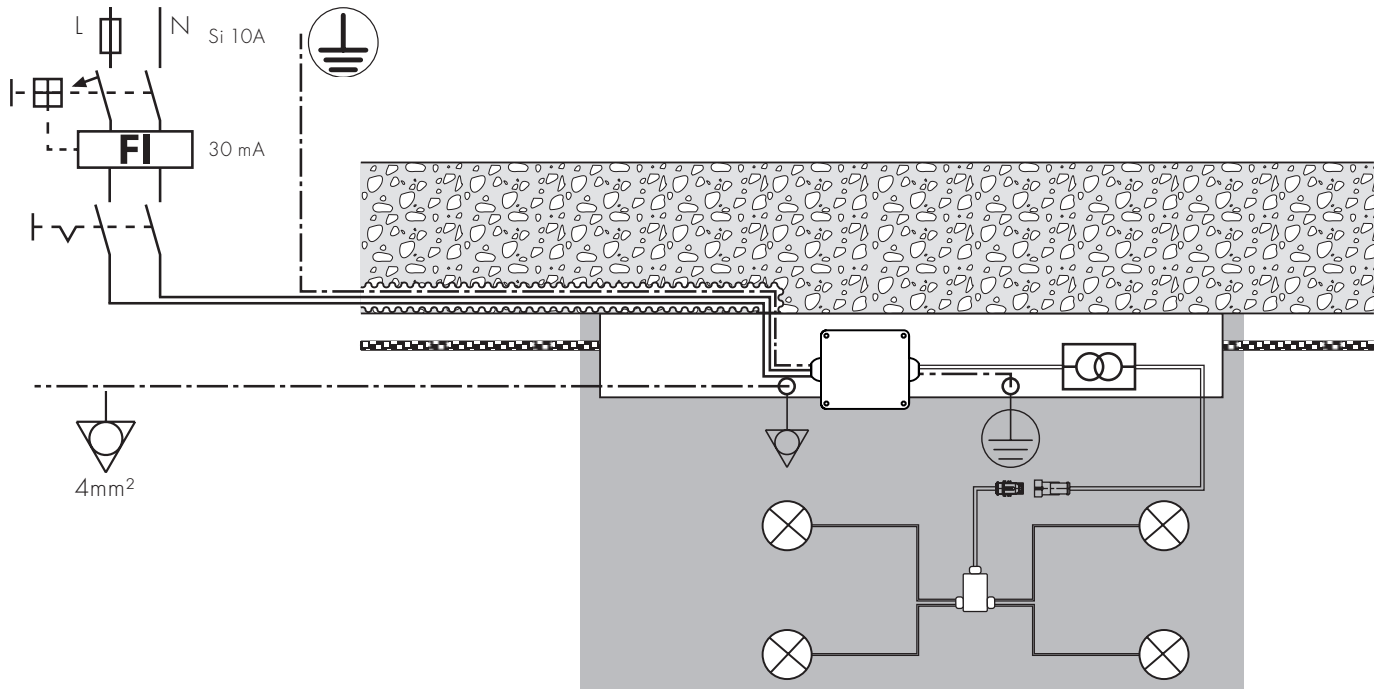

	PE/	PA/	N	L							
DE	Schutzleiteranschluss	Potentialausgleich (PA) 4 mm	Neutralleiter	Außenleiter	FI-Schutzschalter 30 mA	Lichtschalter	Anschlussdose	Netzteil 100 - 240V AC 50 W / 12V DC SELV	Leuchtmittel	Steckverbindungen	Verteilerbox
FR	Fil de protection	Compensation de potentiel (PA) 4 mm	Neutre	Conducteur	Disjoncteur FI 30 mA	Interrupteur d'éclairage	boîtier de raccordement	transfo 100 - 240V AC 50 W / 12V DC SELV	Moyen d'éclairage	Connecteur	Distributeur
EN	protective conductor connection	Potential equalisation (PA) 4 mm	neutral conductor	conductor	FI protective switch 30 mA	light switch	junction box	transformer 100 - 240V AC 50 W / 12V DC SELV	illuminant	connectors	distributor box
IT	conduttore di protezione	Compensazione di potenziale (PA) 4 mm	conduttore neutro	conduttore	interruttore di sicurezza per correnti di guasto 30 mA	interruttore luce	scatola di raccordo	trasformatore 100 - 240V AC 50 W / 12V DC SELV	Lampada	collegamenti a spina	cassetta distribuzione
ES	Conductor de puesta a tierra	Protección equipotencial (PA) 4 mm	Conductor neutro	Conductor	Commutador de protección FI 30 mA	Interruptor de luz	Caja de conexión	Transformador 100 - 240V AC 50 W / 12V DC SELV	Luces	Uniones insertables	Caja de distribución
NL	Aardingsaansluiting	Potentiaalvereffening (PA) 4 mm	Nulgeleider	Geleider	FI-veiligheidsschakelaar 30 mA	Lichtschakelaar	aansluiting	trafo 100 - 240V AC 50 W / 12V DC SELV	Verlichtingsmiddel	Steekverbinding	Verdeelbox
DK	Tilslutning til jordledning	Potentialudligning (PA) 4 mm	Nulleder	Leder	FI-beskyttelseskontakt 30 mA	lyskontakt	Tilslutningsdåse	Transformer 100 - 240V AC 50 W / 12V DC SELV	lyskilde	Stikforbindelser	Fordelingskasse
PT	ligação do condutor de protecção	ligação equipotencial (PA) 4 mm	Condutor neutro	Condutor	Interruptor FI 30 mA	Interruptor de luz	Caixa de derivação	Transformador 100 - 240V AC 50 W / 12V DC SELV	Lâmpada	Tomadas de ligação	Caixa de distribuição
PL	Przyłącze ochronne	Wyrównanie potencjału (PA) 4 mm	Przewód zerowy	Przewód	Wyłącznik różnicowoprądowy FI 30 mA	Wyłącznik oświetleniowy	Przyłącze	Transformator 100 - 240V AC 50 W / 12V DC SELV	Źródło światła	Połączenia wtykowe	Skrzynka połączeniowa
CS	Připojení ochranného vodiče	Vyrovňání potenciálů (PA) 4 mm	Nulový vodič	Vodič	Ochranný spínač FI 30 mA	Spínač světla	připojovací krabice	Transformátor 100 - 240V AC 50 W / 12V DC SELV	Osvětlovací prostředek	Konektorová spojení	Krabička rozdělovače
SK	Pripojenie ochranného vodiča	Vyrovňanie potenciálov (PA) 4 mm	Nulový vodič	Vodič	FI ochranný spínač 30 mA	Svetelný spínač	pripájacia krabica	Transformátor 100 - 240V AC 50 W / 12V DC SELV	Osvetlovací prostriedok	Konektorové spojenia	Skrinka rozdelovača
ZH	地线接口	电位均衡 (PA) 4 mm	零线	导线	FI保护开关 30 mA	照明开关	接线盒	变压器 100 - 240V AC 50 W / 12V DC SELV	灯具	插座连接	分线盒
RU	Разъем защитного провода	Выравнивание потенциалов (PA) 4 mm	Нулевой провод	Провод	Защитное реле FI 30 mA	Выключатель освещения	точка подключения	трансформатор 100 - 240V AC 50 W / 12V DC SELV	Осветительное средство	Штекерные соединения	Распределительная коробка
HU	Védővezeték csatlakozás	Potenciálkiegyenlítés (PA) 4 mm	Null-vezeték	Vezeték	FI-védőkapcsoló 30 mA	Világítás-kapcsoló	Csatlakozó doboz	Trafó 100 - 240V AC 50 W / 12V DC SELV	Világítás	Dugaszoló csatlakozások	Elosztó doboz
FI	Suojamaaliitäntä	Potentiaalitasaus (PA) 4 mm	Nollajohdin	Johdin	FI-suojakytkin 30 mA	Valokytkin	Liitäntärasia	Muuntaja 100 - 240V AC 50 W / 12V DC SELV	Valonlähde	Pistokeliitäntä	Jakorasia

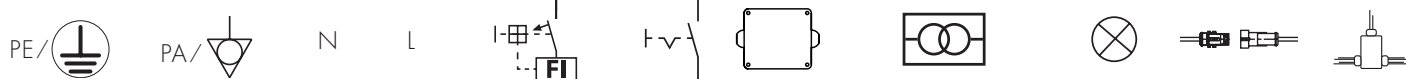
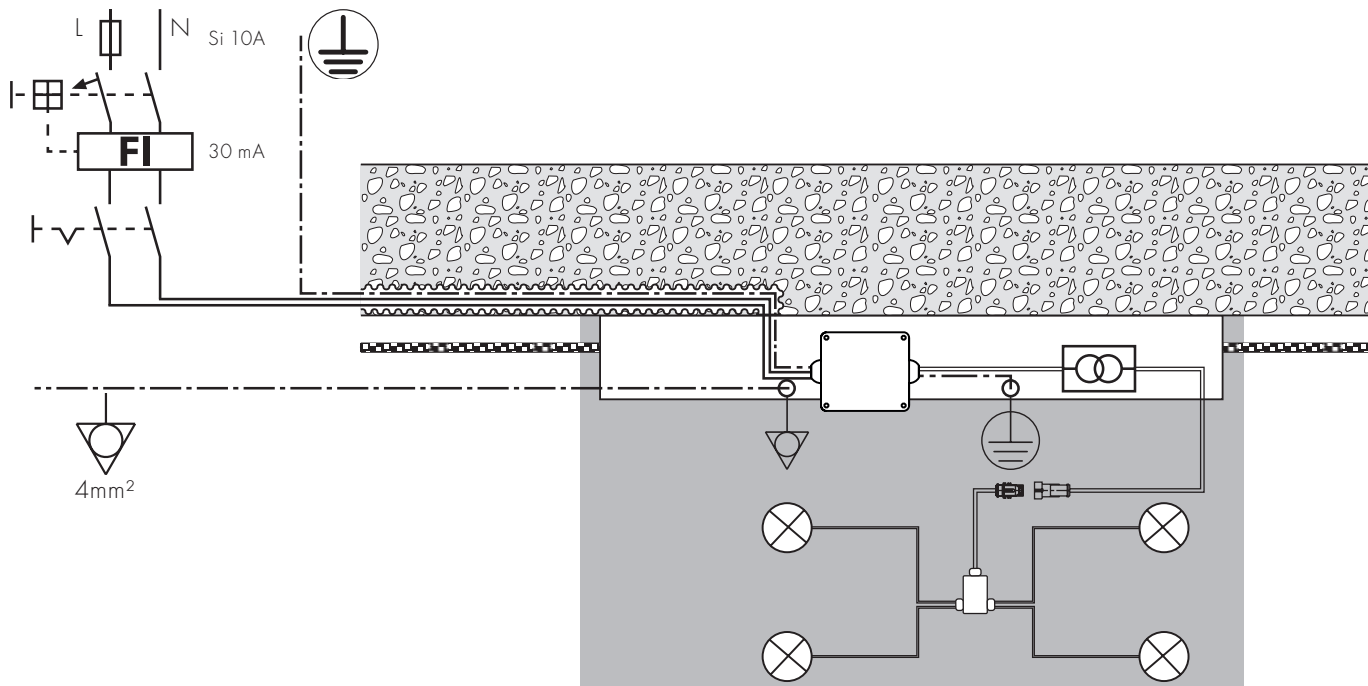

SV	Jordningsuttag	Potentialutjämning (PA) 4 mm	Neutral-ledare	Ledare	Jordfelsbrytare 30 mA	Strömbrytare	Anslutningsdosa	Transformator 100 - 240V AC 50 W / 12V DC SELV	Glödlampa	Stickanslutning	Fördelare
LT	apsauginio laido prievadas	Potencialų išlyginimas (PA) 4 mm	nulinis laidas	laidas	FI apsauginis jungiklis 30 mA	elektros jungiklis	Prijungimo dėžutė	Transformatorius 100 - 240V AC 50 W / 12V DC SELV	Šviesos šaltinis	kištukinės jungtys	skirstomoji dėžutė
HR	Priključak zaštitnog vodiča	Izjednačenje potencijala (PA) 4 mm	Nulti vodič	Vodič	FI-sklopka 30 mA	Prekidač za svjetlo	utičnica	transformator 100 - 240V AC 50 W / 12V DC SELV	Rasvjetno tijelo	Utični spojevi	Razdjelna kutija
TR	Koruyucu iletken bağlantısı	Potansiyel dengelemesi (PA) 4 mm	Sıfır iletken	İletken	FI koruma şalteri 30 mA	Işık şalteri	Bağlantı kutusu	Trafo 100 - 240V AC 50 W / 12V DC SELV	Ampul	Soket bağlantıları	Dağıtıcı kutu
RO	Conexiune conductor de protecție	Egalizare de potențial (PA) 4 mm	Fir neutru	Conducător	Întreruptor de protecție FI 30 mA	Întreruptor de lumină	Cutie de racord	Transformator 100 - 240V AC 50 W / 12V DC SELV	Lumină	Conexiuni	Cutie de distribuție
EL	Σύνδεση γείωσης	Εξίσωση δυναμικού (PA) 4 mm	Ουδέτερος	Αγωγός	Διακόπτης προστασίας FI 30 mA	Διακόπτης φωτισμού	Κουτί σύνδεσης	Trafo (μετασχηματιστής) 100 - 240V AC 50 W / 12V DC SELV	Φωτιστικό	Ηλεκτρικοί συνδετήρες	Κουτί διανομής
SL	Priključek zaštitnega vodnika	Potencialna izenačitev (PA) 4 mm	Ničelni vodnik	Vodnik	Zaščitno tokovno stikalo 30 mA	Stikalo za luč	Priključnica	Trafo 100 - 240V AC 50 W / 12V DC SELV	Svetilo	Vtične povezave	Razdelilna doza
ET	maandusjuhtme ühendus	Potentsiaali tasakaalustamine (PA) 4 mm	neutraaljuhe	juhe	kaitse 30 mA	valguslülii	harukarp	transformaator 100 - 240V AC 50 W / 12V DC SELV	Valgusti	pistikühendus	harukarp
LV	zemējuma vada pieslēgvietā	Potenciāla izlīdzināšana (PA) 4 mm	nulles vads	vads	drošinātājs 30 mA	gaismas slēdzis	Pieslēguma rozete	Transformators 100 - 240V AC 50 W / 12V DC SELV	Apgaismes ķermenis	spraudkontakti	sadales kārba
SR	Priključak zaštitnog provodnika	Izjednačenje potencijala (PA) 4 mm	Nulti provodnik	Provodnik	FI-sklopka 30 mA	Prekidač za svjetlo	utičnica	transformator 100 - 240V AC 50 W / 12V DC SELV	Svetiljka	Utični spojevi	Razvodna kutija
NO	Jordledningstilkobling	Potensialutjevning (PA) 4 mm	Nulleleder	Leder	FI-vernebryter 30 mA	lysbryter	Koblingskontakt	Transformator 100 - 240V AC 50 W / 12V DC SELV	lysmiddel	Pluggforbindelse	Fordelerboks
BG	Извод на защитния проводник	Изравняване на потенциала (PA) 4 mm	Нулев проводник	Проводник	Защитен прекъсвач погрешен ток за осветление 30 mA	Прекъсвач нито осветлителна кутия	Присъединителна кутия	Трансформатор 100 - 240V AC 50 W / 12V DC SELV	Осветително тяло	Щепселни съединения	Разпределителна кутия
SQ	Lidhja e tokëzimit	Barazimi i potencialeve (PA) 4 mm	Lidhja neutrale	Lidhje	Çelësi mbrojtës FI 30 mA	Çelësi i dritës	Kutia lidhëse	Trafo 100 - 240V AC 50 W / 12V DC SELV	Ndriçuesi	Lidhjet e prizave	Kutia shpërndarëse

AR	توصيلة الحماية الكهربائية	معادلة الجهد الكهربائي (PA) 4 mm	الموصل المحايد	موصل	مفتاح حماية FI 30 mA	مفتاح إضاءة	نقطة التوصيل	محول 100 - 240V AC 50 W / 12V DC SELV	مادة إضاءة	توصيلات قابسية	صندوق توزيع
----	---------------------------	----------------------------------	----------------	------	----------------------	-------------	--------------	---------------------------------------	------------	----------------	-------------

JP	アース線の接続	アース (PA) 4 mm	アース線	外部配管	漏電遮断器 30 mA	照明スイッチ	ジョイントボックス	変圧器 100 - 240V AC 50 W / 12V DC SELV	電球	コネクタ 配線接続ボックス	クス
----	---------	---------------	------	------	-------------	--------	-----------	--------------------------------------	----	---------------	----

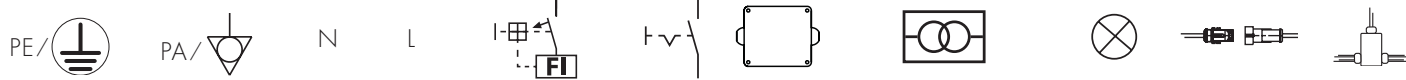

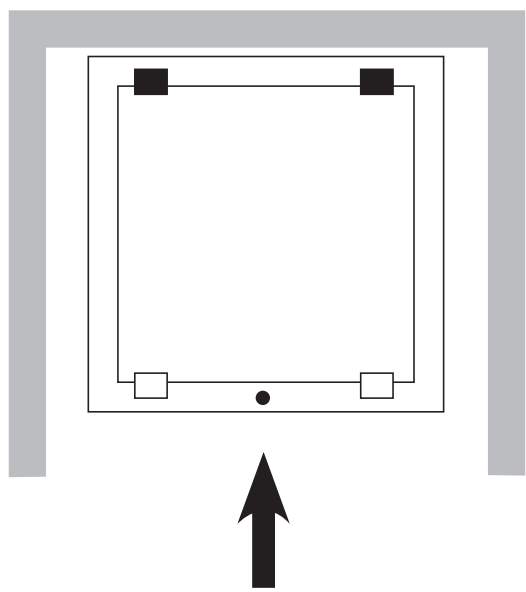
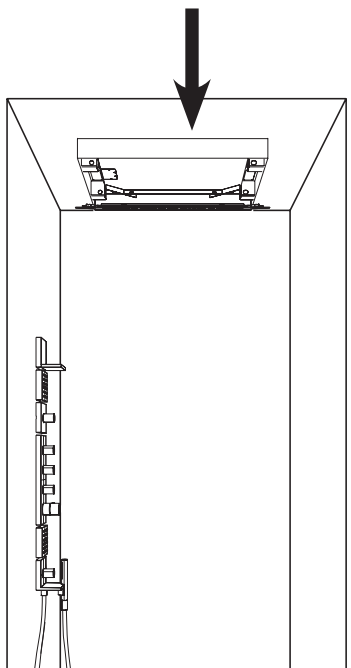
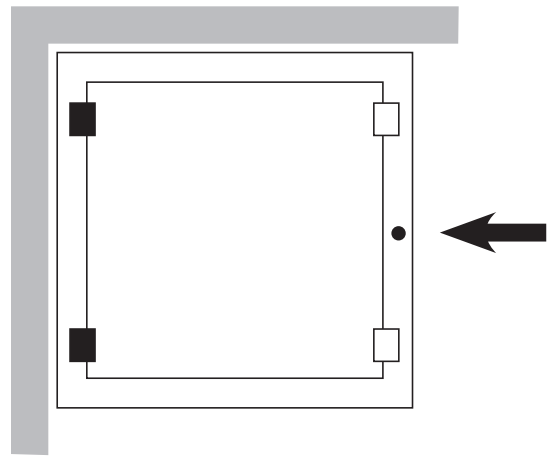
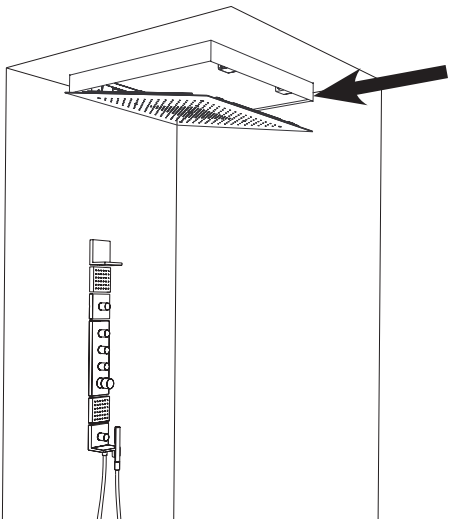
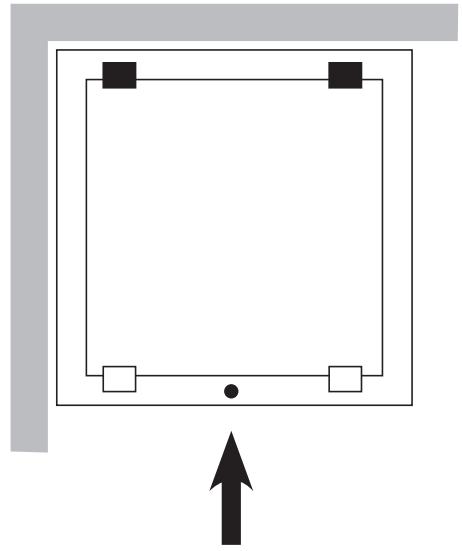
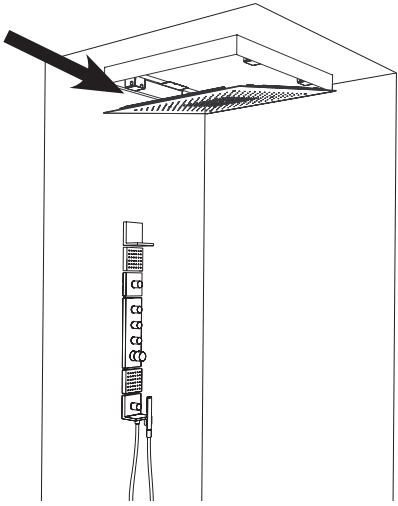

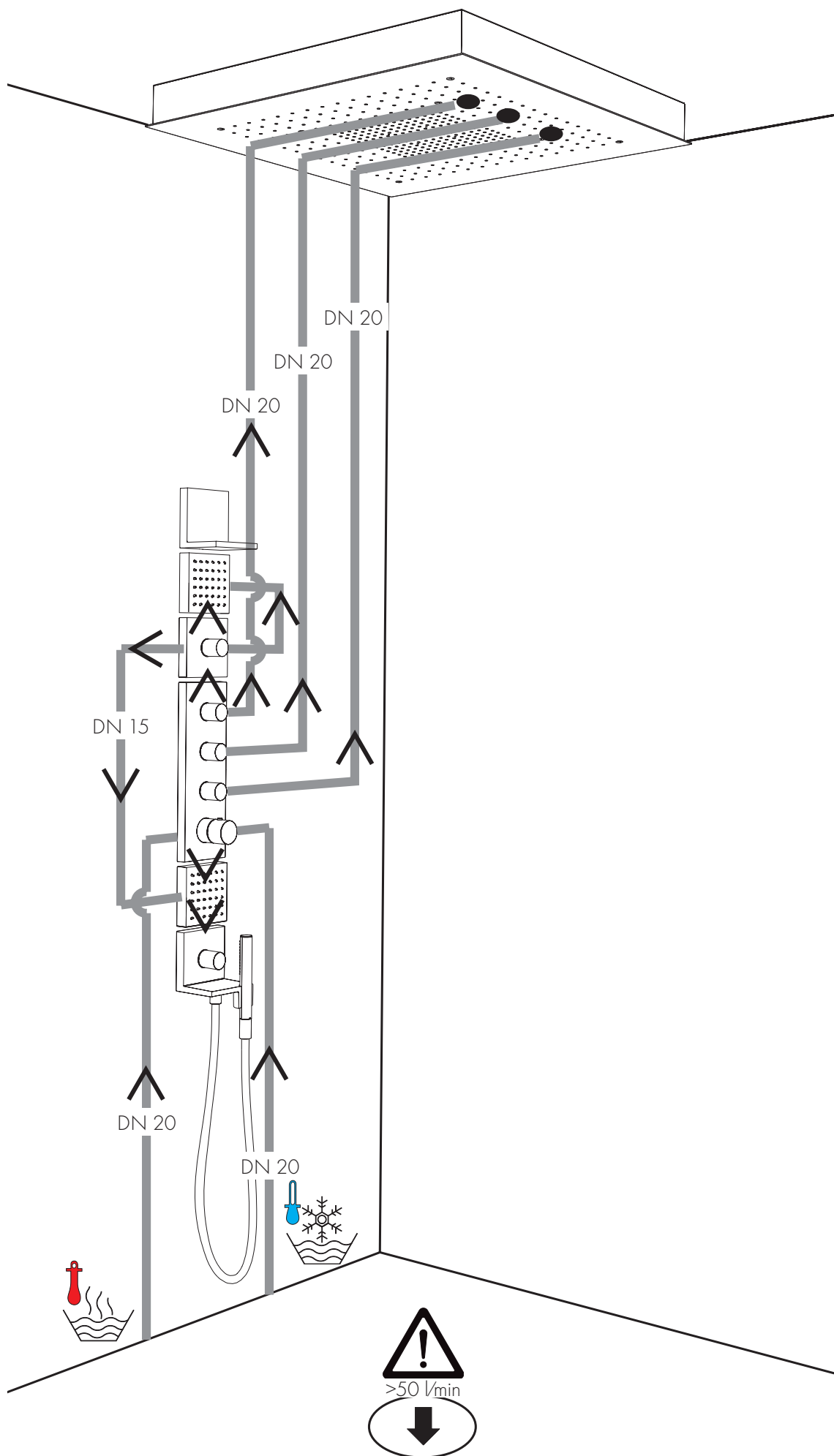

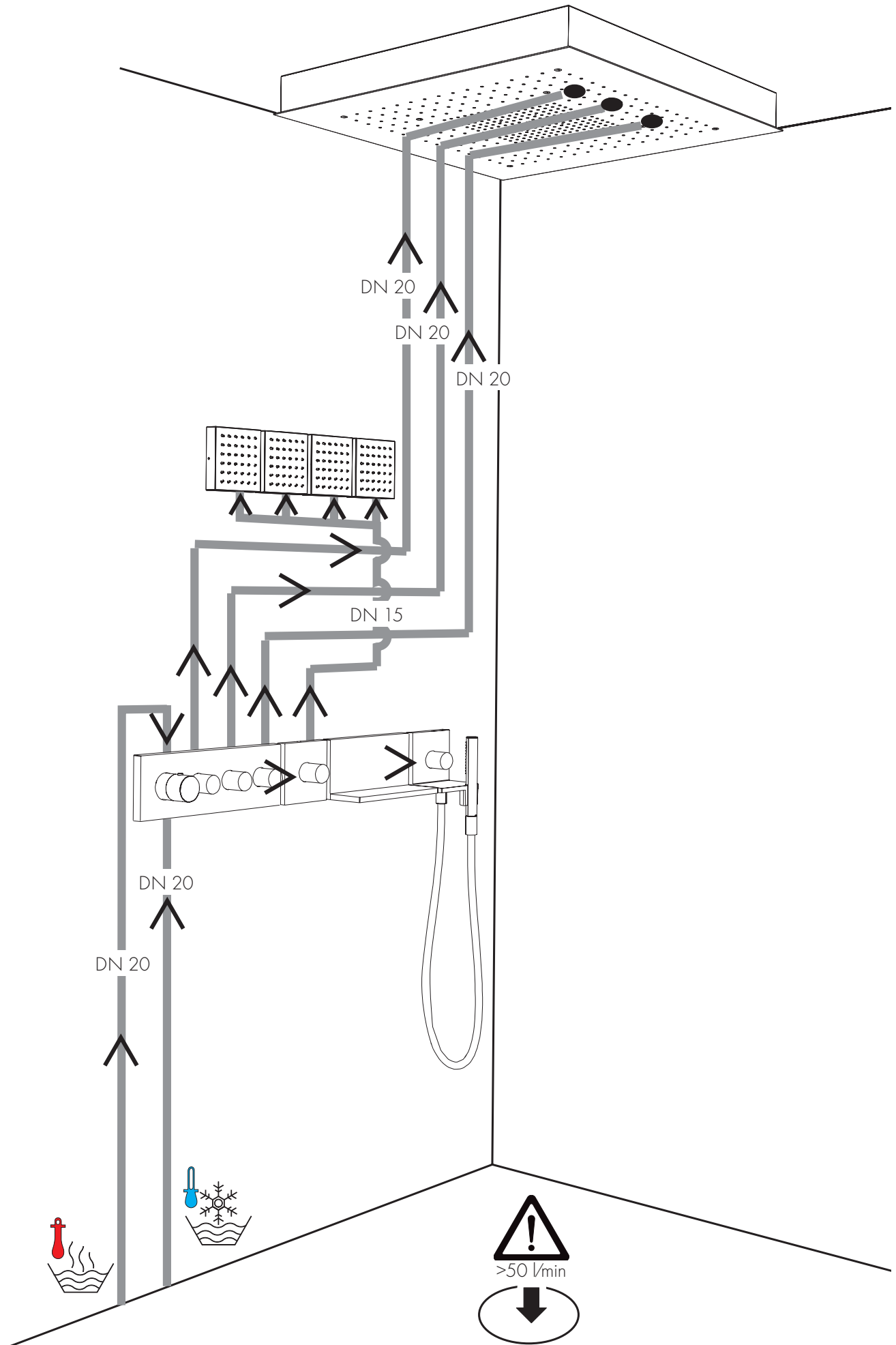

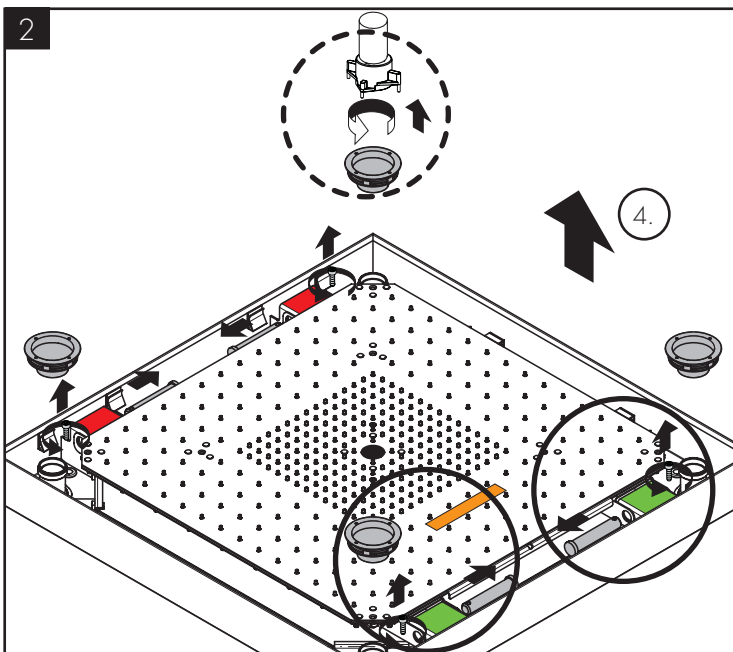
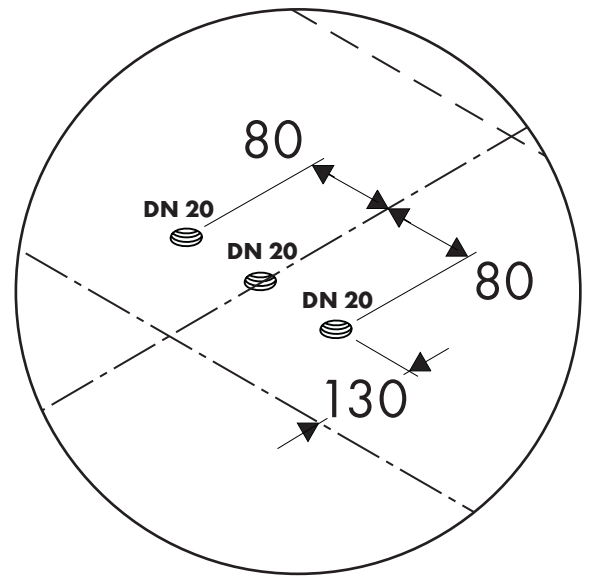
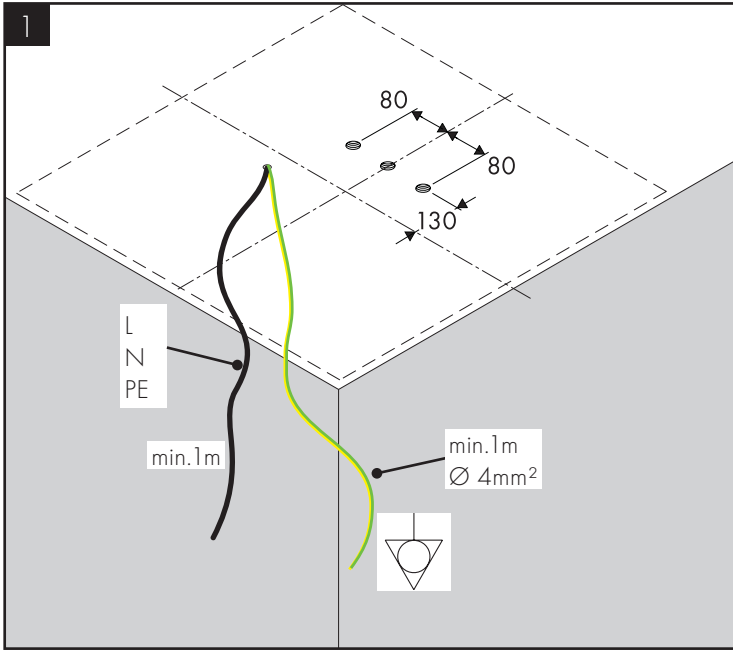

SW 5 mm

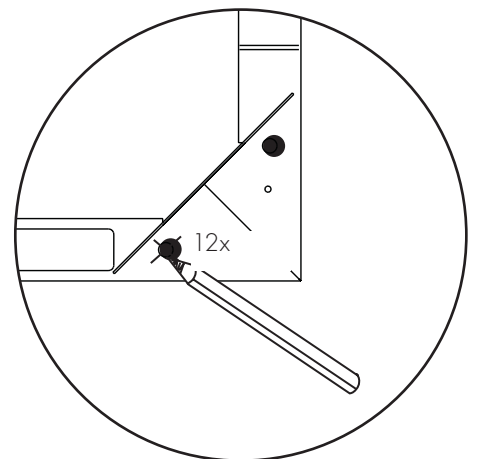
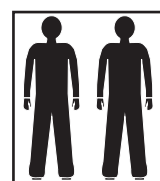
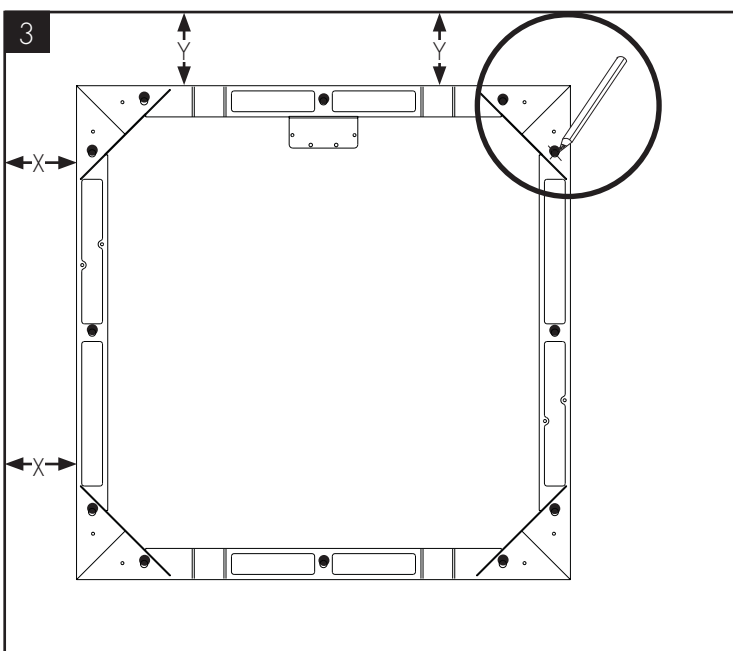
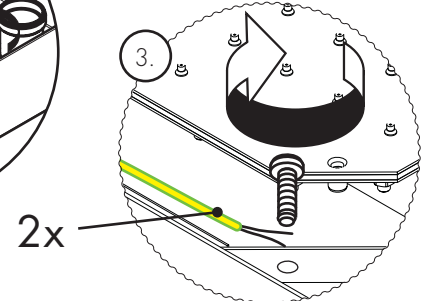
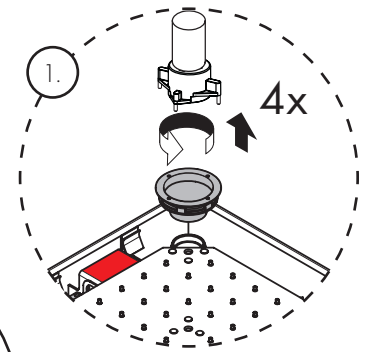
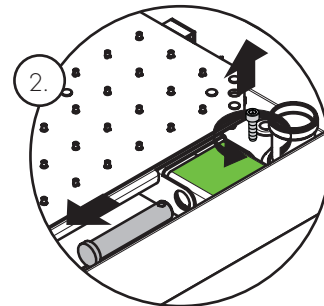

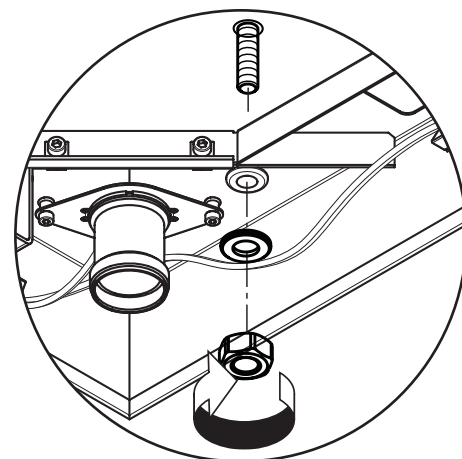
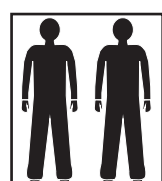
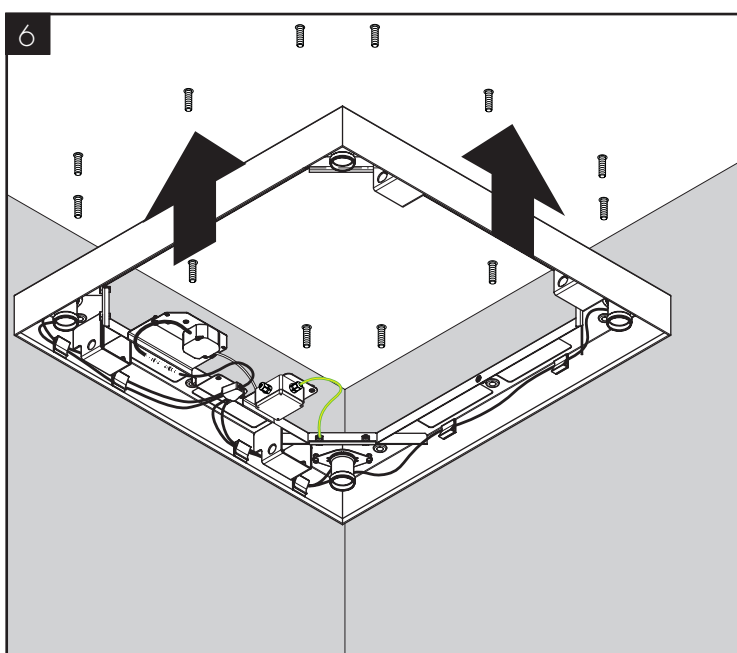
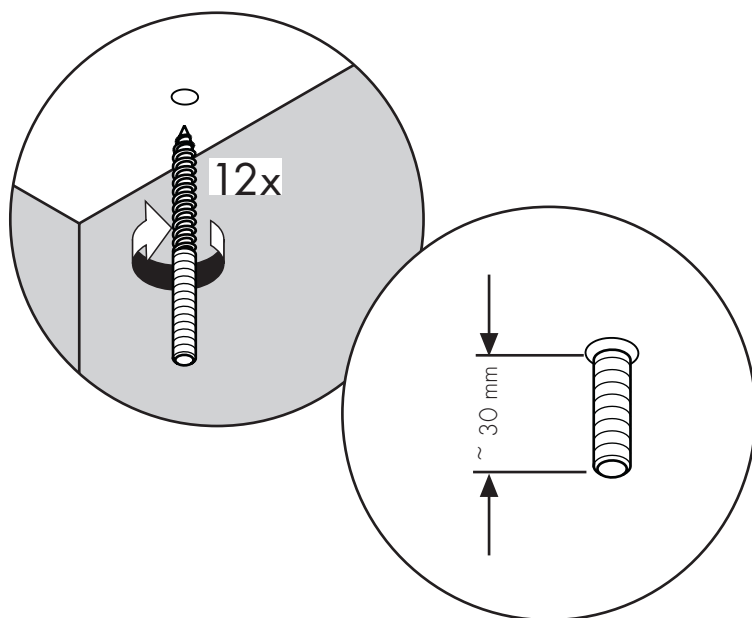
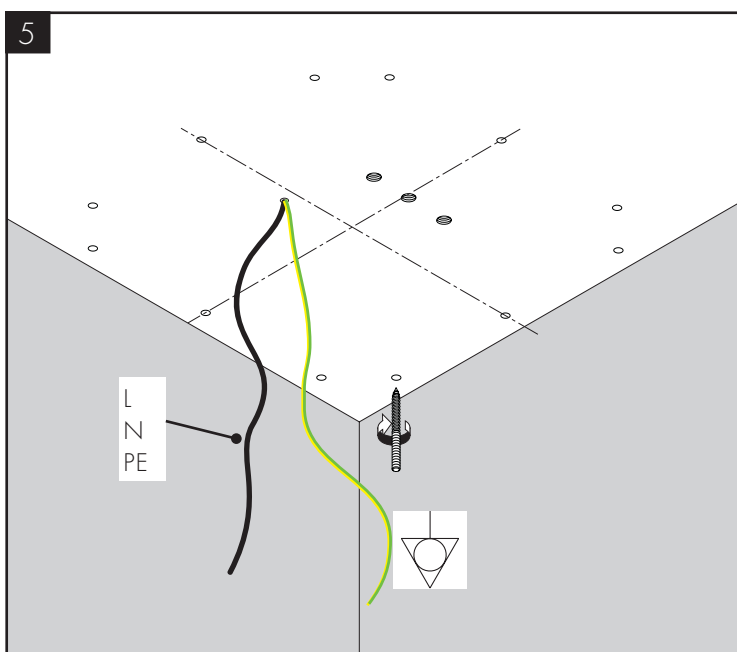
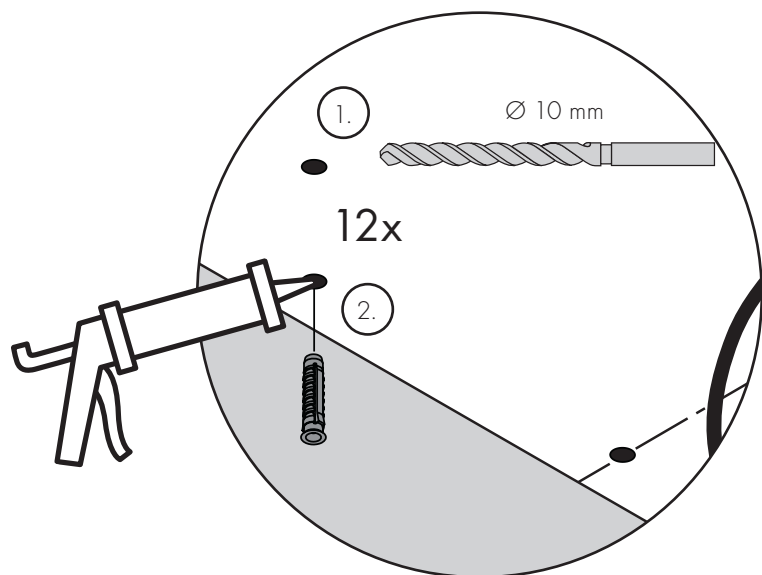
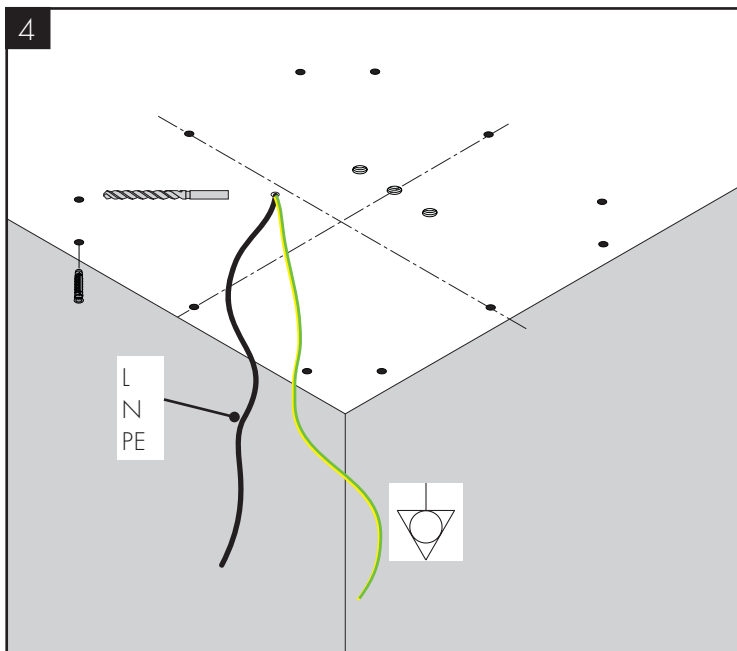

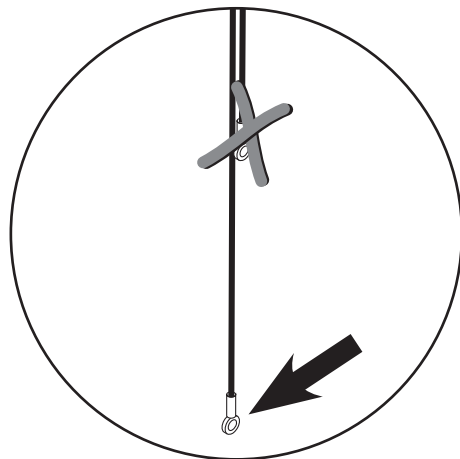
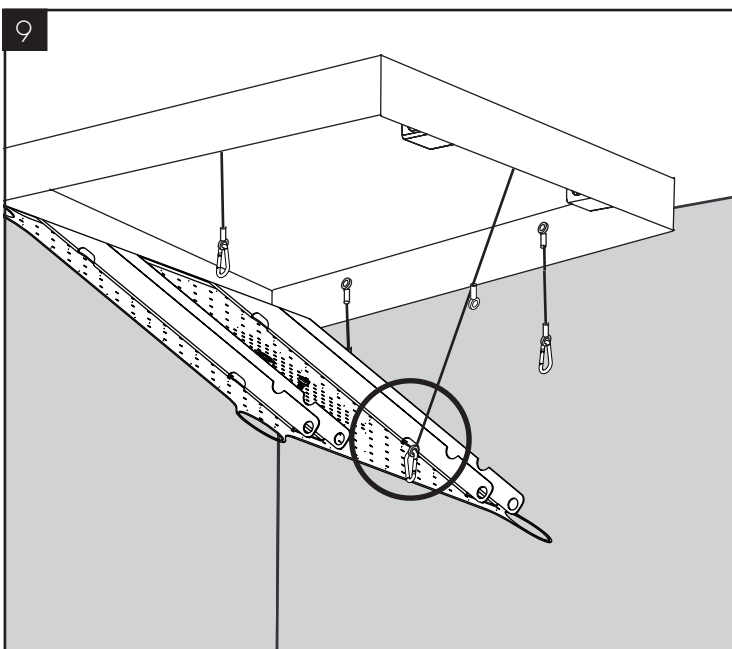
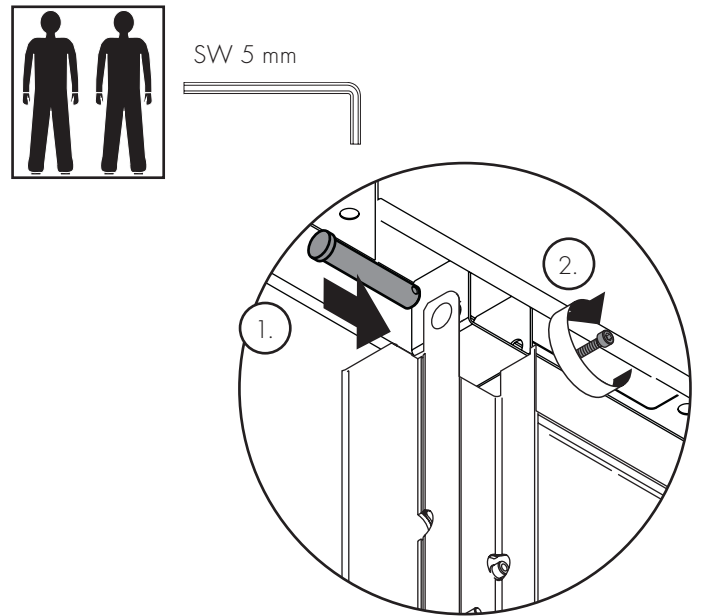
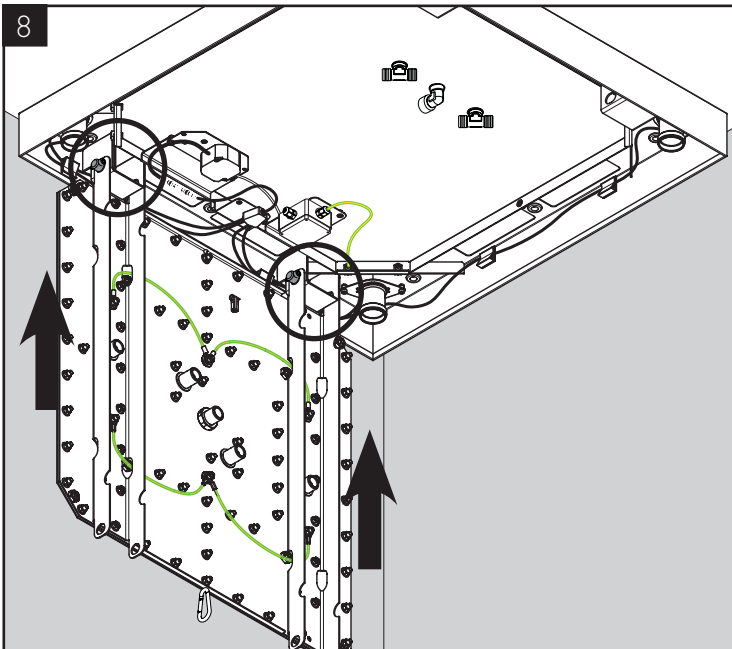
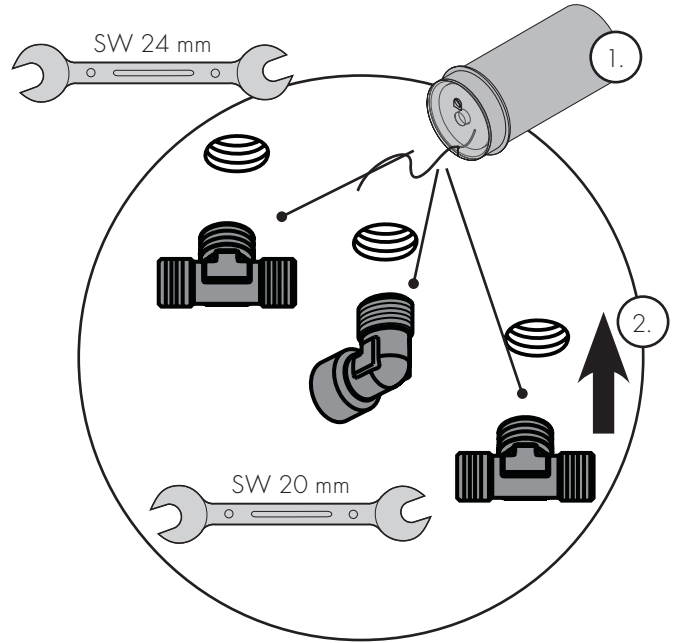
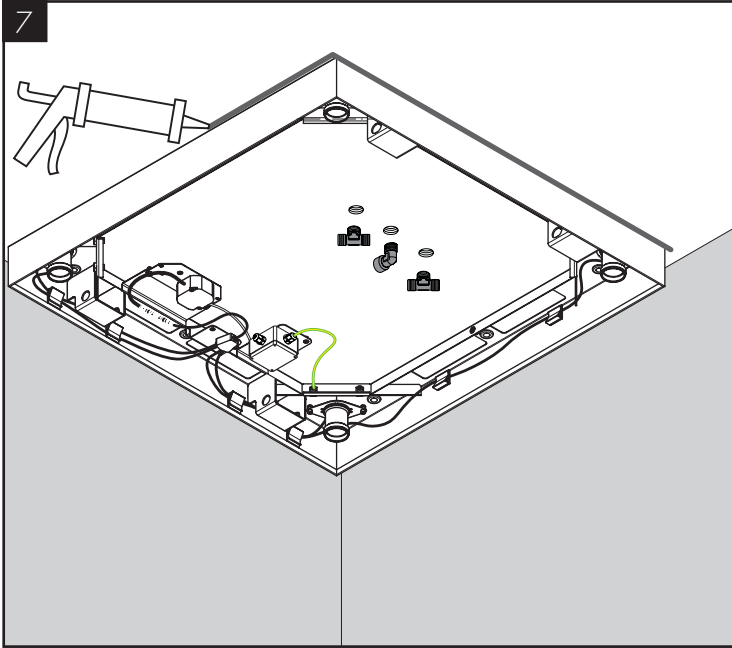





10 10621800 / 10625800

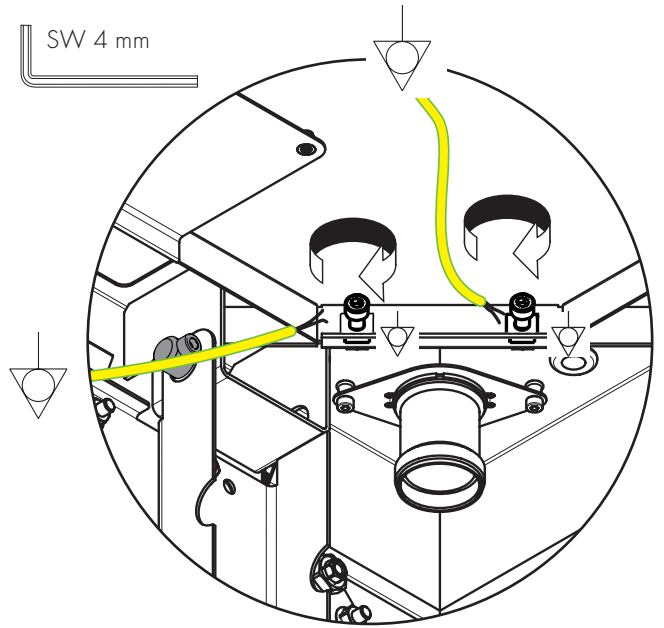
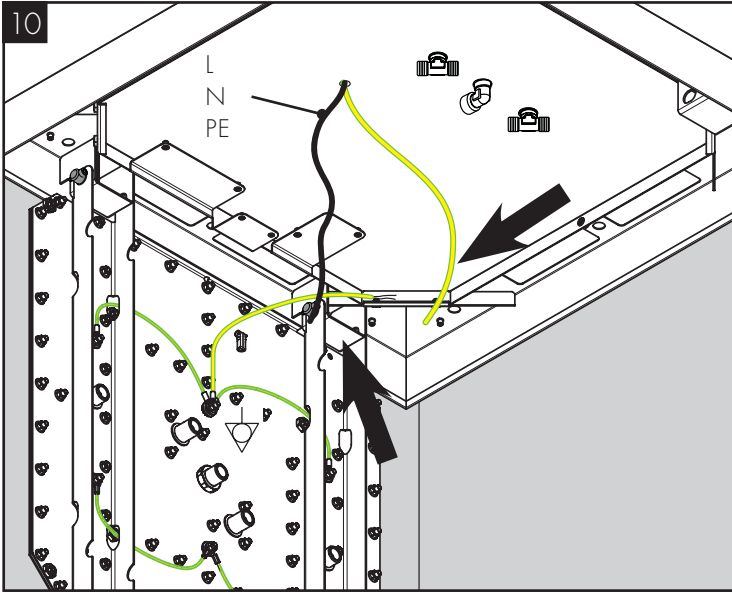

10 + 10a 10623800 / 10627800

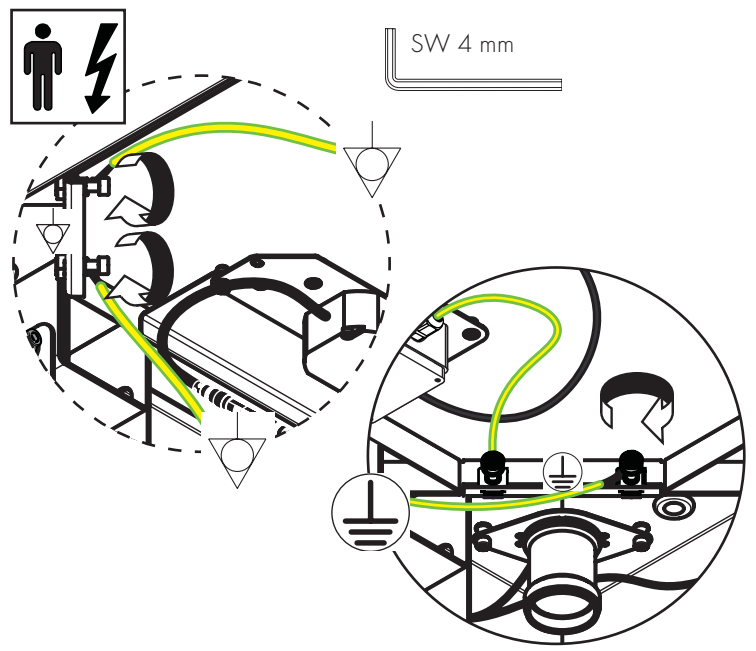
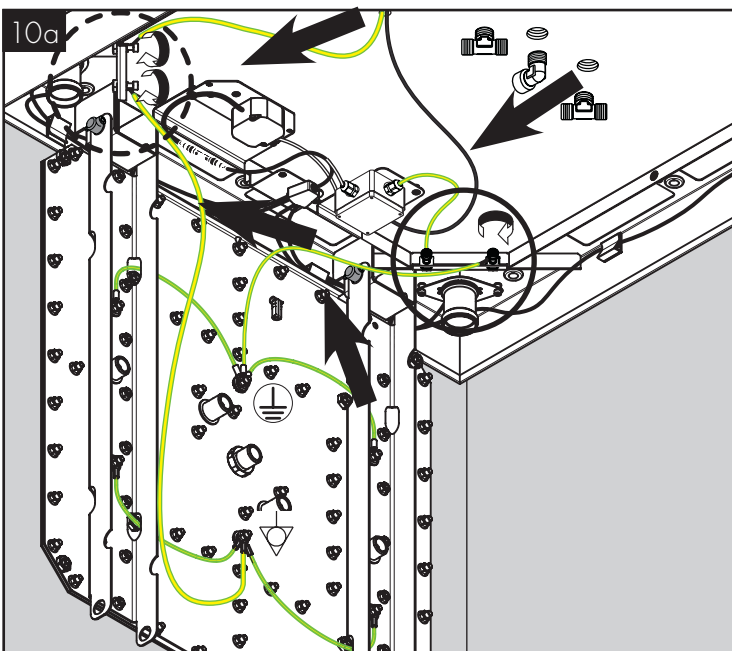
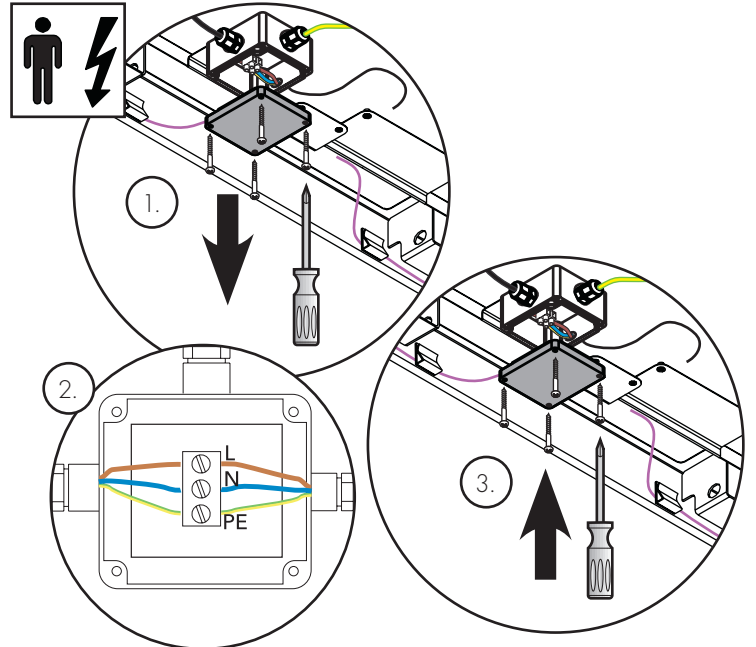
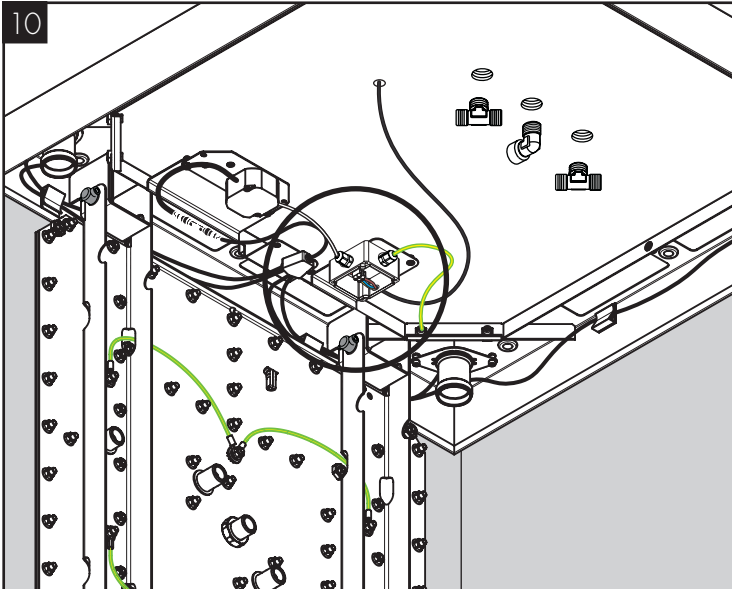

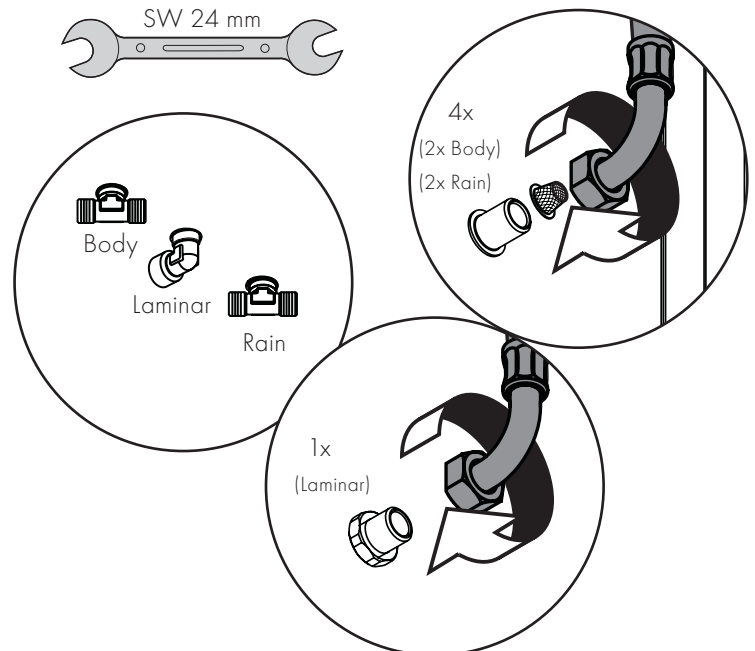
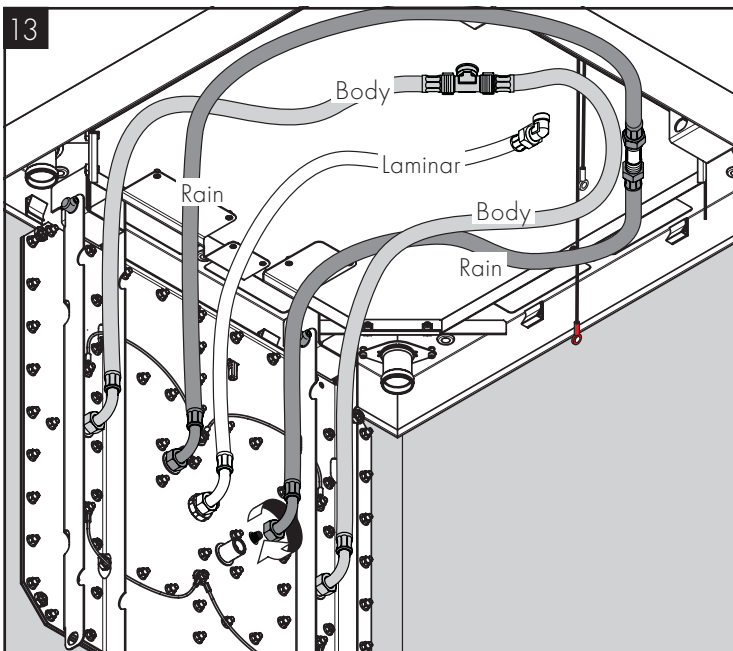
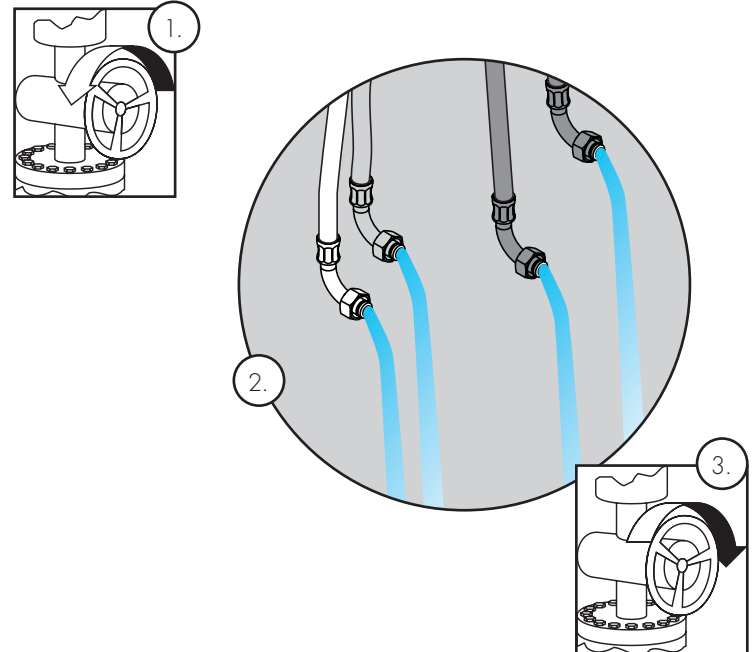
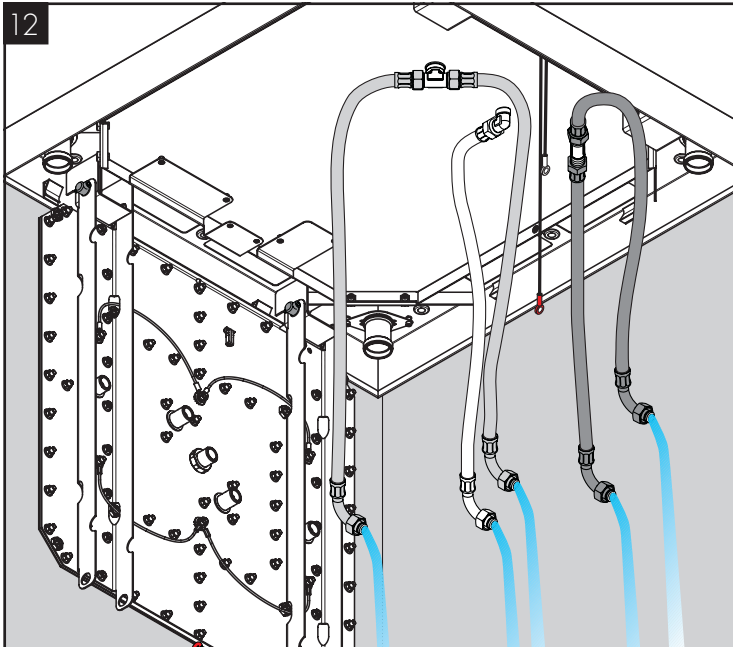
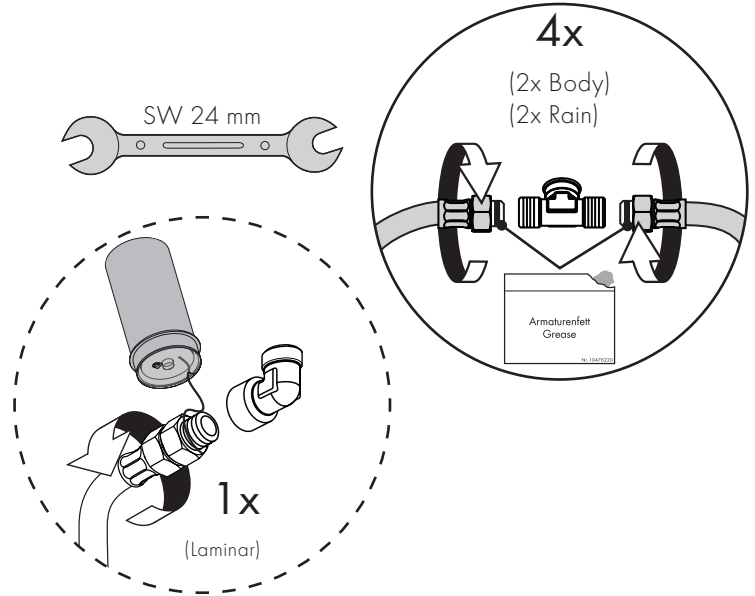
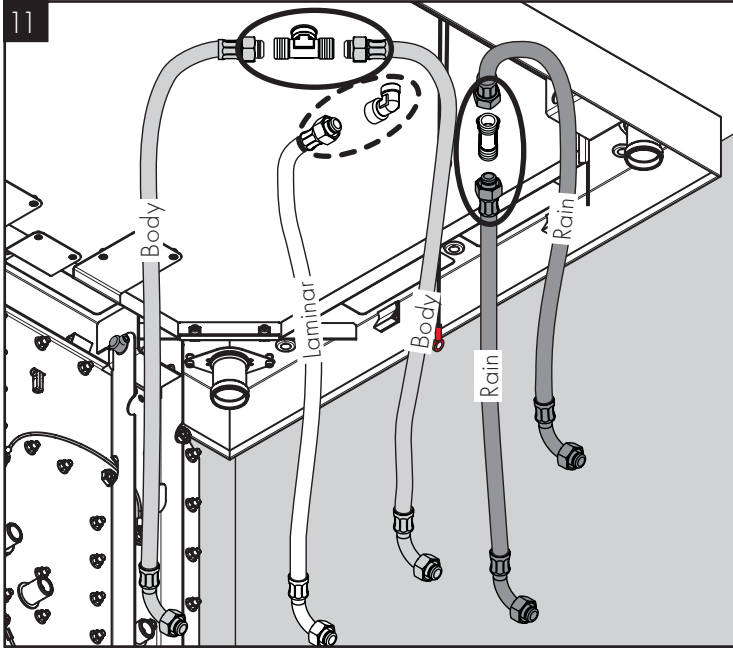

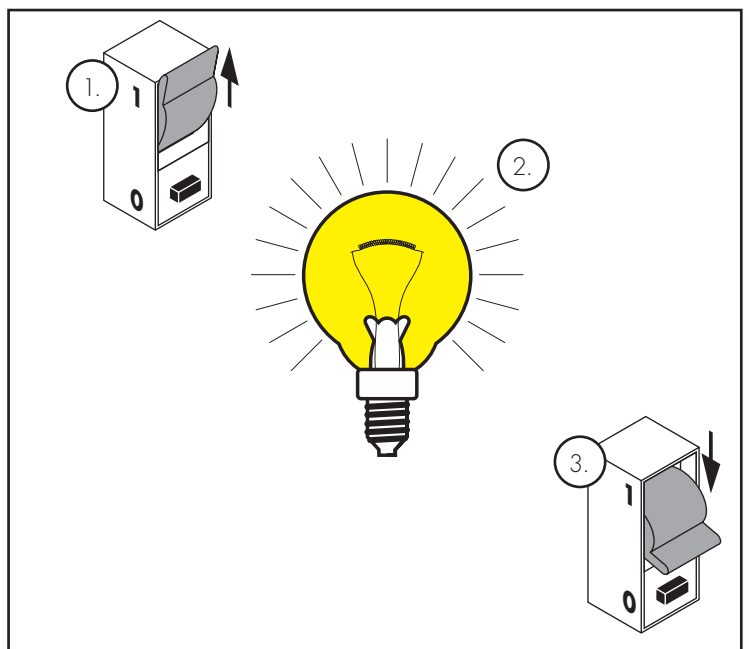
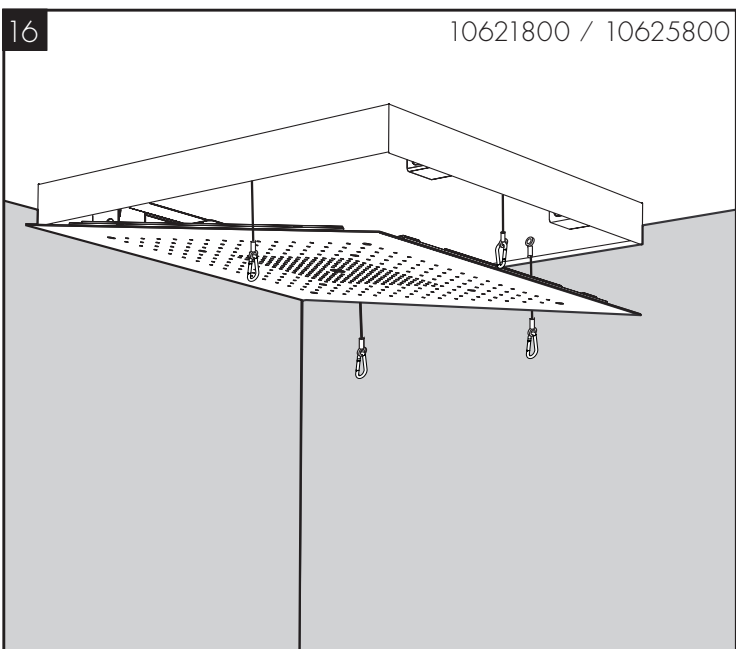
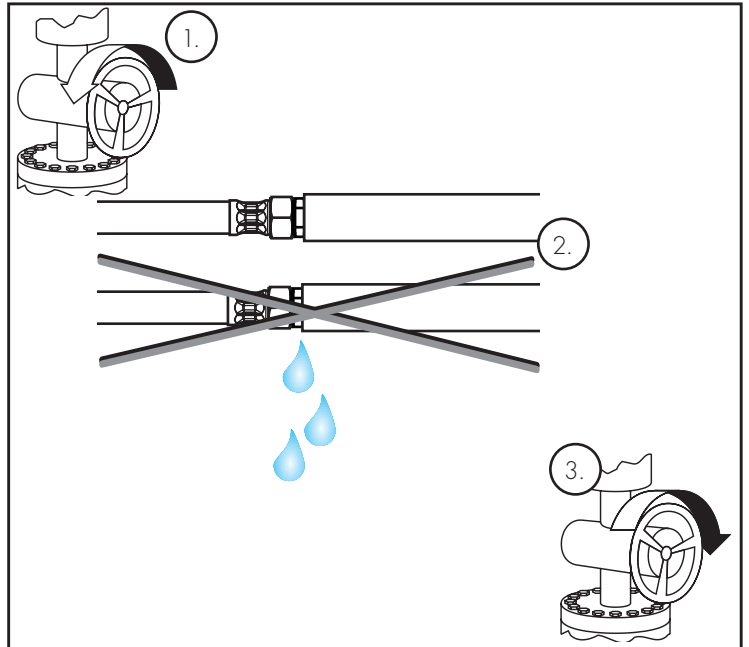
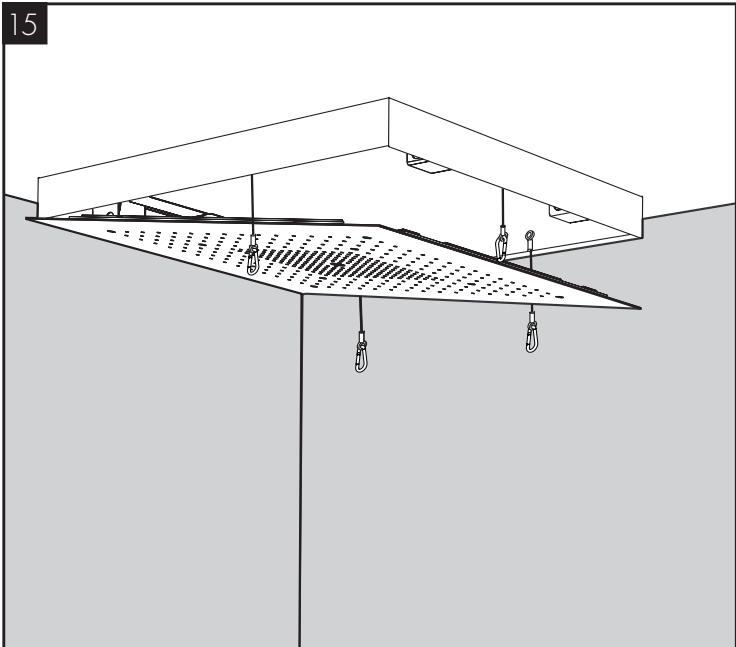
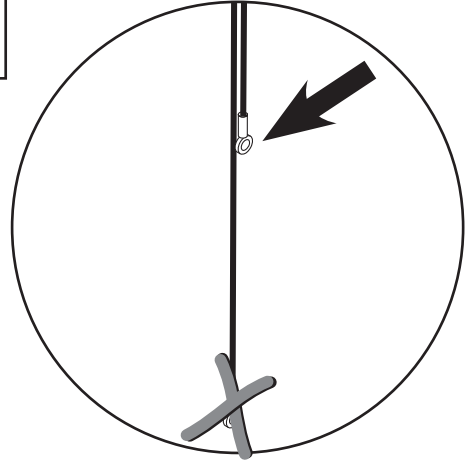
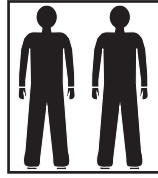
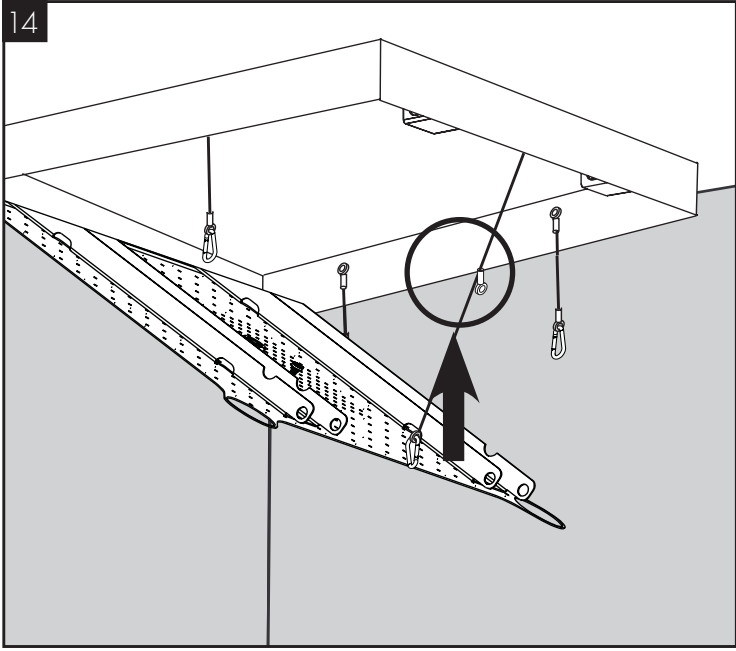

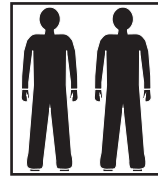
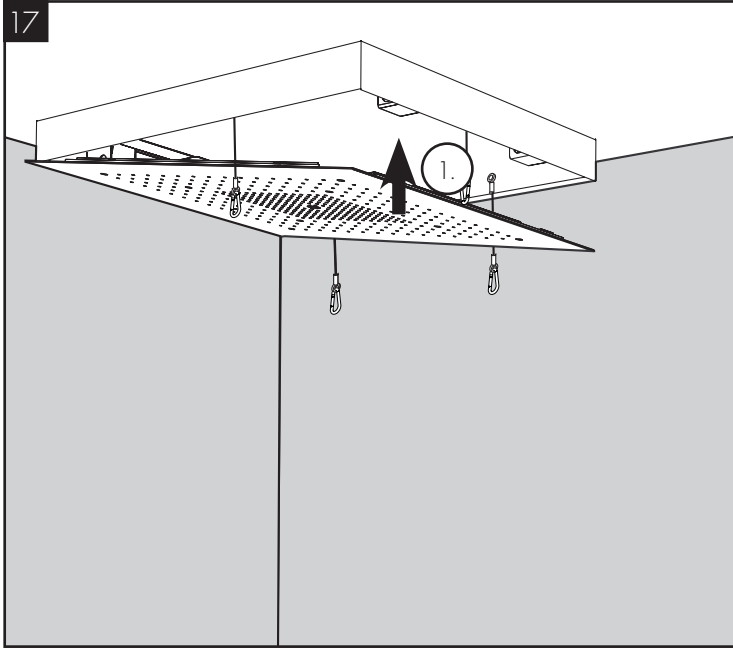

SW 5 mm

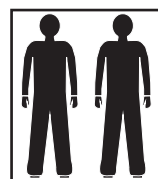
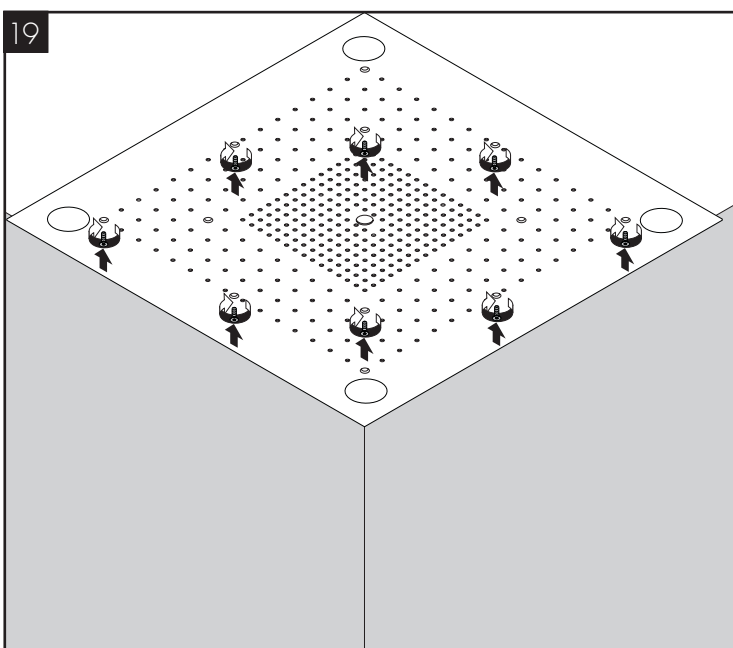
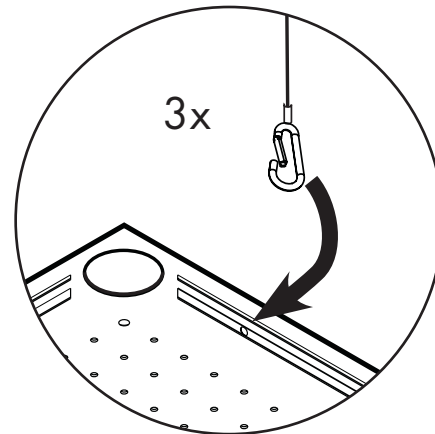
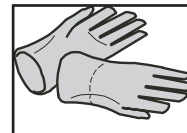
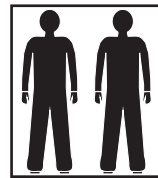
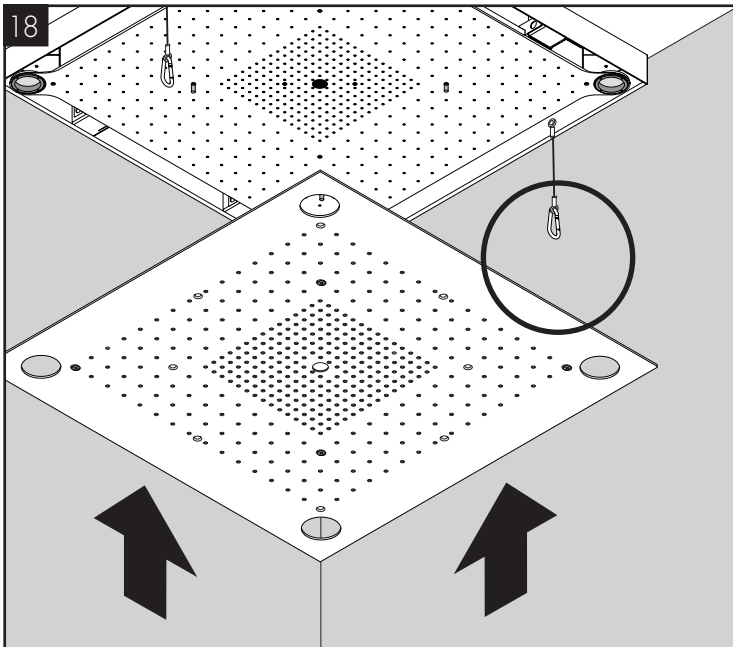
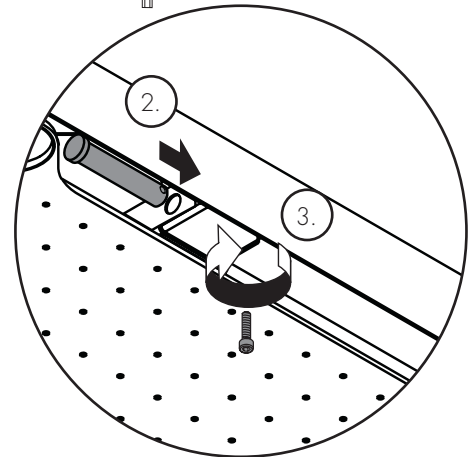

SW 4 mm

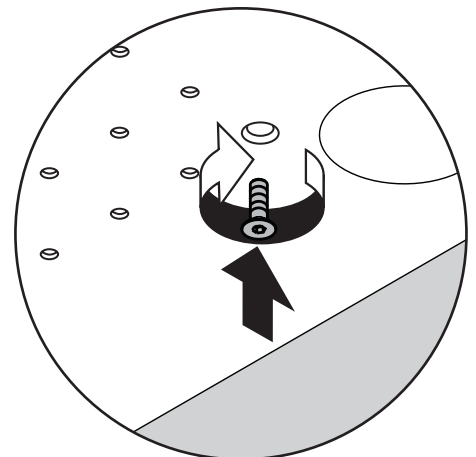

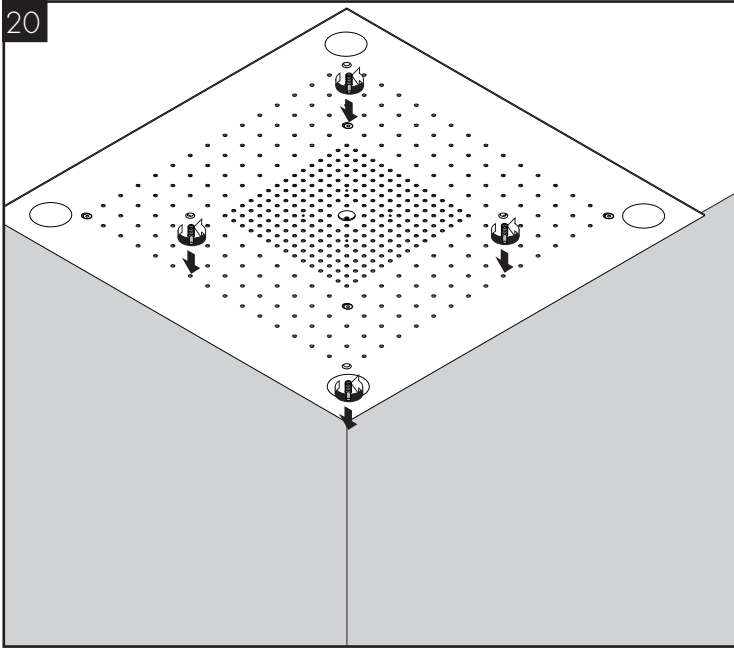

SW 4 mm

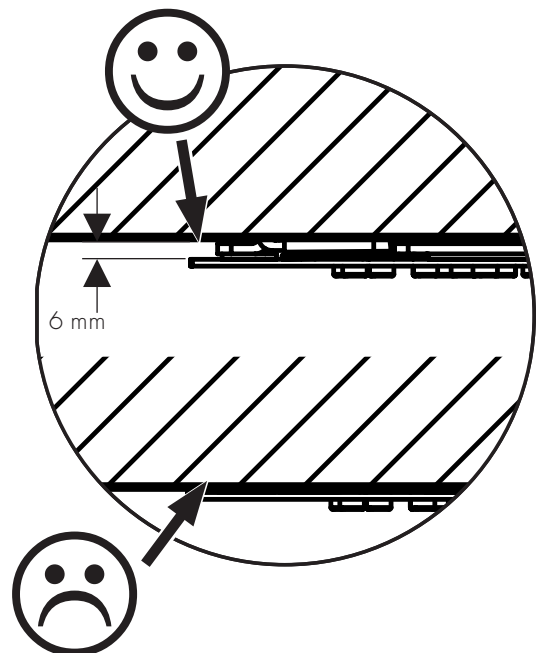
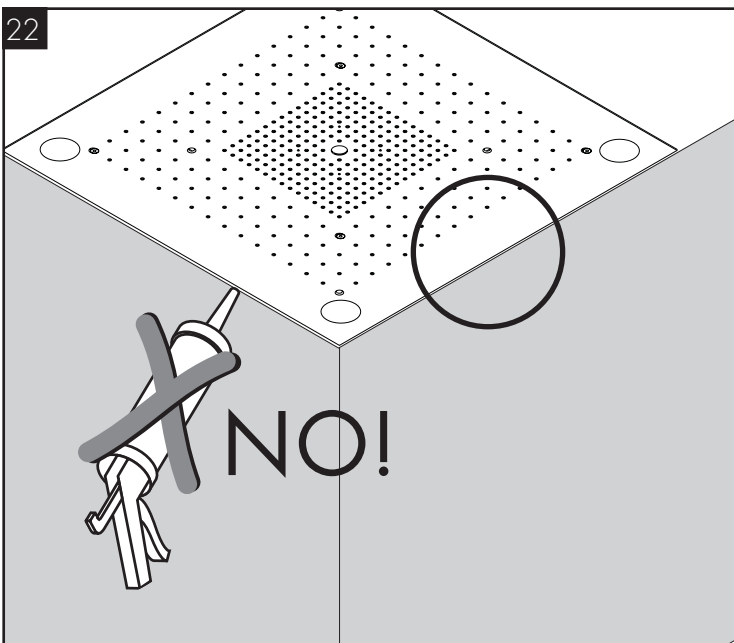
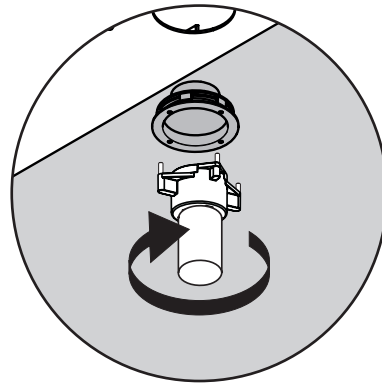
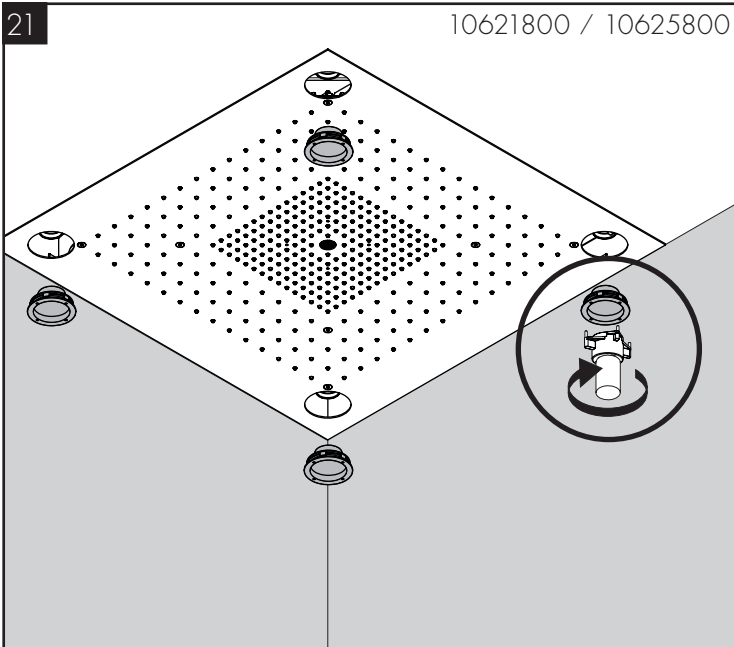
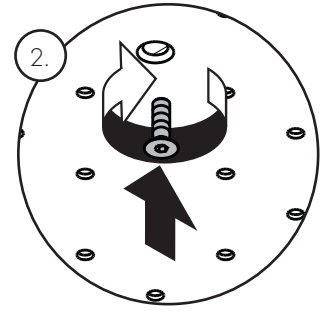
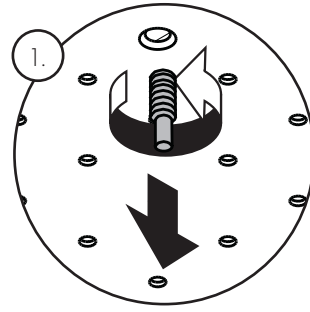



AXOR ShowerHeaven 720 3je

10625800 / 10627800

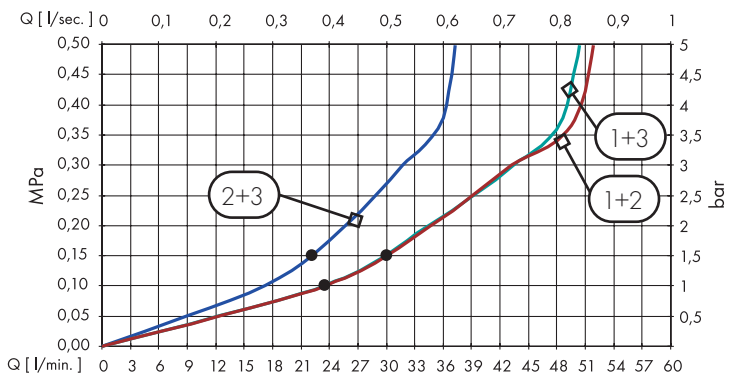
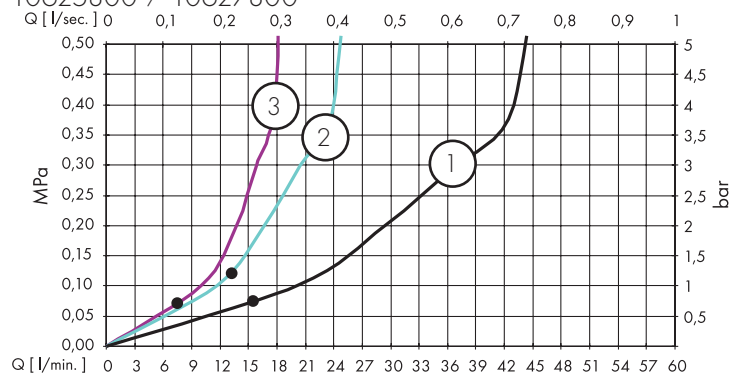

AXOR ShowerHeaven 970 3je

10621800 / 10623800

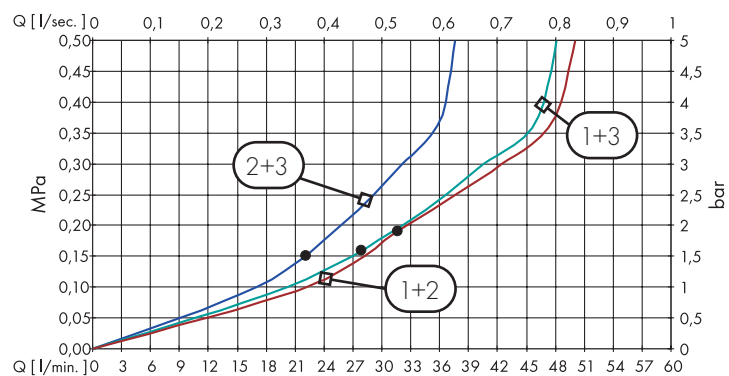
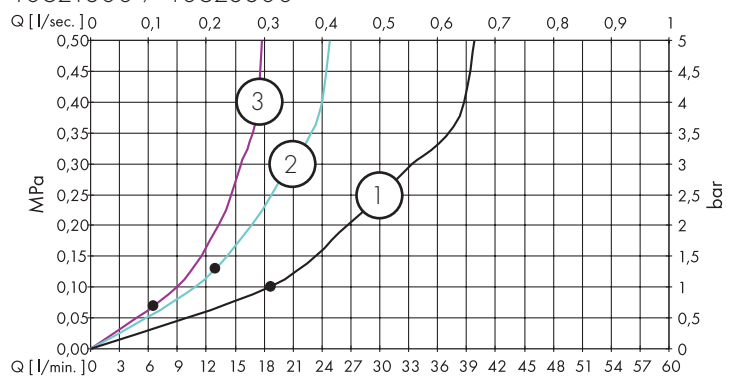

Body

Rain

Laminar

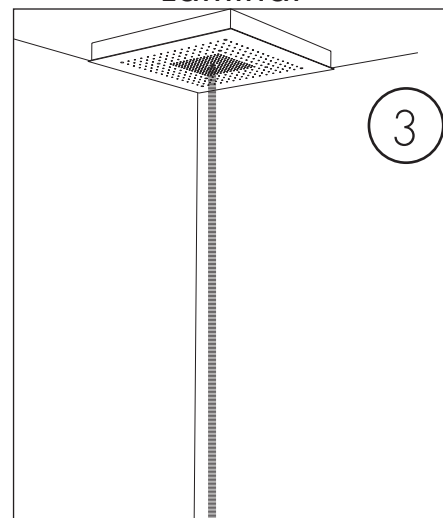
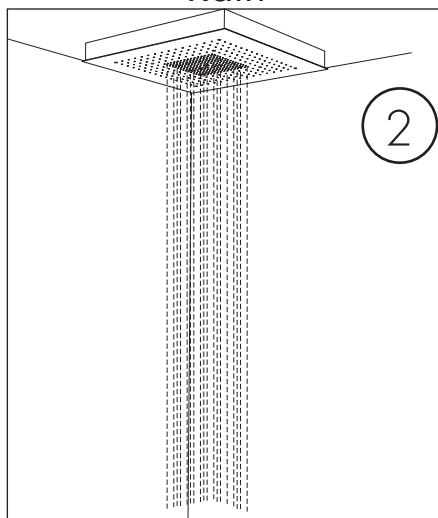
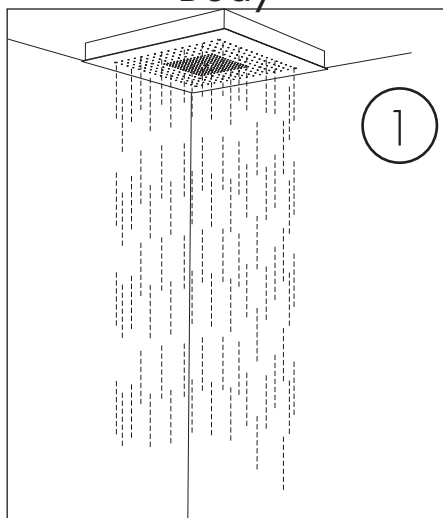

Rain + Body

Rain + Laminar

Body + Laminar

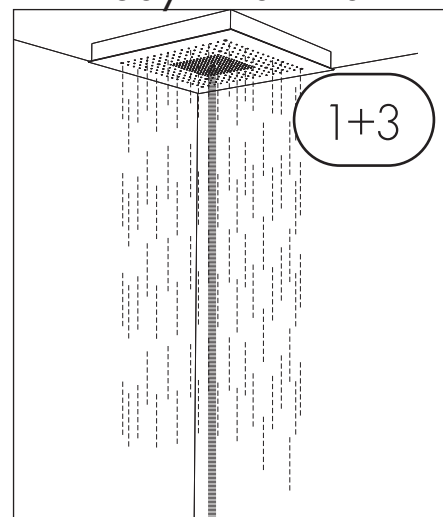
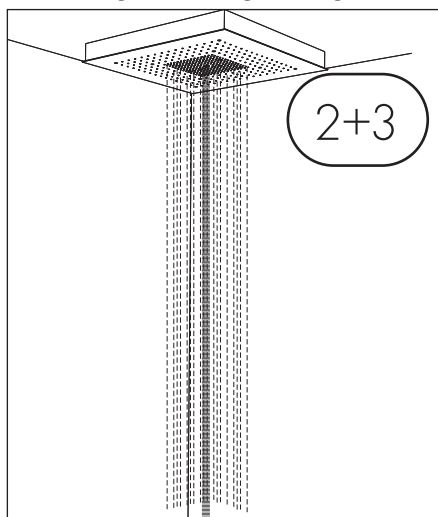
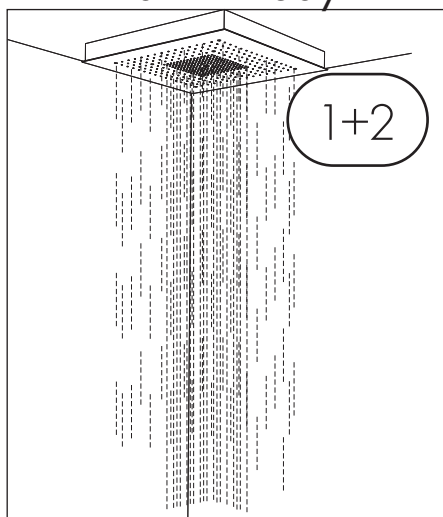



# AXOR ShowerHeaven 720 3jet

10625800 / 10627800

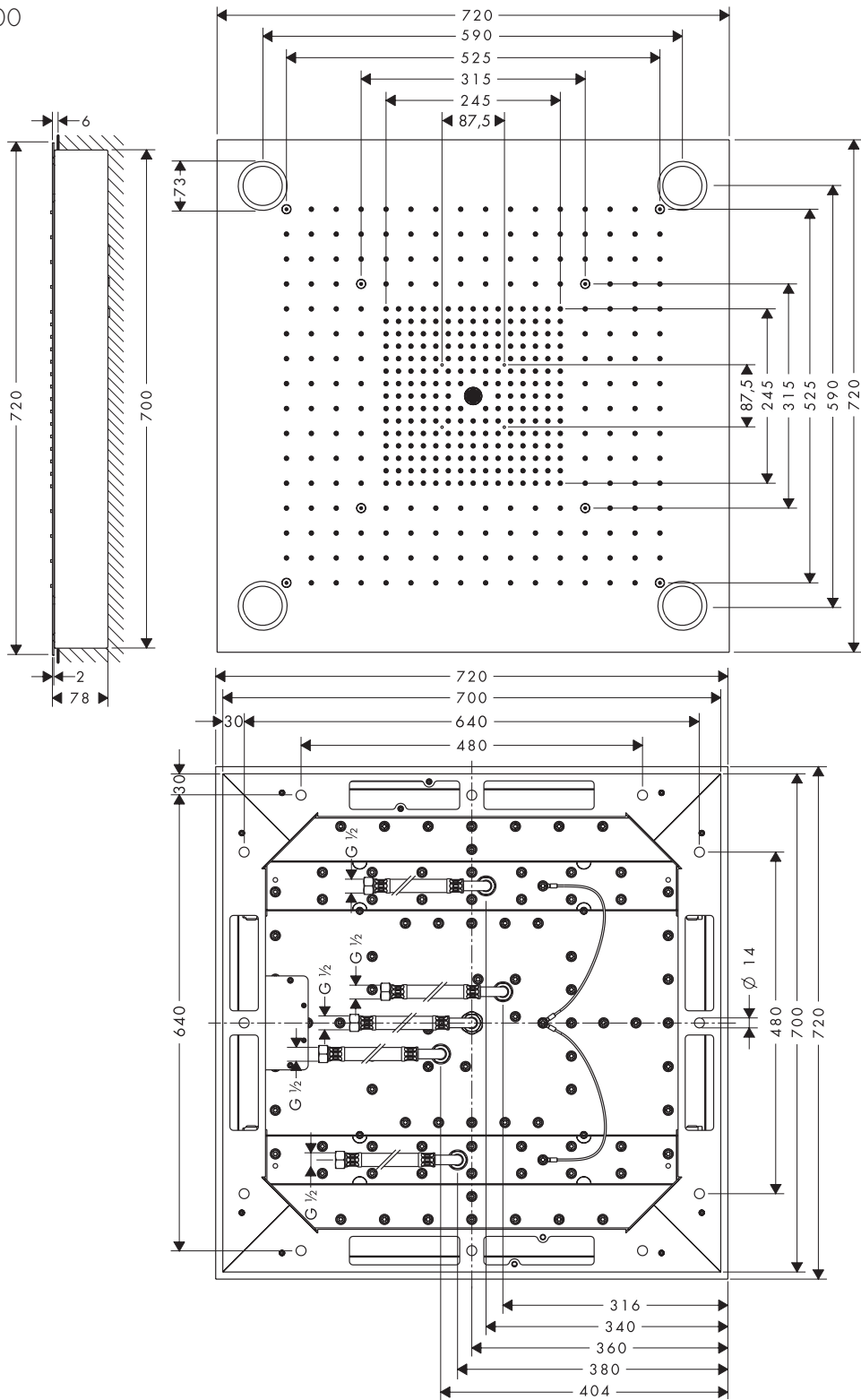



AXOR ShowerHeaven 970 3jet  
10621800 / 10623800

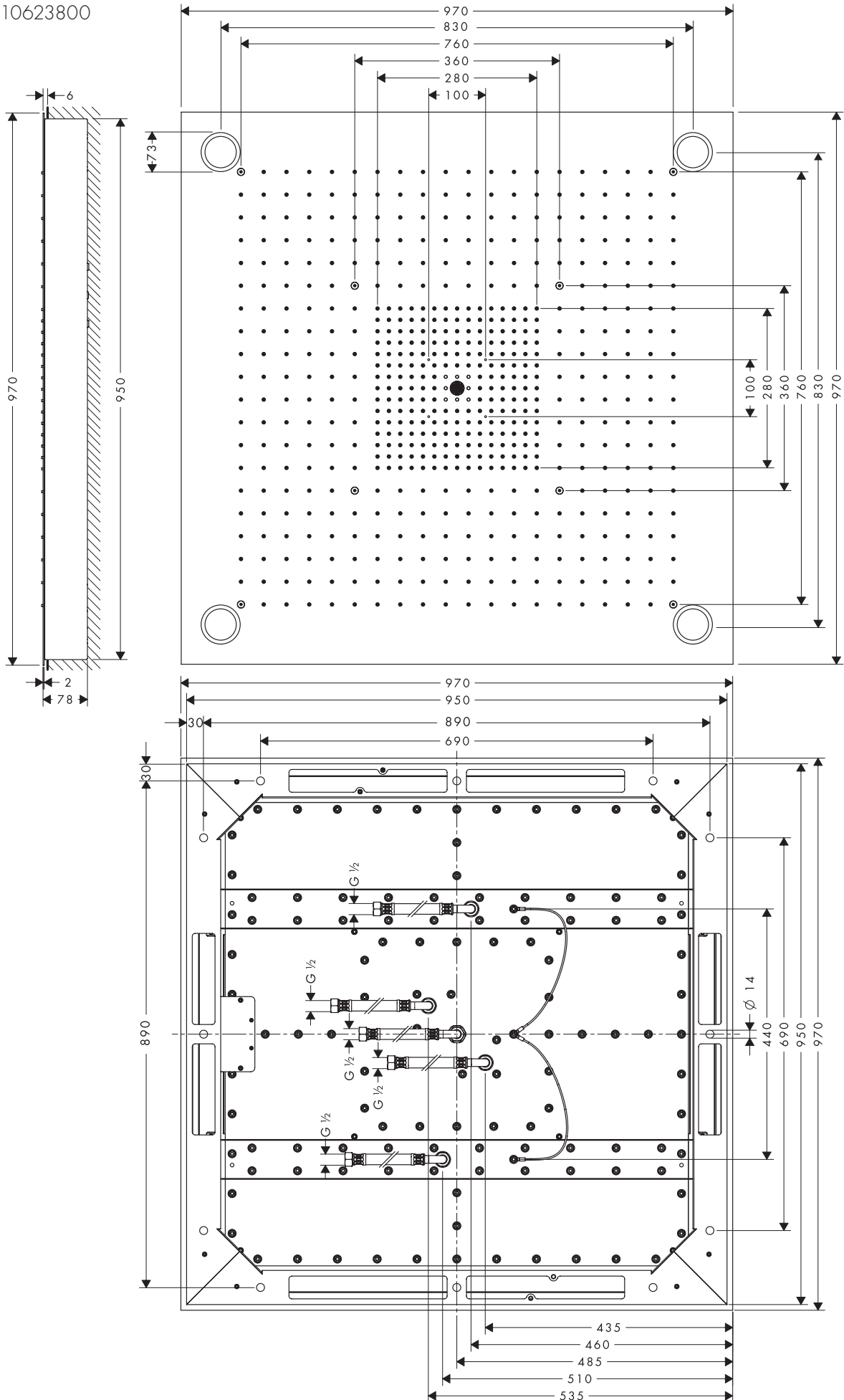





AXOR ShowerHeaven 970 3jet  
10621800

AXOR ShowerHeaven 720 3jet  
10625800

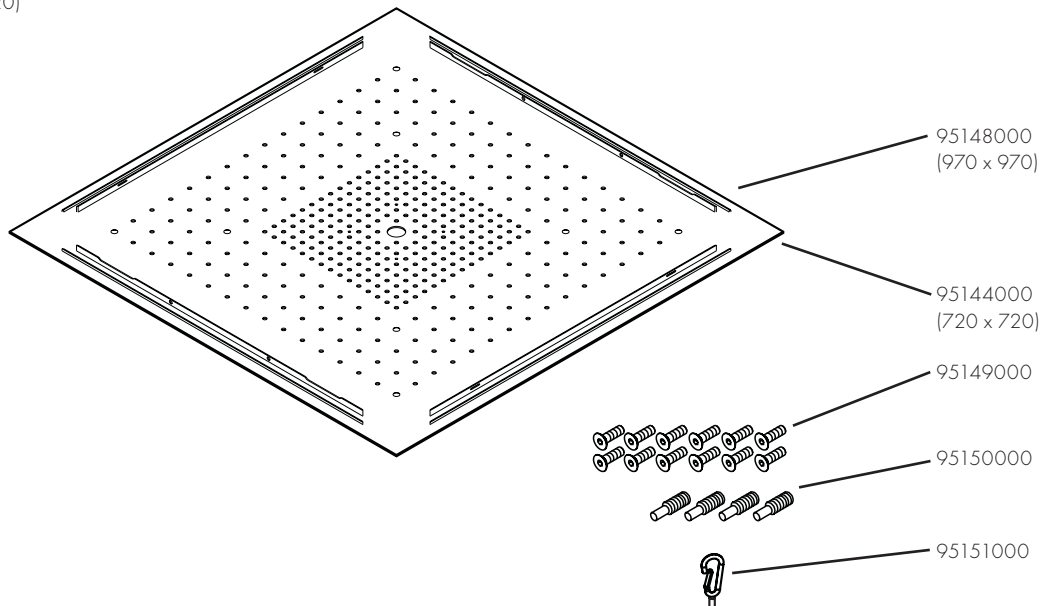
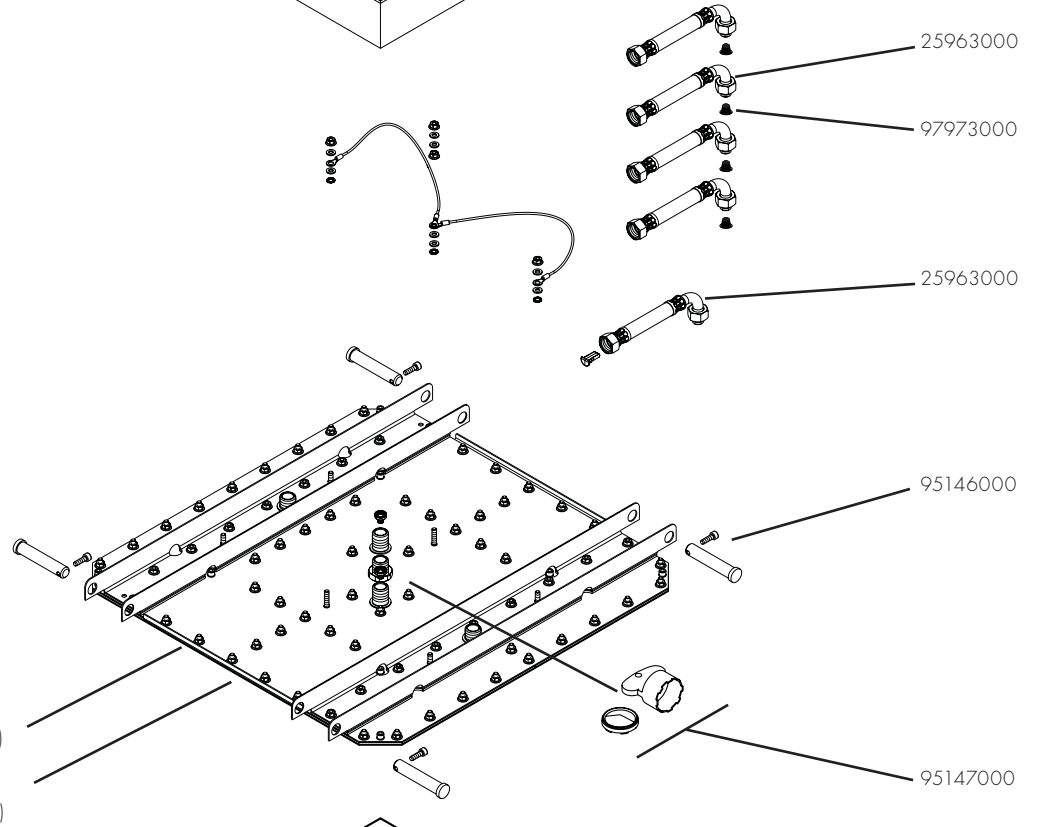
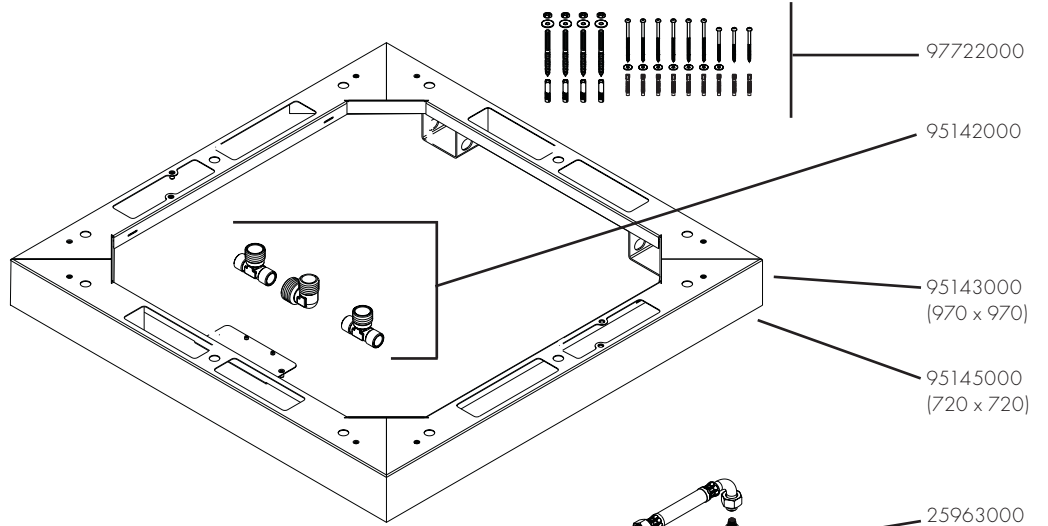



AXOR ShowerHeaven 970 3jet

10623800

AXOR ShowerHeaven 720 3jet

10627800

**AXOR**  
hansgrohe

D-77761 Schiltach / Avestr. 5-9

Produkt: Starck Shower Heaven

Produkt-Nr.:  
Serien-Nr.:

100-240V AC 50-60Hz  
max. 18W IPX5  
max. 0,6MPa (6bar)  
SVGW UD  
4 x 4W (Produkt-Nr.: 30435510)

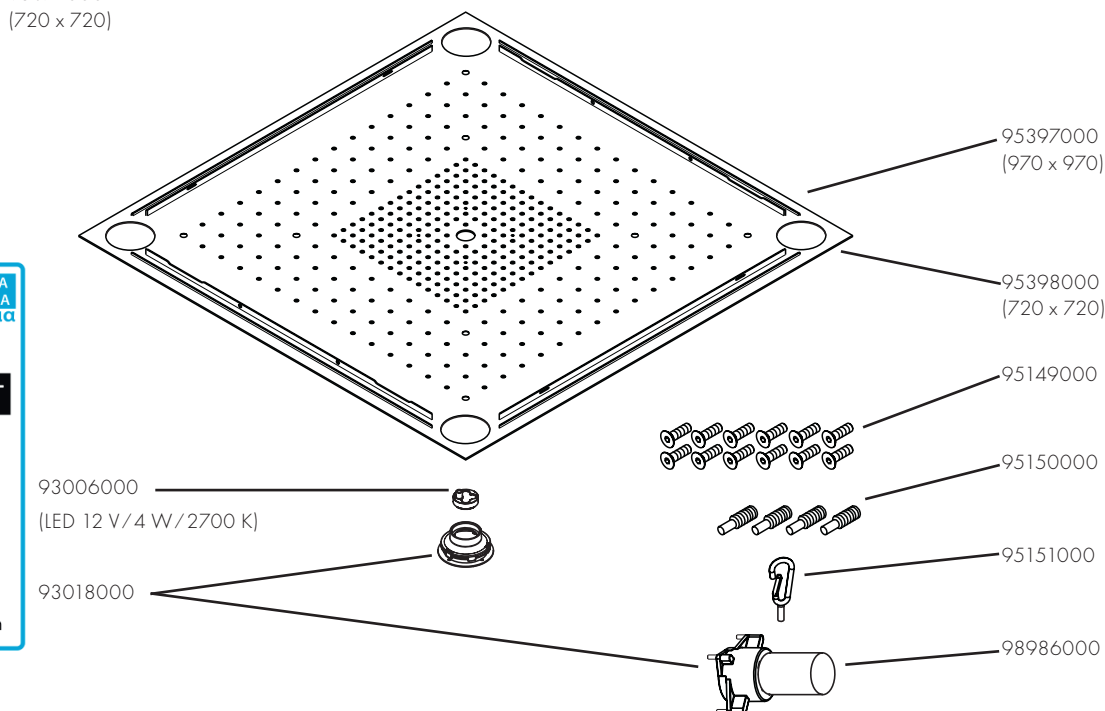
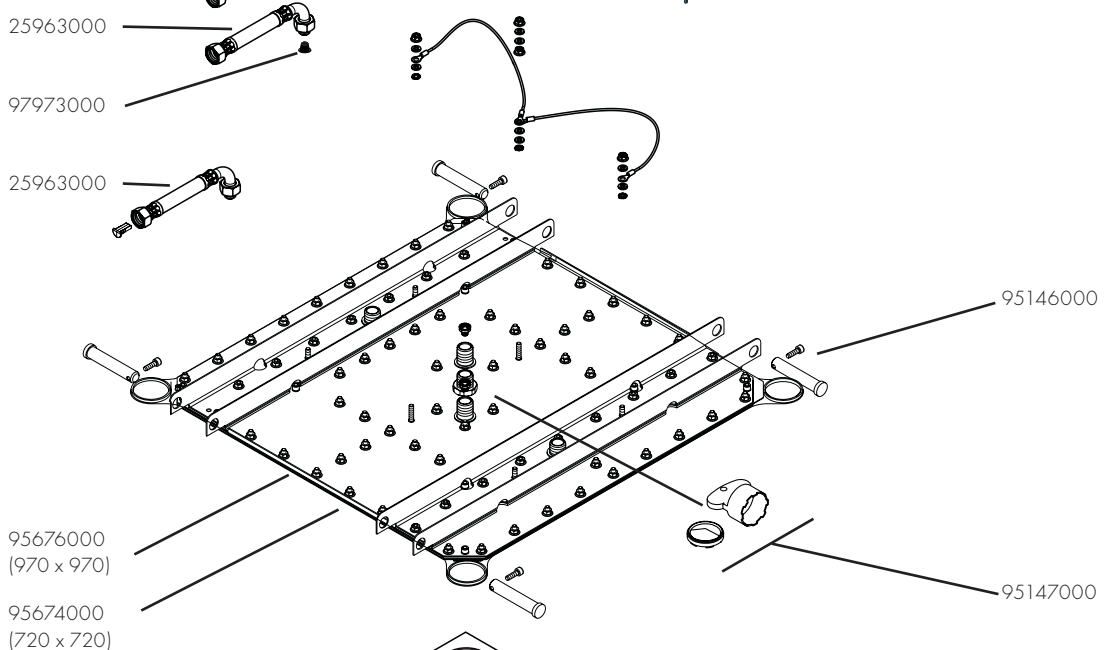
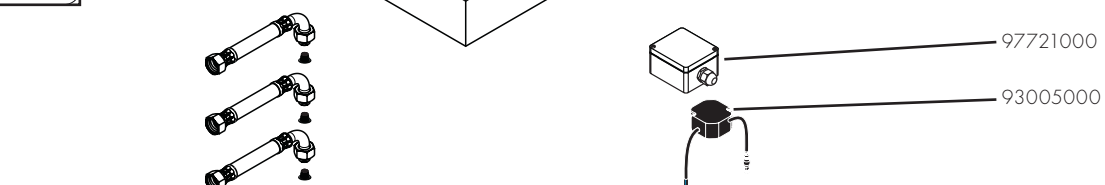
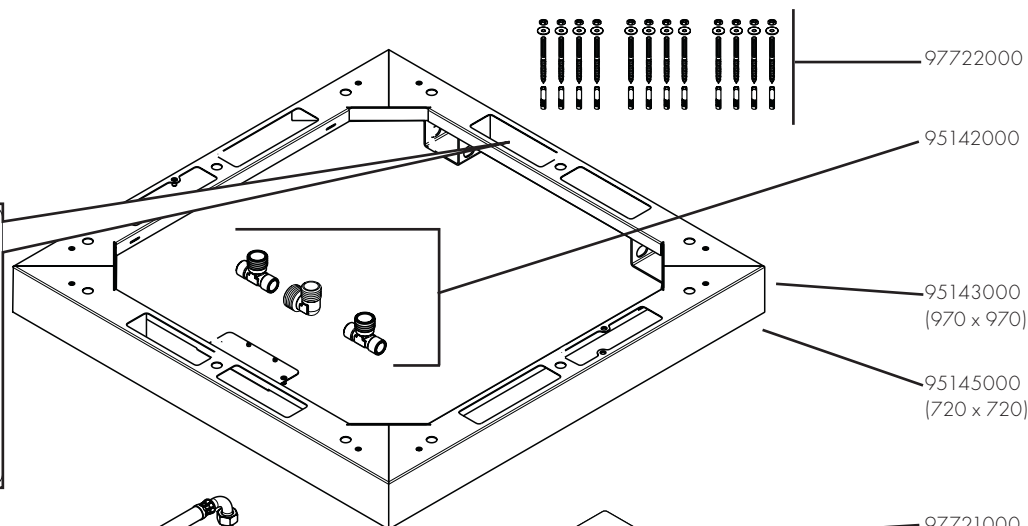

**ENERGY** YIJA IE IA  
енергия · енергия

A++  
A+ **A+**  
A  
B  
C  
D  
E

4 kWh/1000h

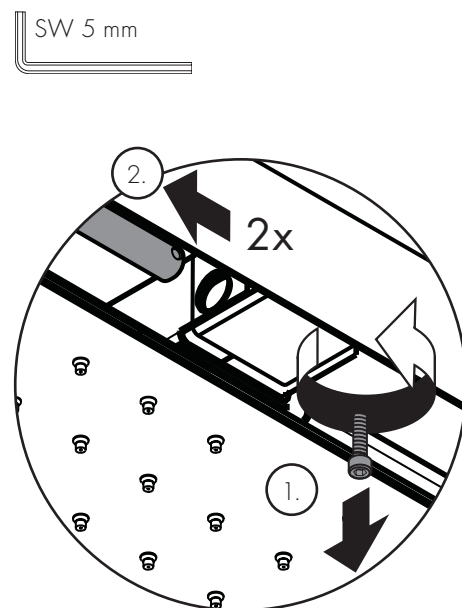
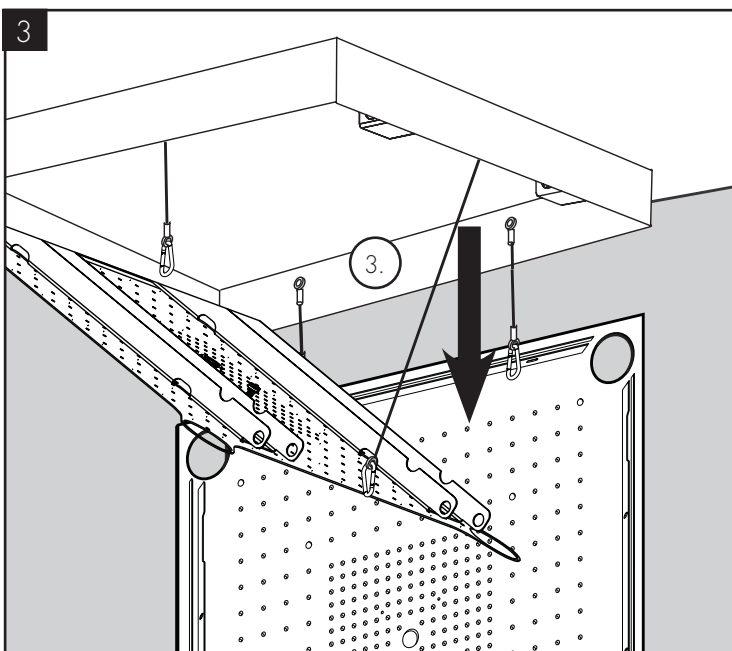
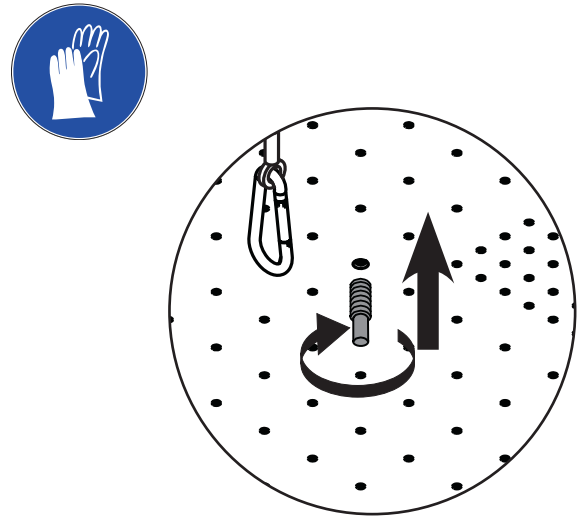
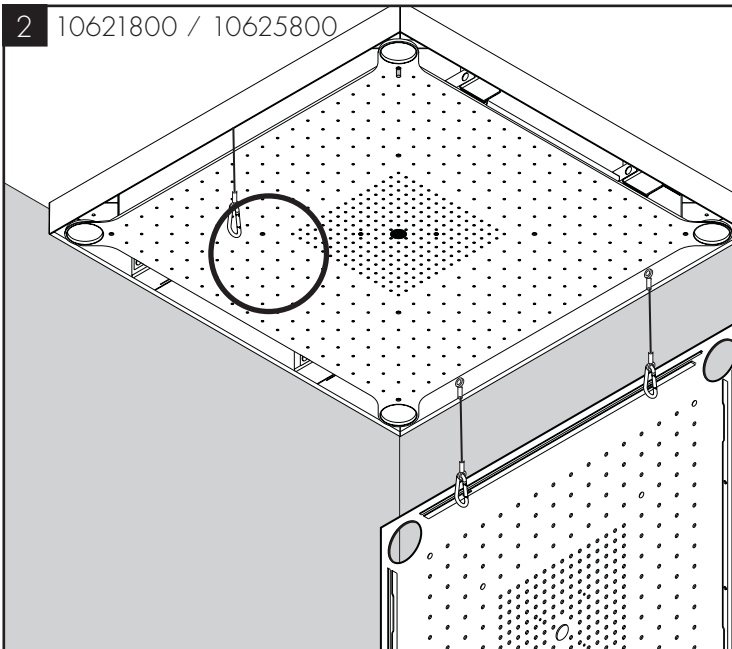
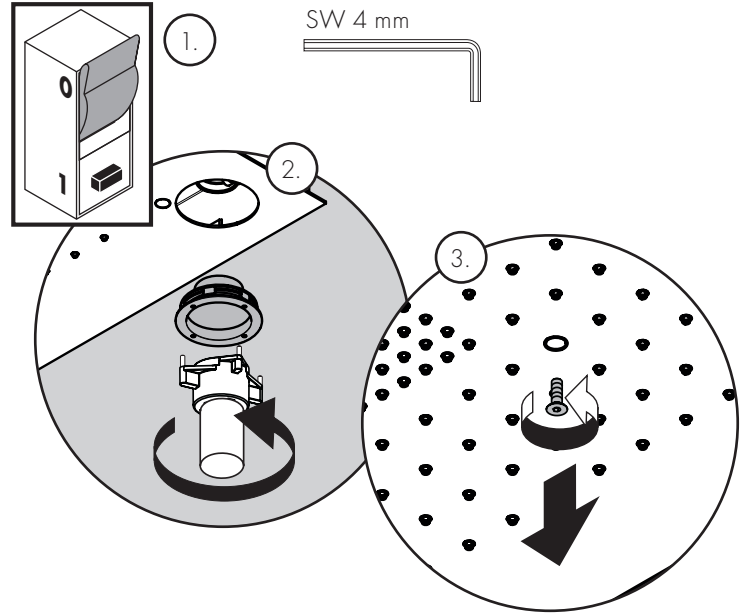
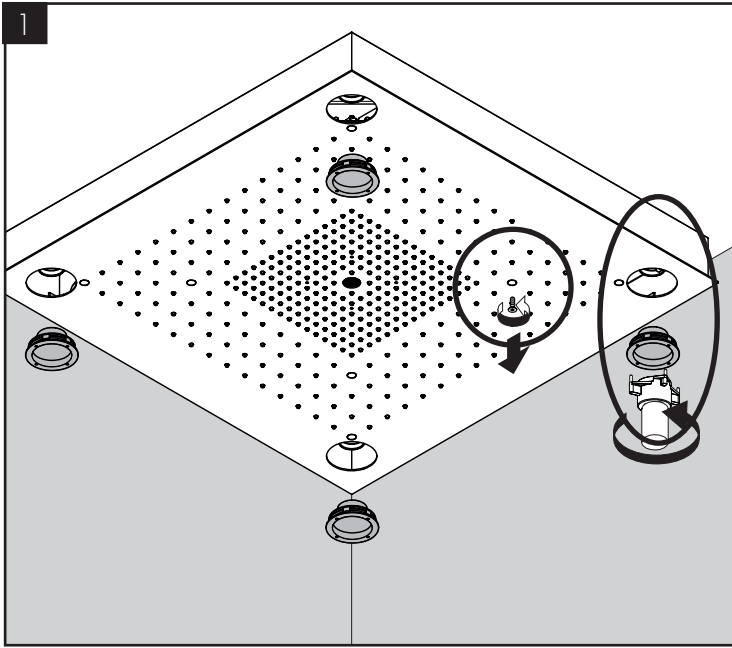

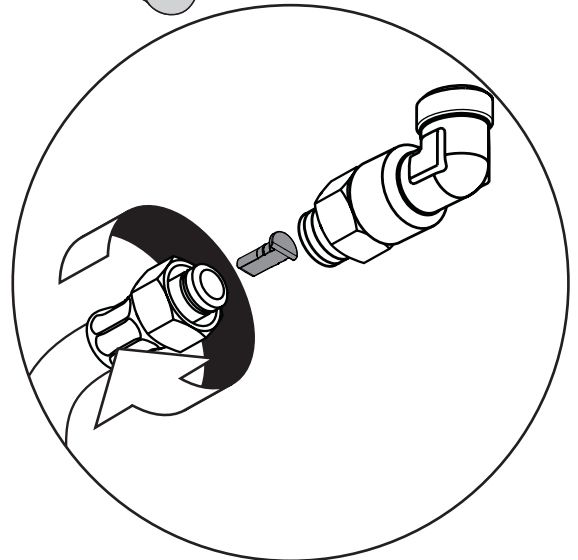
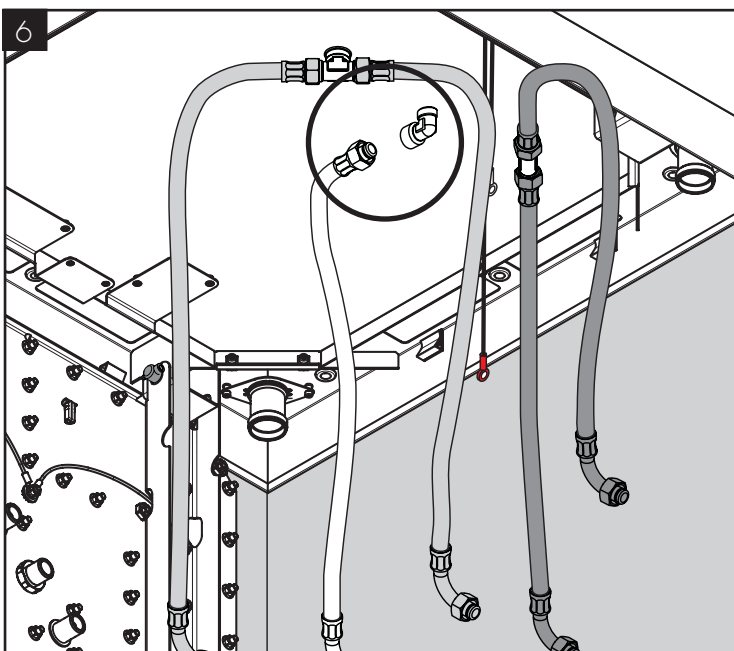
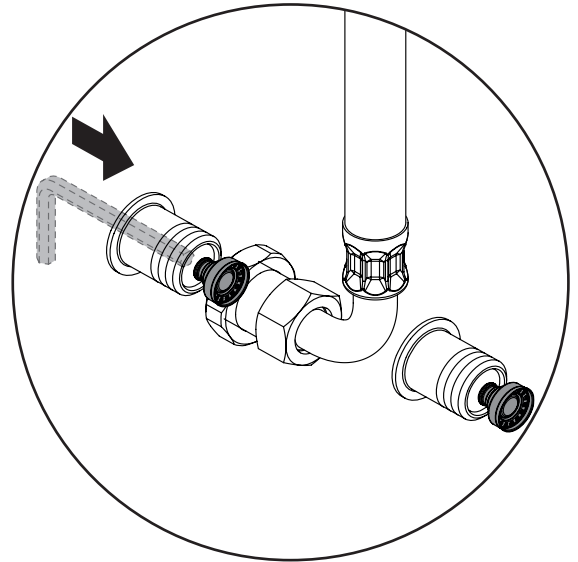
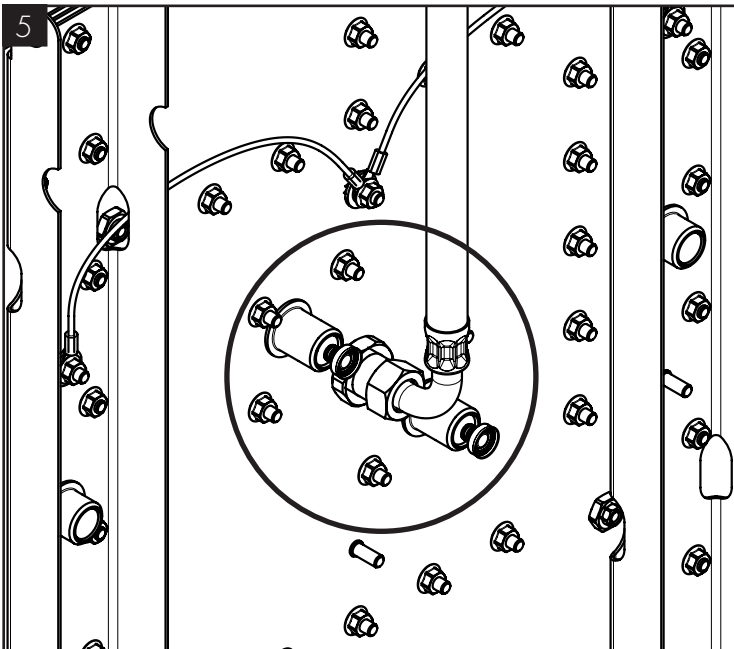
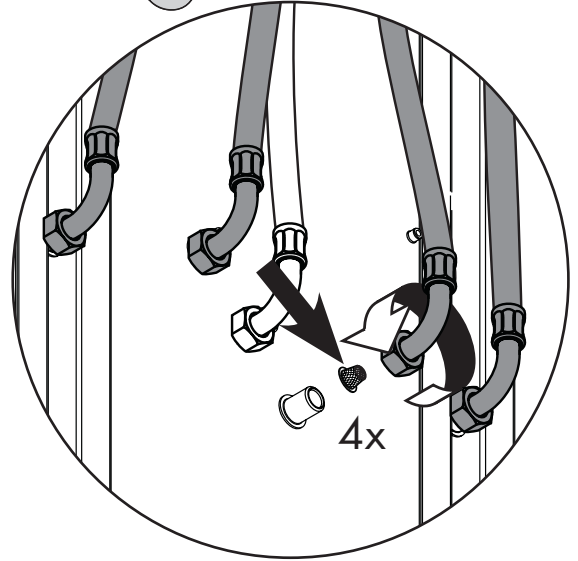
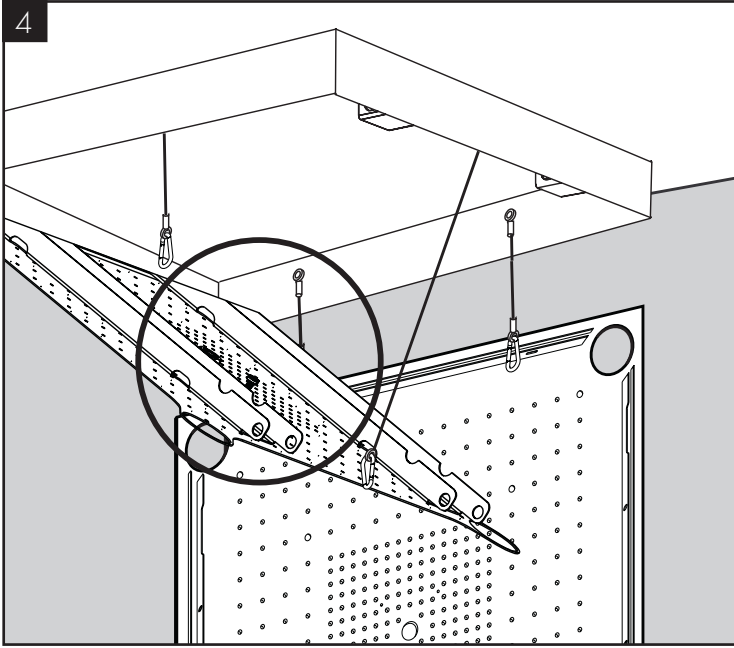

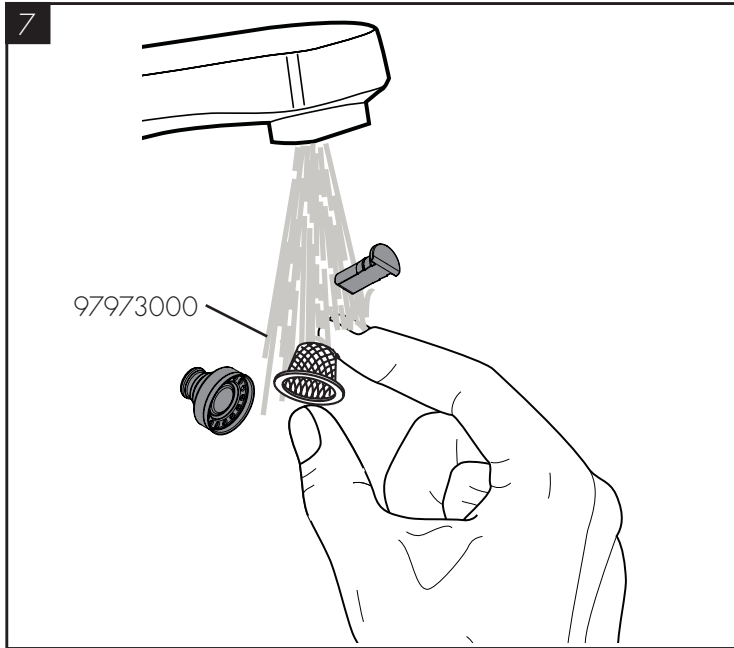

8

DE Montage in umgekehrter Reihenfolge

FR Montage dans le sens inverse

EN Installation in reverse order

IT Montaggio nella successione inversa

ES Montaje en orden inverso

NL Montage in omgekeerde volgorde

DK Montering i omvendt rækkefølge

PT Montagem na ordem inversa

PL Montaż w odwrotnej kolejności

CS Montáž v opačném pořadí

SK Montáž v opačnom poradí

ZH 按相反的顺序进行安装

RU Монтаж выполняется в обратной последовательности

HU Szerelés fordított sorrendben

FI Asennus päinvastaisessa järjestyksessä

SV Montera i omvänd ordningsföljd

LT Montavimas atbuline tvarka

HR Montaža se izvodi obrnutim redoslijedom

TR Montaj ters işlem sırasına göre

RO Montaži în ordine inversă

EL Συναρμολόγηση με την αντίθετη σειρά

SL Montaa v obratnem vrstnem redu

ET Paigaldage vastupidises järjekorras

LV Montāža apgrieztā secībā

SR Montaža se izvodi obrnutim redosledom

NO Monteres i omvendt rekkefølge

BG Монтаж в обратна последователност

SQ Montimi në rend të kundërt

AR ببيترتلا س كعب بيكرتلا

JP 逆向きでの施工

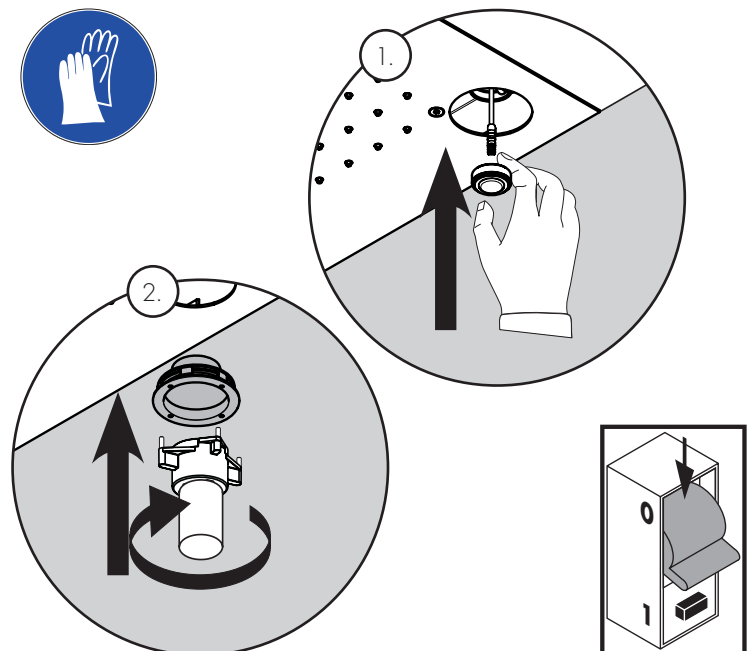
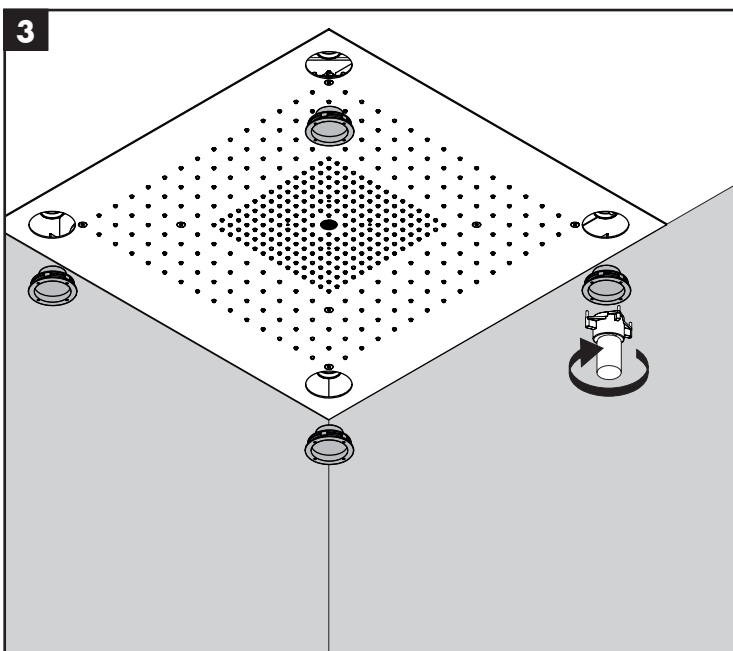
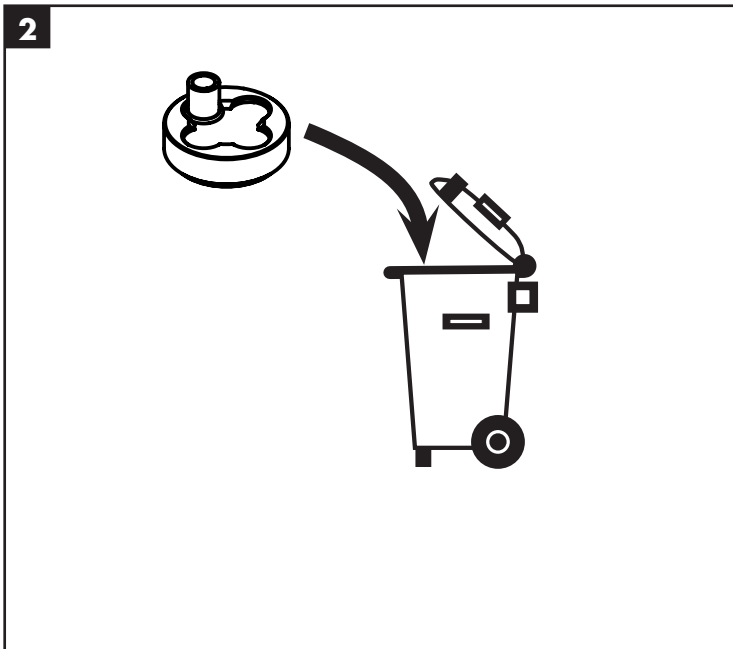
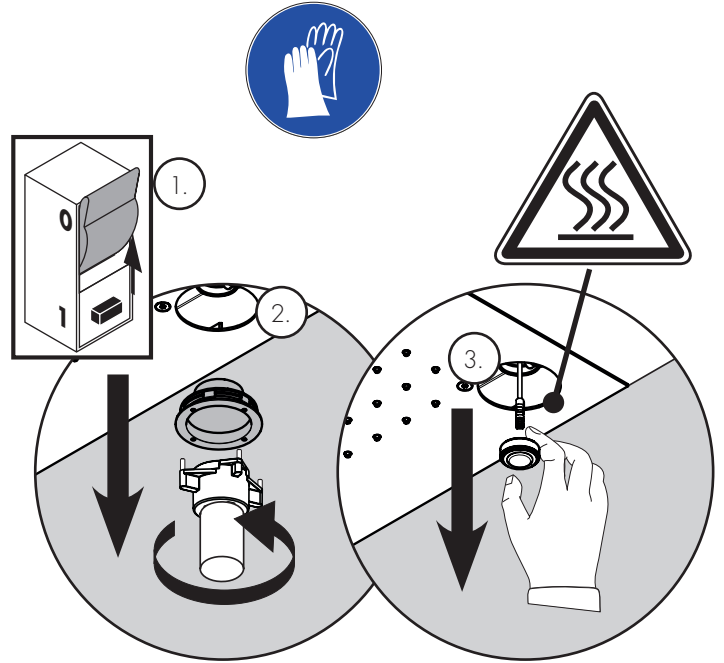
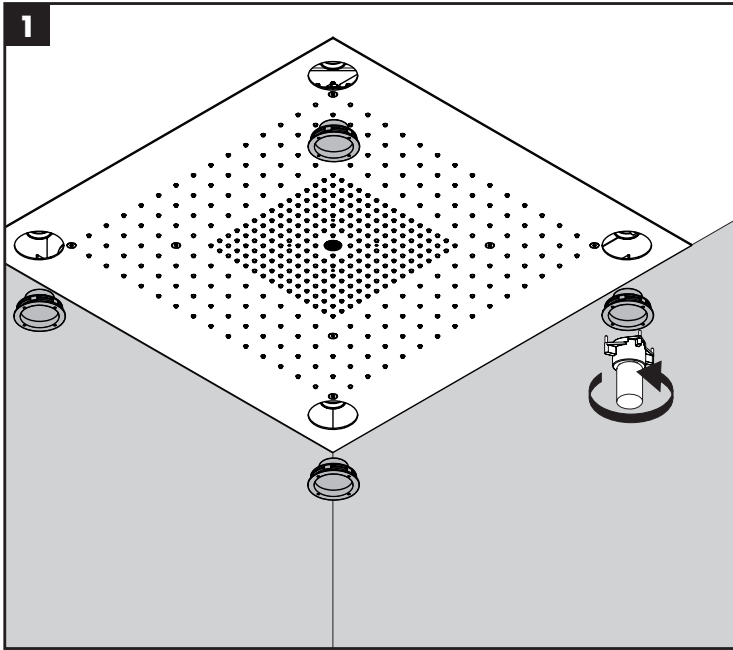



DE / Reinigungsempfehlung / Garantie / Kontakt  
 FR / Recommandation pour le nettoyage / Garanties / Contact  
 EN / Cleaning recommendation / Warranty / Contact  
 IT / Raccomandazione di pulizia / Garanzia / Contatto  
 ES / Recomendaciones para la limpieza / Garantía / Contacto  
 NL / Aanbevelingen inzake reiniging / Garantie / Contact  
 DK / Rensning, anbefaling / Garanti / Kontakt  
 PT / Recomendações de limpeza / Garantia / Contacto  
 PL / Zalecenie dotyczące pielęgnacji / Gwarancja / Kontakt  
 CS / Doporučení k čištění / Závuka / Kontakt  
 SK / Odporúčania pre čistenie / Závuka / Kontakt  
 ZH / 清洁指南 / 担保 / 接触  
 RU / Рекомендации по очистке / Гарантии / Контакты  
 FI / Puhdistussuositus / Takuu / Kosketus  
 SV / Rengöringsrekommendationer / Garanti / Contacto  
 LT / Valymo rekomendacijos / Garantija / Kontaktai  
 HR / Preporuke za čišćenje / Garancija / Kontakt  
 TR / Temizleme önerisi / Garanti / Temas  
 RO / Recomandări pentru curățare / Garanție / Contact  
 EL / Σύσταση καθαρισμού / Εγγύηση / επαφή  
 SL / Priporočilo za čiščenje / Garancija / Kontakt  
 ET / Puhastussuositused / Garantii / Kontakt  
 LV / Tīrīšanas ieteikumi / Garantija / Kontakti  
 SR / Preporuke za čišćenje / Garancija / Kontakt  
 NO / Anbefaling for rengjøring / Garanti / Kontakt  
 BG / Препоръка за почистване / Гаранция / Контакт  
 SQ / Këshilla rreth pastrimit / Garancia / Kontakt  
 KO / 세정시 권장사항 / 품질보증 / 접촉  
 AR / توصيات التنظيف / الضمان (الولايات المتحدة الأمريكية) / اتصال  
 HU / Tisztítási tanácsok / Garancia / érintkezés  
 JP / お手入れの方法 / 保証について / ご連絡先



[www.axor-design.com/  
cleaning-recommendation](http://www.axor-design.com/cleaning-recommendation)

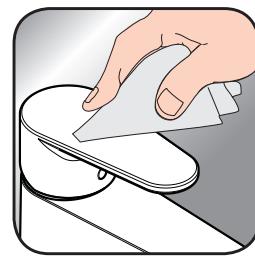

[www.axor-design.com/  
cleaning-recommendation](http://www.axor-design.com/cleaning-recommendation)



[www.axor-design.com/  
cleaning-recommendation](http://www.axor-design.com/cleaning-recommendation)



[www.axor-design.com/  
cleaning-recommendation](http://www.axor-design.com/cleaning-recommendation)

DE / Einfach sauber: Kalk lässt sich von den Noppen ganz leicht abrubbeln.  
 FR / La propreté en toute simplicité: les dépôts formés sur les buses élastiques en silicone s'éliminent par un simple passage de la main.  
 EN / Just clean: simply rub over the spray nozzles to remove lime scale.  
 IT / Facile da pulire: Il calcare viene eliminato semplicemente dagli ugelli elastici in silicone.  
 ES / Fácil aseo: La cal se puede retirar sencillamente frotando con los dedos de las toberas elásticas de silicona.  
 NL / Eenvoudig schoon: Kalk kan eenvoudig van de noppen worden gewreven.  
 DK / Enkel rengøring: Det er let at fjerne kalkaflejringer fra stråledyserne.  
 PT / Simplesmente limpo: o calcário pode ser simplesmente retirado das saliências através de fricção.  
 PL / Po prostu czysto: Pęczki można całkiem łatwo oczyścić z kamienia.  
 CS / Jednoduše čistě: Vapenné usazeniny můžete z nopků snadno odstranit oříením.  
 SK / Jednoducho čistý: Vodný kameň sa dá zo štetín celkom ľahko odstrániť.  
 ZH / 清洁: 只需要揉搓花洒表面的出水孔即可去除水垢。  
 RU / Простота чистки: известь очень легко стирается с утолщений.  
 FI / Yksinkertaisesti puhdas: kalkin voi helposti hieroa irti nypystistä.  
 SV / Enkelt att göra rent: det är lätt att ta bort kalk från nopporna.  
 LT / Paprasta švara: kalkės lengvai nugrandomos nuo kilpos.  
 HR / Jednostavno čisto: Kamenac se sasvim lako uklanja s izbočina.  
 TR / Sadece temiz: Kireç, düğümlemlerle kolayca ovalanabilir.  
 RO / Pur și simplu curat: Calcarul se îndepărtează ușor de pe noduri prin frecare.  
 EL / Απλά τέλεια καθαριότητα: Τα άλατα μπορούν να αφαιρεθούν με μεγάλη ευκολία από τα στόμια.  
 SL / Preprosto čisto: apnenec se z lahkoto podrgne z vozličkov.  
 ET / Lihtsalt puhas: lujja saab nuppuheld lihtsalt maha hõõruda.  
 LV / Vienkārša tīrīšana: kaļķis no izvīrzījumiem ir viegli norubināms.  
 SR / Jednostavno čisto: Kamenac se sasvim lako skida sa izbočina.  
 NO / Simpelten ren: Ved å gnikke er det lett å fjerne kalk fra nuppene.  
 BG / Просто чисто: Варовикът лесно може да се изтръси от удебеленията.  
 SQ / Thjesht dhe pastër. Mbetjet gëlqerore mund të hiqen me fërkim të lehtë.  
 AR / إنه سهل التنظيف، حيث يسقط الجير بسهولة شديدة من الأجزاء الناعمة  
 HU / Egyszerűen tiszta: a vízkő egészen könnyen ledörzsölhető a csomókról.  
 JP / 清掃が簡単: カルキは突起部から簡単にこすり落とすことができます。

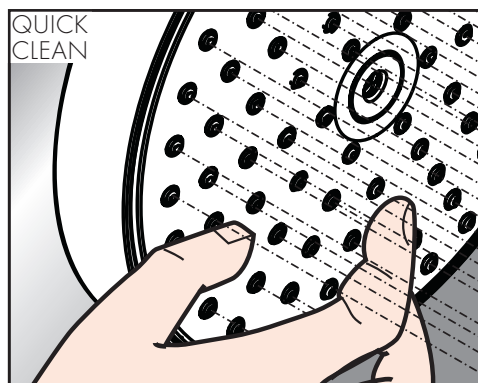

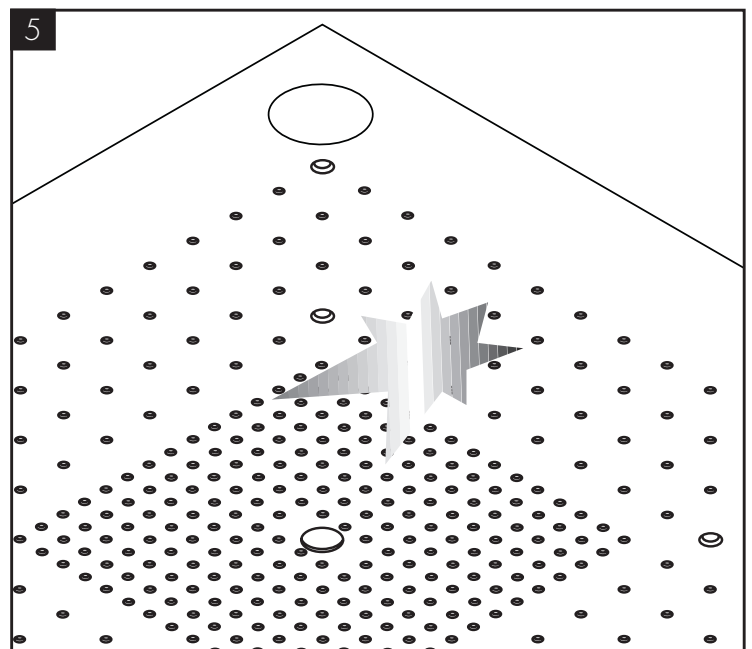
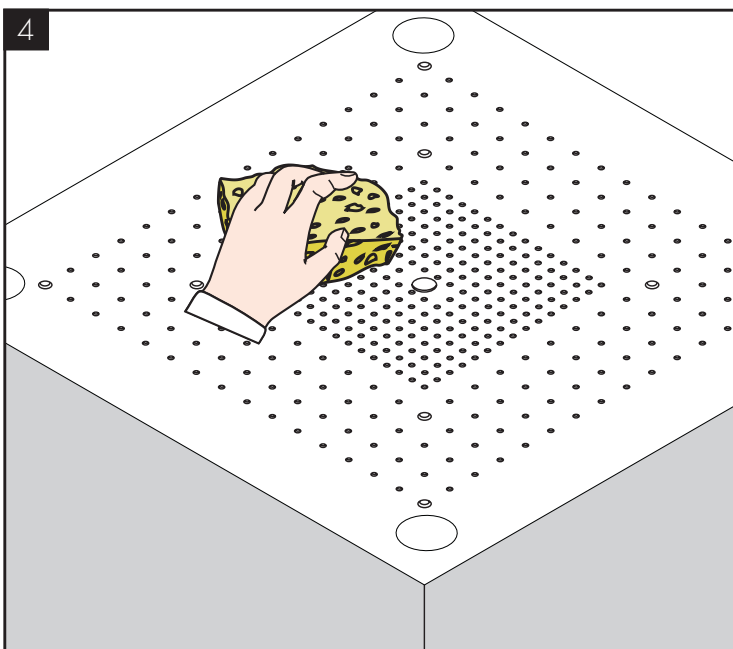
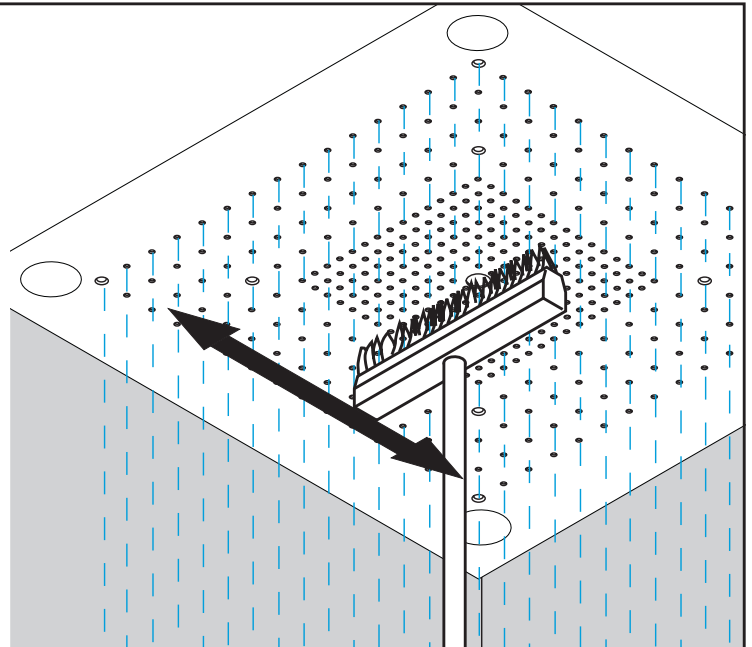
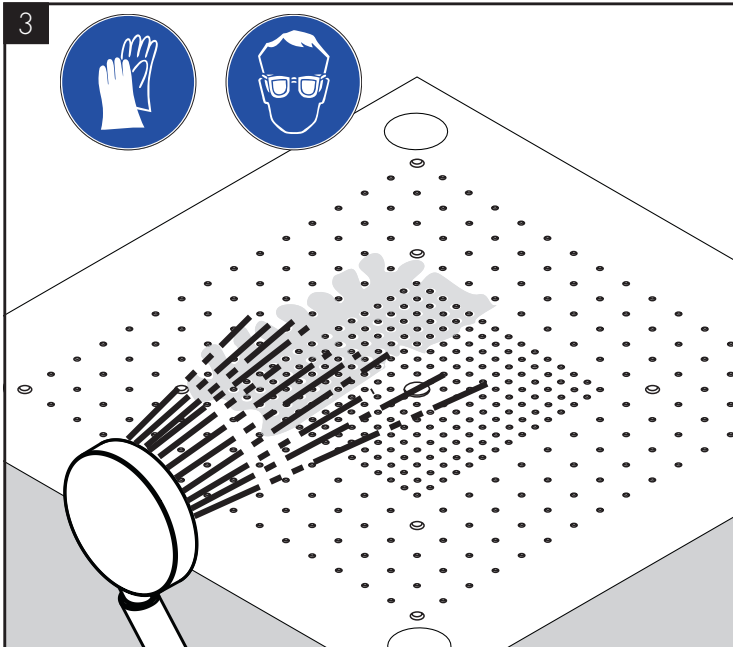
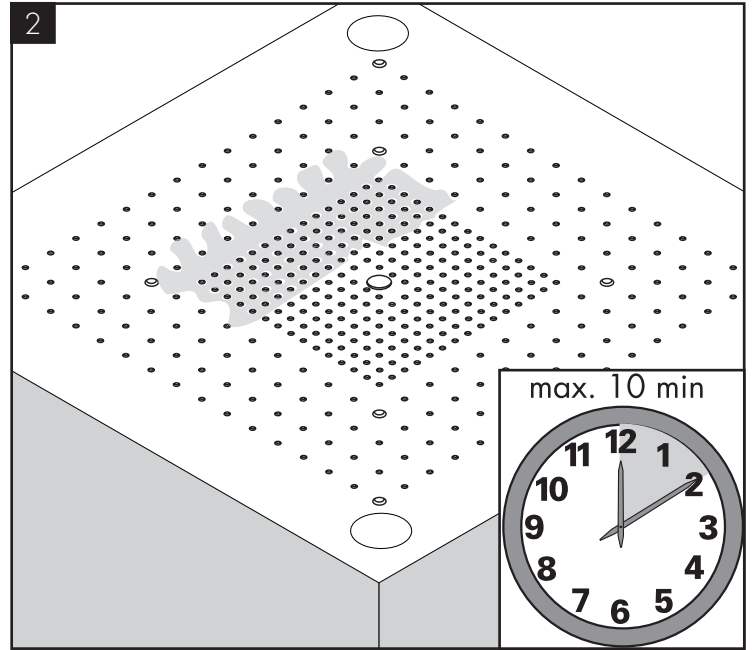
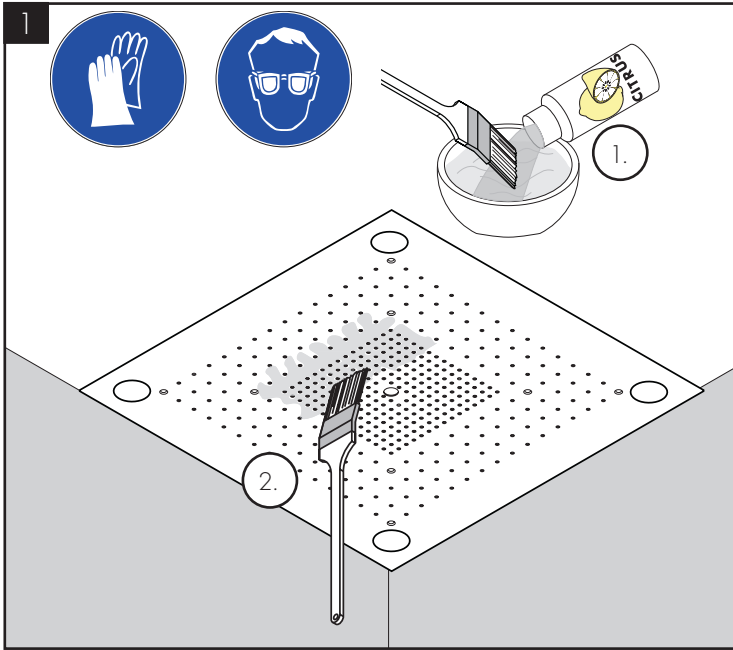



# AXOR

**hansgrohe**  
10623800, 10627800

 Diese Leuchte ist geeignet für Leuchtmittel der



Diese Leuchte wird verkauft mit einem Leuchtmittel der Energieklasse: 

**874/2012** 

- FR Ce luminaire est compatible avec des ampoules des classes énergétiques: A+  
Le luminaire est vendu avec une ampoule de la classe énergétique: A+
- EN This light fitting is compatible with bulbs from energy classes: A+  
The light fitting is sold with a bulb from energy class: A+
- IT Questo dispositivo è compatibile con lampadine di classi energetiche: A+  
Il dispositivo è venduto con una lampadina di classe energetica: A+
- ES Esta luminaria es compatible con bombillas de las clases energéticas: A+  
Esta luminaria se vende con una bombilla de la clase energética: A+
- NL In deze armatuur passen lampen met energieklassen: A+  
De armatuur wordt verkocht met een lamp met energieklassen: A+
- DK I denne lampe kan anvendes pærer i energiklasse: A+  
Denne lampe sælges med en pære i energiklasse: A+
- PT Candeeiro compatível com lâmpadas das classes energéticas: A+  
Inclui uma lâmpada da classe energética: A+
- PL Oprawa jest przystosowana do żarówek o klasach energetycznych: A+  
Oprawę sprzedaje się z żarówką o klasie energetycznej: A+
- CS Toto svítidlo je kompatibilní se žárovkami energetických tříd: A+  
Toto svítidlo se prodává se žárovkou energetické třídy: A+
- SK Toto svietidlo je kompatibilné so žiarovkami energetických tried: A+  
Toto svietidlo sa predáva so žiarovkou energetickej triedy: A+
- HU A lámpatest a következő energiasztályú égőkkel működik: A+  
A lámpatesttel együtt eladott égő energiasztálya: A+
- FI Valaisimessa voidaan käyttää seuraaviin energialuokkiin kuuluvia lamppuja: A+  
Valaisimen mukana toimitettavan lampun energialuokka: A+
- SV I denna ljusarmatur kan lampor av följande energiklasser användas: A+  
Denna ljusarmatur säljs med en lampa i energiklass: A+
- LT Šviestuvą galima naudoti su šių energijos klasių lemputėmis: A+  
Šviestuvą parduodamas su lempute, kurios energijos klasė yra: A+
- HR Ovo rasvjetno tijelo kompatibilno je sa žaruljama ovog energetskog razreda: A+  
Rasvjetno tijelo se prodaje sa žaruljama ovog energetskog razreda: A+
- RO Acest corp de iluminat este compatibil cu becurile din clasele energetice: A+  
Acest corp de iluminat este vândut cu un bec din clasa energetică: A+
- EL Το Φωτιστικό αυτό είναι συμβατό με λαμπτήρες ενεργειακής τάξης: A+  
Το Φωτιστικό αυτό πωλείται με λαμπτήρα ενεργειακής τάξης: A+
- SL Ta svetilka je združljiva s sijalkami naslednjih energijskih razredov: A+  
Ta svetilka se prodaja s sijalko energijskega razreda: A+
- ET Sellesse valgustisse saab panna järgmistele energiklasside lampe: A+  
Seda valgustit müüakse koos lambiga, mille energiklass on: A+
- LV Šis gaismeklis ir saderīgs ar šādu energoefektivitātes klašu spuldzēm: A+  
Šo gaismekli pārdod ar šādas energoefektivitātes klases spuldzi: A+
- BG това осветително тяло е съвместимо с крушките от енергийни класове: A+  
това осветително тяло се продава с крушка от енергиен клас: A+

AXOR / Hansgrohe SE  
Auestraße 5-9  
77761 Schiltach  
Deutschland

info@axor-design.com  
axor-design.com