

DE	Gebrauchsanleitung / Montageanleitung	2
FR	Mode d'emploi / Instructions de montage	2
EN	Instructions for use / assembly instructions	3
IT	Istruzioni per l'uso / Istruzioni per Installazione	3
ES	Modo de empleo / Instrucciones de montaje	4
NL	Gebruiksaanwijzing / Handleiding	4
DK	Brugsanvisning / Monteringsvejledning	5
PT	Instruções para uso / Manual de Instalação	5
PL	Instrukcja obsługi / Instrukcja montażu	6
CS	Návod k použití / Montážní návod	6
SK	Návod na použitie / Montážny návod	7
ZH	用户手册 / 组装说明	7
RU	Руководство пользователя / Инструкция по монтажу	8
HU	Használati útmutató / Szerelési útmutató	8
FI	Käyttöohje / Asennusohje	9
SV	Brugsanvisning / Monteringsanvisning	9
LT	Vartotojo instrukcija / Montavimo instrukcijos	10
HR	Upute za uporabu / Uputstva za instalaciju	10
TR	Kullanım kılavuzu / Montaj kılavuzu	11
RO	Manual de utilizare / Instrucțiuni de montare	11
EL	Οδηγίες χρήσης / Οδηγία συναρμολόγησης	12
SL	Navodilo za uporabo / Navodila za montažo	12
ET	Kasutusjuhend / Paigaldusjuhend	13
LV	Lietošanas pamācība / Montāžas instrukcija	13
SR	Uputstvo za upotrebu / Uputstvo za montažu	14
NO	Brugsanvisning / Montasjeveiledning	14
BG	Инструкция за употреба / Ръководство за монтаж	15
SQ	Udhëzuesi i përdorimit / Udhëzime rreth montimit	15
AR	دليل الاستخدام / تعليمات التجميع	16

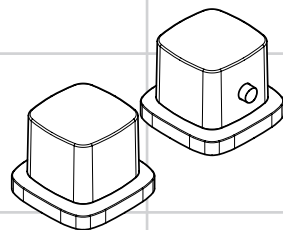

PuraVida

15474000 / 15474400



Ihr Online-Fachhändler für:

hansgrohe

- Kostenlose und individuelle Beratung
- Hochwertige Produkte
- Kostenloser und schneller Versand

- TOP Bewertungen
- Exzelerter Kundenservice
- Über 20 Jahre Erfahrung



E-Mail: info@unidomo.de | Tel.: 04621 - 30 60 89 0 | www.unidomo.de



Sicherheitshinweise

- Bei der Montage müssen zur Vermeidung von Quetsch- und Schnittverletzungen Handschuhe getragen werden.

Montagehinweise

- Vor der Montage muss das Produkt auf Transportschäden untersucht werden. Nach dem Einbau werden keine Transport- oder Oberflächenschäden anerkannt.
- Die Leitungen und die Armatur müssen nach den gültigen Normen montiert, gespült und geprüft werden.
- Die in den Ländern jeweils gültigen Installationsrichtlinien sind einzuhalten.

Symbolerklärung



Kein essigsäurehaltiges Silikon verwenden!

max. Safety Function (siehe Seite 20)
≈ 42 °C

Dank der Safety Function lässt sich die gewünschte Höchsttemperatur von z. B. max. 42 °C voreinstellen.



Maße (siehe Seite 17)



Serviceteile (siehe Seite 17)

XXX = Farbcodierung

000 = chrom
400 = weiß/chrom



Bedienung (siehe Seite 22)



Reinigung

siehe beiliegende Broschüre.



Prüfzeichen (siehe Seite 24)

Consignes de sécurité

- Lors du montage, porter des gants de protection pour éviter toute blessure par écrasement ou coupure.

Instructions pour le montage

- Avant son montage, s'assurer que le produit n'a subi aucun dommage pendant le transport. Après le montage, tout dommage de transport ou de surface ne pourra pas être reconnu.
- Les conduites et la robinetterie doivent être montés, rincés et contrôlés selon les normes en vigueur.
- Les directives d'installation en vigueur dans le pays concerné doivent être respectées.

Description du symbole



Ne pas utiliser de silicone contenant de l'acide acétique!

max. Safety Function (voir pages 20)
≈ 42 °C

Grâce à la fonction Safety, il est possible de prérégler la température maximale par exemple max. 42° C souhaitée.



Dimensions (voir pages 17)



Pièces détachées (voir pages 17)

XXX = Couleurs

000 = chromé
400 = blanc/chromé



Instructions de service
(voir pages 22)



Nettoyage

voir la brochure ci-jointe.



Classification acoustique et débit (voir pages 24)





Safety Notes

- △ Gloves should be worn during installation to prevent crushing and cutting injuries.

Installation Instructions

- Prior to installation, inspect the product for transport damages. After it has been installed, no transport or surface damage will be honoured.
- The pipes and the fixture must be installed, flushed and tested as per the applicable standards.
- The plumbing codes applicable in the respective countries must be observed.

Symbol description



Do not use silicone containing acetic acid!

max. Safety Function (see page 20)

≈ 42° C

The desired maximum temperature for example max. 42° C can be pre-set thanks to the safety function.



Dimensions (see page 17)



Spare parts (see page 17)

XXX = Colors

000 = chrome plated

400 = white/chrome plated



Operation (see page 22)



Cleaning

see enclosed brochure.



Test certificate (see page 24)

Indicazioni sulla sicurezza

- △ Durante il montaggio, per evitare ferite da schiacciamento e da taglio bisogna indossare guanti protettivi.

Istruzioni per il montaggio

- Prima del montaggio è necessario controllare che non ci siano stati danni durante il trasporto. Una volta eseguito il montaggio, non verranno riconosciuti eventuali danni di trasporto o delle superfici.
- Montare, lavare e controllare tubature e rubinetteria rispettando le norme correnti.
- Vanno rispettate le direttive di installazione nazionali vigenti nel rispettivo paese.

Descrizione simbolo



Non utilizzare silicone contenente acido acetico!

max. Safety Function (vedi pagg. 20)

≈ 42° C

Grazie alla funzione antiscottature Safety la temperatura massima per esempio max. 42° C desiderata è facilmente regolabile.



Ingombri (vedi pagg. 17)



Parti di ricambio (vedi pagg. 17)

XXX = Trattamento

000 = cromato

400 = bianco/cromato



Procedura (vedi pagg. 22)



Pulitura

vedi il prospetto accluso.



Segno di verifica (vedi pagg. 24)

Assembly
see page 18



Montaggio
vedi pagg. 18



Indicaciones de seguridad

- ⚠ Durante el montaje deben utilizarse guantes para evitar heridas por aplastamiento o corte.

Indicaciones para el montaje

- Antes del montaje se debe examinarse el producto contra daños de transporte. Después de la instalación no se reconoce ningún daño de transporte o de superficie.
- Los conductos y la grifería deben montarse, lavarse y comprobarse según las normas vigentes.
- Es obligatorio el cumplimiento de las directrices de instalación vigentes en el país respectivo.

Descripción de símbolos



No utilizar silicona que contiene ácido acético!

max. Safety Function (ver página 20)
≈ 42° C

Gracias al tope de temperatura se puede graduar la temperatura máxima por ejemplo max. 42° C.



Dimensiones (ver página 17)



Repuestos (ver página 17)

XXX = Acabados

000 = cromado

400 = blanco/cromado



Manejo (ver página 22)



Limpiar

ver el folleto adjunto.



Marca de verificación

(ver página 24)

Veiligheidsinstructies

- ⚠ Bij de montage moeten ter voorkoming van knel- en snijwonden handschoenen worden gedragen.

Montage-instructies

- Vóór de montage moet het product gecontroleerd worden op transportschade. Na de inbouw wordt geen transport- of oppervlakteschade meer aanvaard.
- De leidingen en armaturen moeten gemonteerd, gespoid en gecontroleerd worden volgens de geldige normen.
- De in de overeenkomstige landen geldende installatie-richtlijnen moeten nageleefd worden.

Symboolbeschrijving



Gebruik geen zuurhoudende silicone!

max. Safety Function (zie blz. 20)
≈ 42° C

Dankzij de Safety Function kan de gewenste maximale temperatuur van bijv. max. 42° C van te voren worden ingesteld.



Maten (zie blz. 17)



Service onderdelen (zie blz. 17)

XXX = Kleuren

000 = verchromd

400 = wit/verchromd



Bediening (zie blz. 22)



Reinigen

zie bijgevoegde brochure.



Keurmerk (zie blz. 24)





Sikkerhedsanvisninger

- ⚠ Ved monteringen skal der bruges handsker for at undgå kvæstelser og snitsår.

Monteringsanvisninger

- Før monteringen skal produktet kontrolleres for transportskader. Efter monteringen godkendes transportskader eller skader på overfladen ikke længere.
- Ledningerne og armaturerne skal monteres, skylles og kontrolleres iht. de gældende standarder.
- Installationsbestemmelserne, der gælder i det enkelte land, skal overholdes.

Symbolbeskrivelse



Der må ikke benyttes eddikesyreholdig silikone!

max. Safety Function (se s. 20)

≈ 42 °C

Takket være Safety varmtvands-begrænsningen kan maksimaltemperaturen forudindstilles eksempel max. 42° C.



Målene (se s. 17)



Reserve dele (se s. 17)

XXX = Overflade

000 = Krom
400 = Hvid/Krom



Brugsanvisning (se s. 22)



Rengøring

se venligst den vedlagte brochure.



Godkendelse (se s. 24)

Avisos de segurança

- ⚠ Durante a montagem devem ser utilizadas luvas de protecção, de modo a evitar ferimentos resultantes de entalamentos e de cortes.

Avisos de montagem

- Antes da montagem deve-se controlar o produto relativamente a danos de transporte. Após a montagem não são aceites quaisquer danos de transporte ou de superfície.
- As tubagens e a torneira têm que ser montadas, enxaguadas e verificadas de acordo com as normas em vigor.
- A prescrições de instalação válidas nos respetivos países devem ser respeitadas.

Descrição do símbolo



Não utilizar silicone que contenha ácido acético!

max. Safety Function (ver página 20)

≈ 42 °C

Grças à função de segurança pode-se regular a temperatura máxima por exemplo max. 42°C.



Medidas (ver página 17)



Peças de substituição

(ver página 17)

XXX = Acabamentos

000 = cromado
400 = branco/cromado



Funcionamento (ver página 22)



Limpeza

consultar a seguinte brochura.



Marca de controlo

(ver página 24)



**! Wskazówki bezpieczeństwa**

- ! Aby uniknąć zranień na skutek zgniecenia lub przecięcia, podczas montażu należy nosić rękawice ochronne.

Wskazówki montażowe

- Przed montażem należy skontrolować produkt pod kątem szkód transportowych. Po montażu nie widać żadnych szkód transportowych ani szkód na powierzchni.
- Przewody i armatura muszą być montowane, płukane i kontrolowane według obowiązujących norm.
- Należy przestrzegać wytycznych instalacyjnych obowiązujących w danym kraju.

Opis symbolu

Nie stosować silikonów zawierających kwas octowy!

max. Safety Function (patrz strona 20)
≈ 42 °C

Dzięki funkcji zabezpieczającej można przestawić żądaną maksymalną temperaturę np. na maks. 42°C.



Wymiary (patrz strona 17)



Części serwisowe (patrz strona 17)

XXX = Kody kolorów

000 = chrom
400 = biały/chrom



Obsługa (patrz strona 22)



Czyszczenie

patrz dołączona broszura.



Znak jakości (patrz strona 24)

! Bezpečnostní pokyny

- ! Pro zabránění řezným zraněním a pohmožděním je nutné při montáži nosit rukavice.

Pokyny k montáži

- Před montáží je třeba produkt zkontrolovat, zda nebyl při transportu poškozen. Po zabudování nebudou uznány žádné škody způsobené transportem nebo poškození povrchu.
- Vedení a armatura musí být namontovány, propláchnuty a otestovány podle platných norem.
- Je třeba dodržovat montážní pravidla platné v dané zemi.

Popis symbolů

Nepoužívat silikon s obsahem kyseliny octové!

max. Safety Function (viz strana 20)
≈ 42 °C

Díky Safety Function je možné předem nastavit nejvyšší požadovanou teplotu, např. max. 42°C.



Rozměry (viz strana 17)



Servisní díly (viz strana 17)

XXX = Kód povrchové úpravy

000 = chrom
400 = bílý/chrom



Ovládání (viz strana 22)



Čištění

viz přiložená brožura.



Zkušební značka (viz strana 24)





Bezpečnostné pokyny

-  Pri montáži musíte nosiť rukavice, aby ste predišli pomliaždeninám a rezným poraneniam.

Pokyny pre montáž

- Pred montážou musíte produkt skontrolovať, či nebol počas transportu poškodený. Po zabudovaní nebudú uznané žiadne škody spôsobené transportom alebo poškodenia povrchu.
- Ledningarna och blandaren måste monteras, spolás igenom och kontrolleras enligt de gällande normerna.
- Je potrebné dodržiavať smernice o inštalácii, ktoré sú práve teraz platné v krajinách.

Popis symbolov



Nepoužívať silikón s obsahom kyseliny octovej!

max. Safety Function (viď strana 20)
≈ 42 °C

Vďaka Safety Function je možné vopred nastaviť najvyššiu požadovanú teplotu, napr. max. 42°C.



Rozmery (viď strana 17)



Servisné diely (viď strana 17)

XXX = Farebné označenie

000 = chróm
400 = biela/chróm



Obsluha (viď strana 22)



Čistenie

nájdete v priloženej brožúre.



Osvedčenie o skúške
(viď strana 24)

安全技巧

-  装配时为避免挤压和切割受伤，必须戴上手套。

安装提示

- 安装前必须检查产品是否受到运输损害。安装后将不认可运输损害或表面损伤。
- 管道和阀门必须根据通用标准进行安装、冲洗和检查。
- 请遵守当地国家现行的安装规定。

符号说明



请勿使用含有乙酸的硅胶！

max. 安全功能 (参见第页 20)
≈ 42 °C

恒温阀芯的安全功能可以预先设定所希望的最高出水温度，例如最高温度为42°C



大小 (参见第页 17)



备用零件 (参见第页 17)

XXX = 颜色代码

000 = 镀铬
400 = 白色/镀铬



操作 (参见第页 22)



清洗

附有小手册



检验标记 (参见第页 24)

Montáž
viď strana 18



安装
参见第页 18



Указания по технике безопасности

- Во время монтажа следует надеть перчатки во избежание прищемления и порезов.

Указания по монтажу

- Перед монтажом следует проверить изделие на предмет повреждений при перевозке. После монтажа претензии о возмещении ущерба за повреждения при перевозке или повреждения поверхностей не принимаются.
- Трубы и арматура должны быть установлены, промыты и проверены в соответствии с действующими нормами.
- Необходимо соблюдать требования по монтажу, действующие в соответствующих странах.

Описание символов



Не применяйте силикон, содержащий уксусную кислоту.

max. Safety Function (см. стр. 20)
≈ 42 °C

С помощью функции Safety Function может быть задана максимальная температура воды, например 42° C.



Размеры (см. стр. 17)



Комплект (см. стр. 17)

XXX = Цветная кодировка

000 = хром
400 = белый/хром



Эксплуатация (см. стр. 22)



Очистка

см прилагаемая брошюра



Знак технического контроля
(см. стр. 24)

Biztonsági utasítások

- A szerelésnél a zúzódások és vágási sérülések elkerülése érdekében kesztyűt kell viselni.

Szerelési utasítások

- A szerelés előtt ellenőrizni kell, hogy a terméknek nincs-e szállítási sérülése. Beépítés után a szállítási vagy felületi sérüléseket nem ismerik el.
- A vezetékeket és a csaptelepet az érvényes szabványoknak megfelelően kell felszerelni, öblíteni és ellenőrizni
- Az egyes országokban érvényes installációs irányelveket be kell tartani.

Szimbólumok leírása



Ne használjon ecetsavtartalmú szilikont!

max. Safety Function (Biztonsági funkció) (lásd a oldalon 20)
≈ 42 °C

A biztonsági funkciónak köszönhetően a kívánt hőmérsékletet pl. 42 Celsius fokban maximalizálhatjuk.



Méretet (lásd a oldalon 17)



Tartozékok (lásd a oldalon 17)

XXX = Szinkódolás

000 = króm
400 = fehér/króm



Használat (lásd a oldalon 22)



Tisztítás

lásd a mellékelt brosrútát.



Vizsgajel (lásd a oldalon 24)





Turvallisuusohjeet

- Asennuksessa on käytettävä käsiineitä puristumien ja viiltojen aiheuttamien tapaturmien estämiseksi.

Asennusohjeet

- Ennen asennusta on tarkastettava tuotteen mahdolliset kuljetusvahingot. Asennuksen jälkeen kuljetus- ja pintavaurioita ei hyväksytä.
- Putket ja hana on asennettava, huuhdeltava ja tarkastettava voimassa olevien standardien mukaisesti.
- Jokaisessa maassa on noudatettava siellä päteviä asennusohjeita.

Merkin kuvaus



Älä käytä etikahappopitoista silikonia!

max. Safety Function (katso sivu 20) ≈ 42 °C

Safety Function:ista johtuen haluttu maksimilämpötila voidaan esiasettaa, esimerkiksi maks. 42° C.



Mitat (katso sivu 17)



Varaosat (katso sivu 17)

XXX = Värikooodaus

000 = kromi

400 = valkoinen/kromi



Käyttö (katso sivu 22)



Puhdistus

katso oheinen esite



Koestusmerkki (katso sivu 24)

Säkerhetsanvisningar

- Handskar ska bäras under monteringsarbetet så att man kan undvika kläm- och skärskadorgen werden.

Monteringsanvisningar

- Det måste undersökas om produkten har transportskador innan den monteras. Efter monteringen accepteras inga transport- eller ytskiktsskador.
- Ledningarna och blandaren måste monteras, spolas igenom och kontrolleras enligt de gällande normerna.
- De installationsriktlinjer som gäller i länderna ska följas.

Symbolförklaring



Använd inte silikon som innehåller ättiksyra!

max. Safety Function (se sidan 20) ≈ 42 °C

Med hjälp av Safety Function kan du ställa in den önskade maximaltemperaturen till exempelvis 42°C och så förhindra skällningsrisk för barn.



Måtten (se sidan 17)



Reservdelar (se sidan 17)

XXX = Färgkodning

000 = krom

400 = vit/krom



Hantering (se sidan 22)



Rengöring

se den medföljande broschyren



Testsigill (se sidan 24)





Saugumo technikos nurodymai

- ⚠ Apsaugai nuo užspaudimo ir įsijovimo montavimo metu mūvėkite pirštines.

Montavimo instrukcija

- Prieš montuojant būtina patikrinti, ar gaminy nebuvu pažeistas transportavimo metu. Sumontavus pretenzijos dėl transportavimo ir paviršiaus pažeidimų nepriimamos.
- Vamzdžiai ir sujungimai turi būti montuojami, plaunami ir tikrinami pagal galiojančias normas.
- Laikykitės atitinkamoje šalyje galiojančių direktyvų dėl įrengimo.

Simbolio aprašymas



Nenaudokite silikono, kurio sudėtyje yra acto rūgšties!

max. Apsaugos funkcija (žr. psl. 20)
≈ 42° C

"Safety" funkcija karšto vandens temperatūra gali būti iš anksto ribota iki, pvz., ne aukštesnės kaip 42° C.



Išmatavimai (žr. psl. 17)



Atsarginės dalys (žr. psl. 17)

XXX = Spalvos

000 = chrom
400 = balta/chrom



Eksploatacija (žr. psl. 22)



Valymas

žr. pridedamoje brošiūroje.



Bandymo pažyma (žr. psl. 24)

Sigurnosne upute

- ⚠ Prilikom montaže se radi sprječavanja prignječenja i posjekotina moraju nositi rukavice.

Upute za montažu

- Prije montaže mora se provjeriti je li proizvod oštećen prilikom transporta. Nakon ugradnje se ne priznaju nikakve reklamacije koje se odnose na površinska i transportna oštećenja.
- Cijevi i armatura moraju biti postavljeni, isprani i testirani prema važećim normama.
- Obvezno se moraju uvažiti propisi o instalacijama koji vrijede u dotičnoj zemlji.

Opis simbola



Nemojte koristiti silikon koji sadrži octenu kiselinu!

max. Safety funkcija
≈ 42° C (pogledaj stranicu 20)

Zahvaljujuću Safety funkciji može se podesiti željena maksimalna temperatura, npr. i 42° C



Mjere (pogledaj stranicu 17)



Rezervni djelovi
(pogledaj stranicu 17)

XXX = Boje

000 = krom
400 = bijela/krom



Upotreba (pogledaj stranicu 22)



Čišćenje

se u priloženoj brošiuri.



Oznaka testiranja
(pogledaj stranicu 24)

Montavimas
žr. psl. 18



Sastavljanje
pogledaj stranicu 18



⚠ Güvenlik uyarıları

- ⚠ Montaj esnasında ezilme ve kesilme gibi yaralanmaları önlemek için eldiven kullanılmalıdır.

Montaj açıklamaları

- Montaj işleminden önce ürün nakliye hasarları yönünden kontrol edilmelidir. Montaj işleminden sonra nakliye veya yüzey hasarları için sorumluluk üstlenilmemektedir.
- Boruların ve armatürün montajı, yıkanması ve kontrolü geçerli normlara göre yapılmalıdır.
- Ülkelerde geçerli kurulum yönetmeliklerine riayet edilmelidir.

Simge açıklaması



Asetik asit içeren silikon kullanmayın!

max. Safety Function (bakınız sayfa 20)
≈ 42 °C

Emniyet fonksiyonu sayesinde, istenen maksimum sıcaklık Örn; maks. 42° C önceden ayarlanabilir.



Ölçüleri (bakınız sayfa 17)



Yedek Parçalar (bakınız sayfa 17)

XXX = Renkler

000 = krom
400 = beyaz/Krom



Kullanımı (bakınız sayfa 22)



Temizleme

birlikte verilen broşür



Kontrol işareti (bakınız sayfa 24)

⚠ Instrucțiuni de siguranță

- ⚠ La montare utilizați mănuși pentru evitarea contuziunilor și tăierii mâinilor.

Instrucțiuni de montare

- Înainte de instalare verificați, dacă produsul prezintă deteriorări de transport. După instalare garanția nu acoperă deteriorările de transport și cele de suprafață.
- Conductele și bateriile trebuie montate, spălate și verificate conform normelor în vigoare.
- Respectați reglementările referitoare la instalare valabile în țara respectivă.

Descrierea simbolurilor



Nu utilizați silicon cu conținut de acid acetic!

max. Funcția de siguranță (vezi pag. 20)
≈ 42 °C

Datorită funcției de siguranță puteți prereglea temperatura maximă, de ex. 42° C.



Dimensiuni (vezi pag. 17)



Piese de schimb (vezi pag. 17)

XXX = Coduri de culori

000 = crom
400 = alb/crom



Utilizare (vezi pag. 22)



Curățare

vezi broșura alăturată.



Certificat de testare
(vezi pag. 24)

Montajı
bakınız sayfa 18



Montare
vezi pag. 18

**⚠ Υποδειξεις ασφαλείας**

- ⚠ Για να αποφύγετε τραυματισμούς κατά τη συναρμολόγηση πρέπει να φοράτε γάντια.

Οδηγίες συναρμολόγησης

- Πριν τη συναρμολόγηση πρέπει να εξεταστεί το προϊόν για ζημιές μεταφοράς. Μετά την εγκατάσταση δεν αναγνωρίζονται ζημιές από τη μεταφορά ή επιφανειακές ζημιές.
- Οι σωλήνες και η μπαταρία πρέπει να τοποθετηθούν σύμφωνα με τα ισχύοντα πρότυπα, να τεθούν υπό πίεση και να δοκιμαστούν.
- Θα πρέπει να τηρούνται οι οδηγίες εγκατάστασης που ισχύουν σε κάθε κράτος.

Περιγραφή συμβόλων

Μην χρησιμοποιείτε σιλικόνη που περιέχει οξικό οξύ!

max. Safety Function (Λειτουργία ασφαλείας) (βλ. Σελίδα 20)

Χάρη στη λειτουργία ασφαλείας Safety Function, είναι δυνατή η προρρύθμιση της επιθυμητής μέγιστης θερμοκρασίας (π.χ. 42° C).

Διαστάσεις (βλ. Σελίδα 17)



Ανταλλακτικά (βλ. Σελίδα 17)



XXX = Χρώματα

000 = Επιχρωμωμένο

400 = λευκό/Επιχρωμωμένο

Χειρισμός (βλ. Σελίδα 22)



Καθαρισμός

βλ. συνημμένο φυλλάδιο



Σήμα ελέγχου (βλ. Σελίδα 24)

**⚠ Varnostna opozorila**

- ⚠ Pri montaži je treba nositi rokavice, da se preprečijo poškodbe zaradi zmečkanja ali urezov.

Navodila za montažo

- Pred montažo je treba izdelek preveriti glede morebitnih transportnih poškodb. Po vgradnji transportne ali površinske poškodbe ne bodo več priznane.
- Cevi in armaturo je treba montirati, izprati in preveriti po veljavnih standardih.
- Upravljanje je treba pravilnike o inštalacijah, ki veljajo v posamezni državi.

Opis simbola

Ne smete uporabiti silikona, ki vsebuje očetno kislino!

max. Varnostna funkcija . (glejte stran ≈ 42° C 20)

Varnostna funkcija omogoča, da vnaprej nastavimo najvišjo želeno temperaturo npr. 42° C.

Mere (glejte stran 17)



Rezervni deli (glejte stran 17)



XXX = Barve

000 = krom

400 = bela/krom

Upravljanje (glejte stran 22)



Čiščenje

glejte priloženi brošuri.



Preskusni znak (glejte stran 24)



Συναρμολόγηση
βλ. Σελίδα 18



Montaža
glejte stran 18



Ohutusjuhised

- △ Kandke paigaldamisel muljumis- ja löikevigastuste vältimiseks kindaid.

Paigaldamisjuhised

- Enne paigaldamist tuleb toodet kontrollida transportdikahjustuste osas Pärast paigaldamist ei tunnustata enam transporti- või pinnakahjustuste kaebuseid.
- Voolikute ja segisti paigaldamisel, loputamisel ja kontrollimisel tuleb lähtuda kehtivatest normatiividest
- Vastavas riigis kehtivaid paigalduseeskirju tuleb järgida.

Sümbolite kirjeldus



Ärge kasutage äädikhapet sisaldavat silikooni!

max. Turvafunktsioon (vt lk 20)

≈ 42 °C

Tänu ohutusfunktsioonile on võimalik soovitud maksimaaltemperatuuri eelnevalt sisestada (nt maks. 42 °C).



Mõõtude (vt lk 17)



Varuosad (vt lk 17)

XXX = Värvid

000 = kroom

400 = valge/kroom



Kasutamine (vt lk 22)



Puhastamine

vt kaasasolevast brošüürist.



Kontrollsertifikaat (vt lk 24)

Drošības norādes

- △ Montāžas laikā, lai izvairītos no saspiedumiem un iegriezumiem, nepieciešams nēsāt cimdus.

Norādījumi montāžai

- Pirms montāžas nepieciešams pārbaudīt, vai produktam transportēšanas laikā nav radušies bojājumi. Pēc iebūvēšanas bojājumi, kas radušies transportēšanas laikā, vai virsmas bojājumi netiek atzīti.
- Cauruļvadi un armatūra ir jāuzstāda, jāizskalo un jāpārbauda saskaņā ar spēkā esošajiem standartiem.
- Jāievēro attiecīgās valstīs spēkā esošās montāžas prasības.

Simbolu nozīme



Neizmantojiet silikonu, kas satur etiķskābi!

max. Drošības funkcija (skat. lpp. 20)

≈ 42 °C

Pateicoties drošības funkcijai, vēlamo augstāko temperatūru, piem., maks. 42 °C, var iestatīt jau iepriekš.



Izmērus (skat. lpp. 17)



Rezerves daļas (skat. lpp. 17)

XXX = Krāsu kodi

000 = hroma

400 = balta/hroma



Lietošana (skat. lpp. 22)



Tīrīšana

skatiet pievienotajā brošūrā.



Pārbaudes zīme (skat. lpp. 24)

Paigaldamine
vt lk 18



Montāža
skat. lpp. 18



Sigurnosne napomene

- ⚠ Prilikom montaže se radi sprečavanja prignječenja i posekotina moraju nositi rukavice.

Instrukcije za montažu

- Pre montaže se mora proveriti da li je proizvod oštećen pri transportu. Nakon ugradnje se ne priznaju nikakve reklamacije koje se odnose na površinska i transportna oštećenja.
- Vodovi i armatura moraju biti postavljeni, isprani i testirani prema važećim normama.
- Treba se pridržavati propisa koji u određenim zemljama važe za instalacije.

Opis simbola



Nemojte koristiti silikon koji sadrži sirćetnu kiselinu!

max. Safety funkcija (vidi stranu 20)
≈ 42 °C

Zahvaljujuću Safety funkciji, može se podesiti željena maksimalna temperatura, npr. maks. 42 °C.



Mere (vidi stranu 17)



Rezervni delovi (vidi stranu 17)

XXX = Oznake boja

000 = hrom
400 = bela/hrom



Rukovanje (vidi stranu 22)



Čišćenje

vidi priloženoj brošuri.



Ispitni znak (vidi stranu 24)

Sikkerheshenvisninger

- ⚠ Bruk hanser under montasjen for å unngå klem- og kuttskader.

Montagehenvisninger

- Før montasjen skal produktet sjekkes for transportskader. Etter monteringen aksepteres ikke noen transport- eller overflateskader.
- Ledningene og armaturen skal monteres, spyles og sjekkes iht. de gyldige normer.
- Gjeldende retningslinjer for rørleggerarbeid i de enkelte land skal følges.

Symbolbeskrivelse



Ikke bruk silikon som inneholder eddiksyre!

max. Safety Function (se side 20)
≈ 42 °C

Takket være egenskapen "Safety Function" kan det forhåndsinnstilles en ønsket maks. temperatur, f.eks. 42 °C.



Mål (se side 17)



Servicelever (se side 17)

XXX = Fargekode

000 = krom
400 = hvit/krom



Betjening (se side 22)



Rengjøring

se vedlagt brosjyre.



Prøvermerke (se side 24)





Указания за безопасност

- При монтажа трябва да се носят ръкавици, за да се избегнат наранявания поради притискане или порязване.

Указания за монтаж

- Преди монтажа продуктът трябва да се провери за транспортни щети. След монтажа не се признават транспортни или повърхностни щети.
- Тръбопроводите и арматурата трябва да се монтират, промият и проверят в съответствие с валидните норми.
- Трябва да бъдат спазвани валидните в съответните страни предписания за инсталиране.

Описание на символите



Не използвайте силикон, съдържащ оцетна киселина!

max. Safety Function (Функция за безопасност) (вижте стр. 20)

Благодарение на Safety Function (функция за безопасност) желаната максимална температура може да се настрои предварително напр. на макс. 42 °C.

Размери (вижте стр. 17)



Сервизни части (вижте стр. 17)

XXX = Цветово кодиране

000 = хром
400 = бял/хром



Обслужване (вижте стр. 22)



Почистване

от приложената брошура.



Контролен знак (вижте стр. 24)

Udhëzime sigurie

- Për të evituar lëndimet e pickimeve ose të prerjeve gjatë procesit të montimit duhet që të vishni doreza.

Udhëzime për montimin

- Përpara montimit duhet që produkti të kontrollohet për dëmtime nga transporti. Pas instalimit nuk do të njihet asnjë dëmtim nga transporti ose dëmtim i sipërfaqes.
- Tubacionet dhe rubinetet duhet që të montohen, të shpëlahen dhe të kontrollohen sipas standardeve në fuqi
- Duhet të respektohen linjat udhëzuese të instalimit, të vlefshme për vendet respektive.

Përshkrimi i simbolit



Mos përdorni silikon që në përbërje ka acid acetik.

max. Funksonet e sigurisë (shih faqen ≈ 42 °C 20)

Falë Safety Function mund të përcaktohet temperatura maksimale e dëshiruar, p.sh. 42 °C.

Përmasat (shih faqen 17)



Pjesët e servisit (shih faqen 17)

XXX = Kodimi me anë të ngjyrave

000 = krom
400 = e bardhë/krom



Përdorimi (shih faqen 22)



Pastrimi

shikoni broshurën bashkëngjitur.



Shenja e kontrollit (shih faqen 24)





⚠️ تنبيهات الأمان

⚠️ يجب إرتداء قفازات لليد أثناء التركيب لتجنب حدوث أخطار الإنحشار أو الجروح.

تعليمات التركيب

- قبل القيام بعملية التركيب، يجب فحص المنتج للتأكد من خلوه من أية تلفيات ناتجة عن النقل. بعد القيام بعملية التركيب، لن يتم الاعتراف بوجود أية تلفيات سطحية أو تلفيات ناتجة عن عملية النقل.
- يجب تركيب وغسيل واختبار التوصيلات وخلطات المياه طبقاً للمعايير السارية.
- يجب مراعاة القواعد الخاصة بالتركيب وأعمال السباكة وفقاً للوائح الخاصة بكل بلد.

وصف الرمز

هام! لا تستخدم السليكون الذي يحتوي على أحماض!



max. 42°C
≈

يمكن إجراء ضبط مسبق للحد الأقصى لدرجة الحرارة المرغوبة، على سبيل المثال بحد أقصى 42° بفضل وظيفة الأمان.

أبعاد (راجع صفحة 17)



قطع الغيار (راجع صفحة 17)



XXX = الألوان

000 = كروم

400 = أبيض/كروم

التشغيل (راجع صفحة 22)



التنظيف

راجع والكتيب المرفق



شهادة اختبار (راجع صفحة 24)



التركيب

راجع صفحة 18

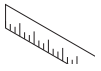

PuraVida

15474000 / 15474400

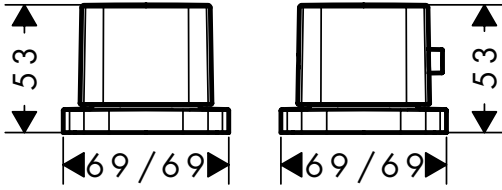

PuraVida

15474000 / 15474400

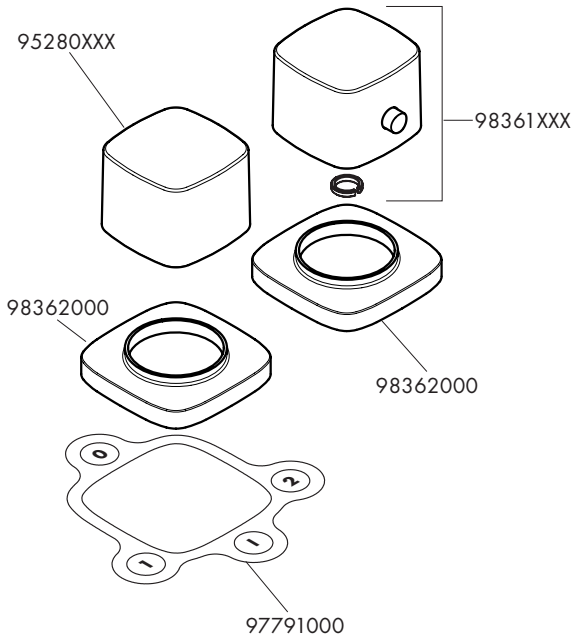

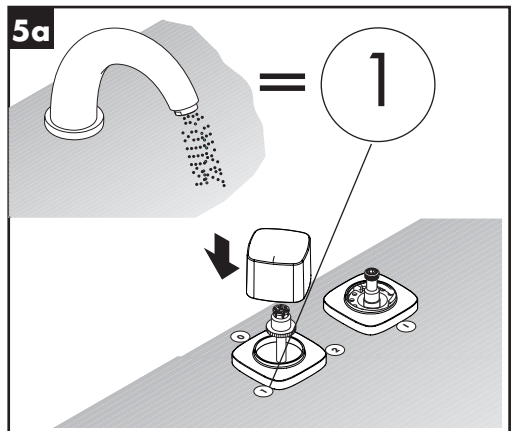
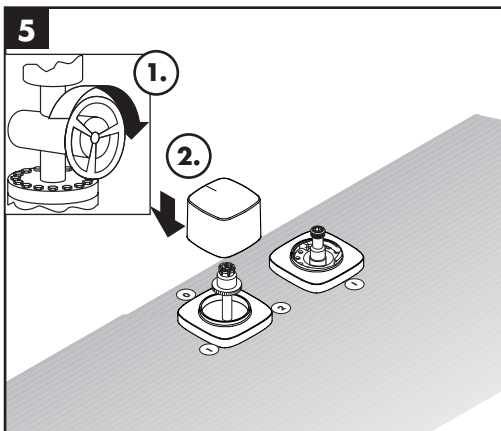
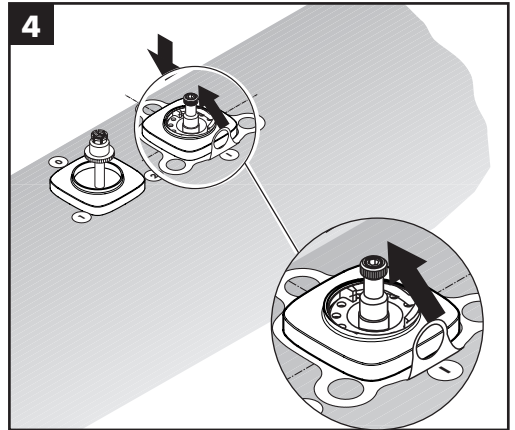
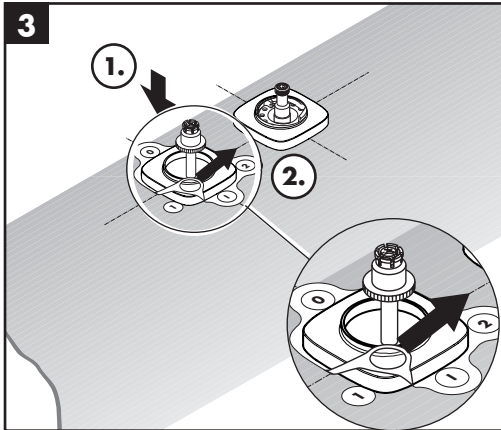
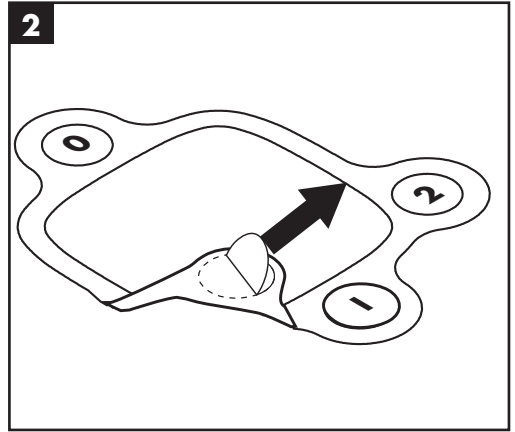
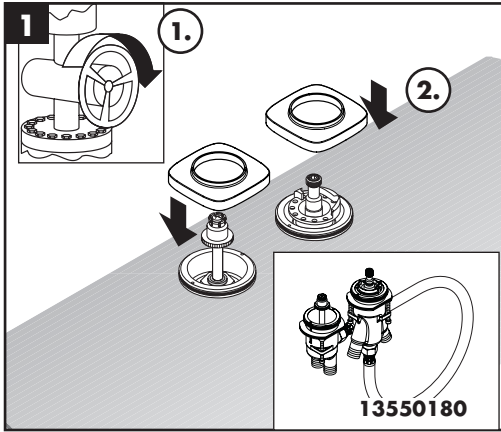

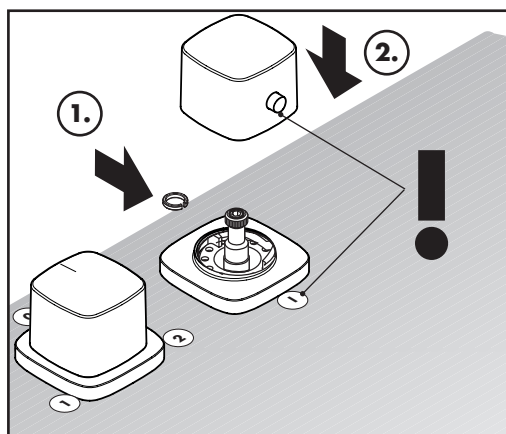
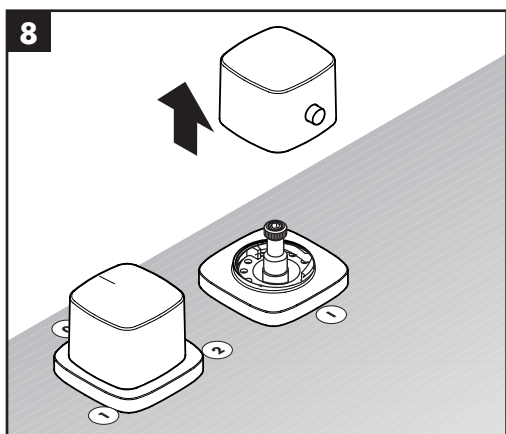
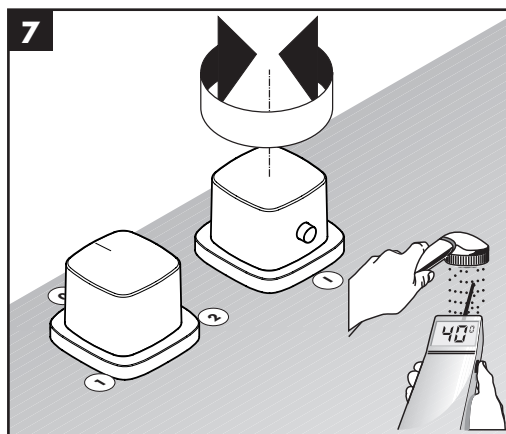
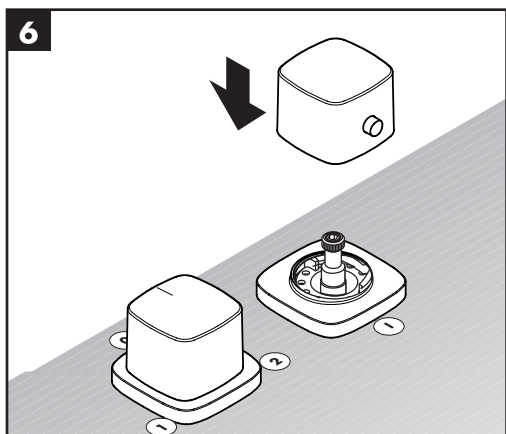
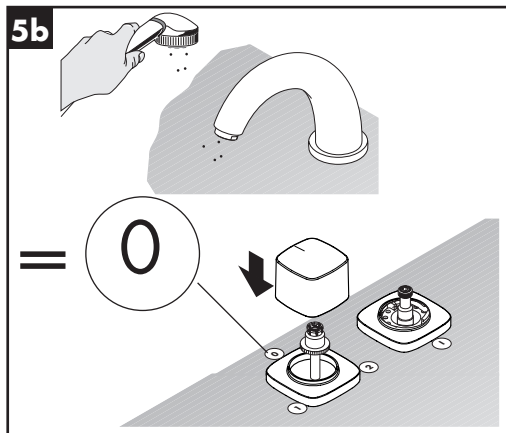
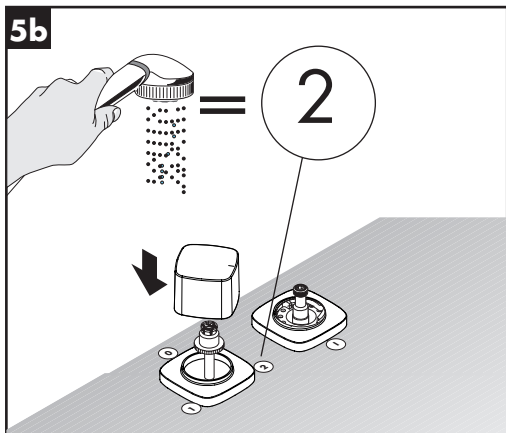

max.
≈ 42 °C

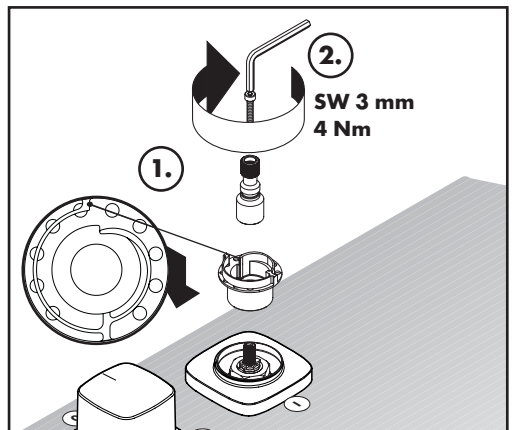
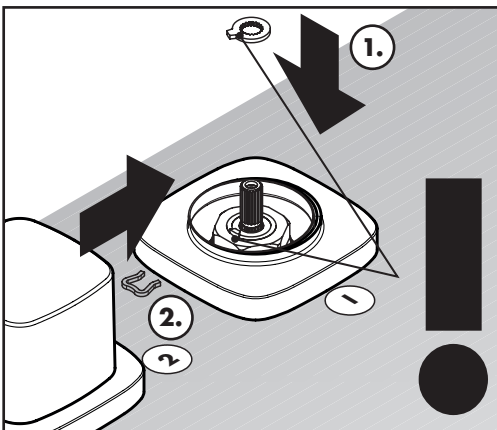
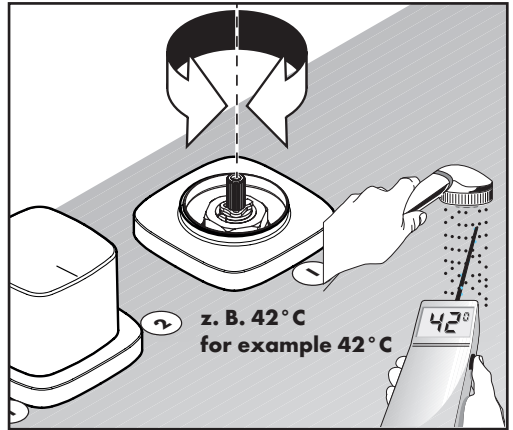
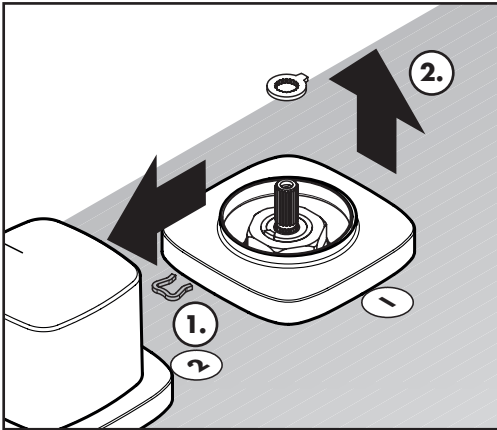
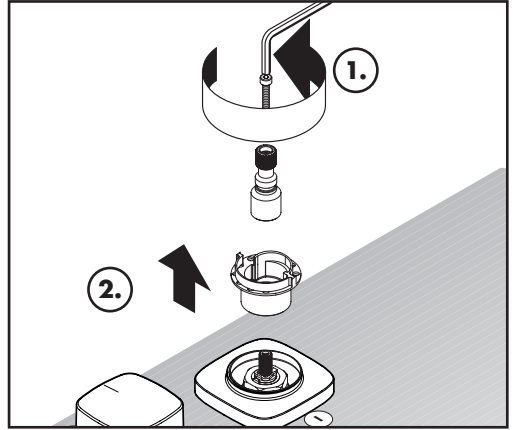
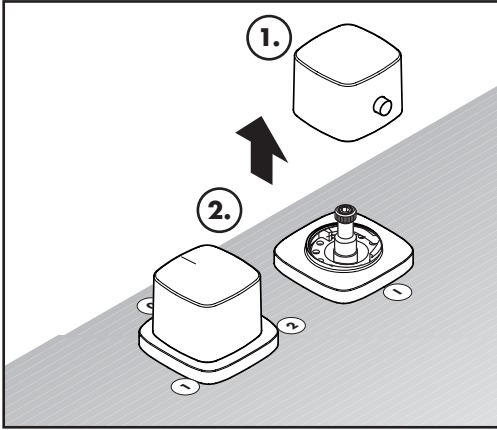

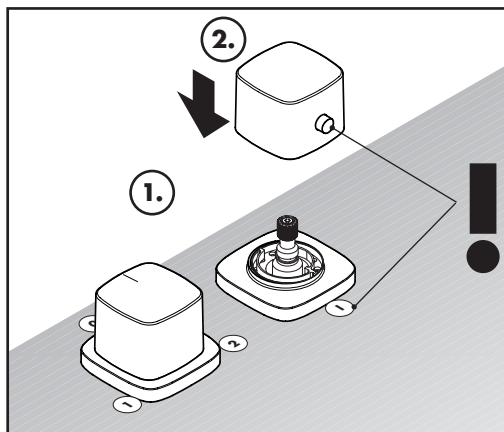

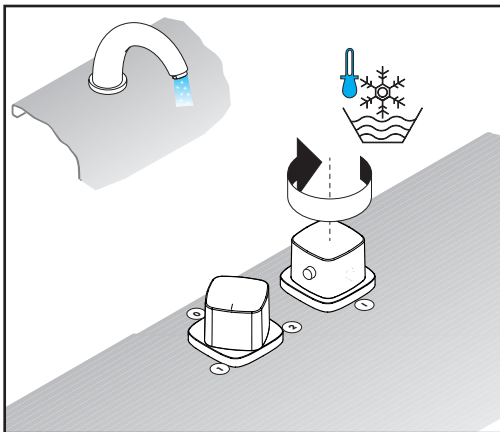
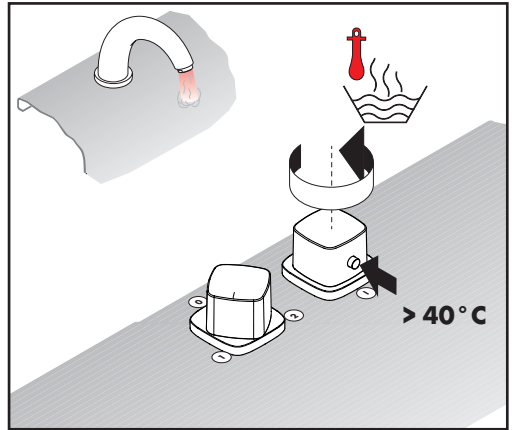
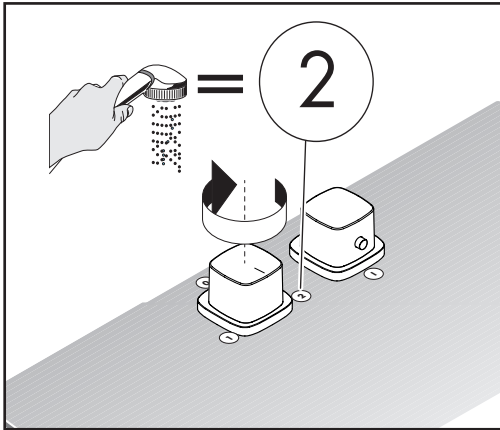
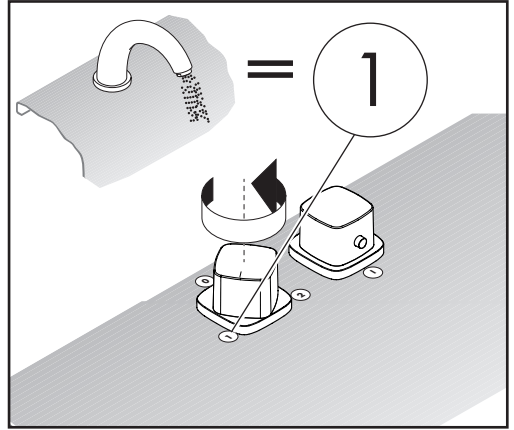
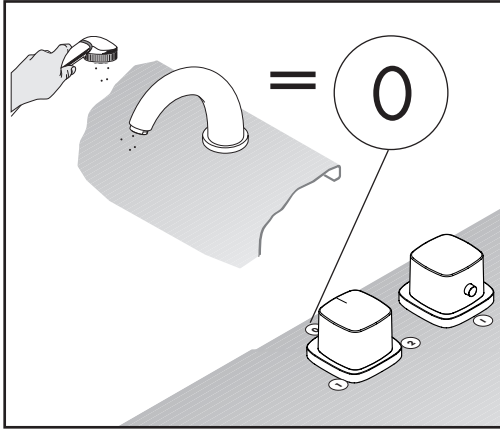



P-IX

DVGW

SVGW

ACS

WRAS

KIWA

ETA

15474XXX P-IX 9653/ICC

