

DE	Gebrauchsanleitung / Montageanleitung	2
FR	Mode d'emploi / Instructions de montage	3
EN	Instructions for use / assembly instructions	4

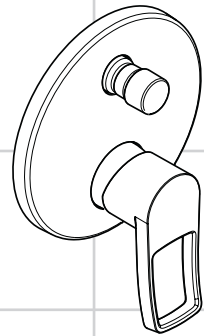

Sanibel
14404000
14406000

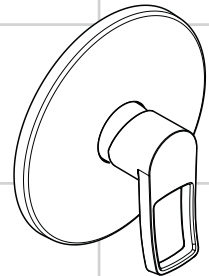

Sanibel
14604000



Ihr Online-Fachhändler für:

hansgrohe

- Kostenlose und individuelle Beratung
- Hochwertige Produkte
- Kostenloser und schneller Versand

- TOP Bewertungen
- Exzelerter Kundenservice
- Über 20 Jahre Erfahrung



E-Mail: info@unidomo.de | Tel.: 04621 - 30 60 89 0 | www.unidomo.de



Sicherheitshinweise

- ⚠ Bei der Montage müssen zur Vermeidung von Quetsch- und Schnittverletzungen Handschuhe getragen werden.
- ⚠ Das Produkt darf nur zu Bade-, Hygiene- und Körperreinigungszwecken eingesetzt werden.
- ⚠ Große Druckunterschiede zwischen den Kalt- und Warmwasseranschlüssen müssen ausgeglichen werden.

Montagehinweise

- Vor der Montage muss das Produkt auf Transportschäden untersucht werden. Nach dem Einbau werden keine Transport- oder Oberflächenschäden anerkannt.
- Die Leitungen und die Armatur müssen nach den gültigen Normen montiert, gespült und geprüft werden.
- Die in den Ländern jeweils gültigen Installationsrichtlinien sind einzuhalten.

Technische Daten

Betriebsdruck:	max. 1 MPa
Empfohlener Betriebsdruck:	0,1 - 0,5 MPa
Prüfdruck:	1,6 MPa
(1 MPa = 10 bar = 147 PSI)	
Heißwassertemperatur:	max. 70 °C
Empfohlene Heißwassertemperatur:	65 °C
Thermische Desinfektion:	max. 70 °C / 4 min

14406000: Eigensicher gegen Rückfließen

Das Produkt ist ausschließlich für Trinkwasser konzipiert!

Symbolerklärung



Kein essigsäurehaltiges Silikon verwenden!



Justierung (siehe Seite 8)

Einstellen der Warmwasserbegrenzung. In Verbindung mit Durchlauferhitzern ist eine Warmwassersperre nicht zu empfehlen.



Maße (siehe Seite 9)



Durchflussdiagramm

(siehe Seite 9)

freier Durchfluss

- ① Abgang Brause
- ② Abgang Wanne



Bedienung (siehe Seite 5)



Wartung (siehe Seite 10)

14406000: Die Sicherheitseinrichtungen müssen gemäß DIN EN 1717 regelmäßig in Übereinstimmung mit nationalen oder regionalen Bestimmungen (einmal jährlich) auf ihre Funktion geprüft werden.



Reinigung

siehe beiliegende Broschüre



Serviceteile (siehe Seite 12)



Prüfzeichen (siehe Seite 16)



Störung	Ursache	Abhilfe
Armatur schwergängig	- Kartusche defekt, verkalkt	- Kartusche austauschen
Armatur tropft	- Kartusche defekt	- Kartusche austauschen
Zu niedrige Warmwassertemperatur	- Warmwasserbegrenzung falsch eingestellt - Kreuzfluss	- Warmwasserbegrenzung einstellen - Kartusche austauschen
Umsteller funktioniert nicht	- Ablagerungen - Zu geringer Wasserdruck - Umsteller defekt	- Umsteller reinigen / O-Ringe fetten - Wasserdruck erhöhen - Umsteller austauschen



Montage siehe Seite 6



Consignes de sécurité

-  Lors du montage, porter des gants de protection pour éviter toute blessure par écrasement ou coupure.
-  Le produit ne doit servir qu'à se laver et à assurer l'hygiène corporelle.
-  Il est conseillé d'équilibrer les pressions de l'eau chaude et froide.

Instructions pour le montage

- Avant son montage, s'assurer que le produit n'a subi aucun dommage pendant le transport. Après le montage, tout dommage de transport ou de surface ne pourra pas être reconnu.
- Les conduites et la robinetterie doivent être montés, rincés et contrôlés selon les normes en vigueur.
- Les directives d'installation en vigueur dans le pays concerné doivent être respectées.

Informations techniques

Pression de service autorisée:	max. 1 MPa
Pression de service conseillée:	0,1 - 0,5 MPa
Pression maximum de contrôle: (1 MPa = 10 bar = 147 PSI)	1,6 MPa
Température d'eau chaude:	max. 70 °C
Température recommandée:	65 °C
Désinfection thermique:	max. 70 °C / 4 min

14406000: Avec dispositif anti-retour

Le produit est exclusivement conçu pour de l'eau potable!

Description du symbole



Ne pas utiliser de silicone contenant de l'acide acétique!



Etalonnage (voir pages 8)

Réglage de la limitation d'eau chaude. En liaison avec les chauffe-eau, un blocage de l'eau chaude n'est pas recommandable.



Dimensions (voir pages 9)



Diagramme du débit

(voir pages 9)
débit libre

- ① Sortie douche
- ② Sortie baignoire



Instructions de service (voir pages 5)



Entretien (voir pages 10)

14406000: Les clapets anti-retour doivent être examinés régulièrement conformément à la norme EN 1717 ou conformément aux dispositions nationales ou régionales quant à leur fonction (au moins une fois par an).



Nettoyage

voir la brochure ci-jointe



Pièces détachées (voir pages 12)



Classification acoustique et

débit (voir pages 16)

Dysfonctionnement	Origine	Solution
Dureté de fonctionnement	- Cartouche défectueuse, entartrée	- Changer la cartouche
Le mitigeur goutte	- Cartouche défectueuse	- Changer la cartouche
Température d'eau chaude trop basse, pas d'eau froide	- Limiteur de température mal positionné	- Positionner le limiteur de température
	- Flux inversé	- Changer la cartouche
L'inverseur ne fonctionne pas	- Dépôts	- Nettoyer l'inverseur / graisser les joints toriques
	- Pression d'alimentation insuffisante	- Augmenter la pression d'alimentation
	- Inverseur défectueux	- Changer l'inverseur



Montage voir pages 6



Safety Notes

- ⚠ Gloves should be worn during installation to prevent crushing and cutting injuries.
- ⚠ The product may only be used for bathing, hygienic and body cleaning purposes.
- ⚠ The hot and cold supplies must be of equal pressures.

Installation Instructions

- Prior to installation, inspect the product for transport damages. After it has been installed, no transport or surface damage will be honoured.
- The pipes and the fixture must be installed, flushed and tested as per the applicable standards.
- The plumbing codes applicable in the respective countries must be observed.

Technical Data

Operating pressure:	max. 1 MPa
Recommended operating pressure:	0,1 - 0,5 MPa
Test pressure:	1,6 MPa
(1 MPa = 10 bar = 147 PSI)	
Hot water temperature:	max. 70°C
Recommended hot water temp.:	65°C
Thermal disinfection:	max. 70°C / 4 min

14406000: Safety against backflow

The product is exclusively designed for drinking water!

Symbol description



Do not use silicone containing acetic acid!



Adjustment (see page 8)

To adjust the hot water limiter. Using a hot water limiter in combination with a continuous flow water heater is not recommended.

Dimensions (see page 9)



Flow diagram

(see page 9)

free flow

- ① Shower outlet
- ② Tub outlet



Operation (see page 5)



Maintenance (see page 10)

14406000: The safety device must be checked regularly according to DIN EN 1717 in accordance with national or regional regulations (at least once a year).



Cleaning

see enclosed brochure



Spare parts (see page 12)



Test certificate (see page 16)

Fault	Cause	Remedy
Mixer stiff	- Cartridge defective, calcified	- Exchange cartridge
Mixer dripping	- Cartridge defective	- Exchange cartridge
Hot water temperature too low	- Hot water limiter incorrectly set	- Set hot water limiter
	- Crossflow	- Exchange cartridge
Diverter not operating	- Residue	- Clean converter / grease O-rings
	- Water pressure to low	- Increase water pressure
	- Diverter defective	- Exchange diverter



Assembly see page 6

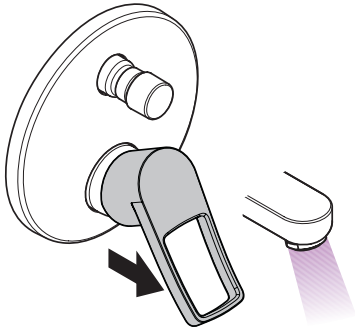

öffnen / ouvert / open

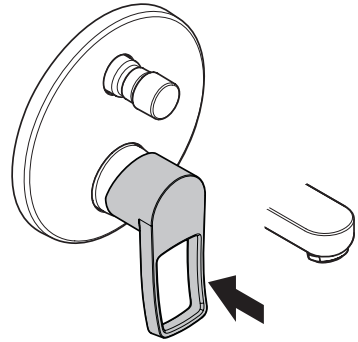

schließen / fermé / close

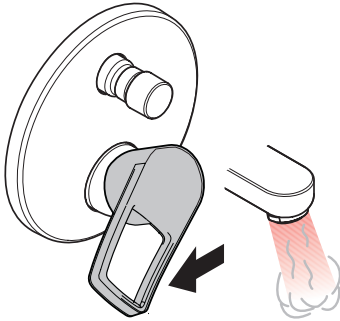

warm / chaud / hot



kalt / froid / cold

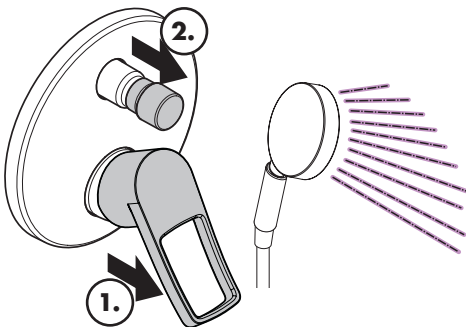

öffnen Brause / ouvert douche / open shower

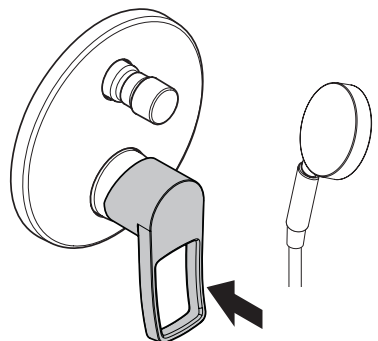

schließen Brause / fermé douche / close shower

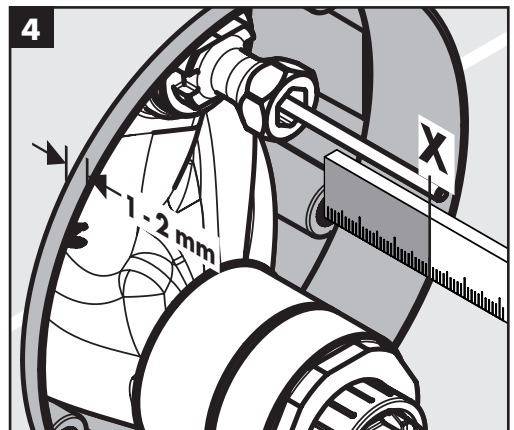
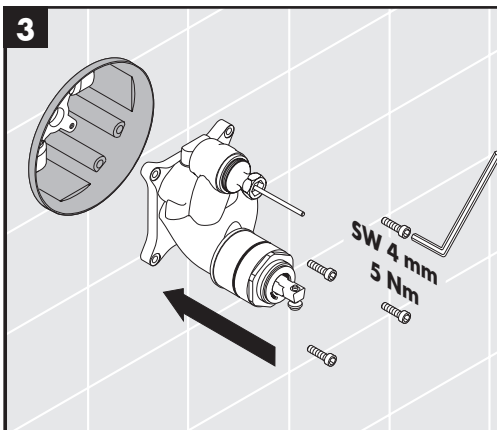
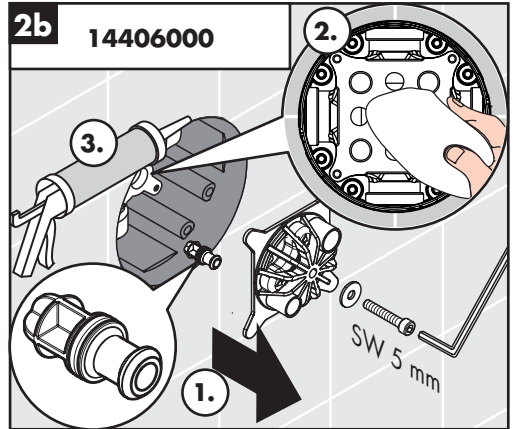
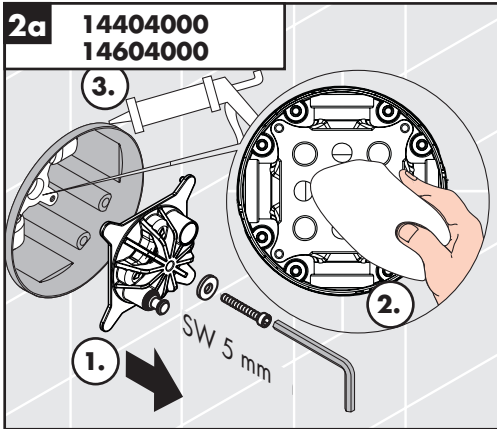
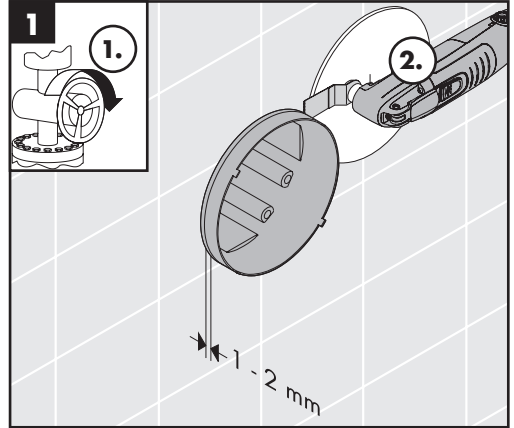
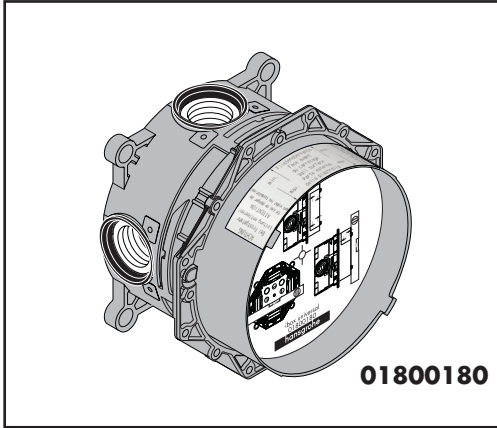

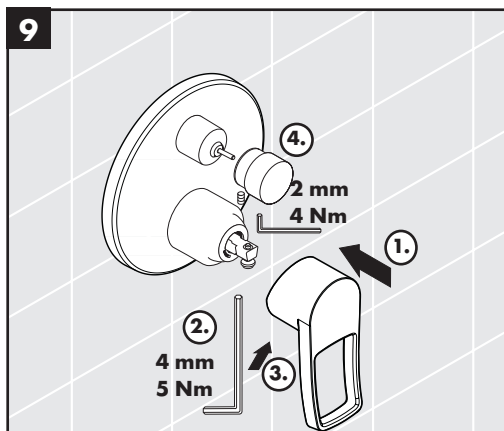
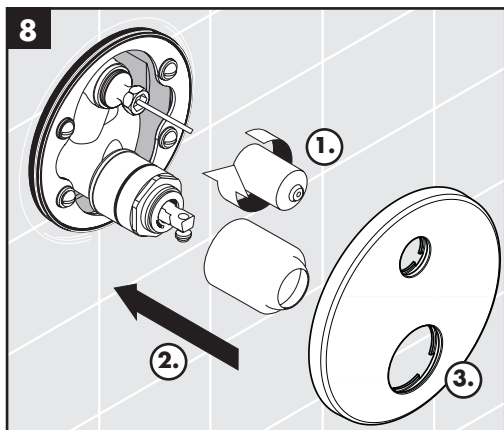
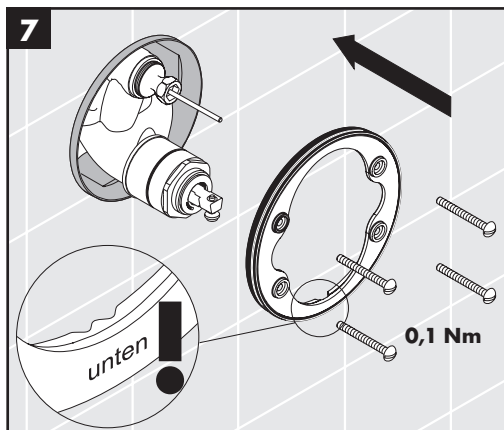
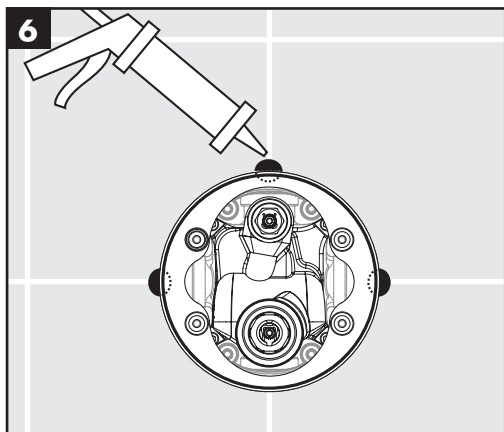
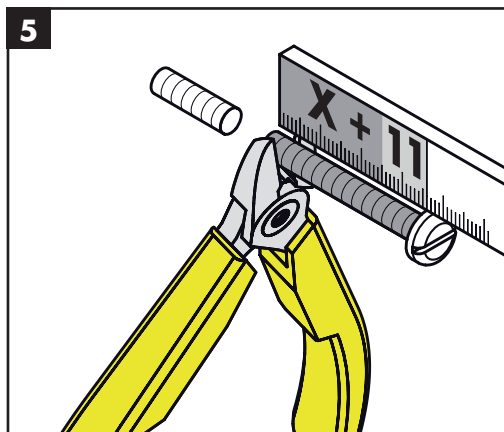

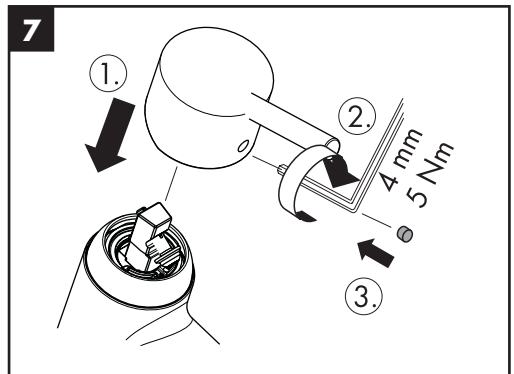
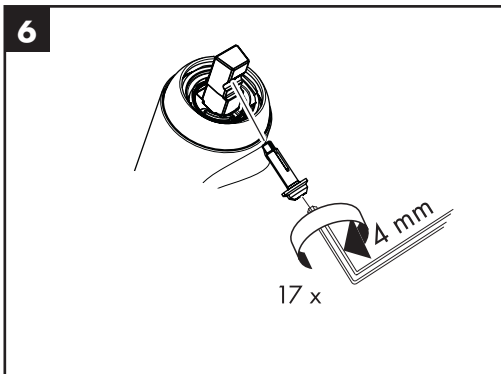
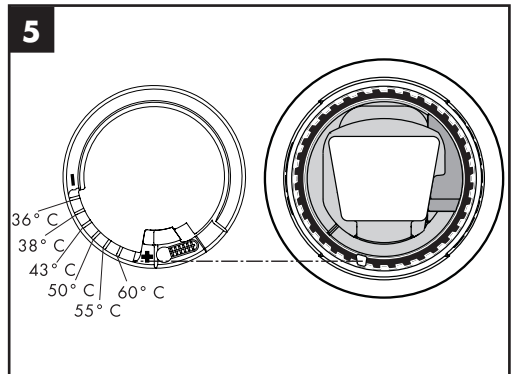
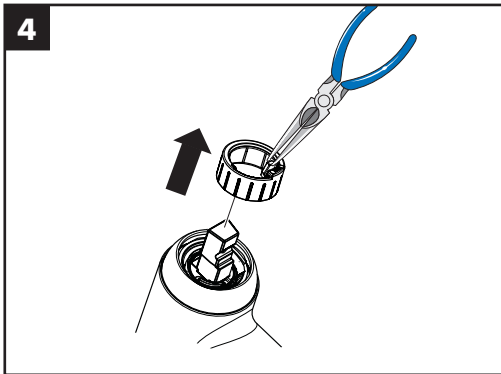
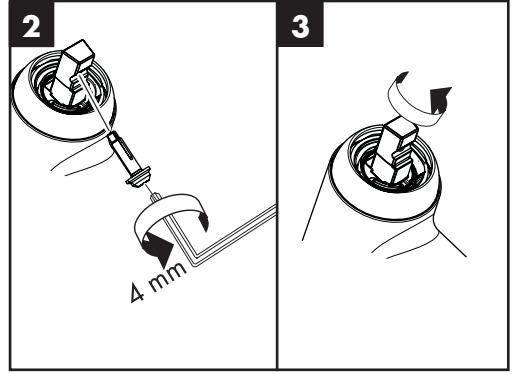
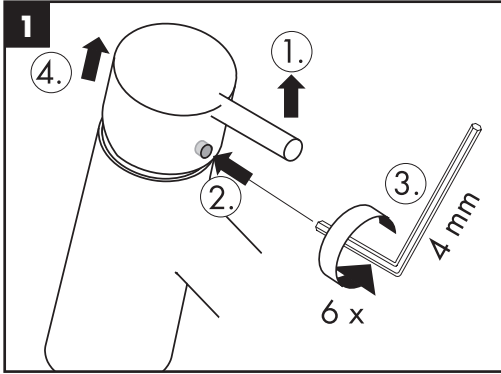
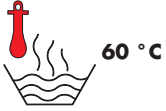

Sanibel 14404000 / 14406000

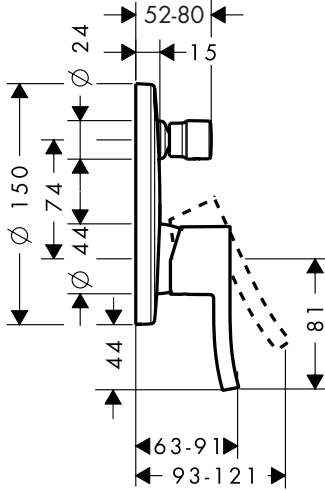

Sanibel 14604000

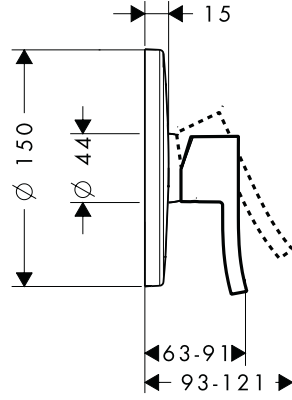

Sanibel 14404000

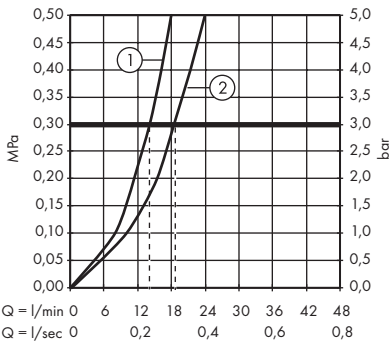

Sanibel 14604000

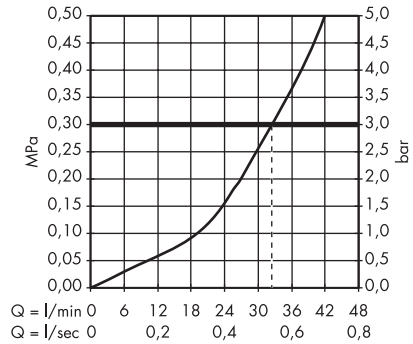

Sanibel 14406000

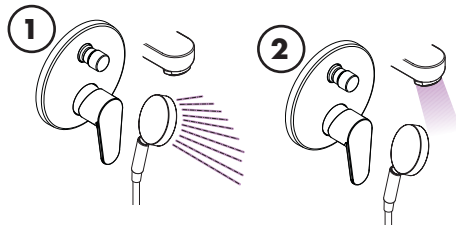
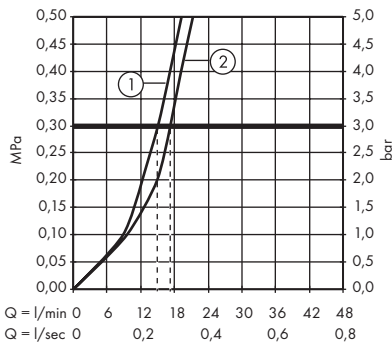

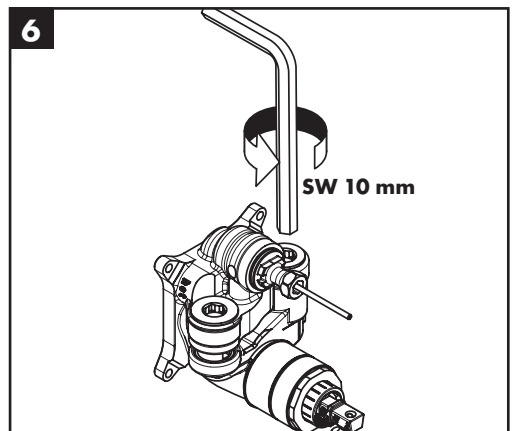
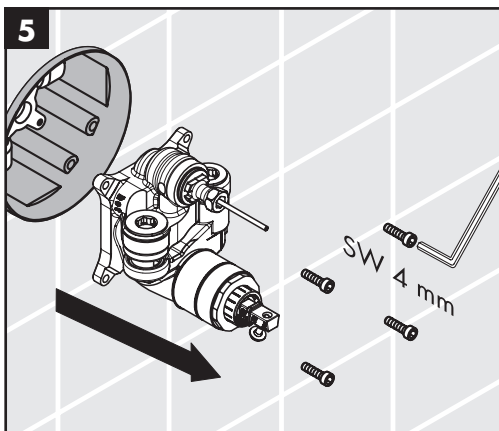
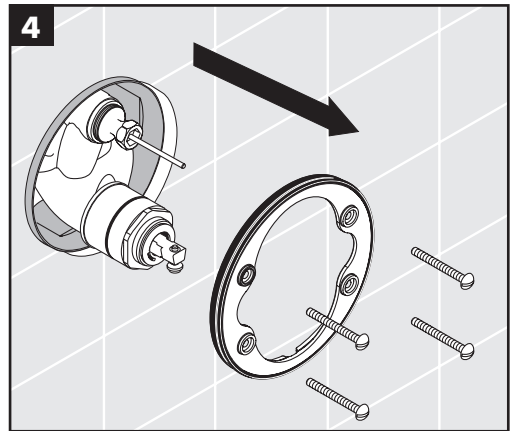
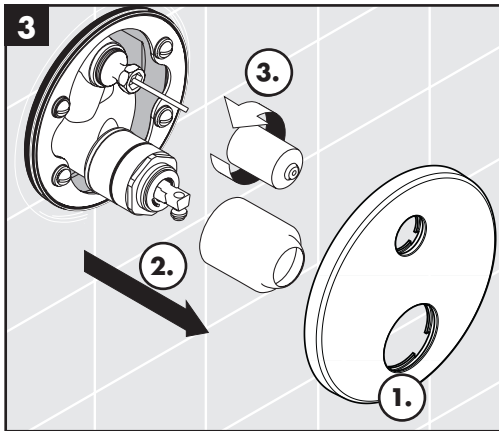
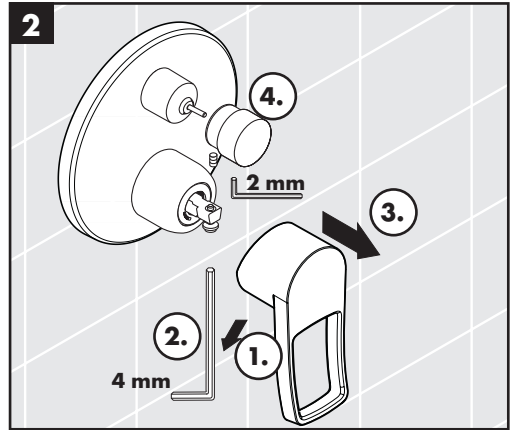
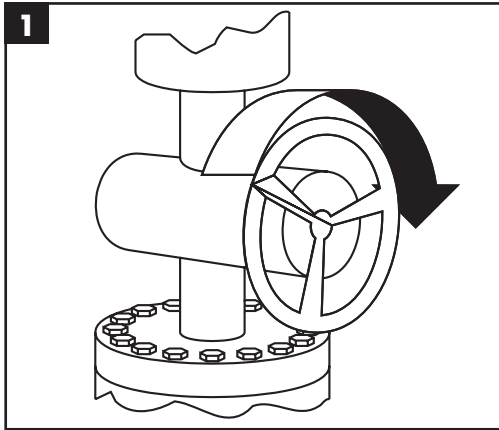

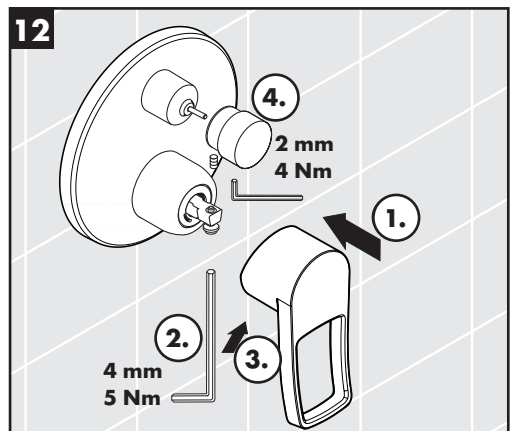
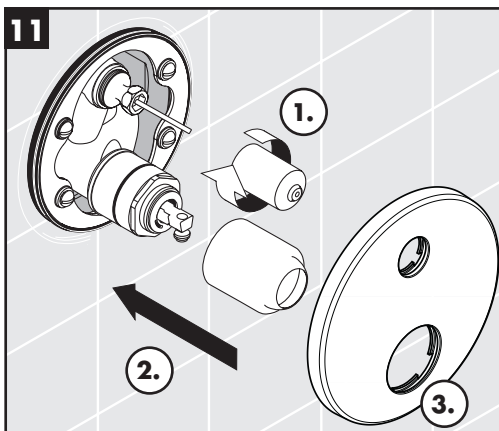
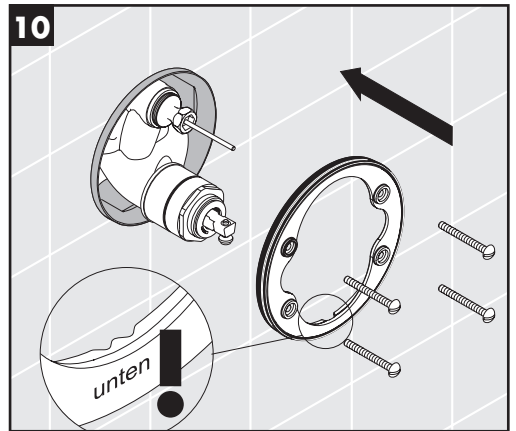
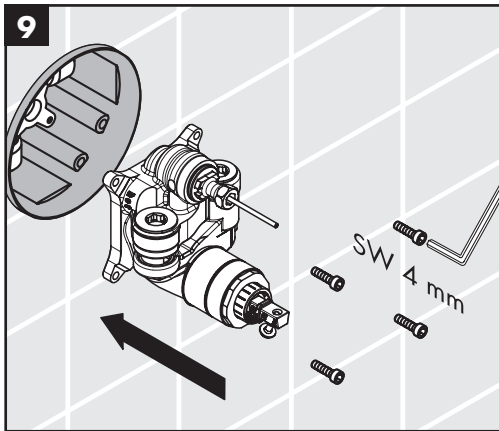
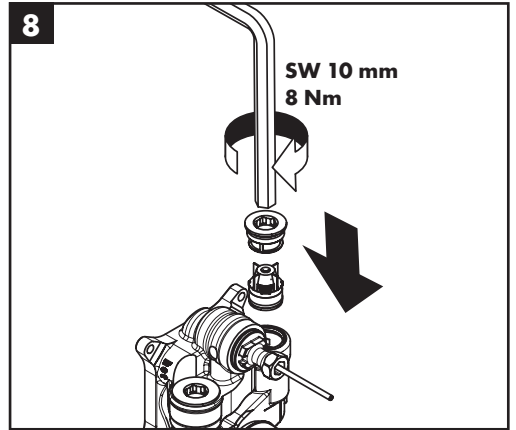
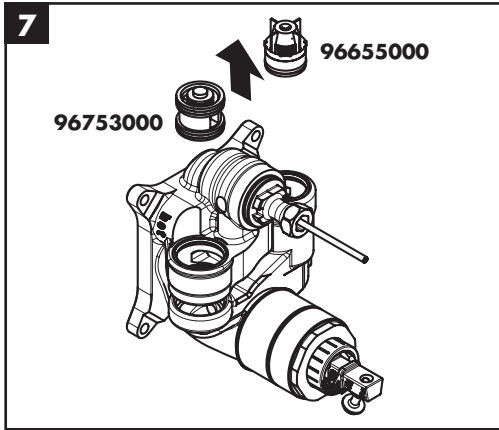



Sanibel

14404000 / 14406000

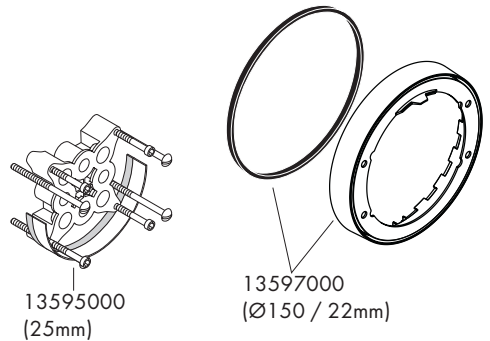
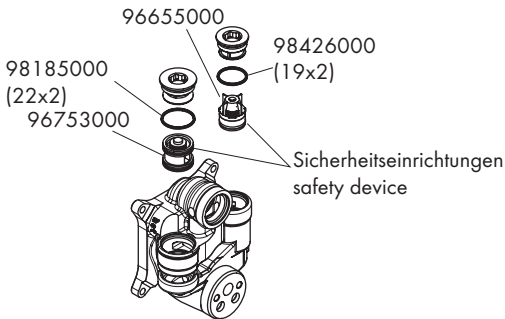
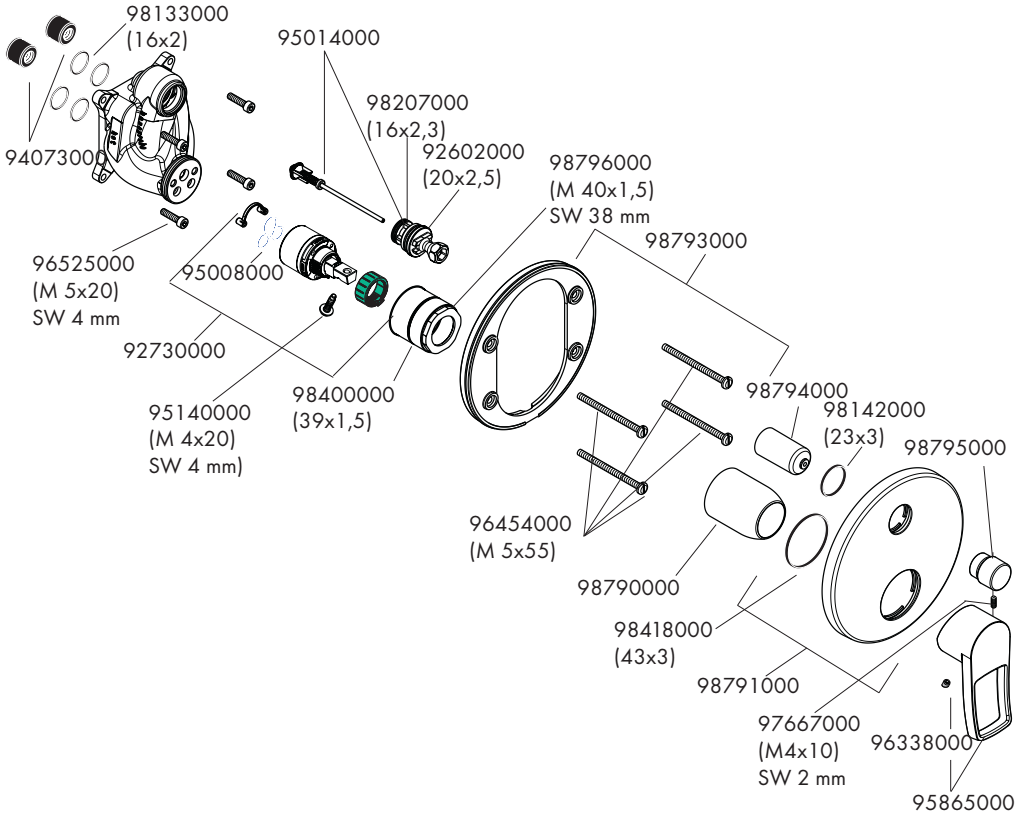



Sanibel
14604000

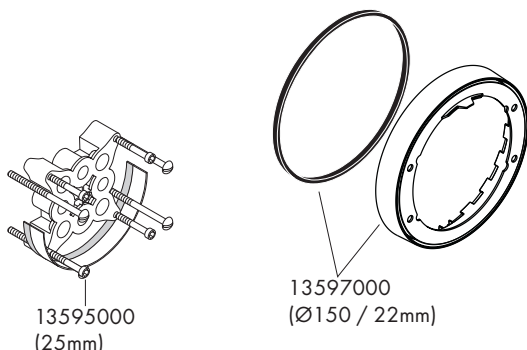
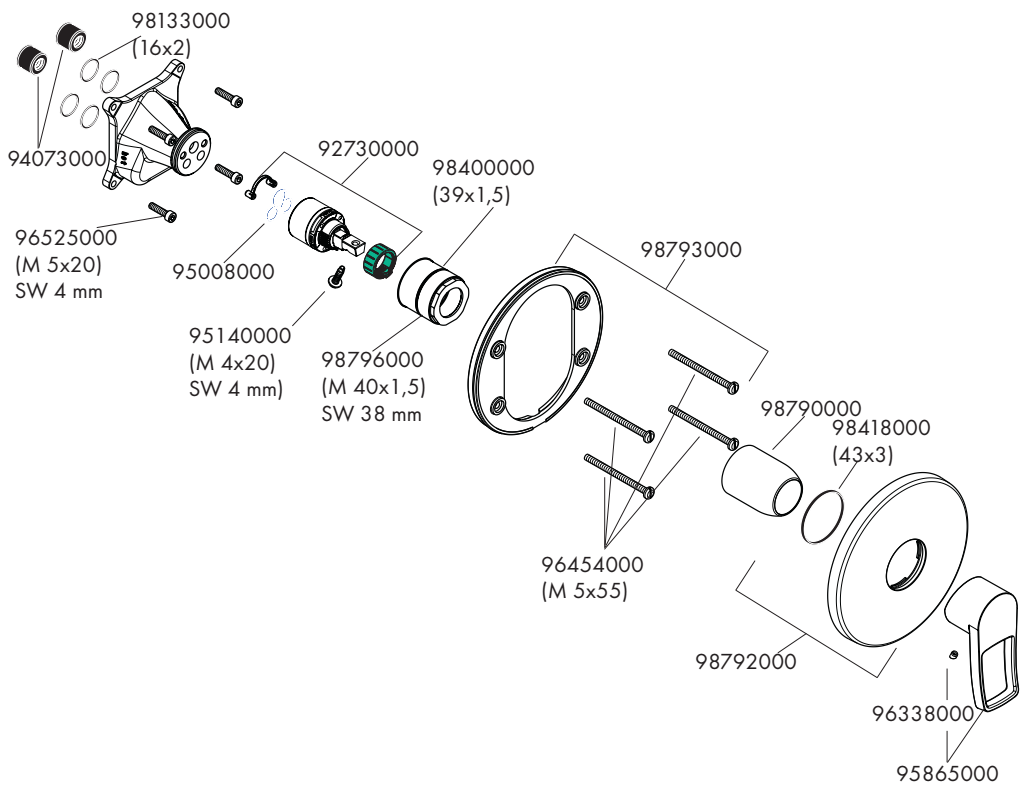







	P-IX	DVGW	SVGW	ACS	WRAS	ETA
14404000	PA-IX 9709/ICC		X	X	X	
14406000	PA-IX 18097/IDC					
14604000	PA-IX 9710/IB		X	X	X	

