

ZH 用户手册 / 组装说明	2
EN Instructions for use / assembly instructions	3
DE Gebrauchsanleitung / Montageanleitung	4

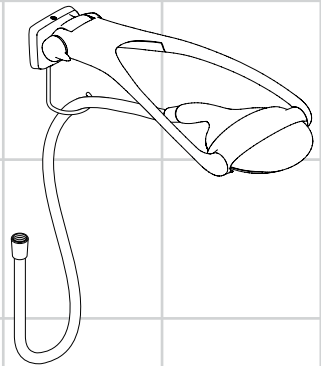

**Raindance
Allrounder Set**
28110007



Ihr Online-Fachhändler für:

hansgrohe

- Kostenlose und individuelle Beratung
- Hochwertige Produkte
- Kostenloser und schneller Versand

- TOP Bewertungen
- Exzelerter Kundenservice
- Über 20 Jahre Erfahrung



E-Mail: info@unidomo.de | Tel.: 04621 - 30 60 89 0 | www.unidomo.de



安全技巧

- △ 装配时为避免挤压和切割受伤，必须戴上手套。
- △ 不得让儿童和肢体、精神和/或意识有障碍的成人在不受监管的情况下使用淋浴系统。受酒精或毒品影响的人员不得使用淋浴系统。
- △ 淋浴系统只允许作为洗浴、卫生和洁身之用。
- △ 必须避免让身体敏感部位（如眼睛）接触到莲蓬头喷水。必须保持莲蓬头与人头之间有足够的距离。
- △ 该产品不得作扶柄使用。必须安装单独的扶柄。
- △ 淋浴软管只适合从淋浴器连接到管接头。切勿在管接头和软管之间安装截止装置。

安装提示

- 安装前必须检查产品是否受到运输损害。安装后将不认可运输损害或表面损伤。
- 管道和阀门必须根据通用标准进行安装、冲洗和检查。
- 请遵守当地国家现行的安装规定。
- 只有与汉斯格雅手提花洒和汉斯格雅淋浴器软管组合使用，方担保最佳的功能。
- 在安装产品的位置，安装人员必须确保安装面的墙面是平的（没有突出物或瓷砖没有突起），墙体结构适合产品的安装并没有弱点。包装内的膨胀螺丝只适用于混凝土墙体。对于其他墙体结构必须咨询膨胀螺丝生产商的建议。
- 必须装上花洒所附带的滤网密封垫，以过滤管道里的杂质污物。杂质污物会影响花洒的功能和/或损坏花洒的功能部件，由此而产生的产品损坏不属于汉斯格雅的保修范围。

技术参数

工作压强: 最大 0,6 MPa
 推荐工作压强: 0,1 - 0,4 MPa
 (1 MPa = 10 bar = 147 PSI)
 热水温度: 最大 60 °C
 热力消毒: 最大 70 °C / 4 分钟
 该产品专为饮用水设计！

符号说明



请勿使用含有乙酸的硅！



用偏心套管可以补偿消除钻孔的偏差。
(参见第页 6 / 8)



大小 (参见第页 10)



流量示意图
(参见第页 10)



操作 (参见第页 11)



清洗 (参见第页 13 并附有小手册)



备用零件 (参见第页 14)

选装附件 (不在供货范围内)

- #28105000 角安装测试 (参见第页 5)
- #28108000 转接器 (参见第页 7)



安装 参见第页 5



Safety Notes

- △ Gloves should be worn during installation to prevent crushing and cutting injuries.
- △ Children as well as adults with physical, mental and/or sensoric impairments must not use this shower system without proper supervision. Persons under the influence of alcohol or drugs are prohibited from using this shower system.
- △ The shower system may only be used for bathing, hygienic and body cleaning purposes.
- △ Do not allow the streams of the shower touch sensitive body parts (such as your eyes). An adequate distance must be kept between the shower and you.
- △ The product may not be used as a holding handle. A separate handle must be installed.
- △ Shower hoses are only suitable for a connection from the shower to the fitting. Never fit a shut-off device between the fitting and the hose.

Installation Instructions

- Prior to installation, inspect the product for transport damages. After it has been installed, no transport or surface damage will be honoured.
- The pipes and the fixture must be installed, flushed and tested as per the applicable standards.
- The plumbing codes applicable in the respective countries must be observed.
- Optimal functioning is only guaranteed with the combination of Hansgrohe hand showers and Hansgrohe shower hoses.
- Where the contractor mounts the product, he should ensure that the entire area of the wall to which the mounting plate is to be fitted, is flat (no projecting joints or tiles sticking out), that the structure of the wall is suitable for the installation of the product and has no weak points. The enclosed screws and dowels are only suitable for concrete. For another wall constructions the manufacturer's indications of the dowel manufacturer have to be taken into account.
- The mesh washer must be insert to protect the overhead shower against incoming dirt by pipework. Incoming dirt leads to defects or/and can damage parts of the shower; such caused faults voids all liability and guarantee claims.

Technical Data

Operating pressure: max. 0,6 MPa
 Recommended operating pressure: 0,1 – 0,4 MPa
 (1 MPa = 10 bar = 147 PSI)
 Hot water temperature: max. 60 °C
 Thermal disinfection: max. 70 °C / 4 min
 The product is exclusively designed for drinking water!

Symbol description



Do not use silicone containing acetic acid!



With the excentric washer it is possible to equalize tolerance of the drilling.
 (see page 6 / 8)



Dimensions (see page 10)



Flow diagram
 (see page 10)



Operation (see page 11)



Cleaning (see page 13 and enclosed brochure)



Spare parts (see page 14)

Special accessories (order as an extra)

- #28105000 corner fitting set
 (see page 5)
- #28108000 Adapter (see page 7)



Assembly see page 5



Sicherheitshinweise

- △ Bei der Montage müssen zur Vermeidung von Quetsch- und Schnittverletzungen Handschuhe getragen werden.
- △ Kinder, sowie Erwachsene mit körperlichen, geistigen und / oder sensorischen Einschränkungen dürfen das Duschsystem nicht unbeaufsichtigt benutzen. Personen, die unter Alkohol- oder Drogeneinfluss stehen, dürfen das Duschsystem nicht benutzen.
- △ Das Duschsystem darf nur zu Bade-, Hygiene- und Körperreinigungszwecken eingesetzt werden.
- △ Der Kontakt der Brausestrahlen mit empfindlichen Körperstellen (z. B. Augen) muss vermieden werden. Es muss ein ausreichender Abstand zwischen Brause und Körper eingehalten werden.
- △ Das Produkt darf nicht als Haltegriff benutzt werden. Es muss ein separater Haltegriff montiert werden.
- △ Brausenschläuche sind nur zum Anschluss von Brausen an Armaturen geeignet. Eine Absperrung nach dem Schlauch in Fließrichtung ist unzulässig!

Montagehinweise

- Vor der Montage muss das Produkt auf Transportschäden untersucht werden. Nach dem Einbau werden keine Transport- oder Oberflächenschäden anerkannt.
- Die Leitungen und die Armatur müssen nach den gültigen Normen montiert, gespült und geprüft werden.
- Die in den Ländern jeweils gültigen Installationsrichtlinien sind einzuhalten.
- Optimale Funktion nur in Verbindung mit Hansgrohe Handbrausen und Hansgrohe Brausenschläuchen garantiert.
- Bei der Montage des Produktes durch qualifiziertes Fachpersonal ist darauf zu achten, dass die Befestigungsfläche im gesamten Bereich der Befestigungsplan ist (keine vorstehenden Fugen oder Fliesenversatz), der Wandaufbau für eine Montage des Produktes geeignet ist und keine Schwachstellen aufweist. Die beigelegten Schrauben und Dübel sind nur für Beton geeignet. Bei anderen Wandaufbauten sind die Herstellerangaben des Dübelherstellers zu beachten.

- Die der Brause beigepackte Siebdichtung muss eingebaut werden, um Schmutzeinspülungen aus dem Leitungsnetz zu vermeiden. Schmutzeinspülungen können die Funktion beeinträchtigen und/oder zu Beschädigungen an Funktionsteilen der Brause führen, für hieraus ergebende Schäden haftet Hansgrohe nicht.

Technische Daten

Betriebsdruck:	max. 0,6 MPa
Empfohlener Betriebsdruck:	0,1 – 0,4 MPa
(1 MPa = 10 bar = 147 PSI)	
Heißwassertemperatur:	max. 60 °C
Thermische Desinfektion:	max. 70 °C / 4 min
Das Produkt ist ausschließlich für Trinkwasser konzipiert!	

Symbolerklärung



Kein essigsäurehaltiges Silikon verwenden!



Durch die Exzenterbuchse können Bohrtoleranzen ausgeglichen werden. (siehe Seite 6 / 8)



Maße (siehe Seite 10)



Durchflussdiagramm
(siehe Seite 10)



Bedienung (siehe Seite 11)



Reinigung (siehe Seite 13 und beiliegende Broschüre)



Serviceteile (siehe Seite 14)

Sonderzubehör (nicht im Lieferumfang enthalten)

- #28105000 Eckmontageset (siehe Seite 5)
- #28108000 Adapter (siehe Seite 7)



Montage siehe Seite 5

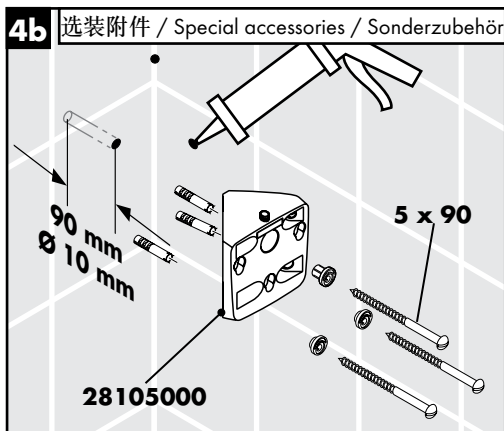
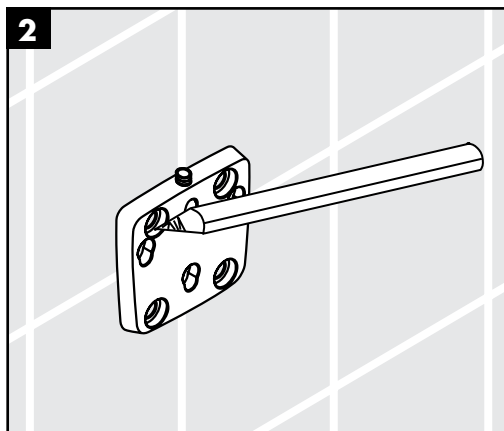
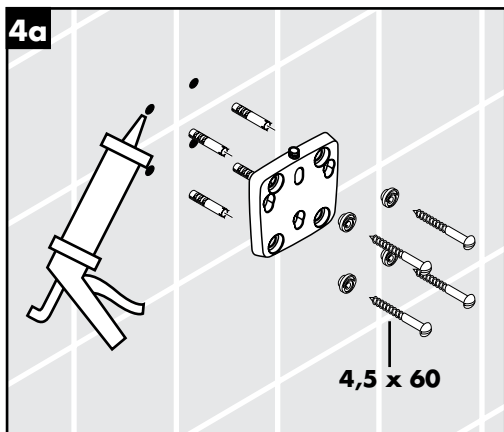
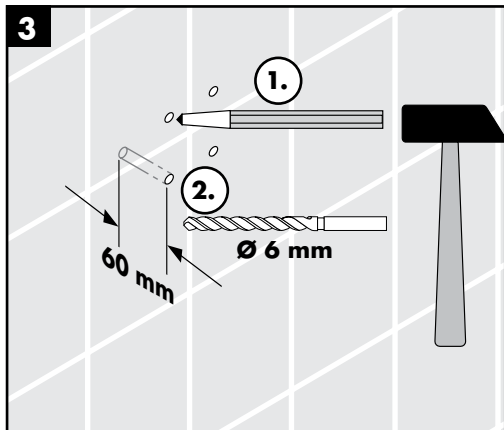
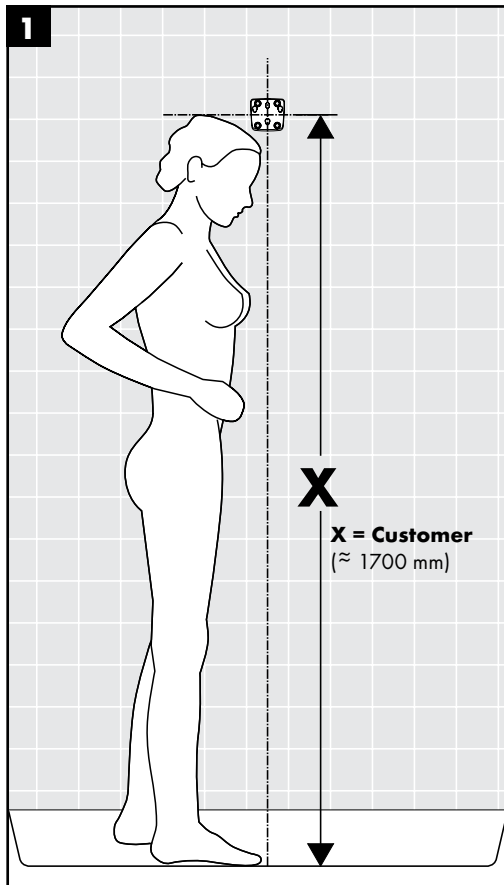

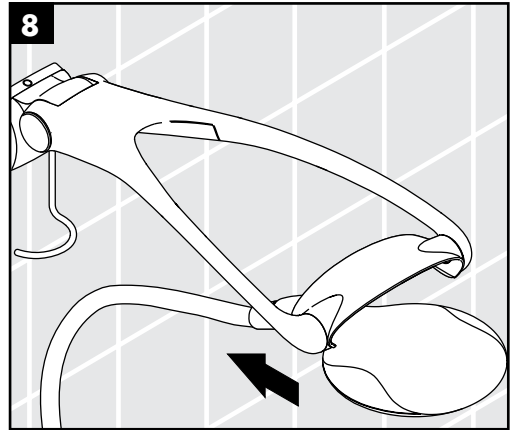
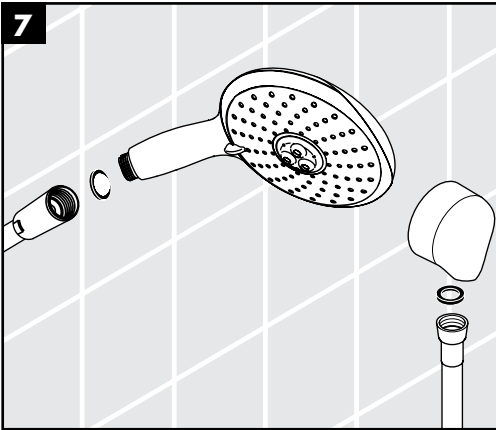
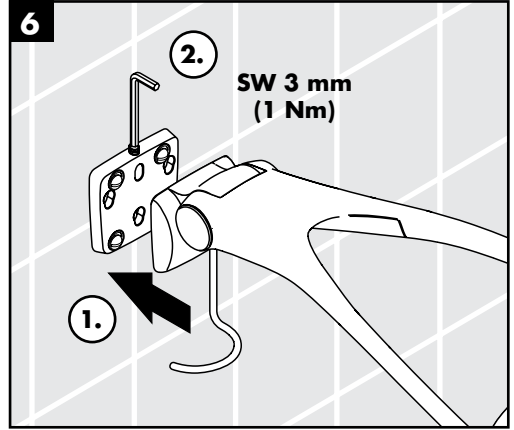
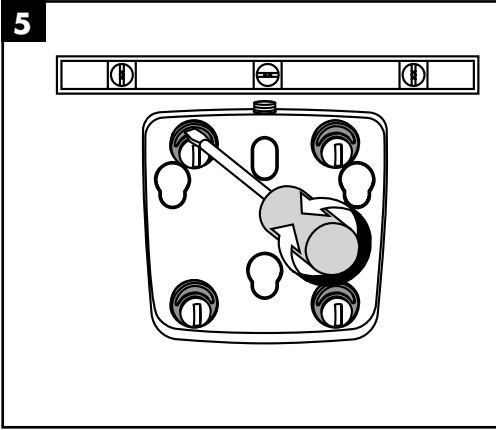



选装附件 / Special accessories / Sonderzubehör

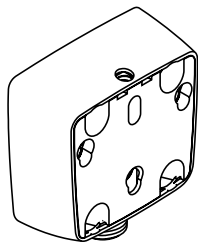

28108000

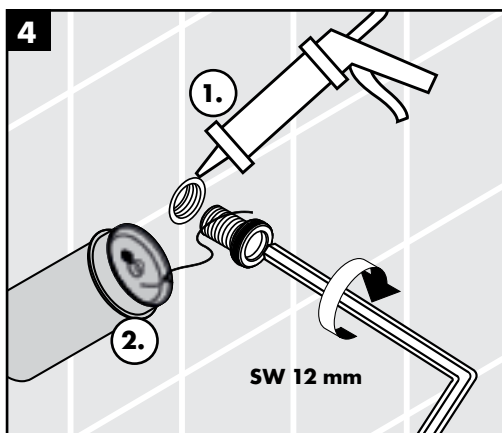
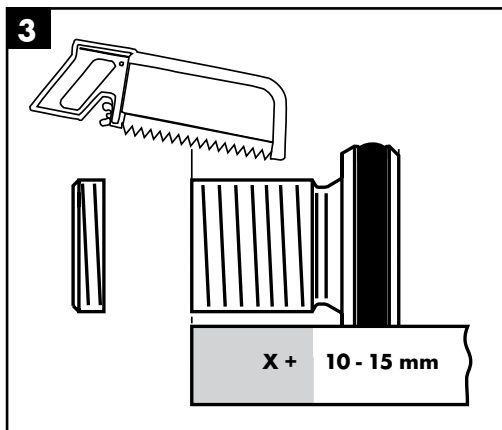
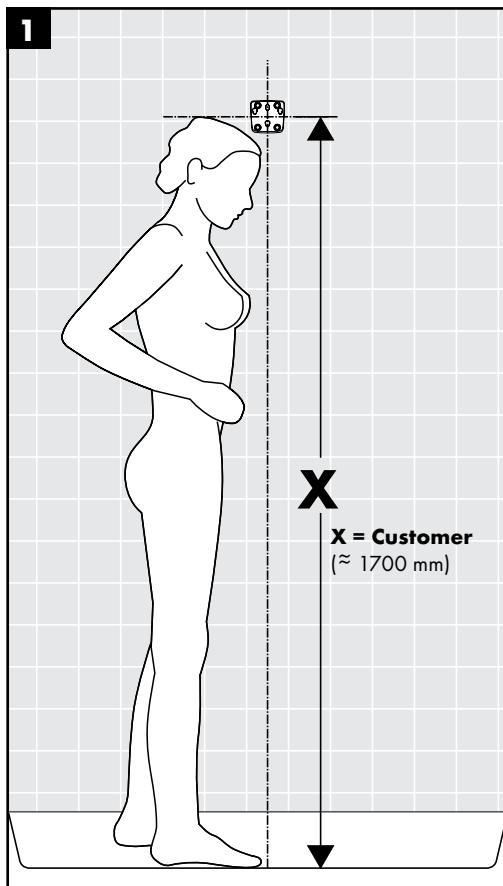
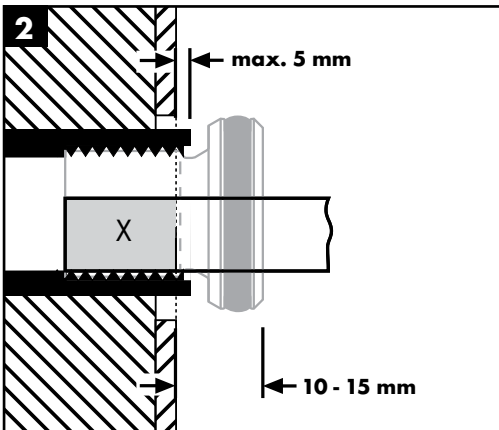

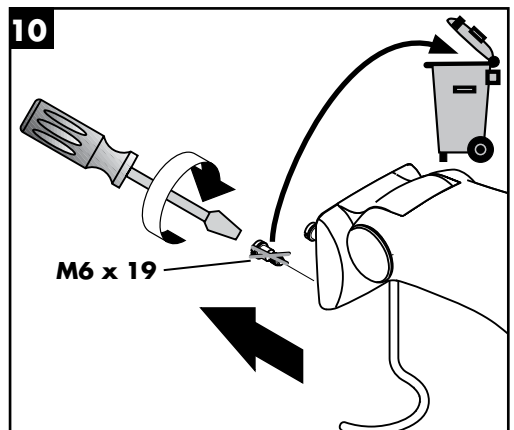
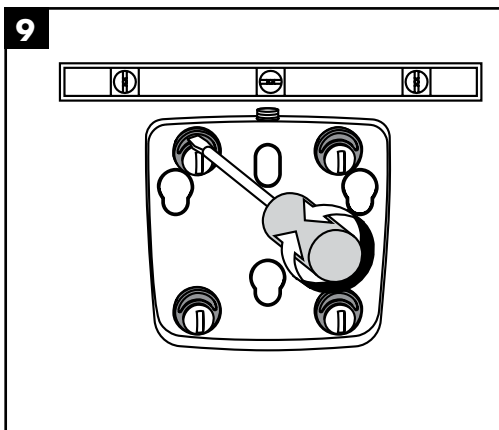
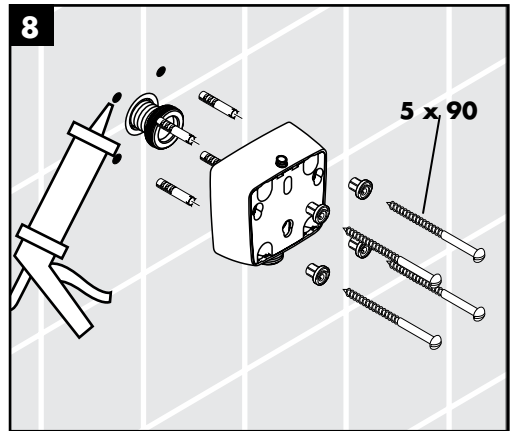
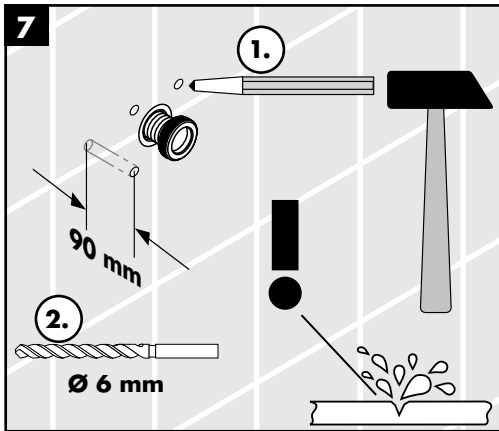
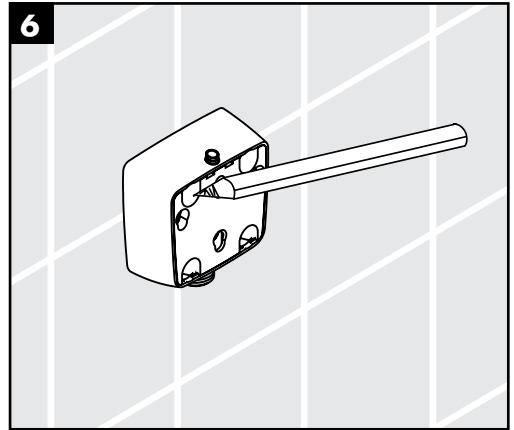
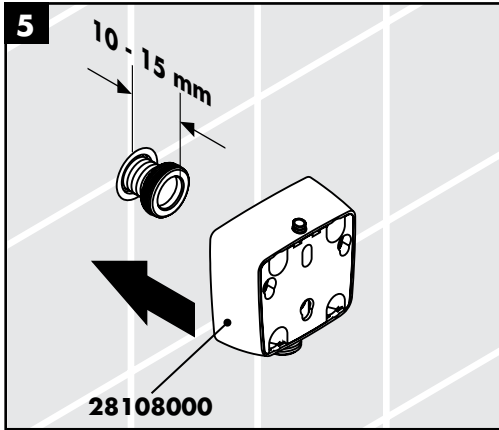

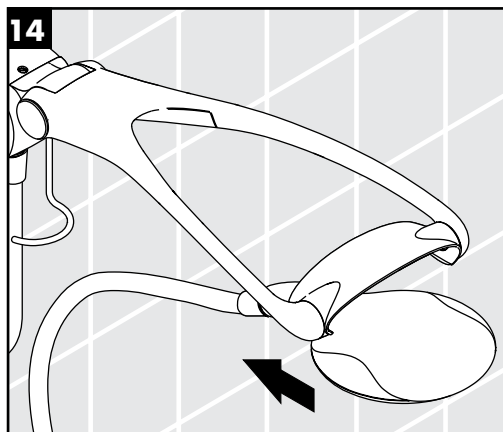
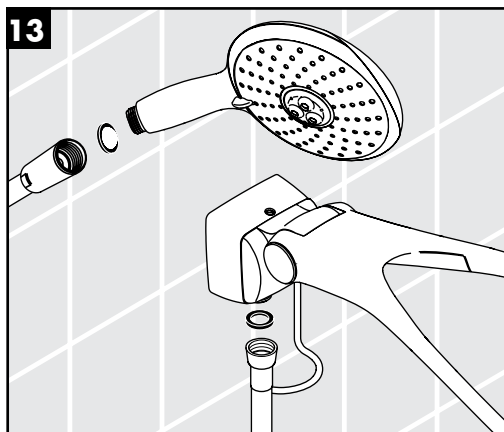
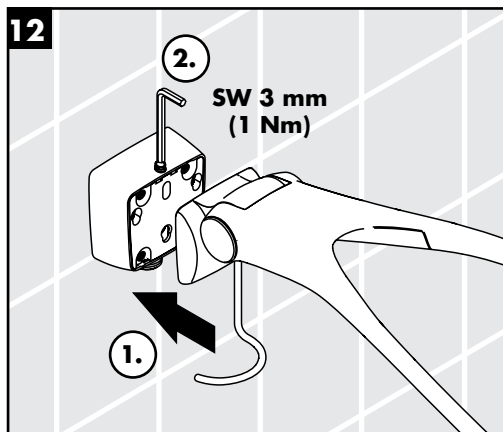
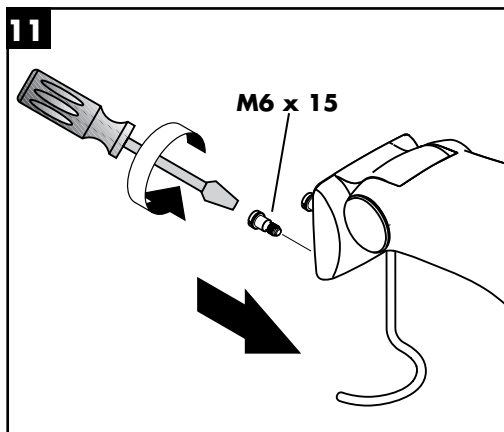



Raindance Allrounder Set

28110007

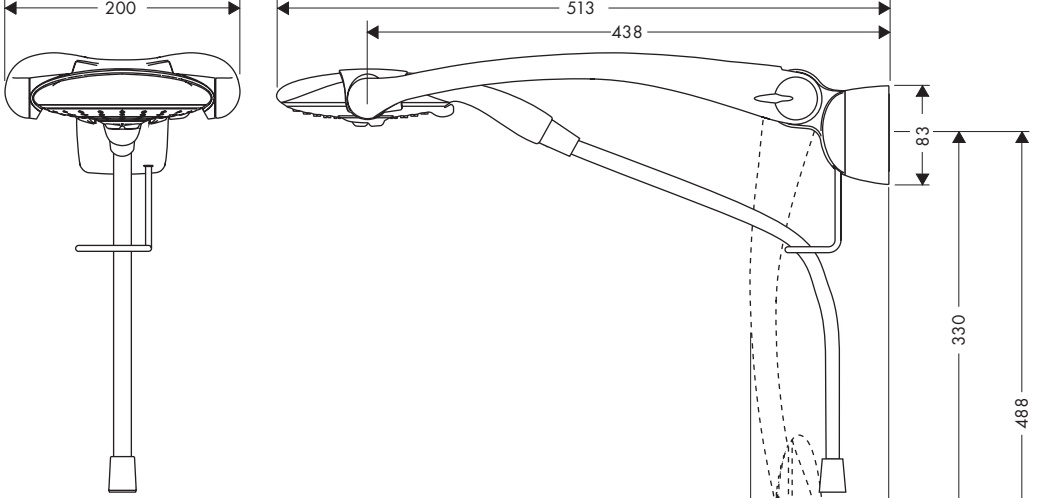

Raindance E 150 AIR 3jet

28518000

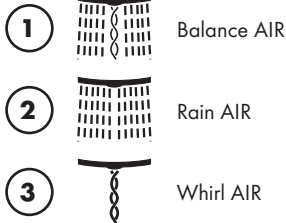
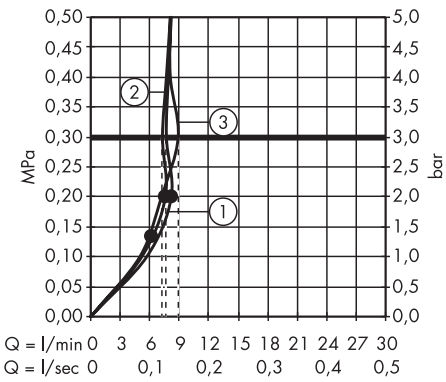
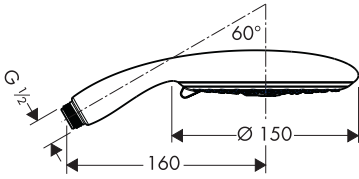

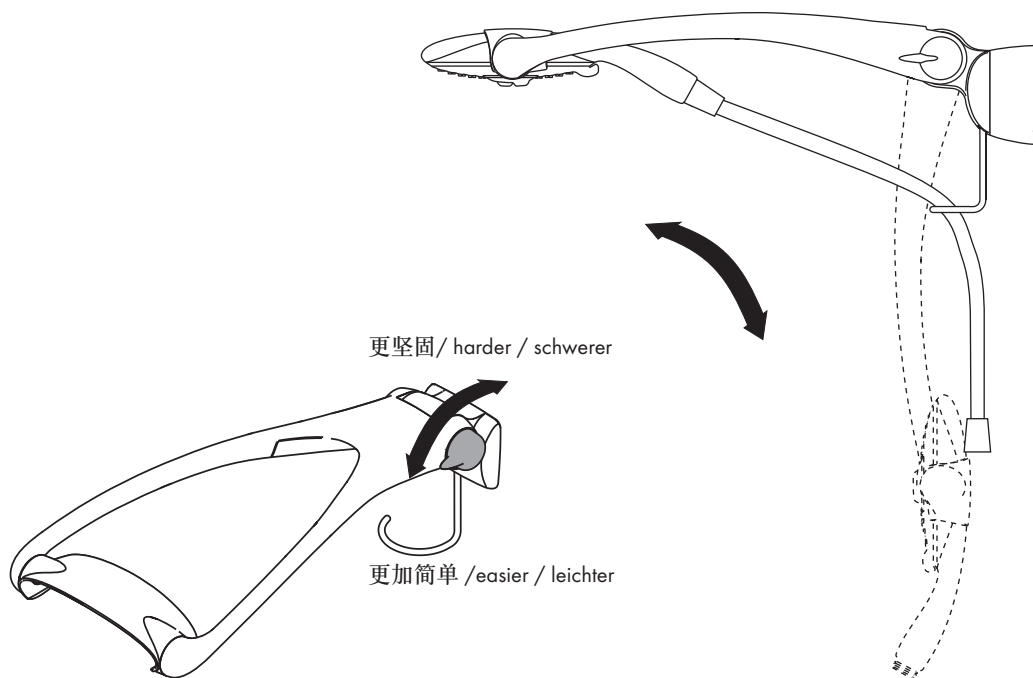
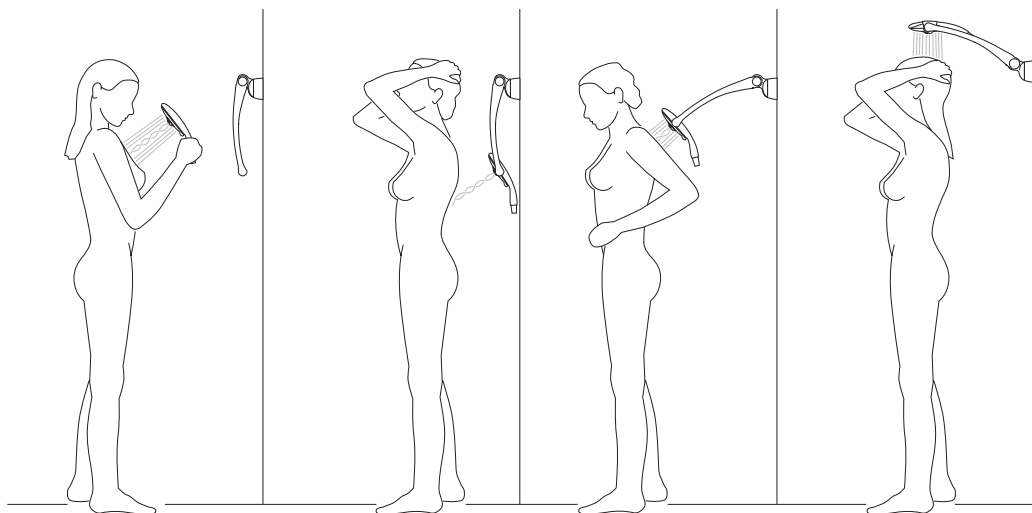

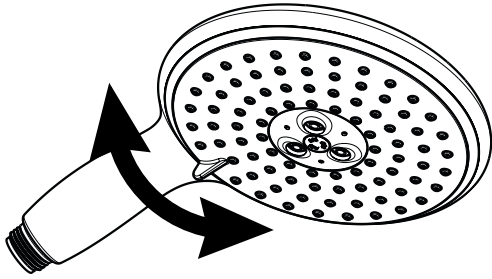

Raindance E 150 AIR 3jet

28518000



Balance AIR



Rain AIR



Whirl AIR

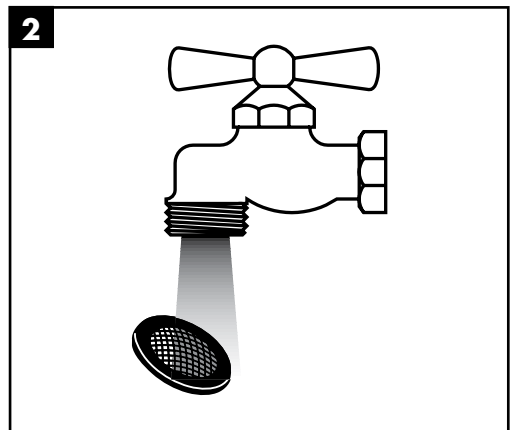
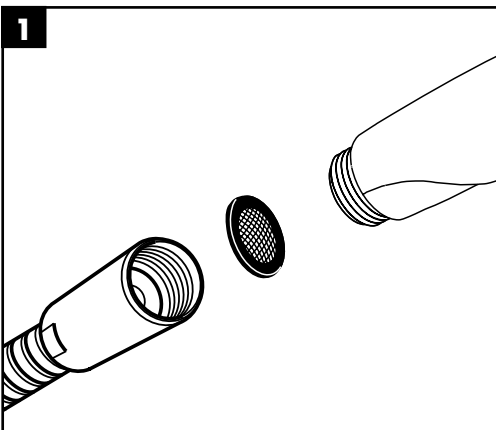
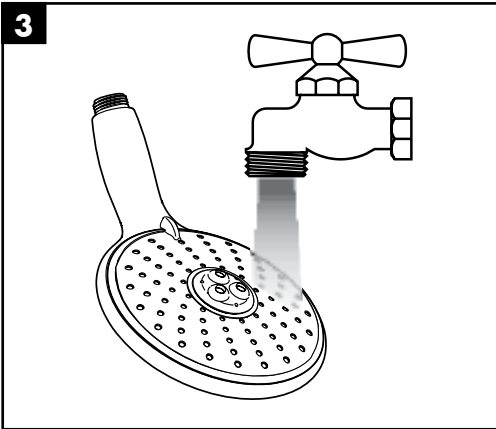
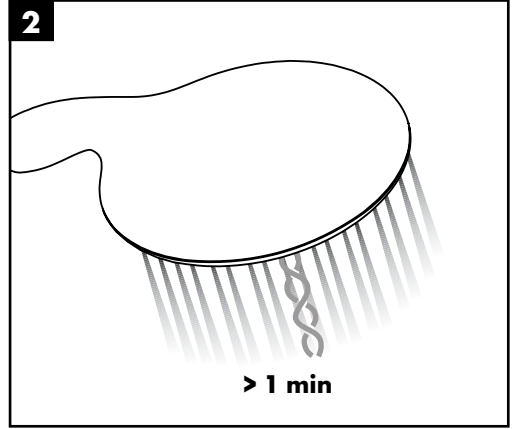
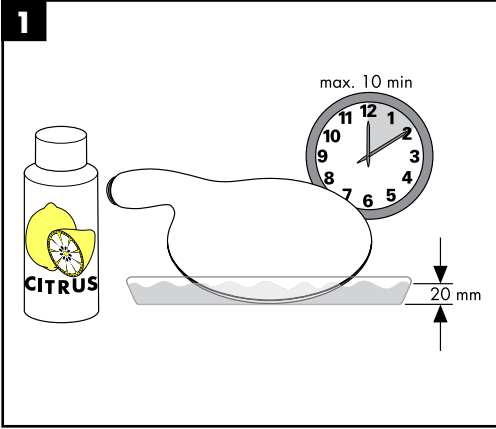



Raindance Allrounder Set

28110007

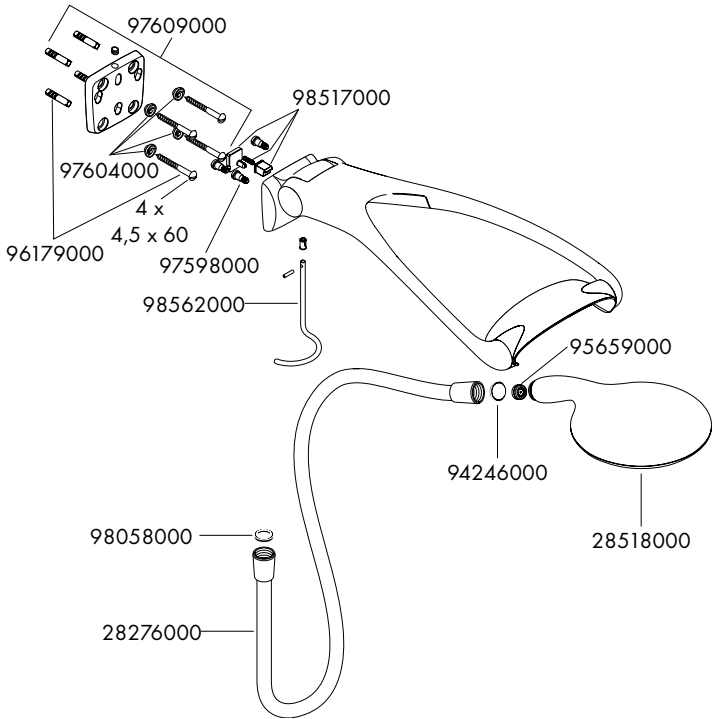

选装附件 / Special accessories / Sonderzubehör

28105000

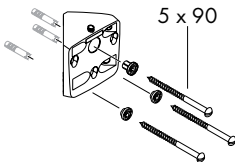

28108000

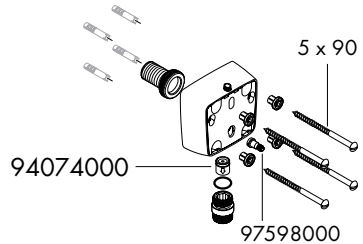



hansgrohe

Hansgrohe · Auestraße 5 - 9 · D-77761 Schiltach · Telefon +49 (0) 78 36/51-1282 · Telefax +49 (0) 7836/51 1440
E-Mail: info@hansgrohe.com · Internet: www.hansgrohe.com

4/2014
9.02525.01