

<b>EN</b>	Table of contents	<b>1</b>
	Instructions for use / assembly instructions	<b>2</b>
	Troubleshooting	<b>3</b>
	Assembly	<b>6 - 10</b>
	Adjustment	<b>11</b>
	Safety Function	<b>12</b>
	Operation	<b>13 - 14</b>
	Maintenance	<b>15 - 16</b>
	Cleaning	<b>17 - 18</b>
	Dimensions	<b>19</b>
	Flow diagram	<b>19</b>
	Spare parts	<b>20</b>
	Contact information	<b>20</b>
<b>SV</b>	Innehållsförteckning	<b>1</b>
	Bruksanvisning / Monteringsanvisning	<b>4</b>
	Felsökning	<b>5</b>
	Montering	<b>6 - 10</b>
	Inställning av maxtemperatur	<b>11</b>
	Safety Function	<b>12</b>
	Hantering	<b>13 - 14</b>
	Skötsel	<b>15 - 16</b>
	Rengöring	<b>17 - 18</b>
	Måttskiss	<b>19</b>
	Flödesschema	<b>19</b>
	Reservdelar	<b>20</b>
	Kontaktinformation	<b>20</b>

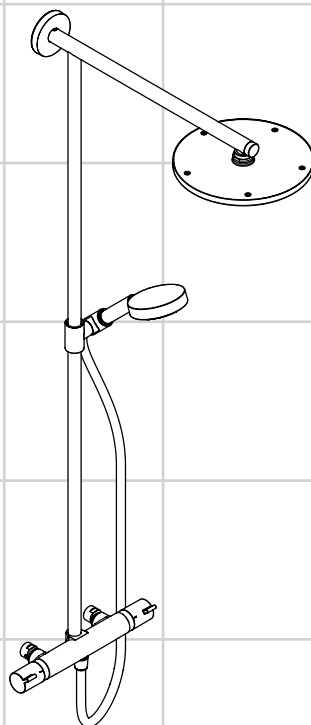

**Raindance Showerpipe**

27233000  
(RSK: 8126253)



**Ihr Online-Fachhändler für:**

**hansgrohe**

- Kostenlose und individuelle Beratung
- Hochwertige Produkte
- Kostenloser und schneller Versand

- TOP Bewertungen
- Exzelerter Kundenservice
- Über 20 Jahre Erfahrung



**E-Mail: [info@unidomo.de](mailto:info@unidomo.de) | Tel.: 04621 - 30 60 89 0 | [www.unidomo.de](http://www.unidomo.de)**



## Safety Notes

- ⚠ Gloves should be worn during installation to prevent crushing and cutting injuries.
- ⚠ The arm of the shower head is intended only to hold the shower head. Do not load it down with other objects!
- ⚠ Children as well as adults with physical, mental and/or sensoric impairments must not use this shower system without proper supervision. Persons under the influence of alcohol or drugs are prohibited from using this shower system.
- ⚠ Do not allow the streams of the shower touch sensitive body parts (such as your eyes). An adequate distance must be kept between the shower and you.
- ⚠ The product may not be used as a holding handle. A separate handle must be installed.
- ⚠ The shower system may only be used for bathing, hygienic and body cleaning purposes.
- ⚠ The hot and cold supplies must be of equal pressures.

## Installation Instructions

- Prior to installation, inspect the product for transport damages. After it has been installed, no transport or surface damage will be honoured.
- The product is not designed to be used with steam baths!
- The pipes and the fixture must be installed, flushed and tested as per the applicable standards.
- The plumbing codes applicable in the respective countries must be observed.
- The installation dimensions stated in these installation instructions are ideal for people of approximately 1800 mm in body height. The dimensions can be altered if required. In this case, pay attention to the fact that a change of installation height will also change the minimum height, and that the altered mounting dimensions must be taken into consideration.
- Where the contractor mounts the product, he should ensure that the entire area of the wall to which the mounting plate is to be fitted, is flat (no projecting joints or tiles sticking out), that the structure of the wall is suitable for the installation of the product and has

no weak points.

- The filter insert must be used to protect the shower against incoming dirt by pipework. Incoming dirt leads to defects or/and can damage parts of the shower; such caused faults voids all liability and guarantee claims.
- If required, the bottom part of the pipe between the fixture and the shower head can be shortened with a fine-toothed saw.

## Assembly (see page 6)

### Pressure and permeability test

- The connections of the thermostatic mixer should be tested regularly after installation.

### Technical Data

Operating pressure:	max. 1 MPa
Recommended operating pressure:	0,15 - 0,5 MPa
Test pressure:	1,6 MPa
(1 MPa = 10 bar = 147 PSI)	
Hot water temperature:	max. 70 °C
Recommended hot water temp.:	65 °C
Centre distance:	160 mm
Connections M 26x1,5:	cold right - hot left
Thermal disinfection:	max. 70 °C / 4 min

- Safety against backflow
- The product is exclusively designed for drinking water!



## Symbol description



Do not use silicone containing acetic acid!



### Adjustment (see page 11)

After the installation, the output temperature of the fitting must be tested and set to the temperate desired by the customer. Correction is necessary if the temperature measured at the take off point differs from the temperature set on the scale.

### max. Safety Function (see page 12)

≈ 42° C The desired maximum temperature for example max. 42° C can be pre-set thanks to the safety function.



### Maintenance (see page 15)

- The check valves must be checked regularly according to DIN EN 1717 in accordance with national or regional regulations (at least once a year).
- To guarantee the smooth running of the thermostat, it is necessary from time to time to turn the thermostat from total hot to total cold.

## Troubleshooting

Fault	Cause	Remedy
Insufficient water	- Supply pressure inadequate	- Check water pressure (If a pump has been installed check to see if the pump is working).
	- Filters are dirty (97367000)	- Cleaning the filter in the water connection and at the thermostat cartridge (97367000)
	- Shower filter seal dirty	- Clean filter seal between shower and hose
Crossflow, hot water being forced into cold water pipe, or vice versa, when mixer is closed	- Backflow preventers dirty or leaking	- Clean backflow preventers, exchange if necessary
Spout temperature does not correspond with temperature set	- Thermostat has not been adjusted	- Adjust thermostat
	- Hot water temperature too low	- Increase hot water temperature to 42 °C to 65 °C
Temperature regulation not possible	- thermo cartridge calcified	- Exchange thermo cartridge
Instantaneous heater didn't work with thermostat	- Filters are dirty	- Clean the filter / exchange filter
	- check valve hasn't moved back	- Exchange check valves



### Operation (see page 13)



### Cleaning (see page 17 and enclosed brochure)



### Dimensions (see page 19)



### Flow diagram

(see page 19)

- ① overhead shower
- ② Hand shower



### Spare parts (see page 20)



### Special accessories (order as an extra)

#98681000 tile-matching-disk chrome plated



**Assembly see page 6**



## ⚠ Säkerhetsanvisningar

- △ Handskar ska bäras under monteringsarbetet så att man kan undvika kläm- och skärskadorgen werden.
- △ Armen som håller huvudduschen är bara konstruerad för detta; den får inte belastas med andra föremål!
- △ Barn samt vuxna med fysiska, psykiska eller sensoriska funktionshinder får inte använda duschsystemet ensamma. Personer som är påverkade av alkohol- eller droger får inte använda duschsystemet.
- △ Undvik att rikta duschstrålarna mot känsliga kroppsdelar (t. ex. ögonen). Det måste finnas ett tillräckligt stort avstånd mellan duschen och kroppen.
- △ Produkten får inte användas som handtag. Ett separat handtag måste monteras.
- △ Duschsystemet får bara användas till kroppshygien med bad och dusch.
- △ Stora tryckskillnader mellan anslutningarna för varmt och kallt vatten måste utjämnas.

## Monteringsanvisningar

- Det måste undersökas om produkten har transportskador innan den monteras. Efter monteringen accepteras inga transport- eller ytskiktsskador.
- Produkten är inte avsedd att användas tillsammans med ett ångbad!
- Ledningarna och blandaren måste monteras, spolas igenom och kontrolleras enligt de gällande normerna.
- De installationsriktlinjer som gäller i länderna ska följas.
- De monteringsmått som anges i monteringsanvisningen passar 1,80 m långa personer och måste eventuellt anpassas. Det är då viktigt att tänka på att den minsta höjden ändras när monteringshöjden blir en annan och att hänsyn måste tas till de ändrade anslutningsmått.
- När kvalificerad fackpersonal monterar produkten är det viktigt att tänka på att monteringsytan är plan i alla delar av arbetsytan (inga fogar som sticker ut eller klinkerförskjutningar), att väggkonstruktionen passar till montering av produkten samt att den inte har svaga punkter.

- Silpackningen som följer med duschen måste monteras för att undvika att smuts från ledningsnätet tränger in. Smuts som spolas in kan påverka funktionerna och/eller leda till skador på funktionsdelar i duschen. Hansgrohe fransäger sig allt ansvar för skador som kan härledas till detta.
- Om det behövs kan röret mellan blandare och huvuddusch kortas i den nedre delen med en fintandad såg.

## Montering (se sidan 6)

## Tryck och täthetsprov

- Termostatblandarens anslutningar skall täthetskontrolleras efter installationen.

## Tekniska data

Driftstryck:	max. 1 MPa
Rek. driftstryck:	0,15 - 0,5 MPa
Tryck vid provtryckning: (1 MPa = 10 bar = 147 PSI)	1,6 MPa
Varmvattentemperatur:	max. 70 °C
Rek. varmvattentemp.:	65 °C
Anslutningsmått:	160 mm
Anslutningar M 26x1,5:	kallt höger - varmt vänster
Termisk desinfektion:	max. 70 °C / 4 min

- Självspärr mot återflöde
- Produkten är enbart avsedd för dricksvatten!



## Symbolförklaring



Använd inte silikon som innehåller ättiksyra!



### Inställning av maxtemperatur (se sidan 11)

Efter monteringen måste blandarens uttemperatur kontrolleras och ställas in på den temperatur som kunden vill ha. En korrigering krävs när den uppmätta temperaturen vid tappstället avviker från den temperatur som är inställd på termostaten.

### max. Safety Function (se sidan 12)

≈ 42 °C

Med hjälp av Safety Function kan du ställa in den önskade maximaltemperaturen till exempelvis 42°C och så förhindra skällningsrisk för barn.



### Skötsel (se sidan 15)

- Backventilens funktion måste kontrolleras regelbundet enligt nationella eller regionala bestämmelser (DIN 1988 en gång per år) i enlighet med DIN EN 1717.
- För att garantera att termostaten ej kalkar igen, ska den regelbundet, en gång per vecka, konditioneras. Det sker genom att man några gånger snabbt slår om temperaturen från hett till kallt och tillbaka.



### Hantering (se sidan 13)



### Rengöring (se sidan 17 och medföljande broschyr)



### Måtten (se sidan 19)



### Flödesschema

(se sidan 19)

- ① Huvuddusch
- ② Handdusch



### Reservdelar (se sidan 20)



### Specialtillbehör (medföljer ej leveransen)

#98681000 Kakelutjämningsbricka krom

## Felsökning

### Störning

För lite vatten

### Orsak

- Vattentrycket är för lågt
- Smutsfiltren är igensmutsade (97367000)
- Silfiltret i duschen smutsigt

### Åtgärd

- Kontrollera ledningstryck
- Rengör smutsfilter i anslutningarna och på styrenheten (97367000)
- Rengör silfiltret mellan slangen och termostaten

Korsflöde – varmt vatten pressas vid avstängd ermostat in i kallvatteninloppet, och vice versa

- Backventil är igensmutsad eller otät

- Rengör backventil, byt ut om nödvändigt

Den faktiska vatten-temperaturen stämmer inte överens med den inställda

- Termostaten ställdes inte in
- Varmvattentemperaturen är för låg

- Justera termostaten

- Höj varmvattentemperaturen till mellan 42°C och 65°C

Temperaturen kan ej ställas in

- Termosensorn är igenkalkad

- Byt termosensorn

Varmvattenberedare slår ej på vid användning av termostaten

- Smutsfiltren är igensmutsade

- Rengör / byt smutsfilter

- Backventil är defekt

- Byt backventil



## Montering se sidan 6

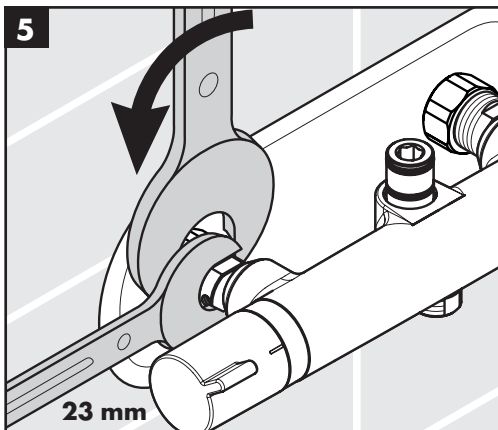
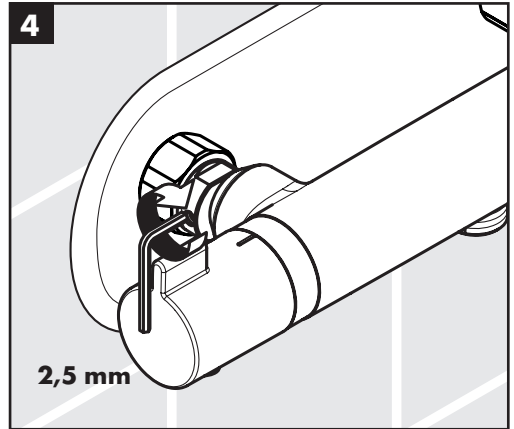
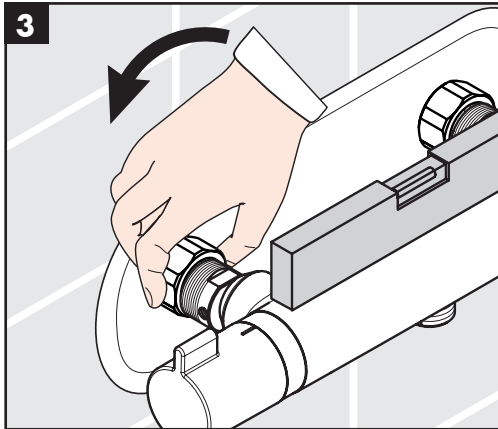
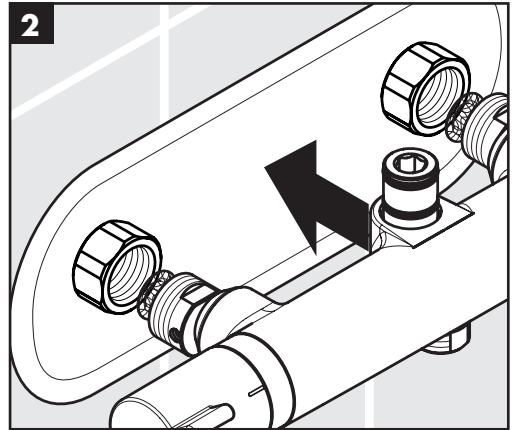
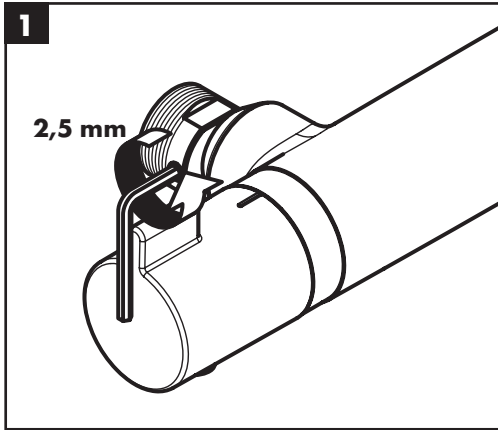

**The nuts of the installation plate must be tightened to the manufacturer's instructions.**

**Muttrarna dras åt enligt monteringsanvisningen från leverantören av blandarfäste.**

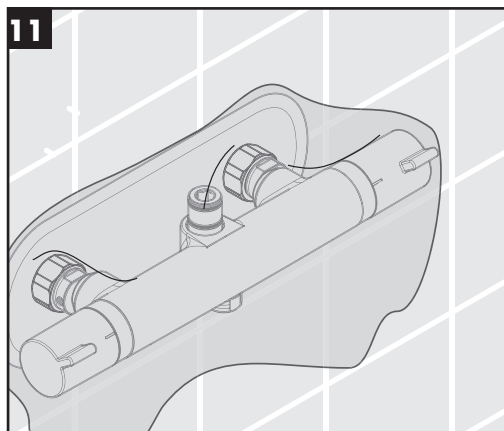
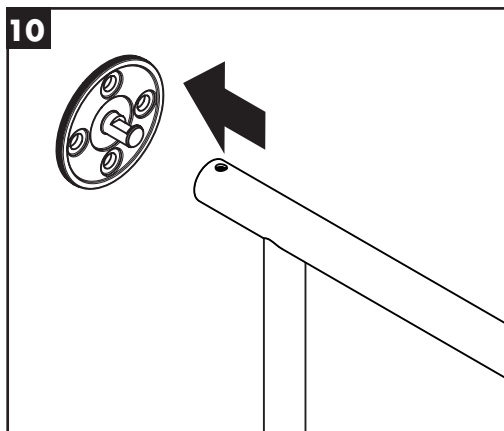
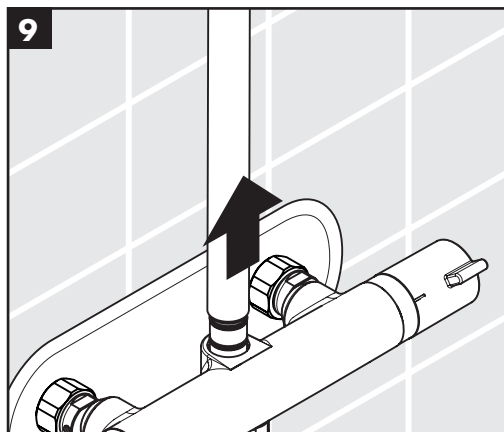
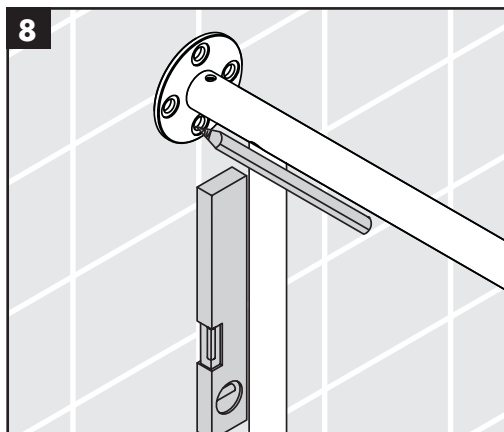
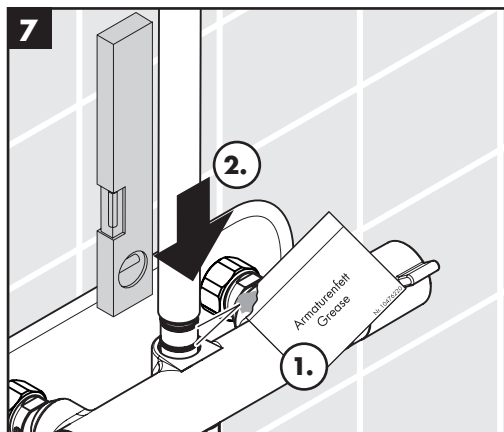
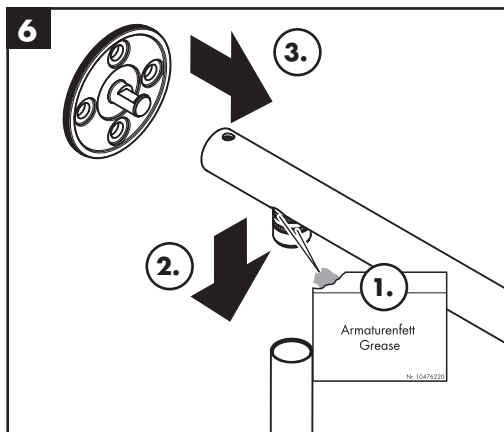



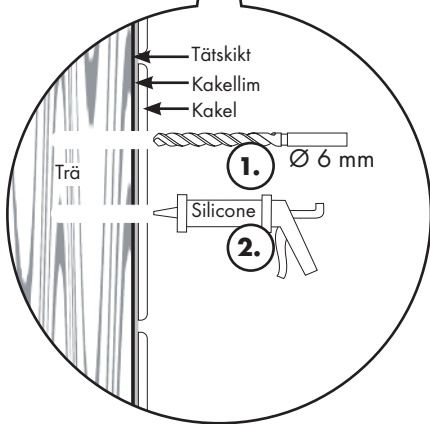
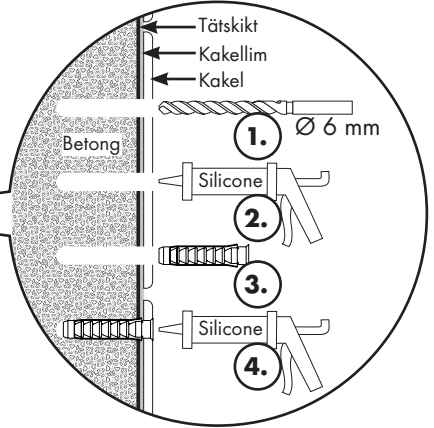
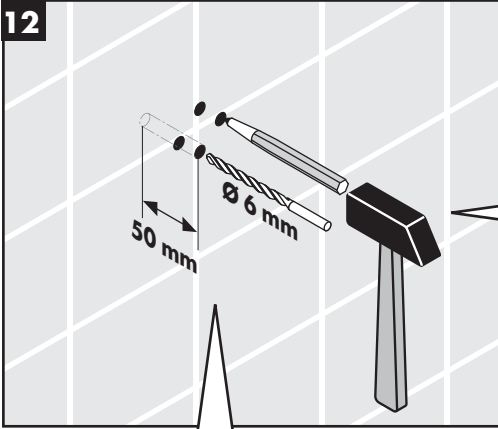

When installing on a stud wall, the wall must always be strengthened. All screws must be fixed to solid structures, such as concrete, studs or special structural components. Screws must not be fixed to flooring or wall sheets alone. Requirements for sealing apply in wet zones 1 and 2. Sealing materials must be fixed to the underlying layer and must be waterproof, mould-resistant and age-resistant.

Vid montering på regelvägg måste väggen alltid förstärkas. Alla skruvfästningar skall ske i massiv konstruktion, t.ex betong, i regler eller särskild konstruktionsdetalj. Skruvfästning får inte göras enbart i golvs- eller väggskiva. Krav på tätning gäller både i våtzon 1 och 2. Material för tätning ska fästa mot underlaget och vara vattenbeständigt, mögelresistent och åldersbeständigt.

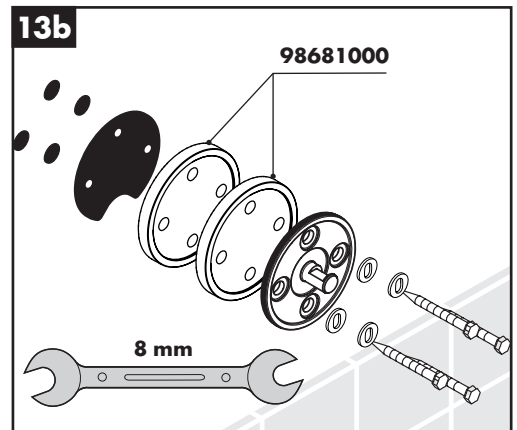
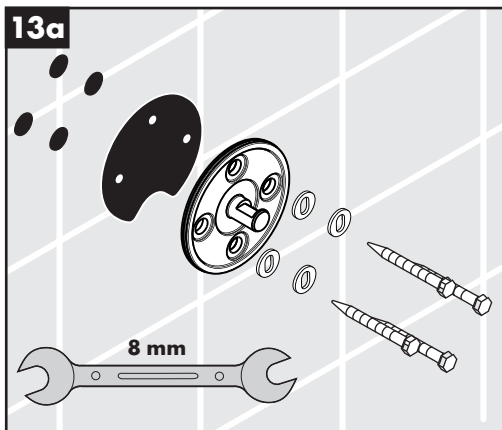

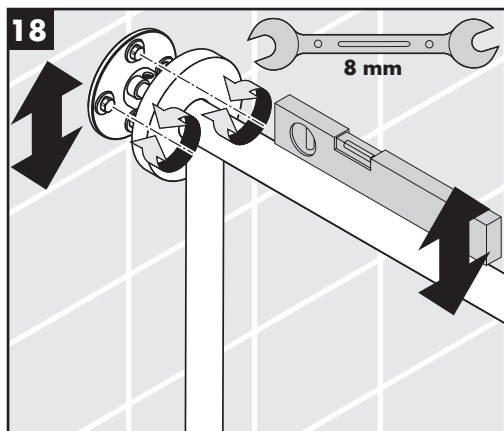
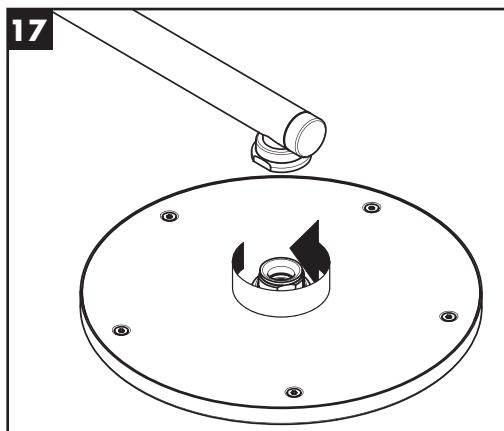
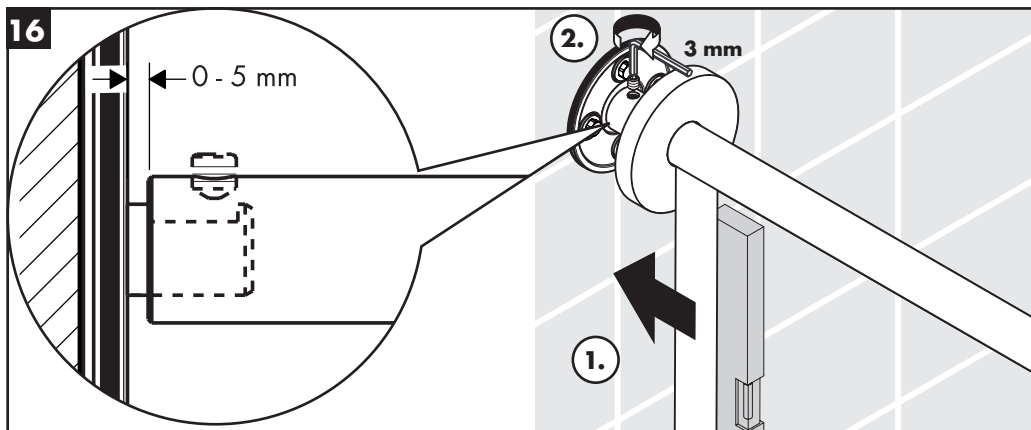
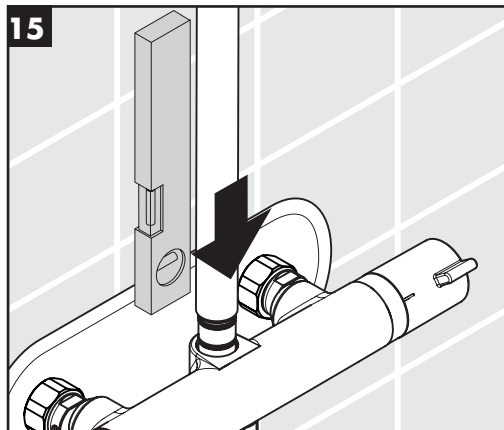
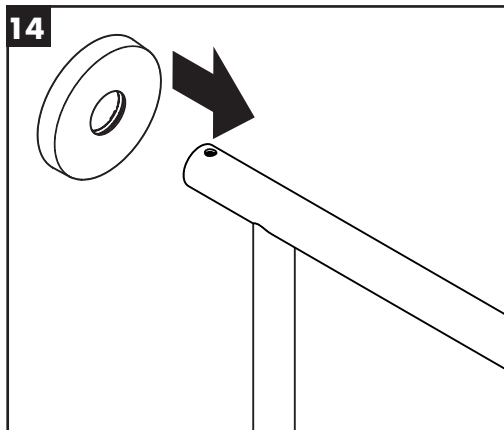

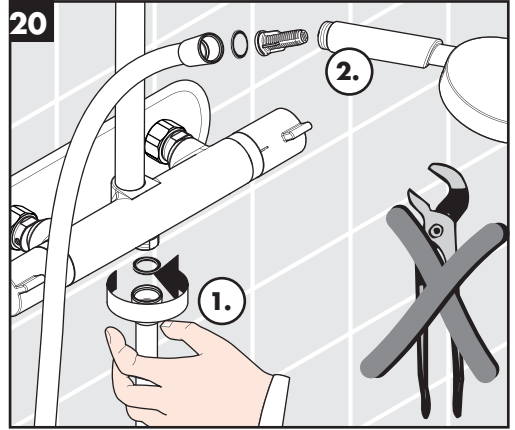
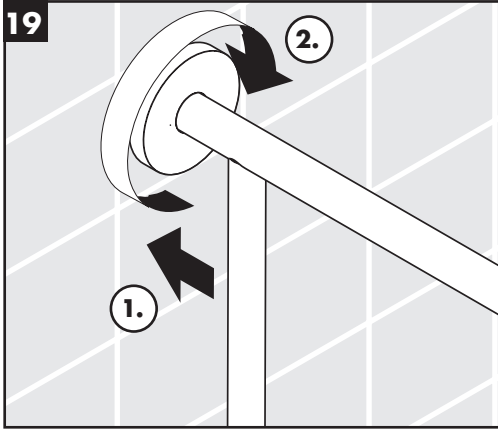

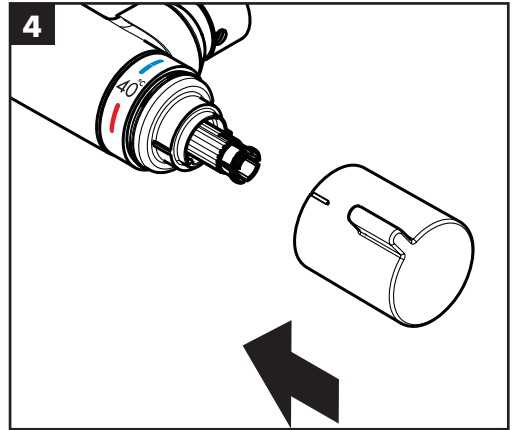
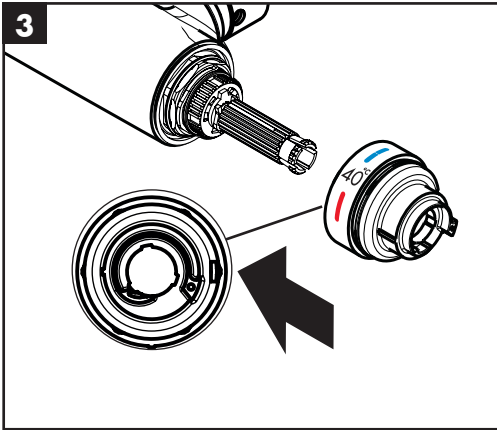
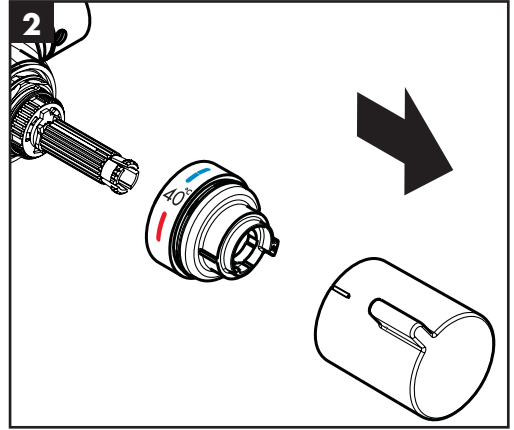
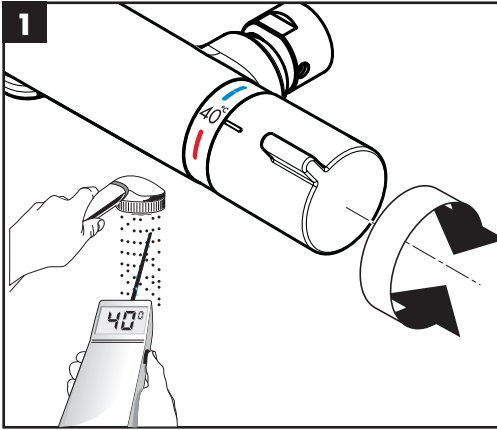

max.  
≈ 42° C

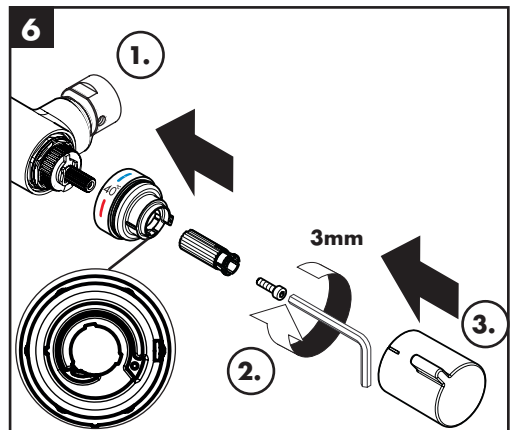
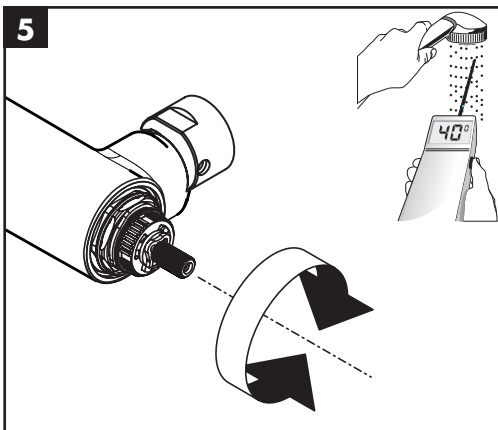
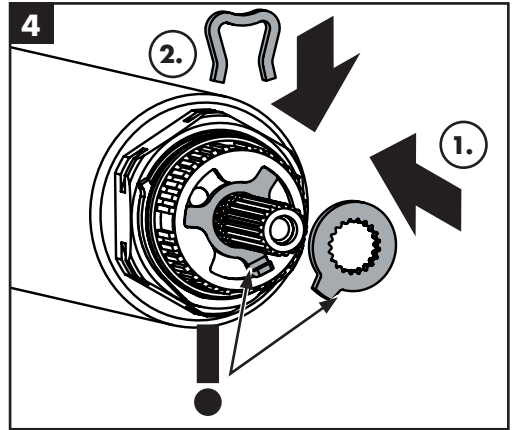
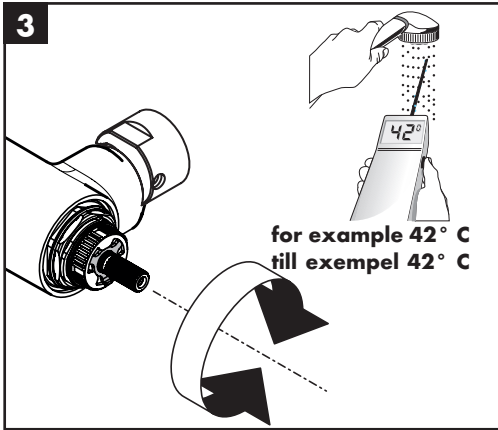
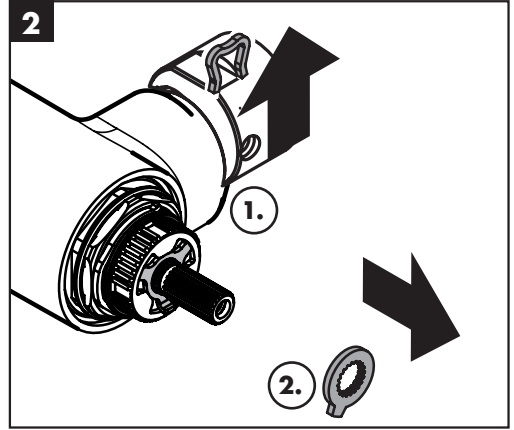
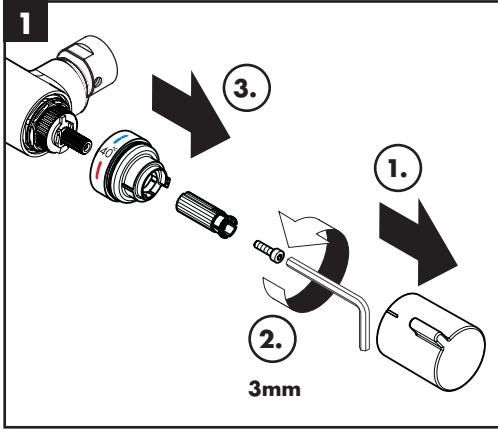

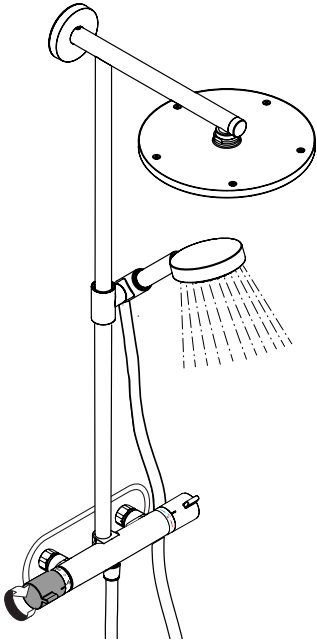

open / öppna

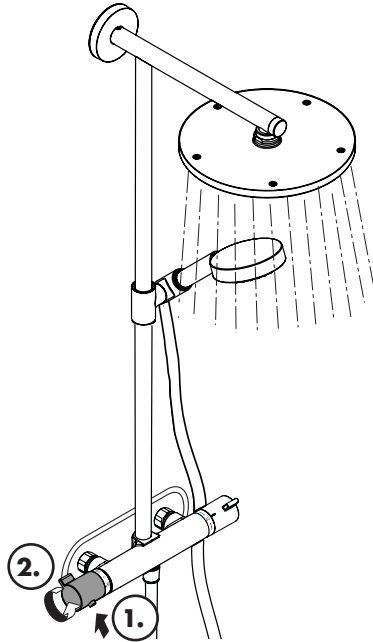

open / öppna

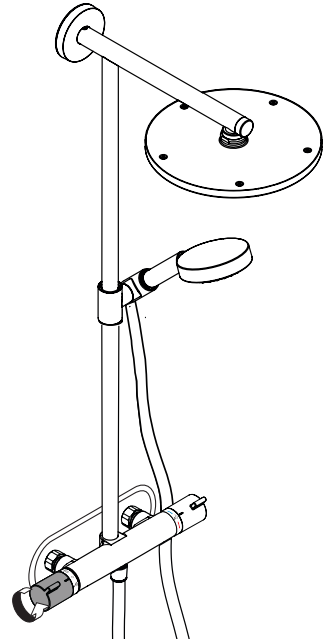

close / stänga

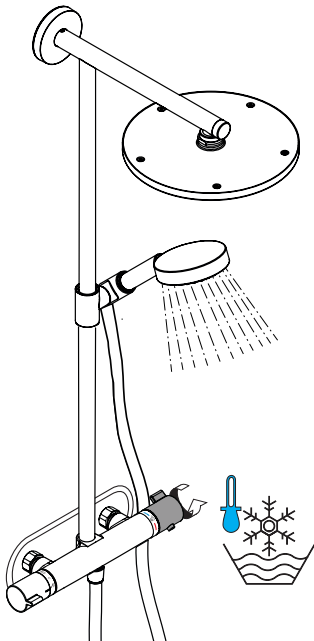

cold / kallt

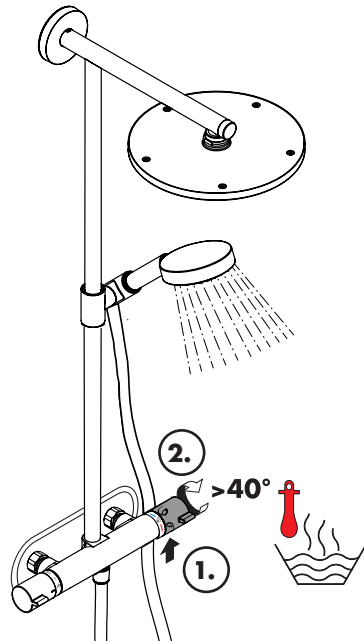

hot / varmt



## Raindance Select S 120 3jet

26530000

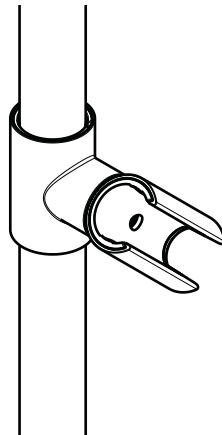
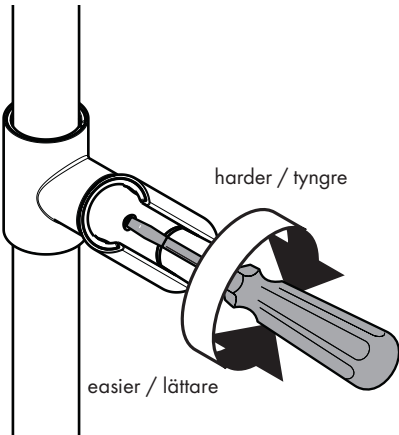
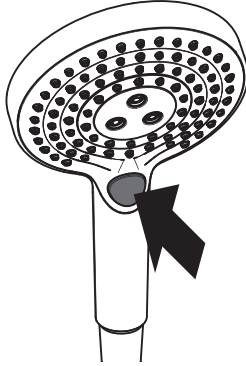

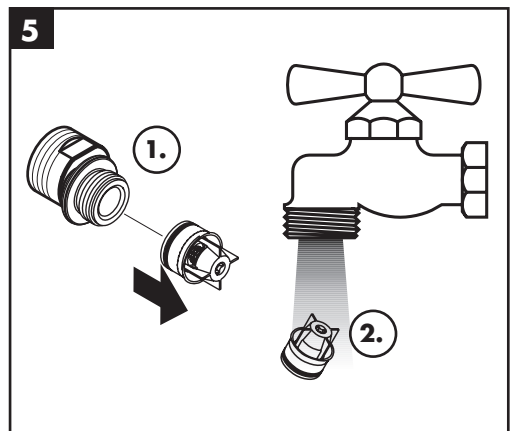
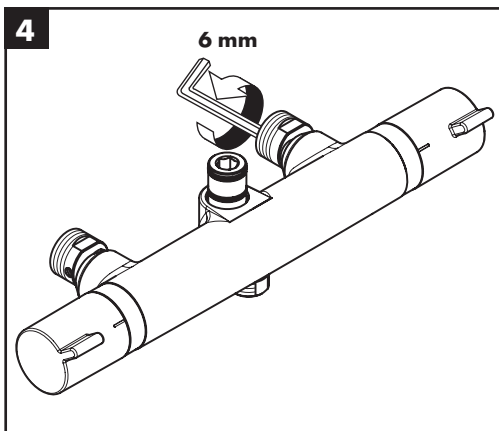
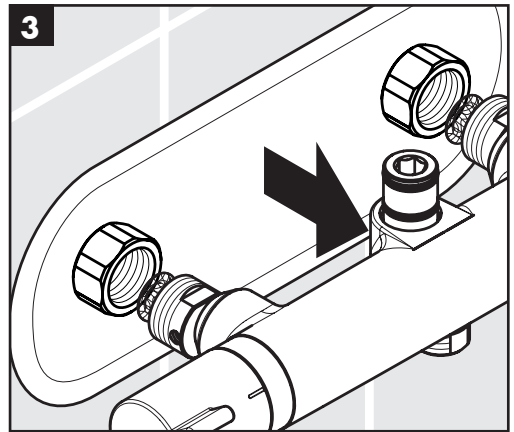
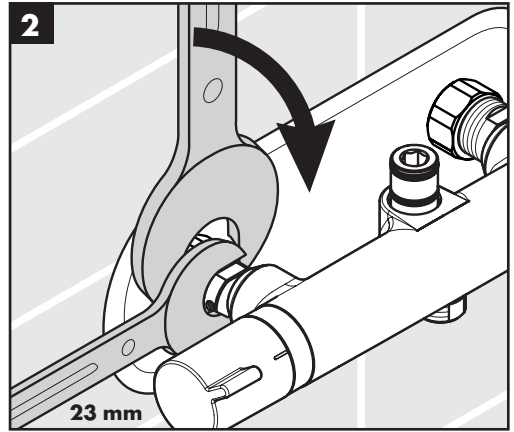
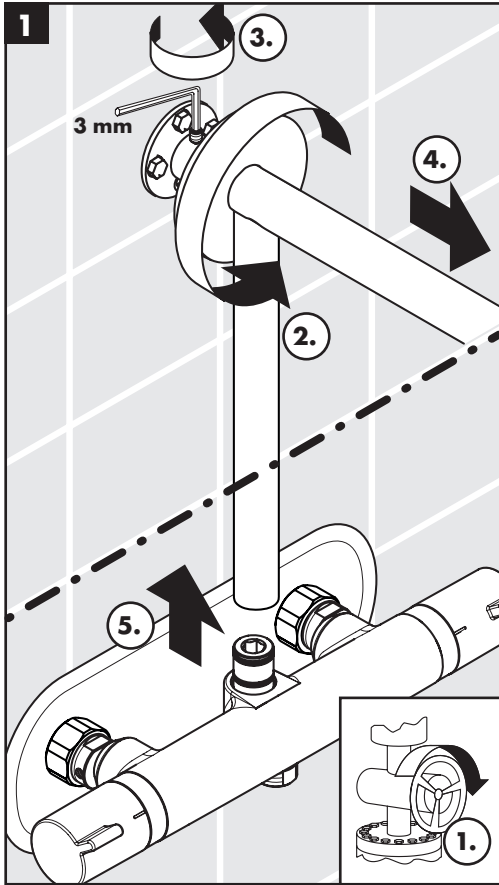



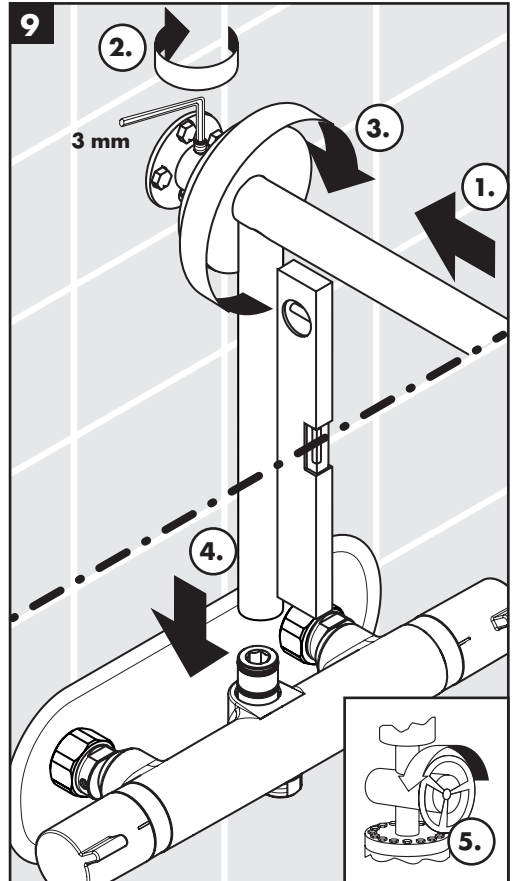
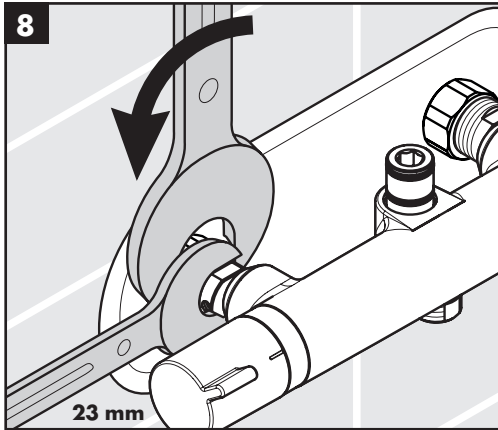
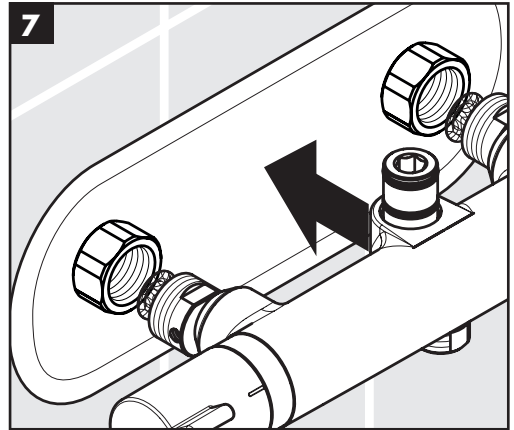
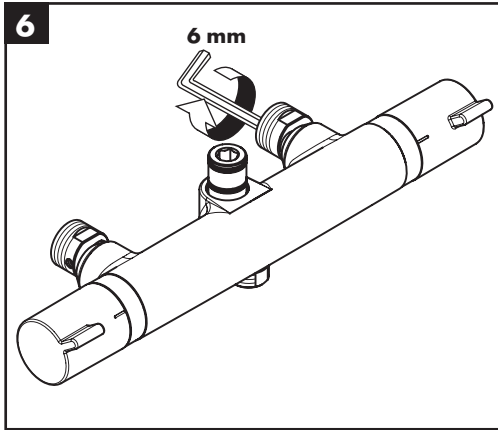

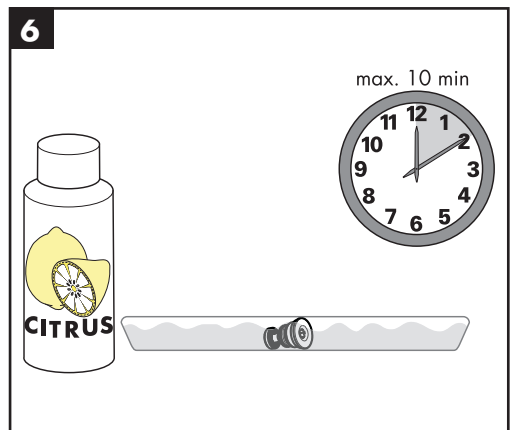
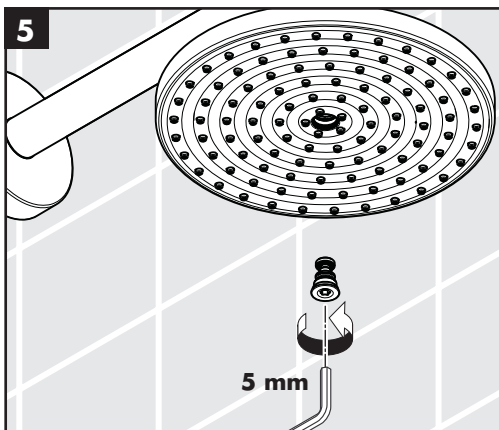
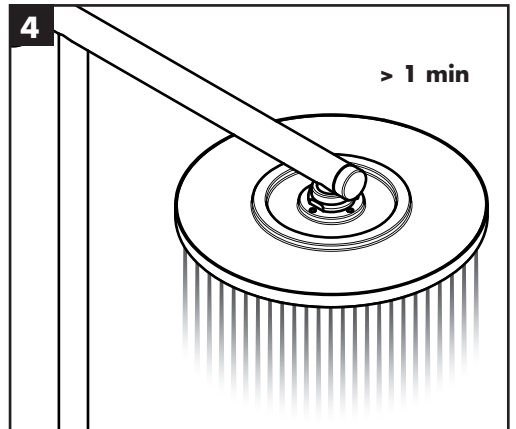
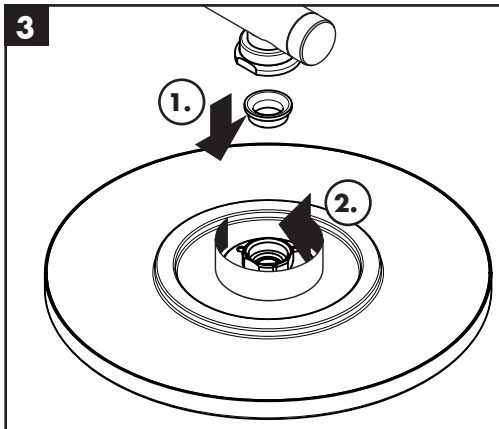
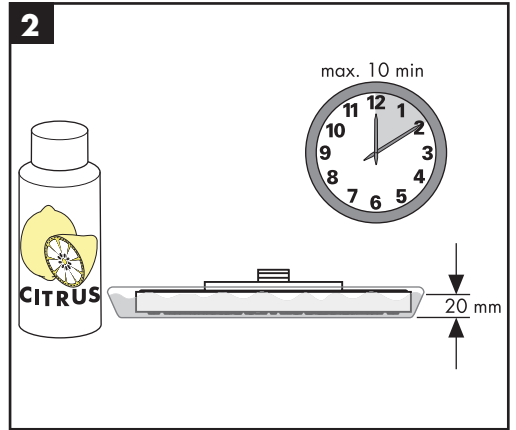
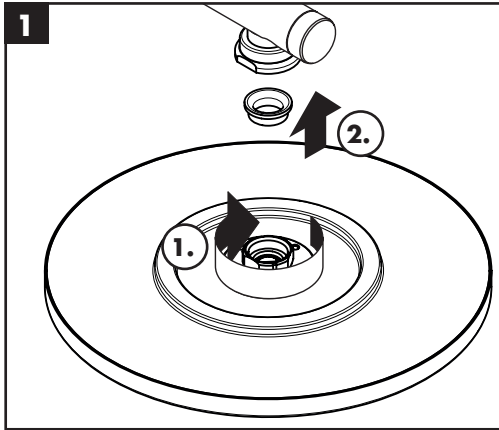

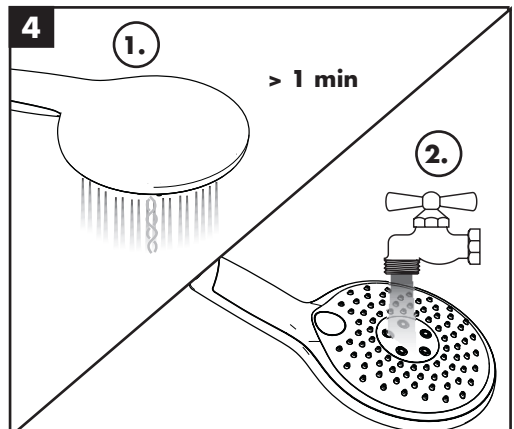
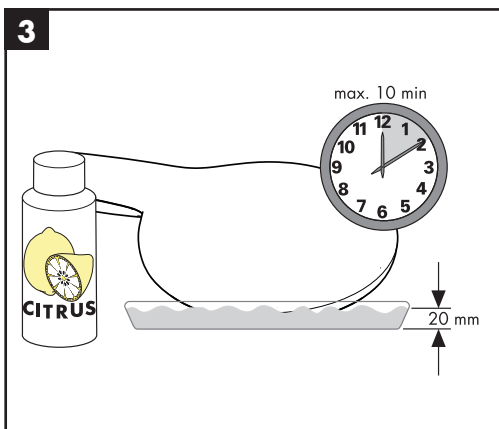
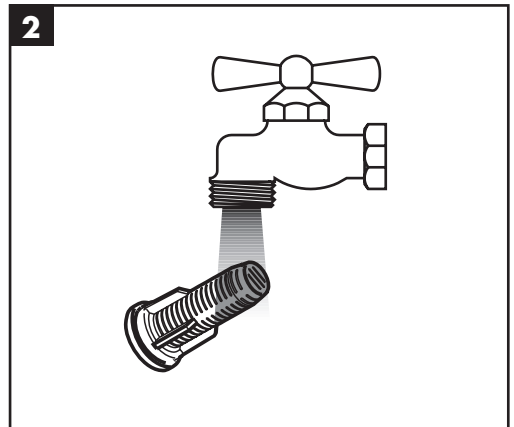
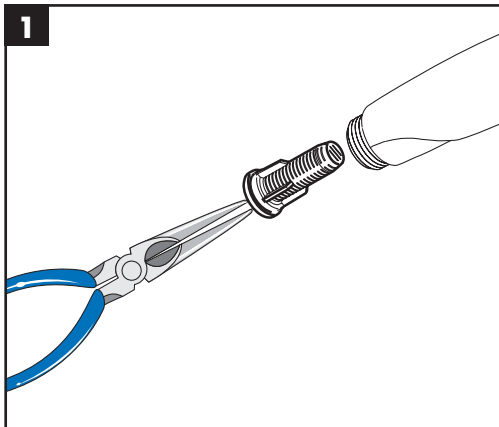
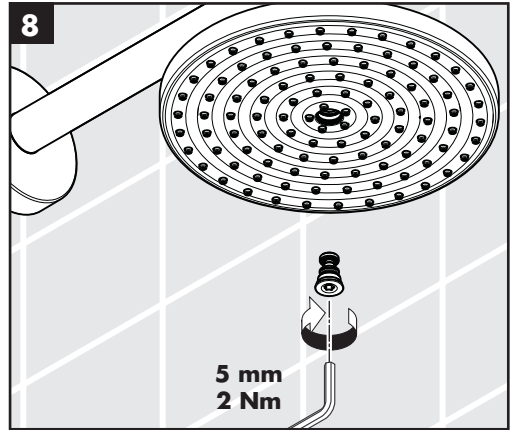
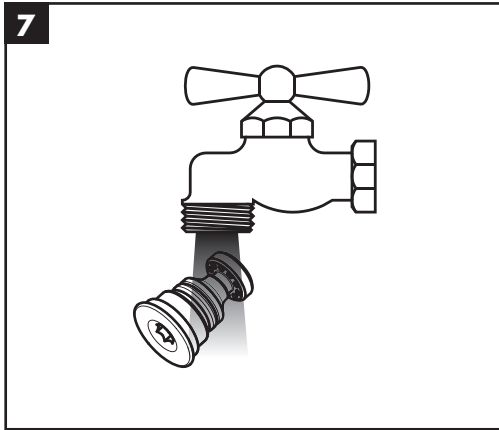

**Raindance Showerpipe**  
27233000

