

EN	Table of contents	1
	Instructions for use / assembly instructions	2
	Troubleshooting	3
	Assembly	6
	Adjustment	7
	Safety Function	8
	EcoStop	9
	Maintenance	10 - 11
	Operation	12 - 13
	Dimensions	14
	Flow diagram	14
	Spare parts	15
	Contact information	16
SV	Innehållsförteckning	1
	Bruksanvisning / Monteringsanvisning	4
	Felsökning	5
	Montering	6
	Inställning av maxtemperatur	7
	Safety Function	8
	EcoStop	9
	Skötsel	10 - 11
	Hantering	12 - 13
	Måttskiss	14
	Flödesschema	14
	Reservdelar	15
	Kontaktinformation	16

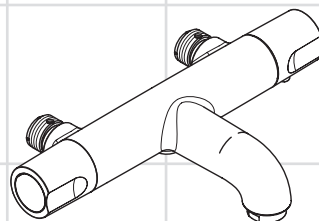

Ecostat 1001 SL

13242000

(RSK: 8310066)

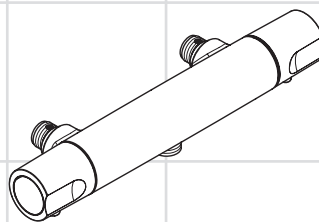

Ecostat 1001 SL

13274000

(RSK: 8310067)



Denna produkt är anpassad till branchregler Säkervatten-installation. Hansgrohe AB garanterar produktens funktion om branchreglerna och monteringsanvisningen följs.



Ihr Online-Fachhändler für:

hansgrohe

- Kostenlose und individuelle Beratung
- Hochwertige Produkte
- Kostenloser und schneller Versand



- TOP Bewertungen
- Exzelerter Kundenservice
- Über 20 Jahre Erfahrung



E-Mail: info@unidomo.de | Tel.: 04621 - 30 60 89 0 | www.unidomo.de



Safety Notes

-  Gloves should be worn during installation to prevent crushing and cutting injuries.
-  The shower system may only be used for bathing, hygienic and body cleansing purposes.

Installation Instructions

- Prior to installation, inspect the product for transport damages. After it has been installed, no transport or surface damage will be honoured.
- The product is not designed to be used with steam baths!
- The mixer must be installed, flushed and tested!

Assembly (see page 6)

Pressure and permeability test

- The connections of the thermostatic mixer should be tested regular after installation.

Technical Data

Operating pressure:	max. 1 MPa
Recommended operating pressure:	0,1 - 0,5MPa
Test pressure:	1,6MPa
(1 MPa = 10 bar = 147 PSI)	
Hot water temperature:	max. 80°C
Recommended hot water temp.:	65°C
Thermal disinfection:	max. 70°C / max. 4 min

- Safety against backflow
- The product is exclusively designed for drinking water!

Symbol description



Do not use silicone containing acetic acid!

max. Safety Function (see page 8)

≈ 42°C The desired maximum temperature for example max. 42°C can be pre-set thanks to the safety function.



Adjustment (see page 7)



After the installation, the output temperature of the thermostat must be checked. A correction is necessary if the temperature measured at the output differs from the temperature set on the thermostat.

ECO
≈ 10 l



ECOSTOP (see page 9)

Maintenance (see page 10)

-  To guarantee the smooth running of the thermostat, it is necessary from time to time to turn the thermostat from total hot to total cold.
-  The mixer is equipped with non return valves. The non return valves must be checked regularly according to DIN EN 1717 in accordance with national or regional regulations (at least once a year).



Operation (see page 12)

Dimensions (see page 14)



Assembly see page 6



Flow diagram
(see page 14)

- ① Shower
- ② Bath tub



Cleaning (see enclosed brochure)



Spare parts (see page 15)

Troubleshooting

Fault	Cause	Remedy
Insufficient water	- Supply pressure inadequate	- Check water pressure (If a pump has been installed check to see if the pump is working).
	- Filters are dirty (97367000)	- Clean filter in front of the mixer and on the MTC-thermo cartridge (97367000)
	- Shower filter seal dirty	- Clean filter seal between shower and hose
Crossflow, hot water being forced into cold water pipe, or vice versa, when mixer is closed	- Backflow preventers dirty or leaking	- Clean backflow preventers, exchange if necessary
Spout temperature does not correspond with temperature set	- Thermostat has not been adjusted	- Adjust thermostat
	- Hot water temperature too low	- Increase hot water temperature to 42 °C to 65 °C
Temperature regulation not possible	- thermo cartridge calcified	- Exchange thermo cartridge
Shower or spout dripping	- Dirt or sedimentation on valve seat, shut-off unit damaged	- Clean or exchange shut-off unit



Assembly see page 6



Säkerhetsanvisningar

- ⚠ Handskar skall bäras under monteringsarbetet så att kläm- och skärskador undviks.
- ⚠ Produkten får bara användas till kroppshygien med bad och dusch.

Monteringsanvisningar

- Det måste undersökas om produkten har transportskador innan den monteras. Efter monteringen accepteras inga transport- eller ytskiktsskador.
- Produkten är inte avsedd att användas tillsammans med ett ångbad!
- Armaturen måste installeras, genomspolas och testas.

Montering (se sidan 6)

Tryck och täthetsprov

- Termostatblandarens anslutningar skall täthetskontrolleras efter installationen.

Tekniska data

Driftstryck:	max. 1 MPa
Rek. driftstryck:	0,1 - 0,5MPa
Tryck vid provtryckning: (1 MPa = 10 bar = 147 PSI)	1,6MPa
Varmvattentemperatur:	max. 80 °C
Rek. varmvattentemp.:	65 °C
Termisk desinfektion:	max. 70 °C / max. 4 min

- Självspärr mot återflöde
- Produkten är enbart avsedd för dricksvatten!

Symbolförklaring



Använd inte silikon som innehåller ättiksyra!

max. Safety Function (se sidan 8)

≈ 42 °C

Med hjälp av Safety Function kan du ställa in den önskade maximaltemperaturen till exempelvis 42°C och så förhindra skållningsrisk för barn.



Inställning av maxtemperatur (se sidan 7)

När monteringen är klar måste termostatens tömningstemperatur kontrolleras. En justering är nödvändig om den uppmätta temperaturen vid tappningsstället avviker från den som är inställd på termostaten.

ECO
≈ 10 l



ECOSTOP (se sidan 9)

Skötsel (se sidan 10)

- ⚠ För att garantera att termostaten ej kalkar igen, ska den regelbundet, en gång per vecka, konditioneras. Det sker genom att man några gånger snabbt slås om temperaturen från hett till kallt och tillbaka.
- ⚠ Termostaten är utrustad med backventiler. Backventilers funktion måste kontrolleras regelbundet enligt nationella eller regionala bestämmelser i enlighet med DIN EN 1717 (minst en gång per år).

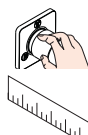

Hantering (se sidan 12)

Måtten (se sidan 14)



Montering se sidan 6



Flödesschema

(se sidan 14)

- ① Dusch
- ② Kar



Rengöring (se den medföljande broschyren)



Reservdelar (se sidan 15)

Felsökning

Störning	Orsak	Åtgärd
För lite vatten	- Vattentrycket är för lågt	- Kontrollera ledningstryck
	- Smutsfiltren är igensmutsade (97367000)	- Rengör smutsfiltren vid inloppen och på termosensorn (97367000)
	- Silfiltret i duschen smutsigt	- Rengör silfiltret mellan slangen och termostaten
Korsflöde – varmt vatten pressas vid avstängd ermostat in i kallvatteninloppet, och vice versa	- Backventil är igensmutsad eller otät	- Rengör backventil, byt ut om nödvändigt
Den faktiska vatten-temperaturen stämmer inte överens med den inställda	- Termostaten ställdes inte in	- Justera termostaten
	- Varmvattentemperaturen är för låg	- Höj varmvattentemperaturen till mellan 42°C och 65°C
Temperaturen kan ej ställas in	- Termosensorn är igenkalkad	- Byt termosensorn
Det droppar ur handdusch eller utloppspip till kar	- Smuts eller avlagringar på packningen, överdelen på avstängningsventilen är skadad	- Rengör eller byt överdelen av avstängningsventilen



Montering se sidan 6

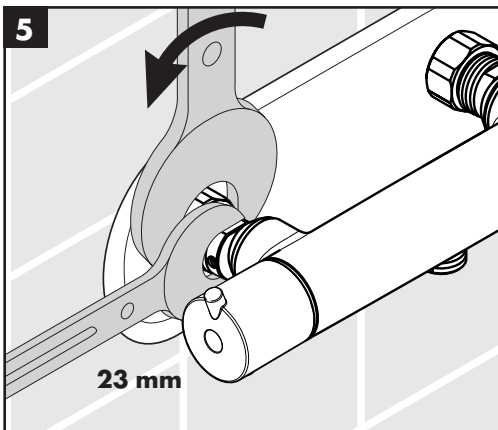
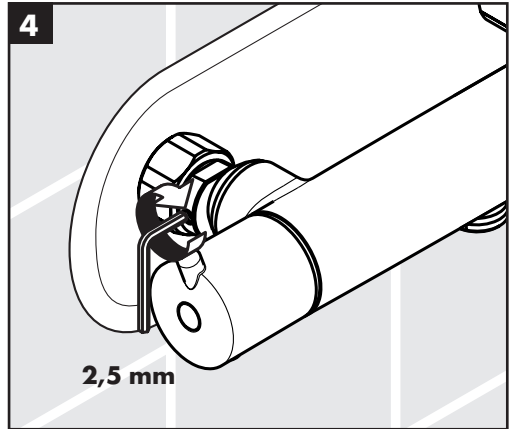
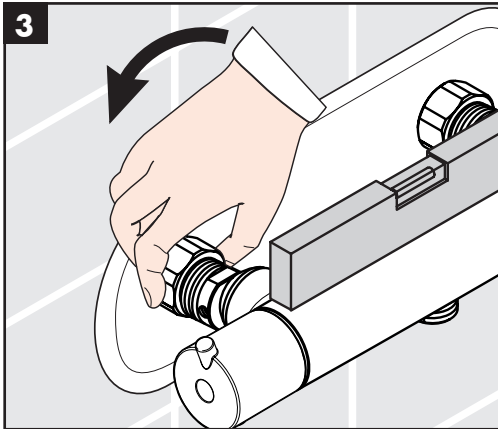
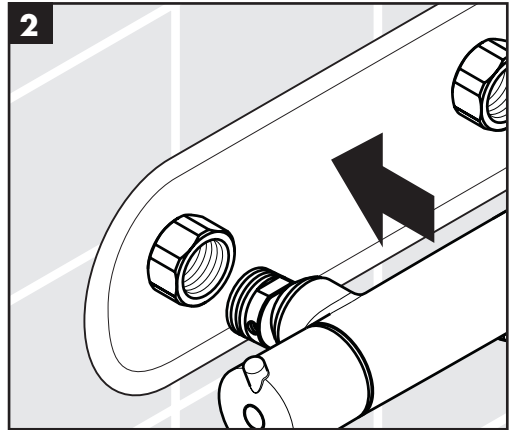
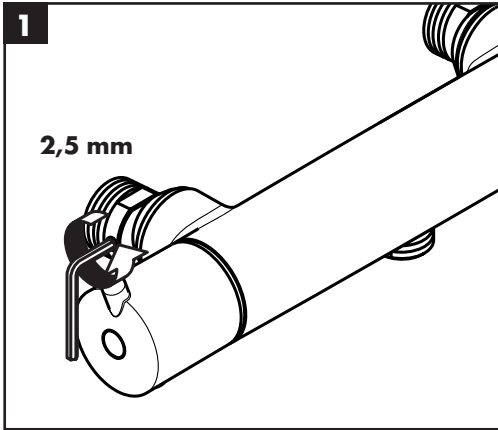

The nuts of the installation plate must be tightened to the manufacturer's instructions.

Muttrarna dras åt enligt monteringsanvisningen från leverantören av blandarfäste.

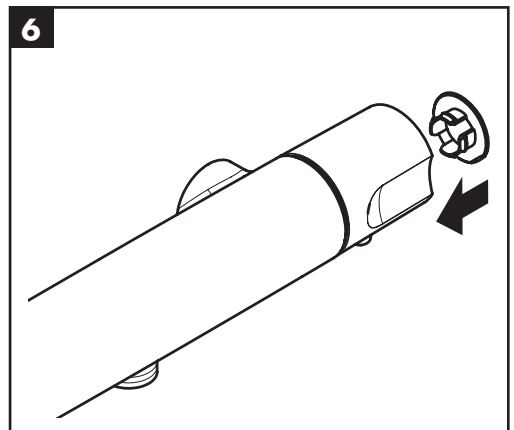
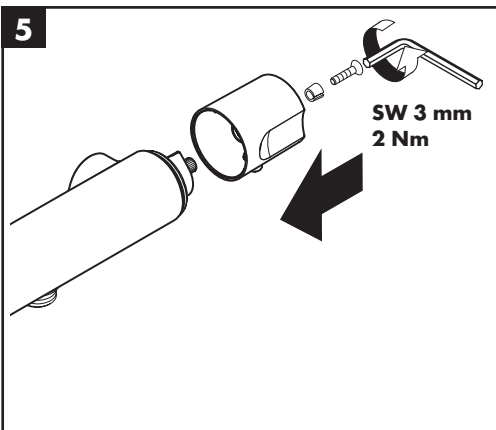
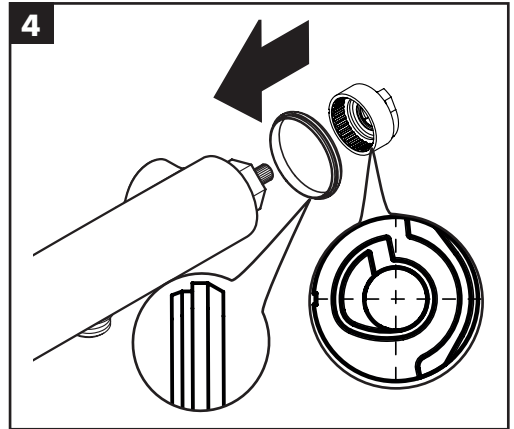
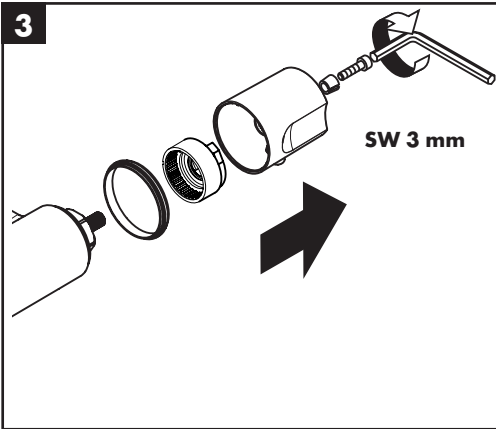
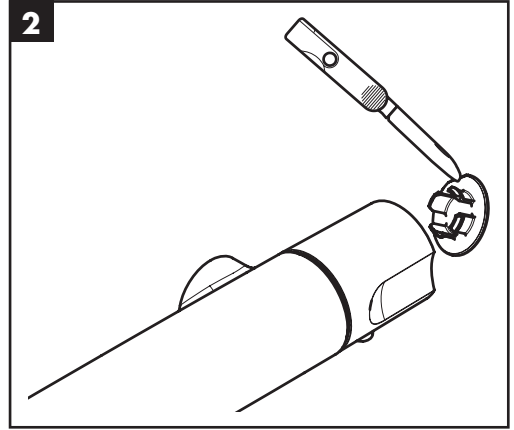
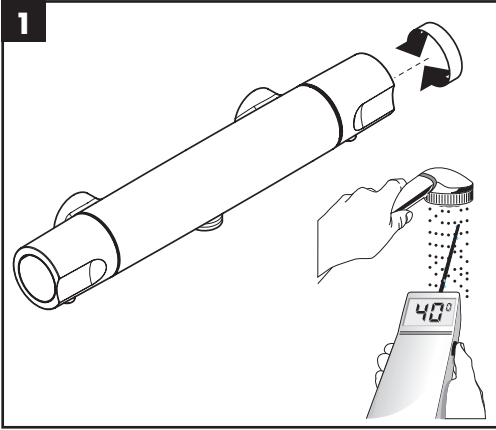

max.
≈ 42° C

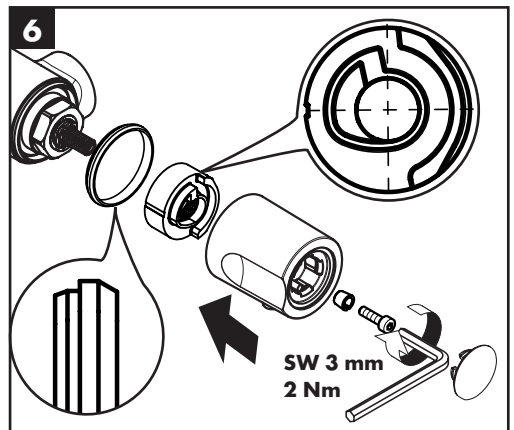
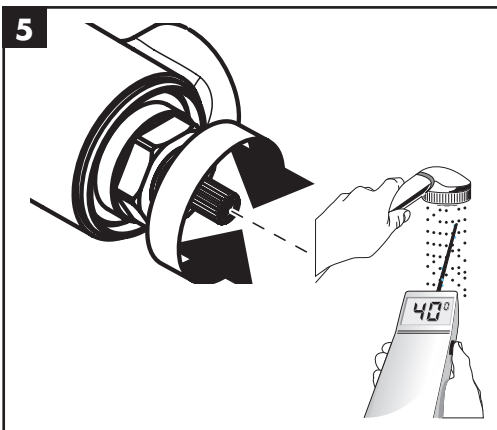
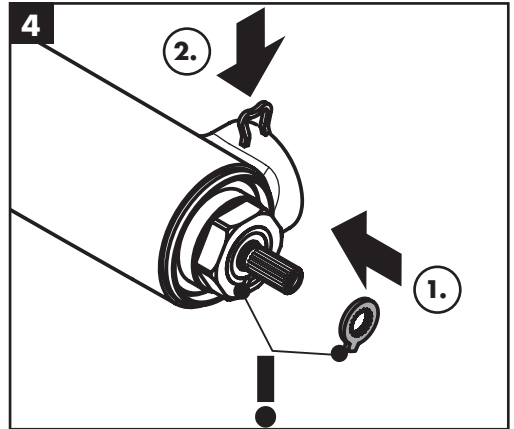
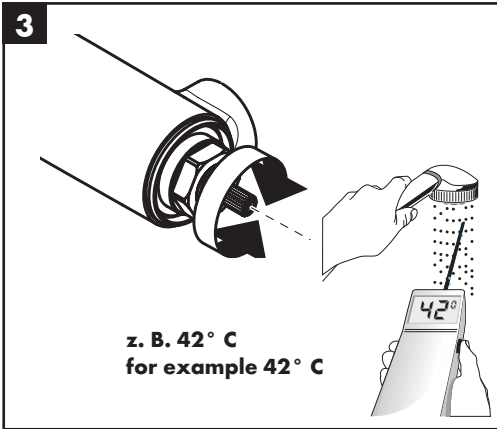
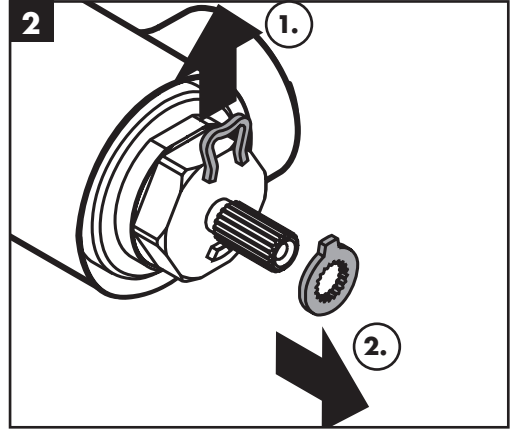
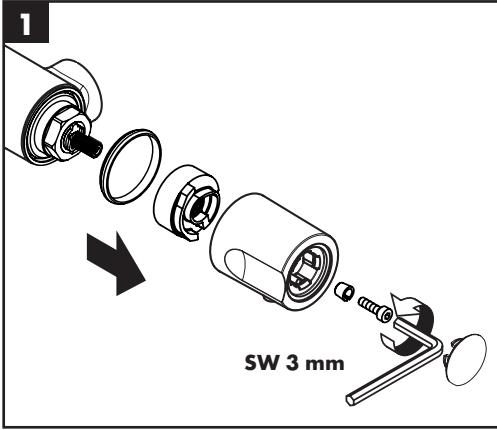

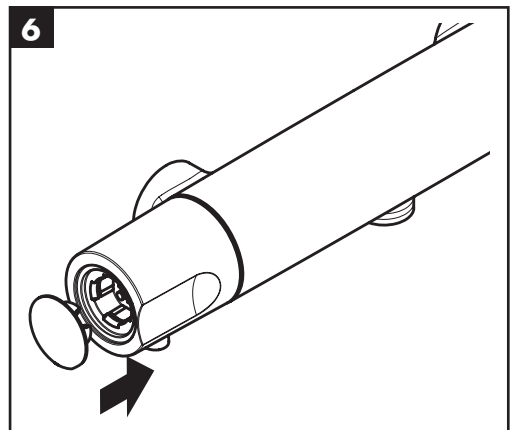
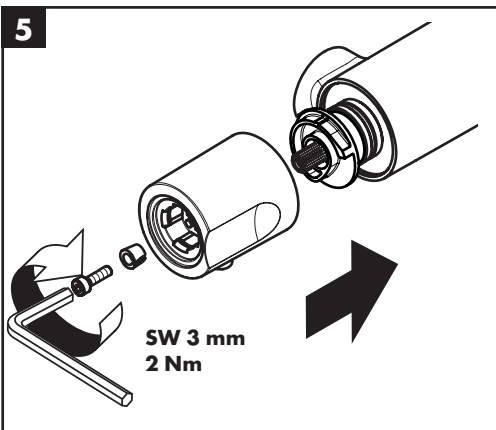
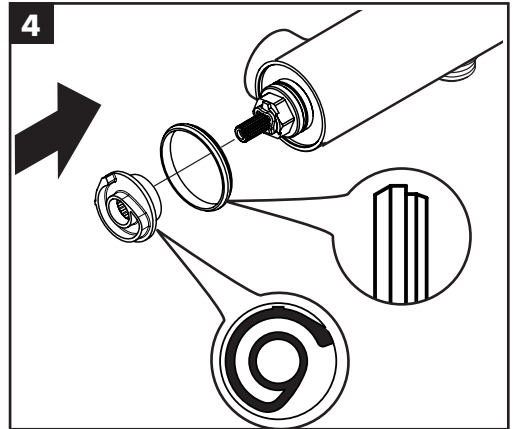
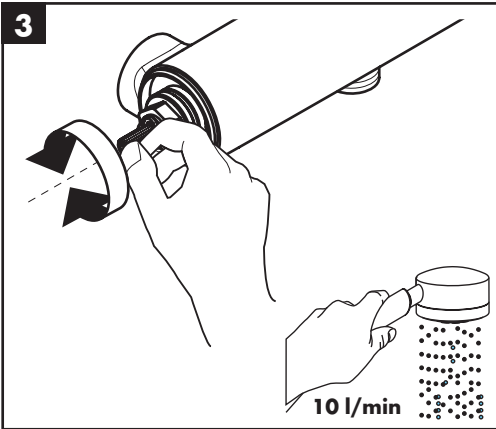
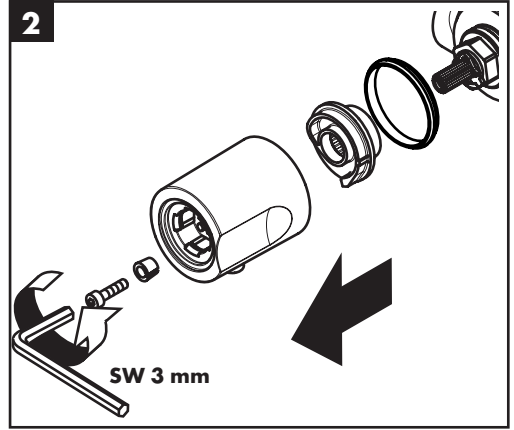
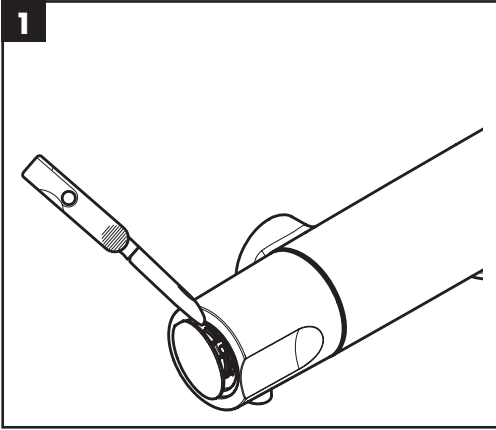

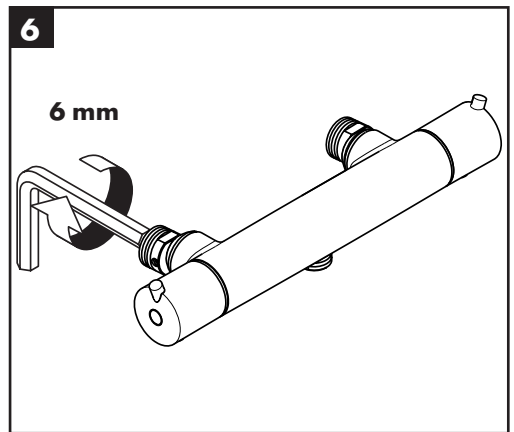
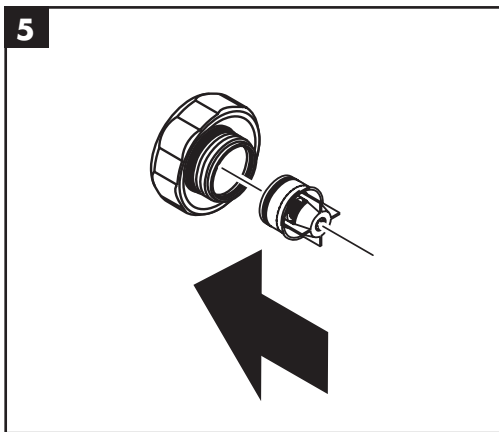
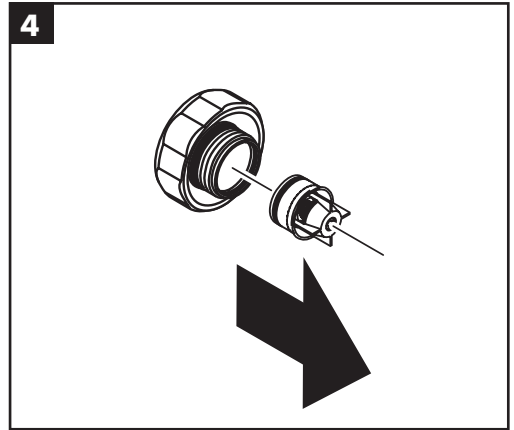
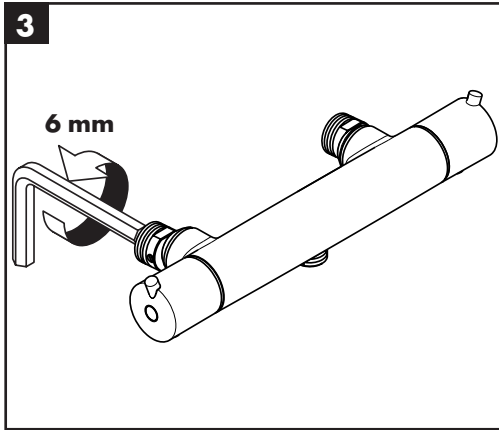
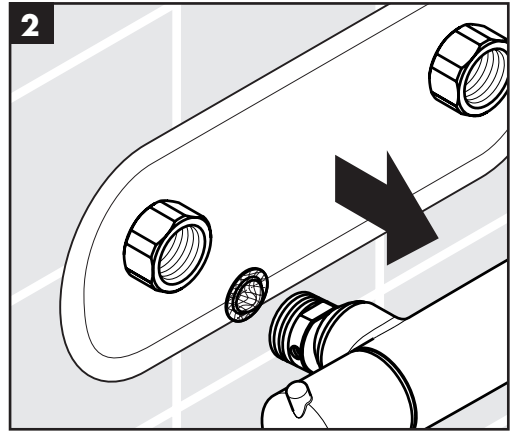
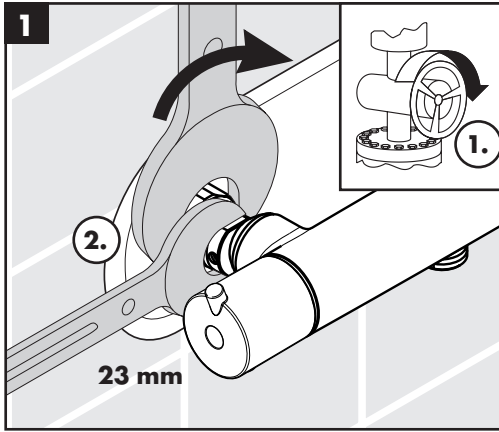

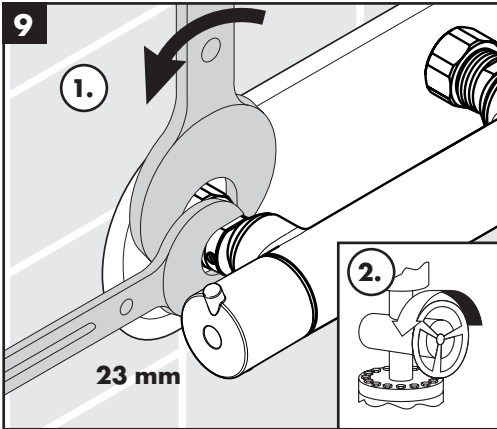
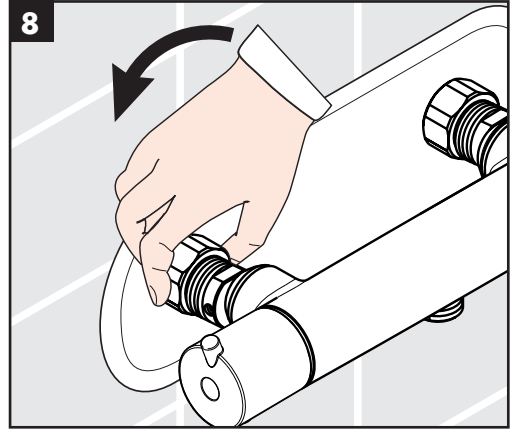
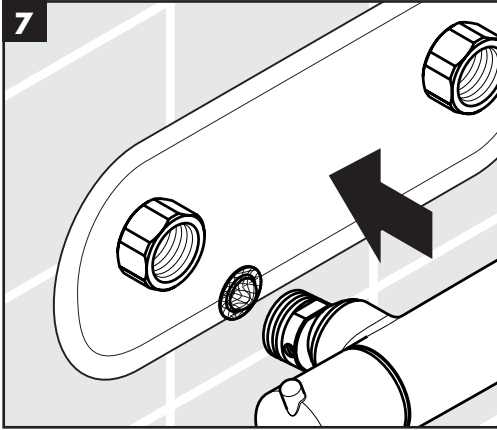

The nuts of the installation plate must be tightened to the manufacturer's instructions.

Muttrarna dras åt enligt monteringsanvisningen från leverantören av blandarfäste.

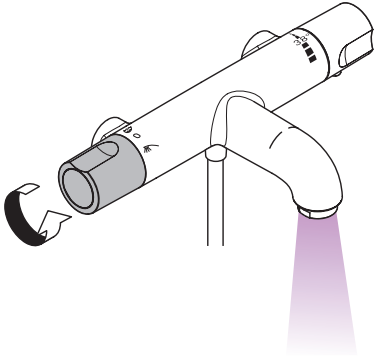

open / öppna

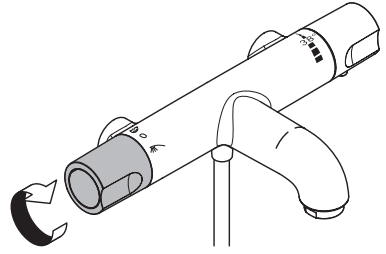

close / stänga

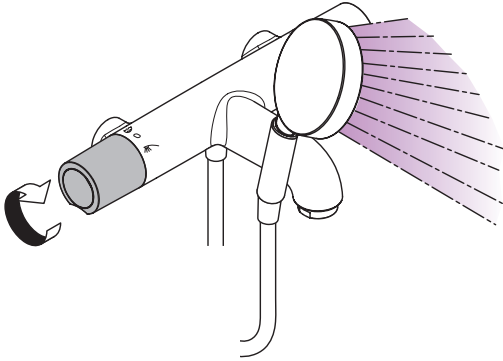

open / öppna

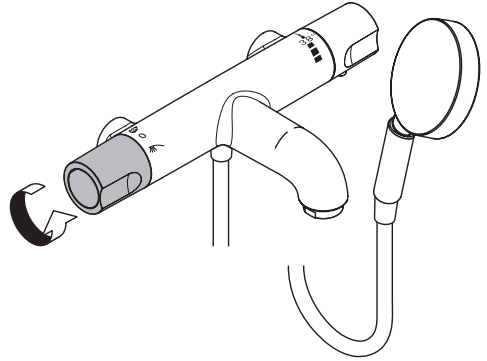

close / stänga

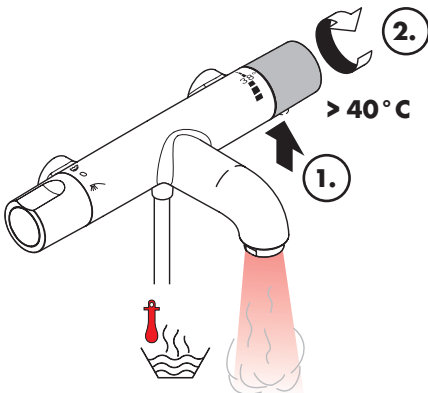

hot / varmt

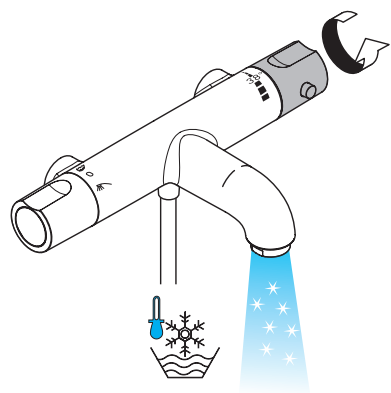

cold / kallt

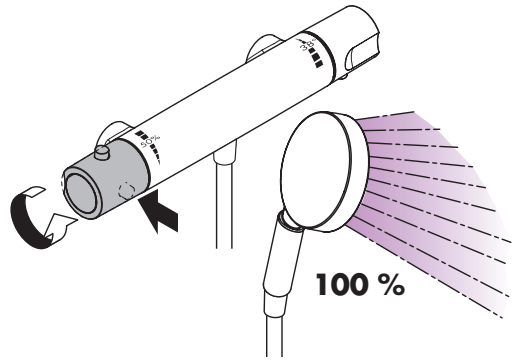
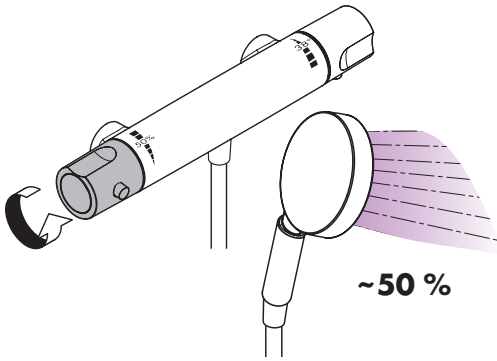

open / öppna

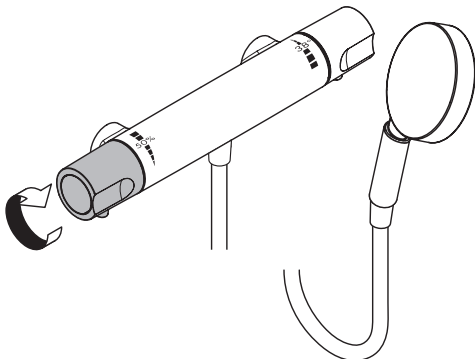

close / stänga

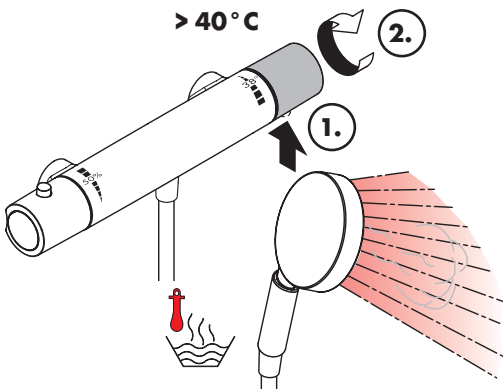

hot / varmt

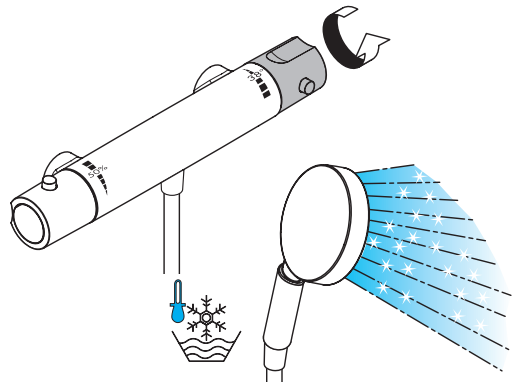

cold / kallt



Ecostat 1001 SL

13242000

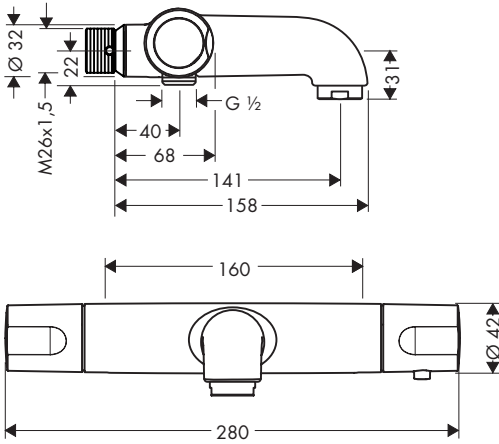

Ecostat 1001 SL

13274000

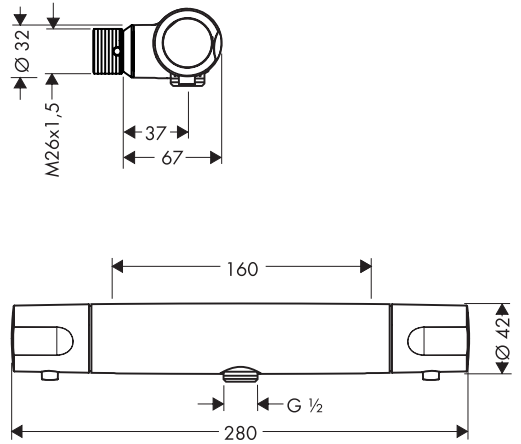

Ecostat 1001 SL

13242000

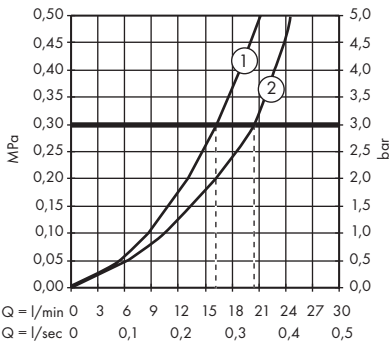

Ecostat 1001 SL

13274000

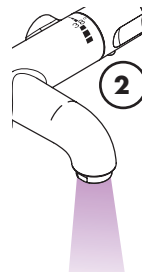
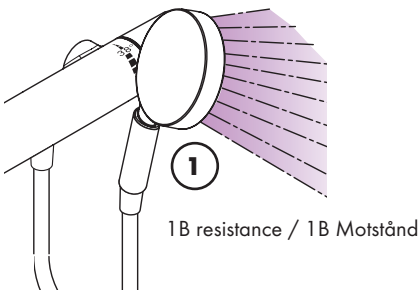
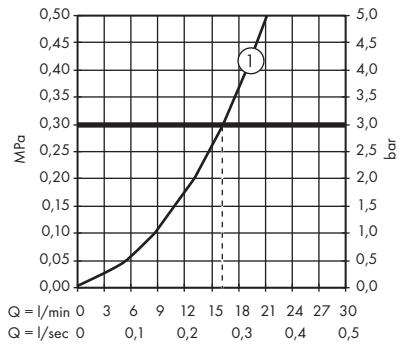



Ecostat 1001 SL
13242000

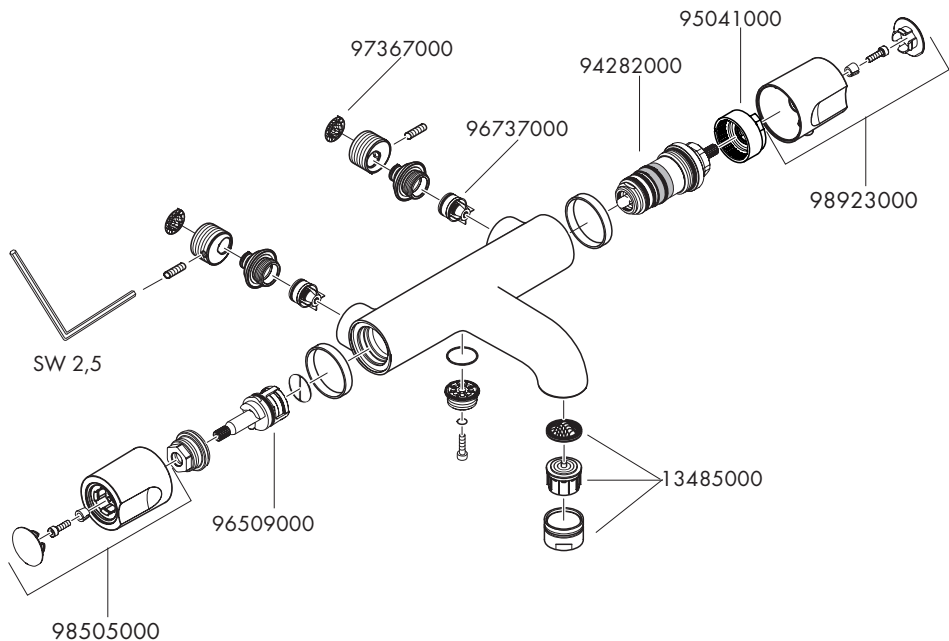

Ecostat 1001 SL
13274000

