

DE	Gebrauchsanleitung / Montageanleitung	2
FR	Mode d'emploi / Instructions de montage	3
EN	Instructions for use / assembly instructions	4
IT	Istruzioni per l'uso / Istruzioni per Installazione	5
ES	Modo de empleo / Instrucciones de montaje	6
NL	Gebruiksaanwijzing / Handleiding	7
DK	Brugsanvisning / Monteringsvejledning	8
RU	Руководство пользователя / Инструкция по монтажу	9

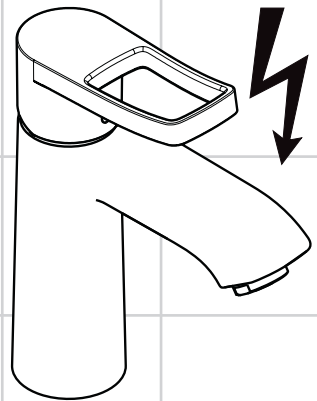

Mediano (2012)

14512000



Ihr Online-Fachhändler für:

hansgrohe

- Kostenlose und individuelle Beratung
- Hochwertige Produkte
- Kostenloser und schneller Versand



- TOP Bewertungen
- Exzelerter Kundenservice
- Über 20 Jahre Erfahrung



E-Mail: info@unidomo.de | Tel.: 04621 - 30 60 89 0 | www.unidomo.de



Sicherheitshinweise

-  Bei der Montage müssen zur Vermeidung von Quetsch- und Schnittverletzungen Handschuhe getragen werden.
-  Bei 5 Liter Geräten darf die Auslaufleistung am Mischer 5 l/min nicht übersteigen. Gegebenenfalls Wasserzufuhr am Eckventil regulieren.

Montagehinweise

- Vor der Montage muss das Produkt auf Transportschäden untersucht werden. Nach dem Einbau werden keine Transport- oder Oberflächenschäden anerkannt.
- Die Leitungen und die Armatur müssen nach den gültigen Normen montiert, gespült und geprüft werden.
- Die in den Ländern jeweils gültigen Installationsrichtlinien sind einzuhalten.
- Kunststoffschlauch, falls notwendig, gemäß Tabelle kürzen und in das kurze, blau markierte Rohr bis zum Bund einschieben.

Technische Daten

Betriebsdruck:	max. 1 MPa
Empfohlener Betriebsdruck:	0,1 - 0,5 MPa
Prüfdruck:	1,6 MPa
(1 MPa = 10 bar = 147 PSI)	
Heißwassertemperatur:	max. 80 °C
Empfohlene Heißwassertemperatur:	65 °C
Thermische Desinfektion:	max. 70 °C / 4 min
Durchflussleistung:	max. 5 l/min

Das Produkt ist ausschließlich für Trinkwasser konzipiert!

Tabelle über die zu verwendenden Drosselschlauchlängen

Höchstmöglicher Wasserdruck am Verwendungsort in MPa	Geräteinhalt	
	8, 10 und 15 Liter	bis 5 Liter
0,1 - 0,15	ohne Drosselschlauch	Drosselschlauch auf 90 mm gekürzt
0,2 - 0,3	Drosselschlauch auf 90 mm gekürzt	Drosselschlauch unverändert
0,4 - 0,7	Drosselschlauch unverändert	

Durchflussmenge am Eckventil einregulieren

Bei einem Ruhedruck über 0,5 MPa muss ein Druckminderer eingebaut werden.

Symbolbeschreibung

Kein essigsäurehaltiges Silikon verwenden!



Reinigung

siehe beiliegende Broschüre.

Maße (siehe Seite 12)



Bedienung (siehe Seite 14)

Beim Aufheizen des Wasserspeichers tritt am Auslauf Tropfwasser aus.



Serviceile (siehe Seite 13)

Wird der Strahlformer gewechselt, muss ein für diese Armatur zugelassener Strahlformer verwendet werden.

Sonderzubehör (nicht im Lieferumfang enthalten)

Montageschlüssel #58085000



Installationskit

Prüfzeichen (siehe Seite 14)



Störung

Ursache

Abhilfe



Wenig Wasser	- Strahlformer verkalkt, verschmutzt	- Strahlformer reinigen, ggf. austauschen
Armatur schwergängig	- Kartusche defekt, verkalkt	- Kartusche austauschen
Armatur tropft ständig bei ausgeschaltetem Wasserbereiter	- Kartusche defekt	- Kartusche austauschen



Montage siehe Seite 10



Consignes de sécurité

-  Lors du montage, porter des gants de protection pour éviter toute blessure par écrasement ou coupure.
-  Sur les chauffe-eau à contenance de 5 litres le débit ne doit pas dépasser 5l/min, dans ce cas là, réduire le débit avec le robinet d'arrêt et d'équerre.

Instructions pour le montage

- Avant son montage, s'assurer que le produit n'a subi aucun dommage pendant le transport. Après le montage, tout dommage de transport ou de surface ne pourra pas être reconnu.
- Les conduites et la robinetterie doivent être montés, rincés et contrôlés selon les normes en vigueur.
- Les directives d'installation en vigueur dans le pays concerné doivent être respectées.
- Raccourcir éventuellement selon les indications du tableau ci-dessous le tube platique et l'enfoncer jusqu'à la butée dans la tubulure courte avec repère bleu.

Informations techniques

Pression de service autorisée:	max. 1 MPa
Pression de service conseillée:	0,1 - 0,5 MPa
Pression maximum de contrôle:	1,6 MPa
(1 MPa = 10 bar = 147 PSI)	
Température d'eau chaude:	max. 80 °C
Température recommandée:	65 °C
Désinfection thermique:	max. 70 °C / 4 min
Débit:	max. 5 l/min

Le produit est exclusivement conçu pour de l'eau potable!

Description du symbole



Ne pas utiliser de silicone contenant de l'acide acétique!



Nettoyage

voir la brochure ci-jointe.



Dimensions (voir pages 12)



Instructions de service (voir pages 14)

Le mitigeur goutte lorsque le chauffe-eau monte en température.



Pièces détachées (voir pages 13)

Si l'on change le aérateur, il faudra utiliser un aérateur normalisé pour cette robinetterie.



Accessoires en option (ne fait pas partie de la fourniture)

clé de montage #58085000



Mastic d'installation



Classification acoustique et débit (voir pages 14)

Tableau relatif aux longueurs de tube d'étranglement à utiliser

Pression d'eau maxi possible en MPa sur le lieu d'utilisation	Contenu de l'appareil	
	8, 10 et 15 litres	jusqu'à 5 litres
0,1 - 0,15	sans tube d'étranglement	Tube d'étranglement raccourci à 90 mm
0,2 - 0,3	Tube d'étranglement raccourci à 90 mm	Tube d'étranglement pas modifié
0,4 - 0,7	Tube d'étranglement pas modifié	

Régler le débit au niveau du robinet d'équerre
Incorporer un réducteur de pression si la pression est supérieure à 0,5 MPa.



Dysfonctionnement	Origine	Solution
Pas assez d'eau	- Mousseur entartré ou encrassé	- Nettoyer le mousseur ou le changer éventuellement
Dureté de fonctionnement	- Cartouche défectueuse, entartrée	- Changer la cartouche
Le mitigeur goutte sans arrêt avec un chauffe-eau hors-service	- Cartouche défectueuse	- Changer la cartouche



Montage voir pages 10



Safety Notes

-  Gloves should be worn during installation to prevent crushing and cutting injuries.
-  With water heaters of 5 liters the flow rate at the mixer should not exceed 5 l/min. In this case the flow rate must be reduced at the isolation valve.

Installation Instructions

- Prior to installation, inspect the product for transport damages. After it has been installed, no transport or surface damage will be honoured.
- The pipes and the fixture must be installed, flushed and tested as per the applicable standards.
- The plumbing codes applicable in the respective countries must be observed.
- If necessary shorten plastic hose according to the table and insert it up to the collar into the shorter blue marked copper pipe.

Technical Data

Operating pressure:	max. 1 MPa
Recommended operating pressure:	0,1 - 0,5 MPa
Test pressure:	1,6 MPa
(1 MPa = 10 bar = 147 PSI)	
Hot water temperature:	max. 80 °C
Recommended hot water temp.:	65 °C
Thermal disinfection:	max. 70 °C / 4 min
Rate of flow:	max. 5 l/min

The product is exclusively designed for drinking water!

Symbol description

Do not use silicone containing acetic acid!



Cleaning

see enclosed brochure.



Dimensions (see page 12)



Operation (see page 14)

When the storage tank is being heated, the spout will drip.



Spare parts (see page 13)

When changing the spray former, it is imperative to use one made for this type of mixer.

Special accessories (order as an extra)

special tool #58085000



Installation putty



Test certificate (see page 14)

Table for the throttle hose lengths to be used

Highest possible water pressure at user's site in Mpa	Device content	
	8, 10 and 15 liters	up to 5 liters
0,1 - 0,15	without throttle hose	Throttle hose shortened to 90 mm
0,2 - 0,3	Throttle hose shortened to 90 mm	Throttle hose unchanged
0,4 - 0,7	Throttle hose unchanged	

Adjust flow volume at corner valve

If the water pressure is greater than 0,5 MPa, fit a pressure reducing valve.



Fault	Cause	Remedy
Insufficient water	- Spray former calcified, dirty	- Clean spray former, exchanging if necessary
Mixer stiff	- Cartridge defective, calcified	- Exchange cartridge
Mixer dripping constantly with water heater switched off	- Cartridge defective	- Exchange cartridge



Assembly see page 10



Indicazioni sulla sicurezza

-  Durante il montaggio, per evitare ferite da schiacciamento e da taglio bisogna indossare guanti protettivi.
-  Nel caso di apparecchi da 5 litri l'erogazione del miscelatore non deve superare i 5 l/min. Eventualmente strozzare l'alimentazione d'acqua del rubinetto a squadra.

Istruzioni per il montaggio

- Prima del montaggio è necessario controllare che non ci siano stati danni durante il trasporto. Una volta eseguito il montaggio, non verranno riconosciuti eventuali danni di trasporto o delle superfici.
- Montare, lavare e controllare tubature e rubinetteria rispettando le norme correnti.
- Vanno rispettate le direttive di installazione nazionali vigenti nel rispettivo paese.
- Se necessario, tagliare il flessibile in plastica secondo la tabella e introdurlo sino allo spallamento nel tubo corto contrassegnato in blu.

Dati tecnici

Pressione d'uso:	max. 1 MPa
Pressione d'uso consigliata:	0,1 - 0,5 MPa
Pressione di prova:	1,6 MPa
(1 MPa = 10 bar = 147 PSI)	
Temperatura dell'acqua calda:	max. 80 °C
Temp. dell'acqua calda consigliata:	65 °C
Disinfezione termica:	max. 70 °C / 4 min
Portata di erogazione:	max. 5 l/min

Tabella delle lunghezze dei tubi di strozzamento applicabili

Massima pressione d'acqua sul posto espressa in MPa	Contenuto dell'apparecchio	
	8, 10 e 15 litri	fino a 5 litri
0,1 - 0,15	senza tubo di strozzamento	Tubo di strozzamento ridotto a 90 mm
0,2 - 0,3	Tubo di strozzamento ridotto a 90 mm	Tubo di strozzamento non modificato
0,4 - 0,7	Tubo di strozzamento non modificato	

In caso di una pressione di flusso superiore a 0,2 MPa, si deve installare un riduttore sul tubo principale.

Problema	Possibile causa	Rimedio
Scarsità d'acqua	- diffusore del getto difettoso, pieno di calcare	- Pulire oppure sostituire il diffusore del getto
Miscelatore duro	- Cartuccia difettosa	- Sostituire la cartuccia
Il miscelatore perde acqua di continuo con la caldaia spenta	- Cartuccia difettosa	- Sostituire la cartuccia

Il prodotto è concepito esclusivamente per acqua potabile!

Descrizione simbolo



Non utilizzare silicone contenente acido acetico!



Pulitura

vedi il prospetto accluso.



Ingombri (vedi pagg. 12)



Procedura (vedi pagg. 14)

Durante il riscaldamento del serbatoio d'acqua all'uscita si ha uno stillicidio.



Parti di ricambio (vedi pagg. 13)

Se si cambia il rompigitto, per questo rubinetto deve venir usato un rompigitto idoneo.



Accessori speciali (non contenuto nel volume di fornitura)

chiave per montaggio #58085000



Mastice d'installazione



Segno di verifica (vedi pagg. 14)



Montaggio vedi pagg. 10



Indicaciones de seguridad

- ⚠ Durante el montaje deben utilizarse guantes para evitar heridas por aplastamiento o corte.
- ⚠ En caso de utilizar un calentador de 5 litros de capacidad el caudal de agua que pasa por el mezclador, no debe superar 5 l/min. En caso necesario, disminuir la entrada del agua por medio de la llave de escuadra.

Indicaciones para el montaje

- Antes del montaje se debe examinarse el producto contra daños de transporte. Después de la instalación so se reconoce ningún daño de transporte o de superficie.
- Los conductos y la grifería deben montarse, lavarse y comprobarse según las normas vigentes.
- Es obligatorio el cumplimiento de las directrices de instalación vigentes en el país respectivo.
- En caso necesario, cortar el tubo plástico como indicado en el esquema e introducir el mismo hasta el collarín en el caño corto marcado azul.

Datos técnicos

Presión en servicio:	max. 1 MPa
Presión recomendada en servicio:	0,1 - 0,5 MPa
Presión de prueba:	1,6 MPa
(1 MPa = 10 bar = 147 PSI)	
Temperatura del agua caliente:	max. 80 °C
Temp. recomendada del agua caliente:	65 °C
Desinfección térmica:	max. 70 °C / 4 min
Caudal máximo:	max. 5 l/min

Tabla para el largo de la manguera de estrangulación aplicable

Presión de agua más alta posible en el lugar de aplicación en Mpa	Contenido del equipo	
	8,10 y 15 litros	hasta 5 litros
0,1 - 0,15	sin manguera de estrangulación	Manguera de estrangulación reducida a 90 mm
0,2 - 0,3	Manguera de estrangulación reducida a 90 mm	Manguera de estrangulación no modificada
0,4 - 0,7	Manguera de estrangulación no modificada	

En condiciones de presión de reposo superior a 0,5 MPa, es imprescindible montar un reductor de presión.

Problema	Causa	Solución
Sale poca agua	- Formador de chorro ensuciado, calcificado	- Limpiar o cambiar el formador de chorro
Manecilla va dura	- cartucho dañado	- cambiar el cartucho
Grifo pierde continuamente agua con calientaguas apagado	- cartucho dañado	- cambiar el cartucho

El producto ha sido concebido exclusivamente para agua potable.

Descripción de símbolos



No utilizar silicona que contiene ácido acético!



Limpiar

ver el folleto adjunto.



Dimensiones (ver página 12)



Manejo (ver página 14)

Al calentar el depósito de agua suelen desbordarse de la salida siempre unas gotas de agua.



Repuestos (ver página 13)

En caso de cambiar el aireador, hay que utilizar un aireador adecuado para este tipo de grifería.



Opcional (no incluido en el suministro)

Llave de montaje #58085000



Masilla





Marca de verificación (ver página 14)



Montaje ver página 10



Veiligheidsinstructies

-  Bij de montage moeten ter voorkoming van knel- en snijwonden handschoenen worden gedragen.
-  Bij toestellen van 5 liter mag de uitloopcapaciteit aan de mengkraan niet hoger zijn dan 5 l/min. Indien nodig moet de watertoevoer aan de hoekstopkraan geregeld worden.

Montage-instructies

- Vóór de montage moet het product gecontroleerd worden op transportschade. Na de inbouw wordt geen transport- of oppervlakteschade meer aanvaard.
- De leidingen en armaturen moeten gemonteerd, gespoeld en gecontroleerd worden volgens de geldige normen.
- De in de overeenkomstige landen geldende installatie-richtlijnen moeten nageleefd worden.
- Kunststofslang, indien nodig, volgens tabel verkorten en tot aan de kraag in de korte, blauw gemarkeerde buis schuiven.

Technische gegevens

Werkdruk: max.	max. 1 MPa
Aanbevolen werkdruk:	0,1 - 0,5 MPa
Getest bij:	1,6 MPa
(1 MPa = 10 bar = 147 PSI)	
Temperatuur warm water:	max. 80 °C
Aanbevolen warm water temp.:	65 °C
Thermische desinfectie:	max. 70 °C / 4 min
Doorstroomcapaciteit:	max. 5 l/min

Het product is uitsluitend ontworpen voor drinkwater!

Symboolbeschrijving



Gebruik geen zuurhoudende silicone!



Reinigen

zie bijgevoegde brochure.



Maten (zie blz. 12)



Bediening (zie blz. 14)

Bij het opwarmen van het waterreservoir ontsnapt aan de uitloop drupwater.



Service onderdelen (zie blz. 13)

Indien de straalvormer vervangen wordt, moet een straalvormer gebruikt worden die is toegelaten voor deze armatuur.



Toebehoren (behoort niet tot het leveringspakket)

montagesleutel #58085000



Kit



Keurmerk (zie blz. 14)

Tabel van de te gebruiken reduceerslanglengten

Maximale waterdruk op de gebruiksplaats in MPa	Inhoud van het toestel	
	8, 10 en 15 liter	tot 5 liter
0,1 - 0,15	zonder reduceerslang	Reduceerslang verkort tot 90 mm
0,2 - 0,3	Reduceerslang verkort tot 90 mm	Reduceerslang onveranderd
0,4 - 0,7	Reduceerslang onveranderd	Debiet instellen aan het hoekventiel

Bij een statische druk van meer dan 0,5 MPa moet een drukregelaar ingebouwd worden.

Storing

Oorzaak

Oplossing



Weinig water	- Straalopeningens verkalkt, vuil	- Straalopeningens reinigen, indien nodig vervangen
Bediening zwaar	- Kardoes defect of verkalkt	- Kardoes uitwisselen
Armatuur drupt altijd bij een uitgeschakelde boiler	- Kardoes defect	- Kardoes uitwisselen



Montage zie blz. 10



Sikkerhedsanvisninger

-  Ved monteringen skal der bruges handsker for at undgå kvæstelser og snitsår.
-  Ved 5 litres beholdere må udløbsydelsen ved håndvaskarmaturet ikke overstige 5 liter/min. I modsat fald drosles vandet ved vandtilførslen ved hjørneventilen.

Monteringsanvisninger

- Før monteringen skal produktet kontrolleres for transportkader. Efter monteringen godkendes transportkader eller skader på overfladen ikke længere.
- Ledningerne og armaturerne skal monteres, skylles og kontrolleres iht. de gældende standarder.
- Installationsbestemmelserne, der gælder i det enkelte land, skal overholdes.
- Plastslange afkortes i henhold til tabellen og skubbes ind til bundet i det blåfarvede rør.

Tekniske data

Driftstryk:	max. 1 MPa
Anbefalet driftstryk:	0,1 - 0,5 MPa
Prøvetryk:	1,6 MPa
(1 MPa = 10 bar = 147 PSI)	
Varmtvandstemperatur:	max. 80 °C
Anbefalet varmtvandstemperatur:	65 °C
Termisk desinfektion:	max. 70 °C / 4 min
Gennemstrømningskapacitet:	max. 5 l/min

Produktet er udelukkende beregnet til drikkevand!

Symbolbeskrivelse

Der må ikke benyttes eddikesyreholdig silikone!



Rengøring

se venligst den vedlagte brochure.



Målene (se s. 12)



Brugsanvisning (se s. 14)

Ved opvarmning af varmtvandsbeholderen forekommer dryp fra udløbstuden.



Reserve dele (se s. 13)

Ved skift af stråleformeren, skal der anvendes en stråleformer, som er godkendt til dette armatur

Specialtilbehør (ikke med i leveringsomfang)

Monteringsnøgle #58085000



Kitt



Godkendelse (se s. 14)

Tabel over de drosselslangelængder, som skal bruges

Højest muligt vandtryk på brugsstedet i MPa	Enhedens indhold	
	8, 10 og 15 liter	op til 5 liter
0,1 - 0,15	uden drosselslange	Drosselslange afkortet til 90 mm
0,2 - 0,3	Drosselslange afkortet til 90 mm	Drosselslange uforandret
0,4 - 0,7	Drosselslange uforandret	

Juster gennemstrømningsmængden på hjørneventilen

Ved et rørtryk på mere end 0,5 MPa, skal trykket reduceres.



Fejl	Årsag	Hjælp
For lidt vand	- Stråleformer forkalket, tilsmudset	- Stråleformer renses, skiftes i givet fald ud
Grebet går trægt	- Kartusche defekt, tilkalket	- Udskift kartusche
Armatur drypper hele tiden ved slukket vandvarmer	- Defekt kartusche	- Udskift kartusche



Montering se s. 10



Указания по технике безопасности

-  Во время монтажа следует надеть перчатки во избежание прищемления и порезов.
-  Для 5-литровых приборов производительность выхода на смесителе не должна превышать 5 л/мин. При необходимости отрегулируйте подачу воды на угловом вентиле

Указания по монтажу

- Перед монтажом следует проверить изделие на предмет повреждений при перевозке. После монтажа претензии о возмещении ущерба за повреждения при перевозке или повреждения поверхностей не принимаются.
- Трубы и арматура должны быть установлены, промыты и проверены в соответствии с действующими нормами.
- Необходимо соблюдать требования по монтажу, действующие в соответствующих странах.
- Пластмассовый шланг, если необходимо, укоротите, согласно таблице и вставьте в короткую трубу с синей маркировкой до буртика.

Технические данные

Рабочее давление: не более. 1 МПа
 Рекомендуемое рабочее давление: 0,1 - 0,5 МПа
 Давление: 1,6 МПа
 (1 МПа = 10 bar = 147 PSI)
 Температура горячей воды: не более. 80 °С
 Рекомендуемая темп. гор. воды: 65 °С
 Термическая дезинфекция: не более. 70 °С / 4 мин

Пропускная способность: не более. 5 л/мин

Изделие предназначено исключительно для питьевой воды!

Описание символов



Не применяйте силикон, содержащий уксусную кислоту.



Очистка

см прилагаемая брошюра



Размеры (см. стр. 12)



Эксплуатация (см. стр. 14)

При подогреве водяного резервуара из выхода капает вода.



Комплект (см. стр. 13)

При замене формирователя струи необходимо использовать формирователь струи, предназначенный для этой арматуры.

Специальные принадлежности (не включено в объем поставки!)

Монтажный ключ #58085000



Монтаж подводки



Знак технического контроля (см. стр. 14)

Таблица длин используемых шлангов дросселя

Максимальное давление воды на участке применения в МПа	Емкость устройств	
	8, 10 и 15 литров	до 5 литров
0,1 - 0,15	Без шланга дросселя	Шланг дросселя укороченный, длина 90 мм
0,2 - 0,3	Шланг дросселя укороченный, длина 90 мм	Шланг дросселя неизменной длины
0,4 - 0,7	Шланг дросселя неизменной длины	

При статическом давлении более 0,5 МПа необходимо устанавливать редукционный клапан.

Неисправность	Причина	Устранение неисправности
недостаточный давление (если устан напор воды)	- Формирователь струи имеет известковые отложения/загрязнен	- Очистите формирователь струи, по мере необходимости замените
Арматура работает с усилием	- Картридж неисправен, засорение накипью	- Замените картридж
Из арматуры при подключенном водонагревателе постоянно капает вода	- Картридж неисправен	- Замените картридж



Монтаж см. стр. 10

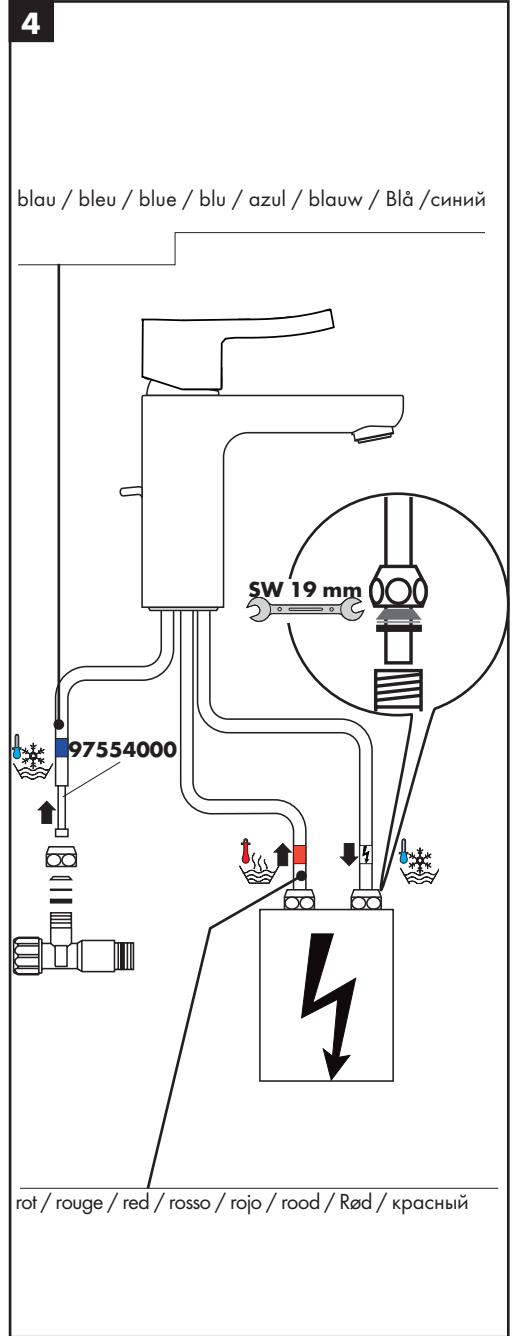
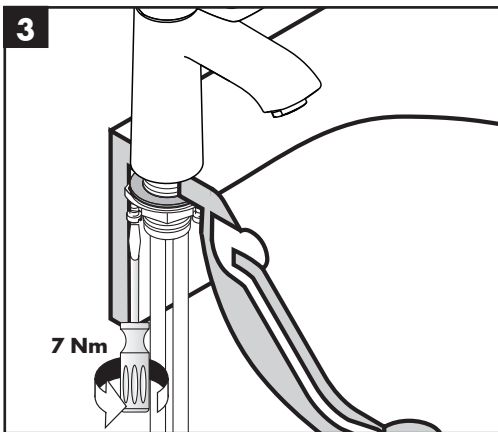
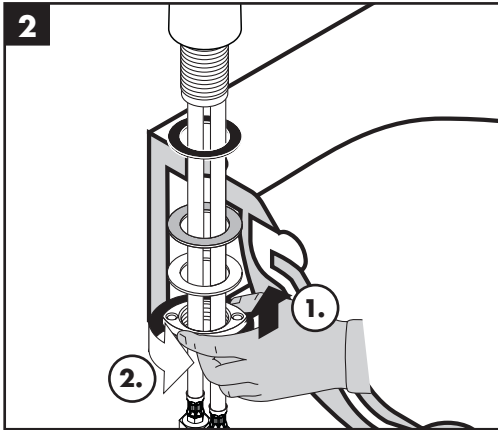
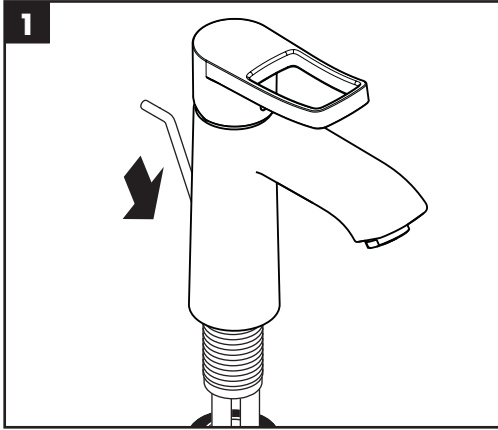

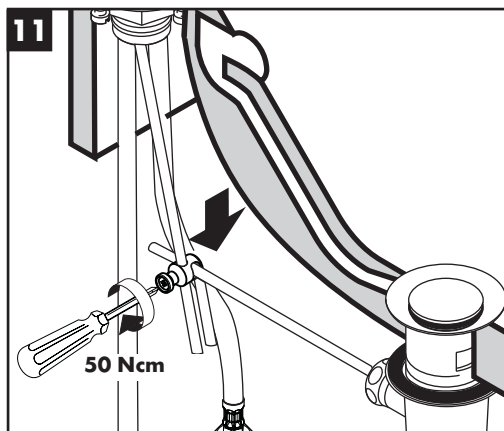
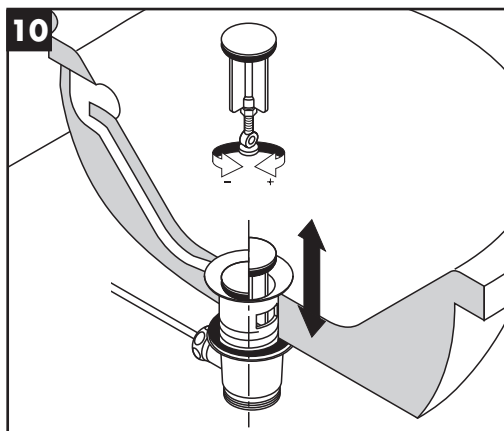
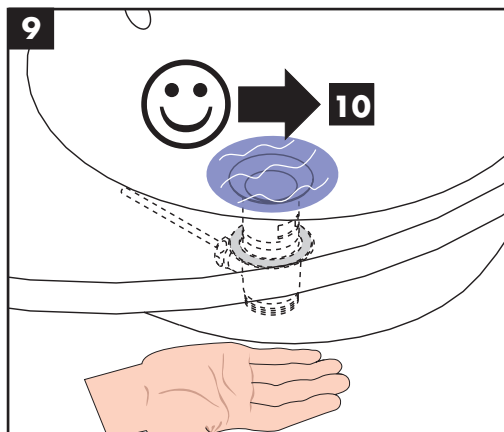
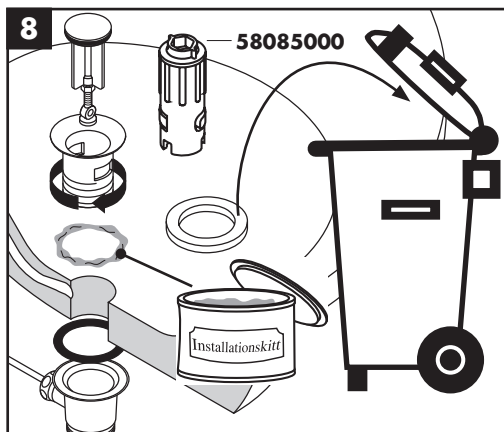
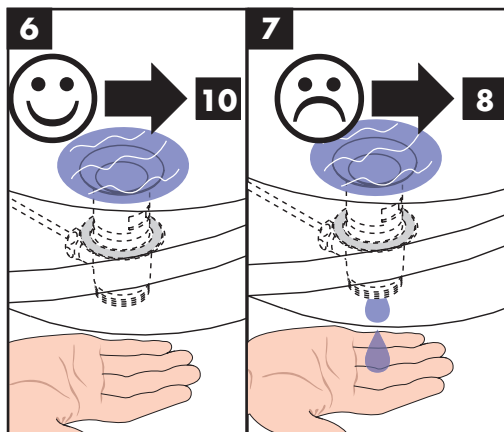
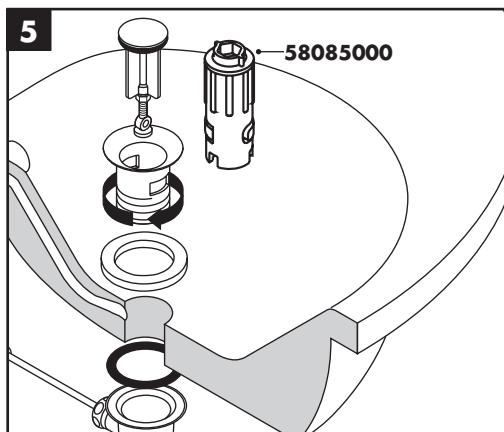



Mediano (2012)

14512000

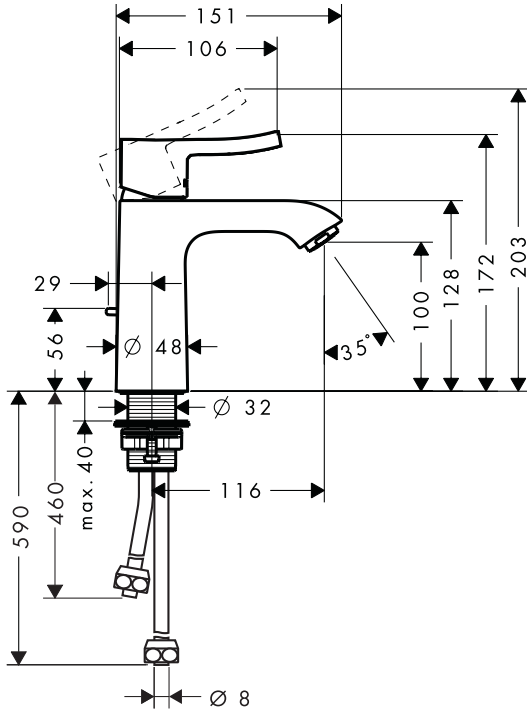

94139000

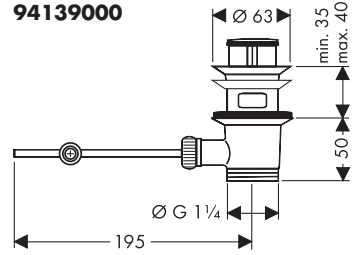

94139007

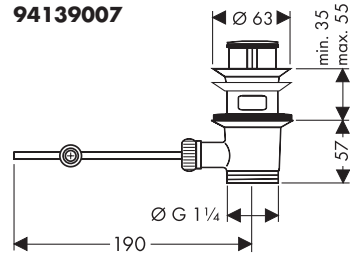



Mediano (2012)
14512000

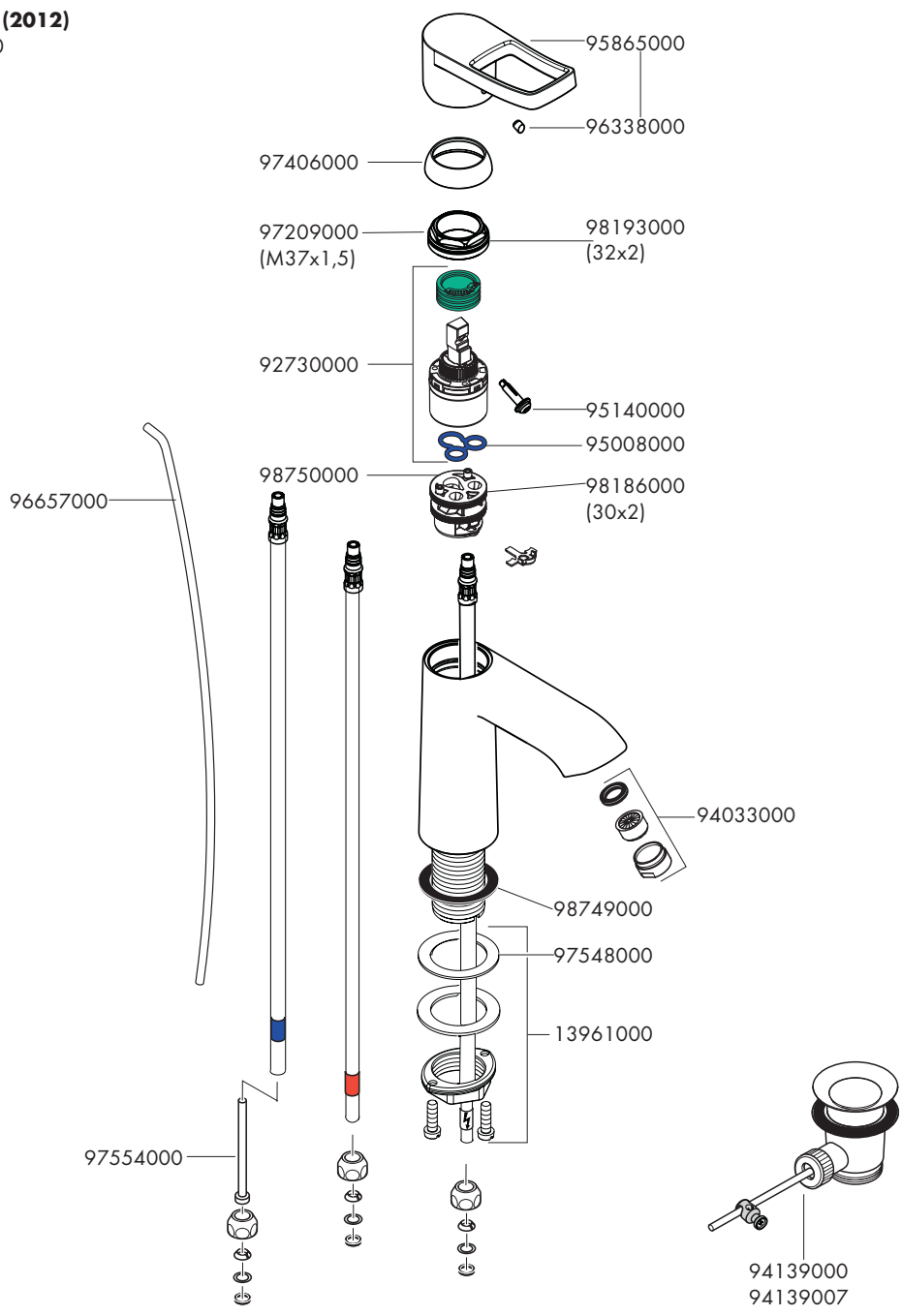

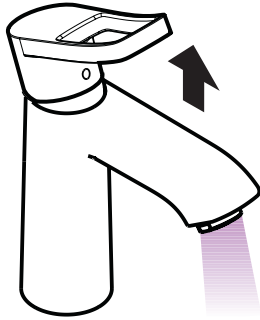

öffnen / ouvert / open / aperto / abierto / open / åbne /
открыть

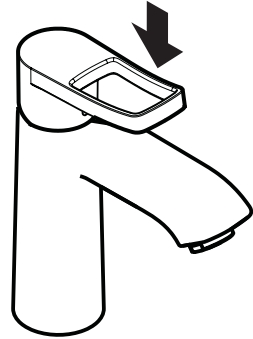

schließen / fermé / close / chiudere / cerrar / sluiten /
lukke / закрыть

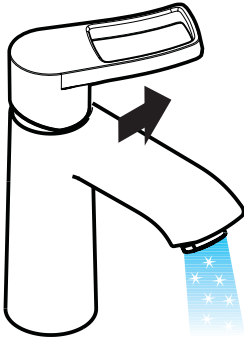

kalt / froid / cold / freddo / frío / koud / koldt /
холодная

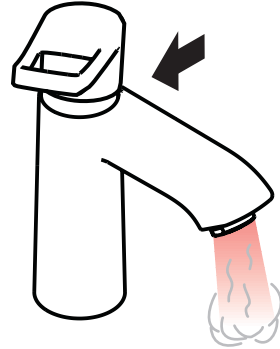

warm / chaud / hot / caldo / caliente / warm / varmt /
горячая



P-IX

DVGW

SVGW

WRAS

KIWA

NF

ACS

ETA

14512000

P-IX 19986/10





