

- DE** Gebrauchsanleitung / Montageanleitung  
**FR** Mode d'emploi / Instructions de montage  
**EN** Instructions for use / assembly instructions  
**IT** Istruzioni per l'uso / Istruzioni per Installazione  
**ES** Modo de empleo / Instrucciones de montaje  
**NL** Gebruiksaanwijzing / Handleiding  
**DK** Brugsanvisning / Monteringsvejledning  
**PT** Instruções para uso / Manual de Instalação  
**PL** Instrukcja obsługi / Instrukcja montażu  
**CS** Návod k použití / Montážní návod  
**SK** Návod na použitie / Montážny návod  
**ZH** 用户手册 / 组装说明  
**RU** Руководство пользователя / Инструкция по монтажу  
**HU** Használati útmutató / Szerelési útmutató  
**FI** Käyttöohje / Asennusohje  
**SV** Bruksanvisning / Monteringsanvisning  
**LT** Vartotojo instrukcija / Montavimo instrukcijos  
**HR** Upute za uporabu / Uputstva za instalaciju  
**TR** Kullanım kılavuzu / Montaj kılavuzu  
**RO** Manual de utilizare / Instrucțiuni de montare  
**EL** Οδηγίες χρήσης / Οδηγία συναρμολόγησης  
**SL** Navodilo za uporabo / Navodila za montažo  
**ET** Kasutusjuhend / Paigaldusjuhend  
**LV** Lietošanas pamācība / Montāžas instrukcija  
**SR** Uputstvo za upotrebu / Uputstvo za montažu  
**NO** Bruksanvisning / Montasjeveiledning  
**BG** Инструкция за употреба / Ръководство за монтаж  
**SQ** Udhëzuesi i përdorimit / Udhëzime rreth montimit  
**AR** دليل الاستخدام / تعليمات التجميع

- 2  
3  
4  
5  
6  
7  
8  
9  
10  
11  
12  
13  
14  
15  
16  
17  
18  
19  
20  
21  
22  
23  
24  
25  
26  
27  
28  
29  
30

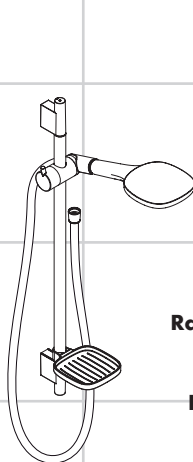

**Raindance Select S 150 /  
Unica'S Puro Set**  
27802XXX / 27803XXX  
**Raindance Select 150  
Combi**  
27036XXX / 27037XXX

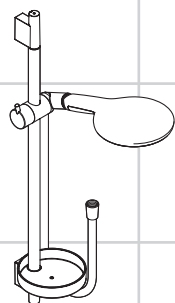

**Raindance Select S 120  
Unica Set**  
26630XXX / 26631XXX

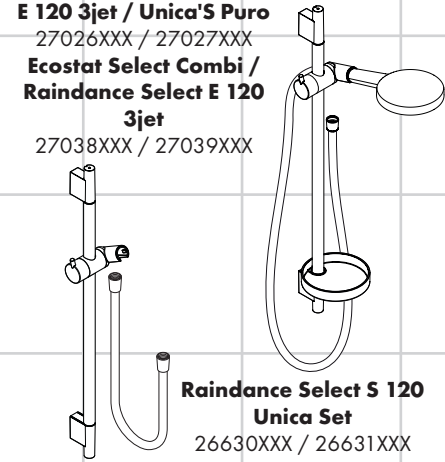

**Unica'S Puro**  
28631XXX / 28632000



**Ihr Online-Fachhändler für:**

**hansgrohe**

- Kostenlose und individuelle Beratung
- Hochwertige Produkte
- Kostenloser und schneller Versand

- TOP Bewertungen
- Exzelerter Kundenservice
- Über 20 Jahre Erfahrung



**E-Mail: [info@unidomo.de](mailto:info@unidomo.de) | Tel.: 04621 - 30 60 89 0 | [www.unidomo.de](http://www.unidomo.de)**



## Sicherheitshinweise

- ⚠ Bei der Montage müssen zur Vermeidung von Quetsch- und Schnittverletzungen Handschuhe getragen werden.
- ⚠ Das Produkt darf nur zu Bade-, Hygiene- und Körperreinigungszwecken eingesetzt werden.
- ⚠ Das Produkt darf nicht als Haltegriff benutzt werden. Es muss ein separater Haltegriff montiert werden.
- ⚠ Brausenschläuche sind nur zum Anschluss von Brausen an Armaturen geeignet. Eine Absperrung nach dem Schlauch in Fließrichtung ist unzulässig!

## Montagehinweise

- Vor der Montage muss das Produkt auf Transportschäden untersucht werden. Nach dem Einbau werden keine Transport- oder Oberflächenschäden anerkannt.
- Die Leitungen und die Armatur müssen nach den gültigen Normen montiert, gespült und geprüft werden.
- Die in den Ländern jeweils gültigen Installationsrichtlinien sind einzuhalten.
- Thermostat: Bedienung / Montage siehe beiliegende Broschüre.
- Bei der Montage des Produktes durch qualifiziertes Fachpersonal ist darauf zu achten, dass die Befestigungsfläche im gesamten Bereich der Befestigungsplan ist (keine vorstehenden Fugen oder Fliesenversatz), der Wandaufbau für eine Montage des Produktes geeignet ist und keine Schwachstellen aufweist.
- Optimale Funktion nur in Verbindung mit Hansgrohe Handbrausen und Hansgrohe Brausenschläuchen garantiert.

## Symbolerklärung



Kein essigsäurehaltiges Silikon verwenden!



**Maße** (siehe Seite 34)



**Bedienung** (siehe Seite 31)



**Reinigung**

siehe beiliegende Broschüre



**Serviceteile** (siehe Seite 38)

**XXX = Farbcodierung**

000 = chrom

820 = brushed nickel

**Sonderzubehör** (nicht im Lieferumfang enthalten)



Fliesenausgleichsscheibe #97450XXX  
(siehe Seite 38)



**Prüfzeichen** (siehe Seite 40)



**Montage siehe Seite 32**



## Consignes de sécurité

- ⚠ Lors du montage, porter des gants de protection pour éviter toute blessure par écrasement ou coupure.
- ⚠ Le produit ne doit servir qu'à se laver et à assurer l'hygiène corporelle.
- ⚠ Le produit ne doit pas servir de poignée. Monter pour cela une poignée séparée.
- ⚠ Les flexibles de douche ne doivent être utilisés que pour le raccordement d'une douche à main à un robinet. Le montage d'un système d'arrêt après le flexible, en direction du courant d'eau est strictement interdit.

## Instructions pour le montage

- Avant son montage, s'assurer que le produit n'a subi aucun dommage pendant le transport. Après le montage, tout dommage de transport ou de surface ne pourra pas être reconnu.
- Les conduites et la robinetterie doivent être montés, rincés et contrôlés selon les normes en vigueur.
- Les directives d'installation en vigueur dans le pays concerné doivent être respectées.
- Mitigeur thermostatique: Instructions de service / Montage voir la brochure ci-jointe.
- Lors du montage de ce produit par du personnel qualifié, veiller à ce que la surface de fixation soit bien plane dans toute la zone de fixation (pas de dépassement de joints ou de déport de carreaux), à ce que le mur se prête au montage du produit et ne présente aucun point fragile.
- Un fonctionnement optimal est seulement garanti en combinaison avec des douches à main et des flexibles Hansgrohe.

## Description du symbole



Ne pas utiliser de silicone contenant de l'acide acétique!



**Dimensions** (voir pages 34)



**Instructions de service**  
(voir pages 31)



**Nettoyage**

voir la brochure ci-jointe



**Pièces détachées** (voir pages 38)

**XXX = Couleurs**

000 = chromé

820 = brushed nickel

**Accessoires en option** (ne fait pas partie de la fourniture)

cale de compensation #97450XXX  
(voir pages 38)



**Classification acoustique et débit** (voir pages 40)



**Montage voir pages 32**



## Safety Notes

- ⚠️ Gloves should be worn during installation to prevent crushing and cutting injuries.
- ⚠️ The product may only be used for bathing, hygienic and body cleaning purposes.
- ⚠️ The product may not be used as a holding handle. A separate handle must be installed.
- ⚠️ Shower hoses are only suitable for a connection from the shower to the fitting. Never fit a shut-off device between the fitting and the hose.

## Installation Instructions

- Prior to installation, inspect the product for transport damages. After it has been installed, no transport or surface damage will be honoured.
- The pipes and the fixture must be installed, flushed and tested as per the applicable standards.
- The plumbing codes applicable in the respective countries must be observed.
- Thermostatic mixer: Operation / Assembly see enclosed brochure.
- During installation of the product by qualified trained personnel, make sure that the entire fastening surface is even and smooth (no protruding seams or tile offset), that the finish of the wall is suitable to apply the product and has no weak points.
- Optimal functioning is only guaranteed with the combination of Hansgrohe hand showers and Hansgrohe shower hoses.

## Symbol description



Do not use silicone containing acetic acid!



**Dimensions** (see page 34)



**Operation** (see page 31)



**Cleaning**

see enclosed brochure



**Spare parts** (see page 38)

**XXX = Colors**

000 = chrome plated

820 = brushed nickel

**Special accessories** (order as an extra)

tile-matching-disk #97450XXX

(see page 38)



**Test certificate** (see page 40)



**Assembly see page 32**



## **Indicazioni sulla sicurezza**

- ⚠ Durante il montaggio, per evitare ferite da schiacciamento e da taglio bisogna indossare guanti protettivi.
- ⚠ Il prodotto deve essere utilizzato esclusivamente per fare il bagno e per l'igiene del corpo.
- ⚠ Il prodotto non deve essere utilizzato come maniglia, questa deve essere montata separatamente.
- ⚠ I flessibili devono essere inseriti solo tra l'uscita dell'acqua e la doccetta. Non deve essere introdotta alcuna prolunga tra il flessibile e l'uscita dell'acqua.

## **Istruzioni per il montaggio**

- Prima del montaggio è necessario controllare che non ci siano stati danni durante il trasporto. Una volta eseguito il montaggio, non verranno riconosciuti eventuali danni di trasporto o delle superfici.
- Montare, lavare e controllare tubature e rubinetteria rispettando le norme correnti.
- Vanno rispettate le direttive di installazione nazionali vigenti nel rispettivo paese.
- Termostatico: Procedura / Montaggio vedi il prospetto accluso.
- Per il montaggio del prodotto da personale specializzato qualificato bisogna fare attenzione, che la superficie di fissaggio, in tutto il campo di fissaggio, sia piana (nessuna giunzione sporgente o sfalsamento di piastrella), la costruzione della parete sia adatta al montaggio del prodotto e che non presenti alcun punto debole.
- Funzionalità ottimale solamente in combinazione con doccette e flessibili Hansgrohe.

## **Descrizione simbolo**



Non utilizzare silicone contenente acido acetico!



**Ingombri** (vedi pagg. 34)



**Procedura** (vedi pagg. 31)



**Pulitura**

vedi il prospetto accluso



**Parti di ricambio** (vedi pagg. 38)

**XXX = Trattamento**

000 = cromato

820 = brushed nickel

**Accessori speciali** (non contenuto nel volume di fornitura)

distanziali da piastrella #97450XXX  
(vedi pagg. 38)



**Segno di verifica** (vedi pagg. 40)



**Montaggio vedi pagg. 32**



## Indicaciones de seguridad

- ⚠ Durante el montaje deben utilizarse guantes para evitar heridas por aplastamiento o corte.
- ⚠ El producto solo debe ser utilizado para fines de baño, higiene y limpieza corporal.
- ⚠ El producto no debe ser utilizado como un elemento de sujeción. Debe montarse un elemento de sujeción separado.
- ⚠ Los flexos deben usarse exclusivamente para la conexión entre grifería y teleducha. Cualquier función de cierre tras el flexo y en la dirección del flujo del agua no está permitida.

## Indicaciones para el montaje

- Antes del montaje se debe examinarse el producto contra daños de transporte. Después de la instalación no se reconoce ningún daño de transporte o de superficie.
- Los conductos y la grifería deben montarse, lavarse y comprobarse según las normas vigentes.
- Es obligatorio el cumplimiento de las directrices de instalación vigentes en el país respectivo.
- Termostato: Manejo / Montaje ver el folleto adjunto.
- Durante el montaje del producto, mediante personal especializado, se debe asegurar de que la superficie de sujeción en todo el área de la fijación sea plana (sin fugas o azulejos que sobresalgan), que la estructura del muro sea adecuada para el montaje del producto y que no presente puntos débiles.
- Sólo se garantiza una función óptima en combinación con teleduchas y flexos de Hansgrohe.

## Descripción de símbolos



No utilizar silicona que contiene ácido acético!



**Dimensiones** (ver página 34)



**Manejo** (ver página 31)



**Limpiar**

ver el folleto adjunto



**Repuestos** (ver página 38)

**XXX = Acabados**

000 = cromado

820 = brushed nickel

**Opcional** (no incluido en el suministro)



Pieza desuplemento #97450XXX  
(ver página 38)



**Marca de verificación**  
(ver página 40)



**Montaje ver página 32**



## Veiligheidsinstructies

- ⚠ Bij de montage moeten ter voorkoming van knel- en snijwonden handschoenen worden gedragen.
- ⚠ Het product mag alleen voor het wassen, hygiënische doeleinden en voor de lichaamsreiniging worden gebruikt.
- ⚠ Het product mag niet als handgreep worden gebruikt. Er moet een aparte handgreep gemonteerd worden.
- ⚠ De doucheslangen zijn alleen geschikt voor de aansluiting van douches aan kranen. Een versperping ná de doucheslang in de stroomrichting is niet toelaatbaar.

## Montage-instructies

- Vóór de montage moet het product gecontroleerd worden op transportschade. Na de inbouw wordt geen transport- of oppervlakteschade meer aanvaard.
- De leidingen en armaturen moeten gemonteerd, gespoeld en gecontroleerd worden volgens de geldige normen.
- De in de overeenkomstige landen geldende installatierichtlijnen moeten nageleefd worden.
- Thermostaat: Bediening / Montage zie bijgevoegde brochure.
- Bij de montage van het product door gekwalificeerd vakpersoneel moet erop gelet worden dat het montagevlak in het volledige bereik van de bevestiging vlak is (geen uitstekende voegen of verspringende tegels), dat de wand geschikt is voor de montage van het product en geen zwakke plaatsen vertoont.
- Optimal functioneren gegarandeerd bij combinatie met Hansgrohe handdouche en doucheslang.

## Symboolbeschrijving



Gebruik geen zuurhoudende silicone!



**Maten** (zie blz. 34)



**Bediening** (zie blz. 31)



**Reinigen**

zie bijgevoegde brochure



**Service onderdelen** (zie blz. 38)

**XXX = Kleuren**

000 = verchromd

820 = brushed nickel

**Toebehoren** (behoort niet tot het leveringspakket)

opvulschijf #97450XXX

(zie blz. 38)



**Keurmerk** (zie blz. 40)



**Montage zie blz. 32**





## Sikkerhedsanvisninger

- ⚠ Ved monteringen skal der bruges handsker for at undgå kvæstelser og snitsår.
- ⚠ Produktet må kun bruges til bade-, hygiejne og kropsrengøringsformål.
- ⚠ Produktet må ikke bruges som håndtag. Der skal monteres et separat håndtag.
- ⚠ Bruserslanger bør kun anvendes i forbindelse med tilslutning mellem brusere og armatur. Det er ikke tilladt at montere en afspærringsventil mellem brusere og slange!

## Monteringsanvisninger

- Før monteringen skal produktet kontrolleres for transportskader. Efter monteringen godkendes transportskader eller skader på overfladen ikke længere.
- Ledningerne og armaturerne skal monteres, skylles og kontrolleres iht. de gældende standarder.
- Installationsbestemmelserne, der gælder i det enkelte land, skal overholdes.
- Termostat: Brugsanvisning / Montering se venligst den vedlagte brochure.
- Ved montering af produktet igennem kvalificerede fagfolk skal der holdes øje med, at fastgørelsesoverfladen er plan i alle områder hvor produktet monteres (ingen fremragende fuger eller fliseforskydninger), at væggene er velegnet til monteringen af produktet og ikke har svare områder.
- Optimal funktion garanteres for anvendelse i forbindelse med Hansgrohe håndbrusere og Hansgrohe bruseslanger.

## Symbolbeskrivelse



Der må ikke benyttes eddikesyreholdig silikone!



**Målene** (se s. 34)



**Brugsanvisning** (se s. 31)



**Rengøring**

se venligst den vedlagte brochure



**Reserve dele** (se s. 38)

**XXX = Overflade**

000 = Krom

820 = Brushed nickel

**Specialtilbehør** (ikke med i leveringsomfang)

Afstandsskive #97450XXX

(se s. 38)



**Godkendelse** (se s. 40)





## Avisos de segurança

- ⚠ Durante a montagem devem ser utilizadas luvas de protecção, de modo a evitar ferimentos resultantes de entalamentos e de cortes.
- ⚠ O produto só pode ser utilizado para fins de higiene pessoal.
- ⚠ O produto não pode ser utilizado como pega de apoio. Tem que ser montada uma pega separada.
- ⚠ Os tubos flexíveis são apenas adequados para uma ligação do chuveiro à misturadora. Nunca instale uma válvula de corte entre a misturadora e o tubo flexível.

## Avisos de montagem

- Antes da montagem deve-se controlar o produto relativamente a danos de transporte. Após a montagem não são aceites quaisquer danos de transporte ou de superfície.
- As tubagens e a torneira têm que ser montadas, enxaguadas e verificadas de acordo com as normas em vigor.
- A prescrições de instalação válidas nos respetivos países devem ser respeitadas.
- Misturadora termostática: Funcionamento / Montagem consultar a seguinte brochura.
- Durante a montagem efectuada por técnicos qualificados deve ter-se em atenção que a superfície de fixação seja plana em toda a sua extensão (sem juntas ou ladrilhos salientes), que a estrutura da parede seja adequada para a montagem do produto e que não apresente pontos fracos.
- O bom funcionamento é apenas garantido em combinação com chuveiros de mão e tubos flexíveis Hansgrohe.

## Descrição do símbolo



Não utilizar silicone que contenha ácido acético!



**Medidas** (ver página 34)



**Funcionamento** (ver página 31)



**Limpeza**

consultar a seguinte brochura



**Peças de substituição** (ver página 38)

**XXX = Acabamentos**

000 = cromado

820 = brushed nickel

**Acessórios especiais** (não incluído no volume de fornecimento)



Arruela espaçadora #97450XXX  
(ver página 38)



**Marca de controlo**  
(ver página 40)





## Wskazówki bezpieczeństwa

- ⚠ Aby uniknąć zranień na skutek zgniecenia lub przecięcia, podczas montażu należy nosić rękawice ochronne.
- ⚠ Produkt może być używany tylko do kąpieli, higieny i czyszczenia ciała.
- ⚠ Produktu nie wolno używać jako uchwytu do trzymania się. Należy zamontować osobny uchwyt.
- ⚠ Wężę prysznicowe przeznaczone są do podłączenia tylko z armaturą. Blokada za wężem w kierunku przepływu jest niedopuszczalna.

## Wskazówki montażowe

- Przed montażem należy skontrolować produkt pod kątem szkód transportowych. Po montażu nie widać żadnych szkód transportowych ani szkód na powierzchni.
- Przewody i armatura muszą być montowane, płukane i kontrolowane według obowiązujących norm.
- Należy przestrzegać wytycznych instalacyjnych obowiązujących w danym kraju.
- Termostat: Obsługa / Montaż patrz dołączona broszura.
- Montaż produktu musi być wykonany przez wykwalifikowanego fachowca. Powierzchnia w miejscu montażu musi być równa (bez uskoków wzgl. wzajemnie przesuniętych płytek). Ściana w miejscu montażu musi być stabilna. Dołożone w komplecie śruby i kołki rozporowe są przeznaczone do betonu.
- Optymalne działanie gwarantuje się tylko w odniesieniu do pryszniców ręcznych i węży prysznicowych Hansgrohe.

## Opis symbolu



Nie stosować silikonów zawierających kwas octowy!



**Wymiary** (patrz strona 34)



**Obsługa** (patrz strona 31)



**Czyszczenie**

patrz dołączona broszura



**Części serwisowe** (patrz strona 38)

**XXX = Kody kolorów**

000 = chrom

820 = nikiel szorowany

**Wyposażenie specjalne** (Nie jest częścią dostawy)

Podkładka do wyrównania płytek ceramicznych #97450XXX (patrz strona 38)



**Znak jakości** (patrz strona 40)



**Montaż patrz strona 32**



## **Bezpečnostní pokyny**

- ⚠ Pro zabránění řezným zraněním a pohmožděninám je nutné při montáži nosit rukavice.
- ⚠ Produkt smí být používán pouze ke koupání a za účelem tělesné hygieny.
- ⚠ Produkt nesmí být používán jako madlo. Je nutné namontovat samostatné madlo.
- ⚠ Sprchové hadice jsou vhodné pouze pro napojení sprch na armatury. Řazení uzavíracího ventilu za hadici po směru toku je nepřipustné!

## **Pokyny k montáži**

- Před montáží je třeba produkt zkontrolovat, zda nebyl při transportu poškozen. Po zabudování nebudou uznány žádné škody způsobené transportem nebo poškození povrchu.
- Vedení a armatura musí být namontovány, propláchnuty a otestovány podle platných norem.
- Je třeba dodržovat montážní pravidla platné v dané zemi.
- Termostat: Ovládání / Montáž viz příložená brožura.
- Při montáži produktu kvalifikovanou osobou je třeba dbát na to, aby byla upevňovací plocha v celé oblasti upevnění rovná (žádné vyčnívající spáry nebo zapuštění obkladů), aby struktura stěny byla vhodná pro montáž produktu a neměla žádná slabá místa.
- Optimální funkce je zaručena pouze s ručními sprchami a sprchovými hadicemi Hansgrohe.

## **Popis symbolů**



Nepoužívat silikon s obsahem kyseliny octové!



**Rozměry** (viz strana 34)



**Ovládání** (viz strana 31)



**Čištění**

viz příložená brožura



**Servisní díly** (viz strana 38)

**XXX = Kód povrchové úpravy**

000 = chrom

820 = brushed nickel

**Zvláštní příslušenství** (není součástí dodávky)



destička pro vyrovnání obkladů #97450XXX (viz strana 38)



**Zkušební značka** (viz strana 40)



**Montáž viz strana 32**



## **Bezpečnostné pokyny**

- ⚠ Pri montáži musíte nosiť rukavice, aby ste predišli pomliaždeninám a rezným poraneniam.
- ⚠ Produkt sa smie používať len na kúpanie a telesnú hygienu.
- ⚠ Výrobok sa nesmie používať ako držadlo. K tomu účelu sa musí namontovať samostatné držadlo.
- ⚠ Sprchové hadice sú vhodné iba pre napojenie sprích na batérie. Umiestnenie uzatváracieho ventilu za hadicou v smere toku je neprípustné.

## **Pokyny pre montáž**

- Pred montážou musíte produkt skontrolovať, či nebol počas transportu poškodený. Po zabudovaní nebudú uznané žiadne škody spôsobené transportom alebo poškodenia povrchu.
- Ledningarna och blandaren måste monteras, spolás igenom och kontrolleras enligt de gällande normerna.
- Je potrebné dodržiavať smernice o inštalácii, ktoré sú práve teraz platné v krajinách.
- Termostatická batéria: Obsluha / Montáž nájdete v priloženej brožúre.
- Pri montáži produktu kvalifikovanou osobou treba dávať pozor na to, aby bola upevňovacia plocha v celej oblasti upevnenia rovná (žiadne vyčnievajúce medzery alebo zapustenia obkladov), aby štruktúra steny bola vhodná pre montáž produktu a nemá žiadne slabé miesta.
- Optimálna funkcia je zaručená iba s ručnými sprchami a sprchovými hadicami Hansgrohe.

## **Popis symbolov**



Nepoužívať silikón s obsahom kyseliny octovej!



**Rozmery** (viď strana 34)



**Obsluha** (viď strana 31)



**Čistenie**

nájdete v priloženej brožúre



**Servisné diely** (viď strana 38)

**XXX = Farebné označenie**

000 = chróm

820 = brushed nickel

**Zvláštne príslušenstvo** (nie je súčasťou dodávky)



doštička pre vyrovnanie obkladov  
#97450XXX (viď strana 38)



**Osvedčenie o skúške**  
(viď strana 40)





## 安全技巧

- △ 装配时为避免挤压和切割受伤，必须戴上手套。
- △ 本产品只允许作为洗浴、卫生和洁身之用。
- △ 该产品不得作扶柄使用。必须安装单独的扶柄。
- △ 淋浴软管只适合从淋浴器连接到管接头。切勿在管接头和软管之间安装截止装置。

## 安装提示

- 安装前必须检查产品是否受到运输损害。安装后将不认可运输损害或表面损伤。
- 管道和阀门必须根据通用标准进行安装、冲洗和检查。
- 请遵守当地国家现行的安装规定。
- 恒温龙头：操作 / 安装 附有小手册
- 由有资格的专业人员进行产品安装时请注意：在所有加固区域中，加固表面是否平整（无突出的接缝或瓷砖），墙体结构是否适合产品安装且未显露出任何缺点。
- 只有与汉斯格雅手提花洒和汉斯格雅淋浴器软管组合使用，方担保最佳的功能。

## 符号说明

 请勿使用含有乙酸的硅胶！

 大小 (参见第页 34)

 操作 (参见第页 31)

 清洗  
附有小手册

 备用零件 (参见第页 38)

**XXX** = 颜色代码

000 = 镀铬

820 = 镍拉丝

**选装附件** (不在供货范围内)

 匹配瓷砖的圆盘 #97450XXX  
(参见第页 38)

 检验标记 (参见第页 40)



**安装 参见第页 32**



## Указания по технике безопасности

- ⚠ Во время монтажа следует надеть перчатки во избежание прищемления и порезов.
- ⚠ Изделие разрешается использовать только в гигиенических целях: для принятия ванны и личной гигиены.
- ⚠ Изделие запрещается использовать в качестве рукоятки. Следует устанавливать специальную рукоятку.
- ⚠ Душевые шланги подходят только для подсоединения душей к арматуре. Не устанавливайте дополнительных затворов между шлангом и арматурой!

## Указания по монтажу

- Перед монтажом следует проверить изделие на предмет повреждений при перевозке. После монтажа претензии о возмещении ущерба за повреждения при перевозке или повреждения поверхностей не принимаются.
- Трубы и арматура должны быть установлены, промыты и проверены в соответствии с действующими нормами.
- Необходимо соблюдать требования по монтажу, действующие в соответствующих странах.
- Термостат: Эксплуатация / Монтаж см прилагаемая брошюра
- Во время монтажа изделия квалифицированным персоналом поверхность крепления должна быть ровной по всей области крепления (не допускайте выступающих стыков или перекоса облицовочной плитки); для монтажа изделия следует использовать подходящую стену достаточной прочности.
- Оптимальное функционирование гарантируется только при использовании в комбинации с ручными душами Hansgrohe и душевыми шлангами Hansgrohe.

## Описание символов



Не применяйте силикон, содержащий искусственную кислоту.



**Размеры** (см. стр. 34)



**Эксплуатация** (см. стр. 31)



**Очистка**

см прилагаемая брошюра



**Комплект** (см. стр. 38)

**XXX = Цветная кодировка**

000 = хром

820 = brushed nickel

**Специальные принадлежности** (не включено в объем поставки!)

Шайба для выравнивания с уровнем плитки #97450XXX (см. стр. 38)



**Знак технического контроля** (см. стр. 40)





## Biztonsági utasítások

- ⚠ A szerelésnél a zúzódások és vágási sérülések elkerülése érdekében kesztyűt kell viselni.
- ⚠ A terméket csak fürdéshez, mosakodáshoz, és egészségügyi tisztálkodáshoz szabad használni.
- ⚠ A terméket nem szabad kapaszkodónak használni. Ehhez külön kapaszkodót kell felszerelni.
- ⚠ A zuhanycsövek kizárólag zuhanyok csaptelepekkel való összekötésére alkalmasak. A zuhanycső után (folyásirány szerint) elzárás beszerelése nem engedélyezett!

## Szerelési utasítások

- A szerelés előtt ellenőrizni kell, hogy a terméknek nincs-e szállítási sérülése. Beépítés után a szállítási- vagy felületi sérüléseket nem ismerik el.
- A vezetékeket és a csaptelepet az érvényes szabványoknak megfelelően kell felszerelni, öblíteni és ellenőrizni
- Az egyes országokban érvényes installációs irányelveket be kell tartani.
- Termosztát: Használat / Szerelés lásd a mellékelt brosúrát.
- A termék képzett szakember általi felszerelése esetén ügyelni kell arra, hogy a rögzítési felület teljesen sima legyen (ne legyen kiálló fuga vagy csempe), a fal szerkezete a termék felszerelésére alkalmas legyen, és ne legyen gyenge pontja.
- A megfelelő működést csak Hansgrohe kézi zuhanyokkal és Hansgrohe zuhanycsövekkel garantáljuk.

## Szimbólumok leírása



Ne használjon ecetsavtartalmú szilikon!



**Méretet** (lásd a oldalon 34)



**Használat** (lásd a oldalon 31)



**Tisztítás**

lásd a mellékelt brosúrát



**Tartozékok** (lásd a oldalon 38)

**XXX = Színkódolás**

000 = króm

820 = brushed nickel

**Egyéb tartozék** (a szállítási egység nem tartalmazza)

Csempekiegyenlítő lemez #97450XXX  
(lásd a oldalon 38)



**Vizsgajel** (lásd a oldalon 40)



**Szerelés lásd a oldalon 32**





## Turvallisuusohjeet

- △ Asennuksessa on käytettävä käsiineitä puristumien ja viiltojen aiheuttamien tapaturmien estämiseksi.
- △ Tuotetta saa käyttää ainoastaan kylpy-, hygienia- ja puhdistustarkoituksiin.
- △ Tuotetta ei saa käyttää kädensijana. On asennettava erillinen kädensija.
- △ Suihkuletkut soveltuvat vain käsisuihkun liittämiseen armatuureihin. Letkun jälkeen virtausuunnassa oleva sulkuventtiili ei ole sallittua!

## Asennusohjeet

- Ennen asennusta on tarkastettava tuotteen mahdolliset kuljetusvahingot. Asennuksen jälkeen kuljetus- ja pintavaurioita ei hyväksytä.
- Putket ja hana on asennettava, huuhdeltava ja tarkastettava voimassa olevien standardien mukaisesti.
- Jokaisessa maassa on noudatettava siellä päteviä asennusohjeita.
- Termostaatti: Käyttö / Asennus katso oheinen esite
- Pätevän ammattihenkilöstön asentaessa tuotetta on otettava huomioon, että kiinnityspinnan on oltava koko kiinnitysalueelta tasainen (ei korkeita saumoja tai laattojen yhtymäkohtia), seinän rakenne soveltuu tuotteen asennukseen eikä siinä ole heikkoja kohtia.
- Optimaalinen toiminta on taattuna vain Hansgrohe käsisuihkuja ja Hansgrohe suihkuletkuja käytettäessä.

## Merkin kuvaus



Älä käytä etikahappopitoista silikonia!



**Mitat** (katso sivu 34)



**Käyttö** (katso sivu 31)



**Puhdistus**

katso oheinen esite



**Varaosat** (katso sivu 38)

**XXX = Värikoodaus**

000 = kromi

820 = harjattu nikkeli

**Erityisvaruste** (ei kuulu toimitukseen)



Laatansovituslevy #97450XXX

(katso sivu 38)



**Koestusmerkki** (katso sivu 40)





## Säkerhetsanvisningar

- △ Handskar ska bäras under monteringsarbetet så att man kan undvika kläm- och skärskadorgen werden.
- △ Produkten får bara användas till kroppshygien med bad och dusch.
- △ Produkten får inte användas som handtag. Ett separat handtag måste monteras.
- △ Duschslangar är endast avsedda till att ansluta duschar på blandare. Det är inte tillåtet att lägga in en spärr efter slangen och i flödesriktningen!

## Monteringsanvisningar

- Det måste undersökas om produkten har transportskador innan den monteras. Efter monteringen accepteras inga transport- eller ytskiktsskador.
- Ledningarna och blandaren måste monteras, spolats igenom och kontrolleras enligt de gällande normerna.
- De installationsriktlinjer som gäller i länderna ska följas.
- Termostat: Hantering / Montering se den medföljande broschyren
- När kvalificerad fackpersonal monterar produkten är det viktigt att fästytan är plan över hela fästsättningsområdet (inga fogar som sticker ut eller kakelförskjutning) och att väggstrukturen är lämplig för en montering av produkten och inte har några svaga punkter.
- Optimal funktion garanteras bar tillsammans med Hansgrohe handduschar och Hansgrohe duschslangar.

## Symbolförklaring



Använd inte silikon som innehåller ättiksyra!



**Måtten** (se sidan 34)



**Hantering** (se sidan 31)



**Rengöring**

se den medföljande broschyren



**Reservdelar** (se sidan 38)

**XXX = Färgkodning**

000 = krom

820 = borstad nickel



**Specialtillbehör** (medföljer ej leveransen)

Kakelutjämningsbricka #97450XXX  
(se sidan 38)



**Testsigill** (se sidan 40)





## Saugumo technikos nurodymai

- ⚠️ Apsaugai nuo užspaudimo ir įsijavimo montavimo metu mūvėkite pirštines.
- ⚠️ Gaminys turi būti naudojamas tik maudymuisi, kūno higienai ir švarai palaikyti.
- ⚠️ Gaminys neturi būti naudojamas kaip rankena. Rankena montuojama atskirai.
- ⚠️ Dušo žarnos yra pritaikytos tik prijungti dušo galvutę prie vandens maišytuvo. Negalima montuoti vandens uždarymo mechanizmo tarp maišytuvo ir žarnos.

## Montavimo instrukcija

- Prieš montuojant būtina patikrinti, ar gaminys nebuvo pažeistas transportavimo metu. Sumontavus pretenzijos dėl transportavimo ir paviršiaus pažeidimų nepriimamos.
- Vamzdžiai ir sujungimai turi būti montuojami, plaunami ir tikrinami pagal galiojančias normas.
- Laikykitės atitinkamoje šalyje galiojančių direktyvų dėl įrengimo.
- Termostatas: Eksploatacija / Montavimas žr. pridedamoje brošiūroje.
- Atlikdami montavimo darbus, kvalifikuoti darbuotojai turi atkreipti dėmesį, kad pritvirtinimo plokštuma būtų lygi (be išsikišusių siūlių ar perkreiptų plytelių), sienų konstrukcija tiktų gaminiui montuoti ir neturėtų jokių trūkumų.
- Optimalus funkcionavimas yra garantuojamas tik naudojant "Hansgrohe" rankų dušus su "Hansgrohe" dušo žarnomis.

## Simbolio aprašymas



Nenaudokite silikono, kurio sudėtyje yra acto rūgšties!



**Išmatavimai** (žr. psl. 34)



**Eksploatacija** (žr. psl. 31)



**Valymas**

žr. pridedamoje brošiūroje



**Atsarginės dalys** (žr. psl. 38)

**XXX = Spalvos**

000 = chrom

820 = brushed nickel

**Specialūs priedai** (nėra pridama)

Plytelių išlyginimo diskas #97450XXX  
(žr. psl. 38)



**Bandymo pažyma** (žr. psl. 40)





## Sigurnosne upute

- ⚠ Prilikom montaže se radi sprječavanja prignječenja i posjekotina moraju nositi rukavice.
- ⚠ Proizvod se smije primjenjivati samo za kupanje, tuširanje i osobnu higijenu.
- ⚠ Proizvod ne smije služiti za pridržavanje. U tu se svrhu mora postaviti zaseban rukohvat.
- ⚠ Crijeva tuša prikladna su jedino za spajanje tuševa na armature. Nije dopušteno zatvaranje crijeva u smjeru protoka vode!

## Upute za montažu

- Prije montaže mora se provjeriti je li proizvod oštećen prilikom transporta. Nakon ugradnje se ne priznaju nikakve reklamacije koje se odnose na površinska i transportna oštećenja.
- Cijevi i armatura moraju biti postavljeni, isprani i testirani prema važećim normama.
- Obvezno se moraju uvažiti propisi o instalacijama koji vrijede u dotičnoj zemlji.
- Termostat: Upotreba / Sastavljanje se u priloženoj brošuri.
- Kada proizvod montira kvalificirano stručno osoblje treba paziti da čitava površina na koju se učvršćuje bude ravna (bez istaknutih fuga ili krivljenja pločica), da je zidna konstrukcija primjerena montaži proizvođača te da nema slabih mjesta.
- Optimalno funkcioniranje zajamčeno je jedino u kombinaciji sa Hansgrohe ručnim tuševima i Hansgrohe crijevom za tuš.

## Opis simbola



Nemojte koristiti silikon koji sadrži octenu kiselinu!



**Mjere** (pogledaj stranicu 34)



**Upotreba** (pogledaj stranicu 31)



**Čišćenje**

se u priloženoj brošuri



**Rezervni djelovi** (pogledaj stranicu 38)

**XXX = Boje**

000 = krom

820 = brushed nickel

**Posebni pribor** (Nije sadržano u isporuci!)



Sustav za balansiranje protoka #97450XXX (pogledaj stranicu 38)



**Oznaka testiranja** (pogledaj stranicu 40)





## ⚠ Güvenlik uyarıları

- ⚠ Montaj esnasında ezilme ve kesilme gibi yaralanmaları önlemek için eldiven kullanılmalıdır.
- ⚠ Ürün yalnızca banyo, hijyen ve beden temizliği amaçları doğrultusunda kullanılabilir.
- ⚠ Ürün tutma kolu olarak kullanılmamalıdır. Aynı bir tutma kolu monte edilmelidir.
- ⚠ Sözü geçen duş boruları, duş parçalarını yalnız donanım takımlarına bağlamaya yarar. Hortumun arkasından sonra akış yönünde kesmek yasaktır!

## Montaj açıklamaları

- Montaj işleminden önce ürün nakliye hasarları yönünden kontrol edilmelidir. Montaj işleminden sonra nakliye veya yüzey hasarları için sorumluluk üstlenilmemektedir.
- Boruların ve armatürün montajı, yıkanması ve kontrolü geçerli normlara göre yapılmalıdır.
- Ülkelerde geçerli kurulum yönetmeliklerine riayet edilmelidir.
- Termostat: Kullanımı / Montajı birlikte verilen broşür
- Ürünün yetkili uzman personel tarafından montajı yapılırken, sabitleme yüzeyinin sabitleme planının tüm alanında bulunduğu (derz veya fayans kayması olmamalıdır), duvar yapısının ürünün montajı için uygun olduğuna ve zayıf noktaları bulunmadığına dikkat edilmelidir.
- Mümkün olduğu kadar iyi işlev, yalnız Hansgrohe elle duş parçaları ve Hansgrohe duş boruları kullanılırsa, garanti edilir.

## Simge açıklaması



Asetik asit içeren silikon kullanmayın!



**Ölçüleri** (bakınız sayfa 34)



**Kullanımı** (bakınız sayfa 31)



**Temizleme**

birlikte verilen broşür



**Yedek Parçalar** (bakınız sayfa 38)

**XXX = Renkler**

000 = krom

820 = brushed nickel

**Özel aksesuarlar** (Teslimat kapsamına dahil değildir)

Fayans dengeleme pulu #97450XXX  
(bakınız sayfa 38)



**Kontrol işareti** (bakınız sayfa 40)



**Montajı bakınız sayfa 32**



## Instrucțiuni de siguranță

- ⚠ La montare utilizați mănuși pentru evitarea contuziunilor și tăierii mâinilor.
- ⚠ Produsul poate fi utilizat doar pentru spălarea, menținerea igienei și curățarea corpului.
- ⚠ Nu este permisă utilizarea produsului pe post de mâner. este nevoie de montarea unui mâner corespunzător.
- ⚠ Furtunul de duș poate fi utilizat numai pentru conectarea telefonului de duș la baterie. Nu este permisă montarea unui opritor la capătul furtunului!

## Instrucțiuni de montare

- Înainte de instalare verificați, dacă produsul prezintă deteriorări de transport. După instalare garanția nu acoperă deteriorările de transport și cele de suprafață.
- Conductele și bateriile trebuie montate, spălate și verificate conform normelor în vigoare.
- Respectați reglementările referitoare la instalare valabile în țara respectivă.
- Termostat: Utilizare / Montare vezi broșura alăturată.
- La montarea produsului de către un personal calificat se va avea grijă ca suprafața de fixare să fie plană pe toată aria de fixare (fără proeminențe ale rosturilor sau îmbinări între plăcile de faianță) și ca structura peretelui să fie corespunzătoare pentru fixarea produsului, să nu prezinte locuri cu rezistență redusă.
- Funcționarea optimă este garantată numai când este conectat la duș de mână și furtun de duș marca Hansgrohe.

## Descrierea simbolurilor



Nu utilizați silicon cu conținut de acid acetic!



**Dimensiuni** (vezi pag. 34)



**Utilizare** (vezi pag. 31)



**Curățare**

vezi broșura alăturată



**Piese de schimb** (vezi pag. 38)

**XXX = Coduri de culori**

000 = crom

820 = nichel mat

**Accesorii opționale** (nu este inclus în setul livrat)



Șaibă de reglare a debitului #97450XXX (vezi pag. 38)



**Certificat de testare** (vezi pag. 40)



**Montare vezi pag. 32**



## ⚠ Υποδείξεις ασφαλείας

- ⚠ Για να αποφύγετε τραυματισμούς κατά τη συναρμολόγηση πρέπει να φοράτε γάντια.
- ⚠ Το προϊόν επιτρέπεται να χρησιμοποιείται μόνο σαν μέσο λουτρού, υγιεινής και καθαρισμού του σώματος.
- ⚠ Το προϊόν δεν επιτρέπεται να χρησιμοποιείται σαν λαβή στήριξης. Για τον σκοπό αυτό πρέπει να τοποθετηθεί ξεχωριστή λαβή στήριξης.
- ⚠ Το εύκαμπτο σπирάλ του καταιονιστήρα είναι κατάλληλο μόνο για τη σύνδεση του καταιονιστήρα χειρός με τη βάνα. Δεν επιτρέπεται καμία στρόφιγγα διακοπής μετά το σωλήνα στην κατεύθυνση ροής!

## Οδηγίες συναρμολόγησης

- Πριν τη συναρμολόγηση πρέπει να εξεταστεί το προϊόν για ζημιές μεταφοράς. Μετά την εγκατάσταση δεν αναγνωρίζονται ζημιές από τη μεταφορά ή επιφανειακές ζημιές.
- Οι σωλήνες και η μπαταρία πρέπει να τοποθετηθούν σύμφωνα με τα ισχύοντα πρότυπα, να τεθούν υπό πίεση και να δοκιμαστούν.
- Θα πρέπει να τηρούνται οι οδηγίες εγκατάστασης που ισχύουν σε κάθε κράτος.
- Θερμοστάτης: Χειρισμός / Συναρμολόγηση βλ. συνημμένο φυλλάδιο
- Κατά τη συναρμολόγηση του προϊόντος από ειδικό προσωπικό θα πρέπει να ελέγχεται με ιδιαίτερη προσοχή η επιφάνεια στερέωσης, αν είναι επίπεδη σε όλη της την επιφάνεια (δεν πρέπει να εξέχουν αρμοί ή πλακάκια), αν η υποδομή του τοίχου είναι κατάλληλη για τη στερέωση του προϊόντος και αν παρουσιάζει ασθενή σημεία.
- Εγγύηση βέλτιστης λειτουργίας μόνο σε συνδυασμό με καταιονιστήρα χειρός Hansgrohe και σπирάλ Hansgrohe.

## Περιγραφή συμβόλων



Μην χρησιμοποιείτε σιλικόνη που περιέχει οξικό οξύ!



**Διαστάσεις** (βλ. Σελίδα 34)



**Χειρισμός** (βλ. Σελίδα 31)



**Καθαρισμός**

βλ. συνημμένο φυλλάδιο



**Ανταλλακτικά** (βλ. Σελίδα 38)

**XXX = Χρώματα**

000 = Επιχρωμιωμένο

820 = νικελ ματ

**Ειδικά αξεσουάρ** (δεν περιλαμβάνεται στον παραδοτέο εξοπλισμό)

Δίσκος αντιστάθμισης πλακιδίων

#97450XXX (βλ. Σελίδα 38)



**Σήμα ελέγχου** (βλ. Σελίδα 40)





## Varnostna opozorila

- ⚠ Pri montaži je treba nositi rokavice, da se preprečijo poškodbe zaradi zmečkanja ali urezov.
- ⚠ Ta izdelek se sme uporabljati le z namenom umivanja, vzdrževanja higiene in telesne nege.
- ⚠ Proizvoda ne smete uporabljati kot držalnega ročaja. V ta namen je treba montirati poseben ročaj.
- ⚠ Gibke cevi za prho so primerne le za povezavo prhe in armature. Naprave za zapiranje pretoka vode nikoli ne nameščajte med armaturo in cev.

## Navodila za montažo

- Pred montažo je treba izdelek preveriti glede morebitnih transportnih poškodb. Po vgradnji transportne ali površinske poškodbe ne bodo več priznane.
- Cevi in armaturo je treba montirati, izprati in preveriti po veljavnih standardih.
- Upoštevati je treba pravilnike o inštalacijah, ki veljajo v posamezni državi.
- Termostat: Upravljanje / Montaža glejte priloženi brošuri.
- Pri montaži tega proizvoda s strani kvalificiranega strokovnega osebja je treba paziti na to, da je pritrilna ploskev na celotni površini za pritrnitev gladka (brez izstopajočih fug ali zasekov ploščic), da je struktura stene primerna za montažo proizvoda in ne kaže šibkih mest.
- Optimalno delovanje je zagotovljeno le v povezavi z ročnimi prhami Hansgrohe in gibkimi cevmi za prho Hansgrohe.

## Opis simbola



Ne smete uporabiti silikona, ki vsebuje očetno kislino!



**Mere** (glejte stran 34)



**Upravljanje** (glejte stran 31)



**Čiščenje**

glejte priloženi brošuri



**Rezervni deli** (glejte stran 38)

**XXX = Barve**

000 = krom

820 = brushed nickel

**Poseben pribor** (Ni vključeno)



Izravnalna podložka za ploščice  
#97450XXX (glejte stran 38)



**Preskusni znak** (glejte stran 40)



**Montaža glejte stran 32**





## ⚠ Ohutusjuhised

- ⚠ Kandke paigaldamisel muljumis- ja löikevigastuste vältimiseks kindaid.
- ⚠ Toodet tohib kasutada ainult pesemis-, hügieeni- ja kehapuhastamisesmärkidel.
- ⚠ Toodet ei tohi kasutada käepidemena. Paigaldage eraldi käepide.
- ⚠ Dušivoolikud sobivad üksnes duši ühendamiseks segistitega. Mingil juhul ei tohi vooliku ja segisti vahele asetada sulgurit.

## Paigaldamisjuhised

- Enne paigaldamist tuleb toodet kontrollida transpordikahjustuste osas. Pärast paigaldamist ei tunnustata enam transpordi- või pinnakahjustuste kaebuseid.
- Voolikute ja segisti paigaldamisel, loputamisel ja kontrollimisel tuleb lähtuda kehtivatest normatiividest.
- Vastavas riigis kehtivaid paigalduseeskirju tuleb järgida.
- Termostaat: Kasutamine / Paigaldamine vt kaasasolevast brošüürist.
- Toote paigaldamisel kvalifitseeritud spetsialistide poolt tuleb jälgida, et kinnituspind oleks kogu ulatuses ühtlaselt tasane (mitte ühtki üleseisvat vuuki või kaldus kahhelkivi), seina ülesehitus toote paigaldamiseks sobiv ja ilma nõrkade kohtadeta.
- Optimaalne funktsioneerimine on garanteeritud ainult koos Hansgrohe käsiduššide ja Hansgrohe dušivoolikutega.

## Sümbolite kirjeldus



Ärge kasutage äädikhapet sisaldavat silikooni!



**Mõõtude** (vt lk 34)



**Kasutamine** (vt lk 31)



**Puhastamine**

vt kaasasolevast brošüürist



**Varuosad** (vt lk 38)

**XXX = Värvid**

000 = kroom

820 = brushed nickel

**Spetsiaalne lisavarustus** (ei sisaldu komplektis)

vaheelement keraamiliste plaatide tasakaalustamiseks #97450XXX (vt lk 38)



**Kontrollsertifikaat** (vt lk 40)





## Drošības norādes

- △ Montāžas laikā, lai izvairītos no saspiedumiem un iegriezumiem, nepieciešams nēsāt cimdus.
- △ Šo produktu drīkst izmantot tikai, lai mazgātos, higiēnai un ķermeņa tīrīšanai.
- △ Šo produktu nedrīkst izmantot kā roku balstu. Nepieciešams uzmontēt atsevišķu roku balstu.
- △ Dušas šļūtenes ir piemērotas tikai dušas pieslēgšanai pie jaucējkrāna. Nepieļaujama ir noslēgarmatūras pievienošana aiz šļūtenes plūsmas virzienā!

## Norādījumi montāžai

- Pirms montāžas nepieciešams pārbaudīt, vai produktam transportēšanas laikā nav radušies bojājumi. Pēc iebūvēšanas bojājumi, kas radušies transportēšanas laikā, vai virsmas bojājumi netiek atzīti.
- Cauruļvadi un armatūra ir jāuzstāda, jāizskalo un jāpārbauda saskaņā ar spēkā esošajiem standartiem.
- Jāievēro attiecīgās valstīs spēkā esošās montāžas prasības.
- Termostats: Lietošana / Montāža skatiet pievienotajā brošūrā.
- Kvalificētiem speciālistiem, montējot produktu, jāpiegriež vērība tam, lai piestiprināšanas virsma visā piestiprināšanas zonā ir gluda (nav fūgu vai flīžu iecirtumu), sienas uzbūve ir piemērota produkta montāžai un tajā nav nestabilu vietu.
- Optimāla funkcija tiek garantēta tikai kombinācijā ar Hansgrohe rokas dušām un Hansgrohe dušas šļūtenēm.

## Simbolu nozīme



Neizmantot silikonu, kas satur etiķskābi!



**Izmērus** (skat. lpp. 34)



**Lietošana** (skat. lpp. 31)



**Tīrīšana**

skatiet pievienotajā brošūrā



**Rezerves daļas** (skat. lpp. 38)

**XXX = Krāsu kodi**

000 = hroma

820 = brushed nickel

**Speciāli aksesuāri** (komplektā netiek piegādāts)

Flīžu izlīdzināšanas ripa #97450XXX (skat. lpp. 38)



**Pārbaudes zīme** (skat. lpp. 40)





## Sigurnosne napomene

- ⚠ Prilikom montaže se radi sprečavanja prignječenja i posekotina moraju nositi rukavice.
- ⚠ Proizvod sme da se koristi samo za kupanje, tuširanje i ličnu higijenu.
- ⚠ Proizvod se ne sme koristiti za kao ručka za pridržavanje. U tu svrhu se mora postaviti zaseban rukohvat.
- ⚠ Creva tuša prikladna su jedino za spajanje tuševa na armature. Nije dopušteno blokiranje creva u smeru protoka vode!

## Instrukcije za montažu

- Pre montaže se mora proveriti da li je proizvod oštećen pri transportu. Nakon ugradnje se ne priznaju nikakve reklamacije koje se odnose na površinska i transportna oštećenja.
- Vodovi i armatura moraju biti postavljeni, isprani i testirani prema važećim normama.
- Treba se pridržavati propisa koji u određenim zemljama važe za instalacije.
- Termostat: Rukovanje / Montaža vidi priloženoj brošuri.
- Kada proizvod montira kvalifikovano stručno osoblje treba paziti da čitava površina na koju se učvršćuje bude ravna (bez istaknutih fuga ili krivljenja pločica), da je zidna konstrukcija primerena montaži proizvoda i da nema slabih mesta.
- Optimalno funkcionisanje je garantovano jedino u kombinaciji sa Hansgrohe ručnim tuševima i Hansgrohe crevom za tuš.

## Opis simbola



Nemojte koristiti silikon koji sadrži sirćetnu kiselinu!



**Mere** (vidi stranu 34)



**Rukovanje** (vidi stranu 31)



**Čišćenje**

vidi priloženoj brošuri



**Rezervni delovi** (vidi stranu 38)

**XXX = Oznake boja**

000 = hrom

820 = brushed nickel

**Poseban pribor** (Nije sadržano u isporuci)

Sistem za balansiranje protoka #97450XXX (vidi stranu 38)



**Ispitni znak** (vidi stranu 40)





## Sikkerhetshenvisninger

- △ Bruk hansker under montasjen for å unngå klem- og kuttskader.
- △ Produktet skal kun brukes for bade-, hygiene- og kroppshygiene.
- △ Produktet skal ikke brukes som holdegrep. Det skal monteres en separat holdegrep.
- △ Dusj slanger er kun egnet for tilkobling av dusj til armaturer. Det er ikke tillatt med en avsperring etter slangen i gjennomstrømningsretning!

## Montagehenvisninger

- Før montasjen skal produktet sjekkes for transportskader. Etter monteringen aksepteres ikke noen transport- eller overflateskader.
- Ledningene og armaturen skal monteres, spyles og sjekkes iht. de gyldige normer.
- Gjeldende retningslinjer for rørleggerarbeid i de enkelte land skal følges.
- Termostat: Betjening / Montasje se vedlagt brosjyre.
- Under monteringen av produktet gjort av kvalifisert fagpersonell, skal man påse at monteringsoverflaten på hele festeområdet er plant (ingen utstikkende fuger eller flisekanter), at veggoppbyggingen egner seg for produktmontasjen og ikke viser svake punkter.
- Optimal funksjon garanteres kun i forbindelse med Hansgrohe hånddusj og Hansgrohe dusjslanger.

## Symbolbeskrivelse



Ikke bruk silikon som inneholder eddiksyre!



**Mål** (se side 34)



**Betjening** (se side 31)



**Rengjøring**

se vedlagt brosjyre



**Service-deler** (se side 38)

**XXX = Fargekode**

000 = krom

820 = børstet nikkell

**Ekstratilbehør** (ikke med i leveransen)



Utligningsskive for fliser #97450XXX (se side 38)



**Prøve-merke** (se side 40)





## Указания за безопасност

- ⚠ При монтажа трябва да се носят ръкавици, за да се избегнат наранявания поради притискане или порязване.
- ⚠ Позволено е използването на продукта само за къпане, хигиена и цели на почистване на тялото.
- ⚠ Продуктът не бива да се използва като дръжка. Трябва да се монтира отделна дръжка.
- ⚠ Маркучите на разпръсквателите са подходящи само за свързване на разпръскватели към арматури. Не се допуска блокиране след маркуча по посоката на протичане!

## Указания за монтаж

- Преди монтажа продуктът трябва да се провери за транспортни щети. След монтажа не се признават транспортни или повърхностни щети.
- Тръбопроводите и арматурата трябва да се монтират, промият и проверят в съответствие с валидните норми.
- Трябва да бъдат спазвани валидните в съответните страни предписания за инсталиране.
- Термостат: Обслужване / Монтаж от приложената брошура.
- При монтаж на продукта от квалифицирани специалисти да се внимава за това, закрепващата повърхност в целия диапазон на закрепването да бъде равна (без излъкнали фуги или изместване на плочки), конструкцията на стената да е подходяща за монтаж на продукта и да няма слаби места.
- Оптималното функциониране се гарантира само във връзка с ръчните разпръскватели и маркучите на разпръскватели на Hansgrohe.

## Описание на символите



Не използвайте силикон, съдържащ оцетна киселина!



**Размери** (вижте стр. 34)



**Обслужване** (вижте стр. 31)



**Почистване**

от приложената брошура



**Сервизни части** (вижте стр. 38)

**XXX = Цветово кодиране**

000 = хром

820 = надраскан никел

**Специални принадлежности**

(не се съдържа в обема на доставка)

Изравнителна шайба за плочки

#97450XXX (вижте стр. 38)



**Контролен знак** (вижте стр. 40)



**Монтаж вижте стр. 32**



## Udhëzime sigurie

- △ Për të evituar lëndimet e pickimeve ose të prerjeve gjatë procesit të montimit duhet që të vishni doreza.
- △ Produkti duhet të përdoret vetëm qëllimet e banjave, të higjienës dhe të larjes së trupit.
- △ Produkti nuk duhet të përdoret si dorëze mbajtëse. Duhet të montohet një dorëzë mbajtëse e veçantë
- △ Zorra e dushit mund të përdoren vetëm për lidhjen e spërkatëseve me armaturën. Ndalohet bllokimi pas zorrës në drejtim të rrjedhjes!

## Udhëzime për montimin

- Përpara montimit duhet që produkti të kontrollohet për dëmtime nga transporti. Pas instalimit nuk do të njihet asnjë dëmtim nga transporti ose dëmtim i sipërfaqes.
- Tubacionet dhe rubinetet duhet që të montohen, të shpëlahen dhe të kontrollohen sipas standardeve në fuqi
- Duhet të respektohen linjat udhëzuese të instalimit, të vlefshme për vendet respektive.
- Termostati: Përdorimi / Montimi shikoni broshurën bashkëngjitur.
- Gjatë montimit të produktit nga teknikët e specializuar duhet mbajtur parasysh që sipërfaqja e montimit gjendet brenda zonës së përgjithshme të planit të montimit (nuk ka vendbashkime të dala ose mospërputhje të pllakave), që struktura e murit është e përshtatshme për montimin e produktit dhe që nuk paraqet asnjë pikë të dobët.
- Garantohet funksioni optimal vetëm në kombinim me spërkatëset Hansgrohe si dhe zorrat e dushit Hansgrohe.

## Përshkrimi i simbolit



Mos përdorni silikon që në përbërje ka acid acetik.



**Përmasat** (shih faqen 34)



**Përdorimi** (shih faqen 31)



**Pastrimi**

shikoni broshurën bashkëngjitur



**Pjesët e servisit** (shih faqen 38)

**XXX = Kodimi me anë të ngjyrave**

000 = krom

820 = nikel i furçuar

**Pajisje të posaçme** (nuk përfshihet në vëllimin e furnizimit)

Pllaka për rrafshimin e pllakave të murit #97450XXX (shih faqen 38)



**Shenja e kontrollit**

(shih faqen 40)





## وصف الرمز

هام! لا تستخدم السليكون الذي يحتوي على أحماض!



أبعاد (راجع صفحة 34)



التشغيل (راجع صفحة 31)



## التنظيف



راجع والكتيب المرفق

قطع الغيار (راجع صفحة 38)



XXX = الألوان

000 = كروم

820 = نيكل مُفَرَّش

ملحقات خاصة (غير مدرج مع المحتويات المسلمة)

قرص مطابقة البلاط #97450XXX

(راجع صفحة 38)



شهادة اختبار (راجع صفحة 40)



## ⚠ تنبيهات الأمان

⚠ يجب إرتداء قفازات لليد أثناء التركيب لتجنب حدوث أخطار الإحشار أو الجروح.

⚠ لا يجب استخدام المنتج إلا في أغراض الاستحمام والأغراض الصحية وأغراض تنظيف الجسم.

⚠ ممنوع إستخدام المنتج كمقبض. يجب تركيب مقبض منفصل.

⚠ لا تصلح خراطيم الدش إلا للتوصيل من الدش إلى الوصلة. حذارٍ من تركيب جهاز إغلاق بين الوصلة والخراطيم.

## تعليمات التركيب

• قبل القيام بعملية التركيب، يجب فحص المنتج للتأكد من خلوه من أية تلفيات ناتجة عن النقل. بعد القيام بعملية التركيب، لن يتم الاعتراف بوجود أية تلفيات سطحية أو تلفيات ناتجة عن عملية النقل.

• يجب تركيب وغسيل واختبار التوصيلات وخلطات المياه طبقاً للمعايير السارية.

• يجب مراعاة القواعد الخاصة بالتركيب وأعمال السباكة وفقاً للوائح الخاصة بكل بلد.

• ثرموسنات: التشغيل / التركيب راجع والكتيب المرفق

• عند التركيب بواسطة عمال تركيب متخصصين يجب الإنتباه إلى أن مساحة التثبيت في مكان التركيب بوجه عام مسطحة (لا توجد روابط أو فروق للربط بين البلاطات). لذا يجب التأكد من أن الحائط الذي سيتم تركيب المنتج عليه صالح لذلك وأنه لا يوجد به نقاط ضعف.

• لا يمكن ضمان الحصول على الأداء الأمثل إلا من خلال الجمع بين الدش اليدوي إنتاج هانزجر وهه وخراطيم الدش إنتاج هانزجر وهه.



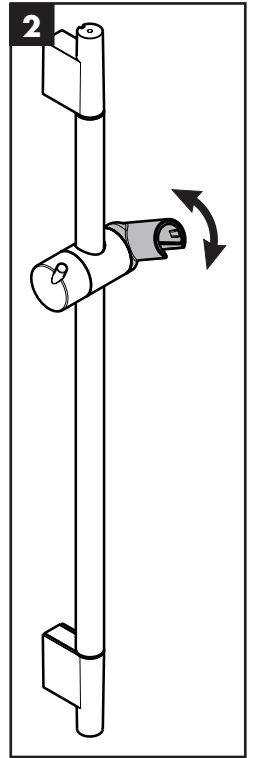
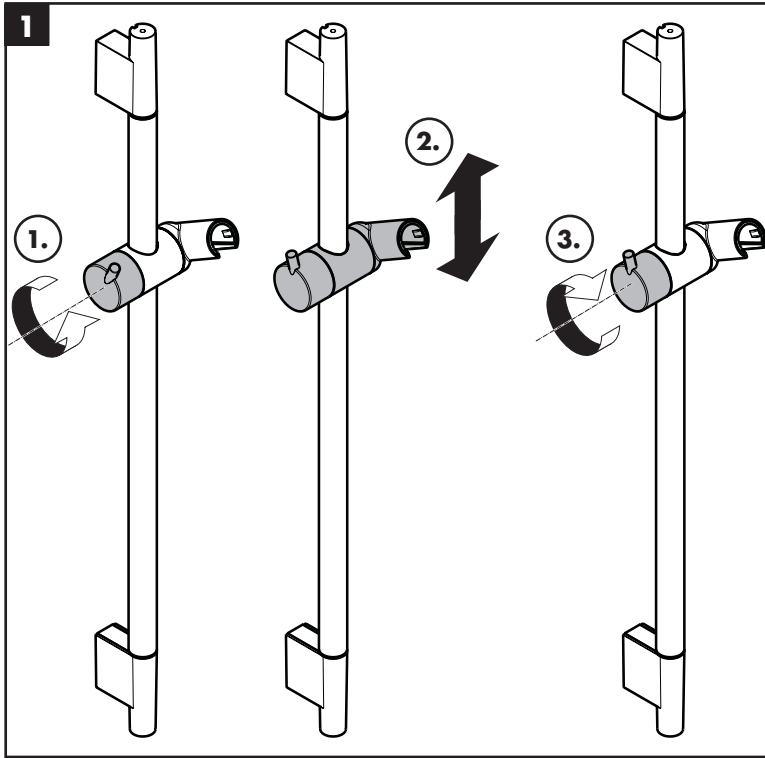



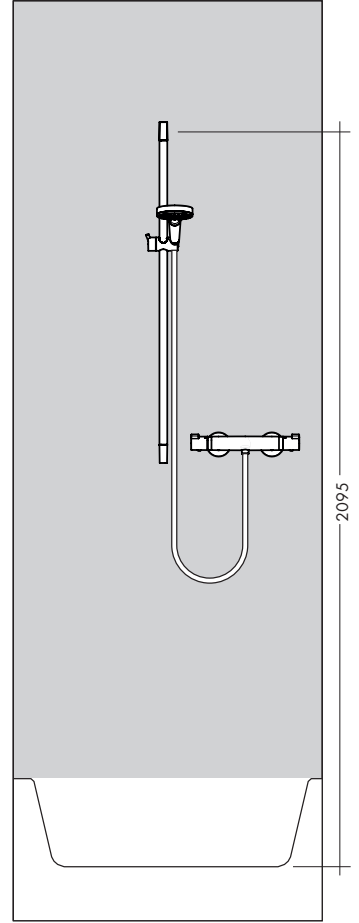
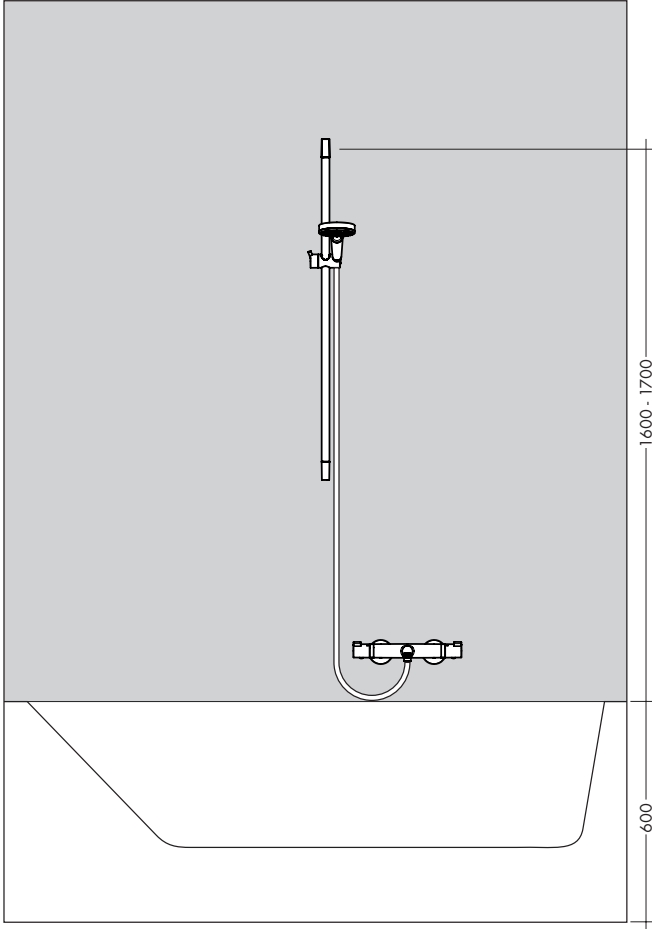

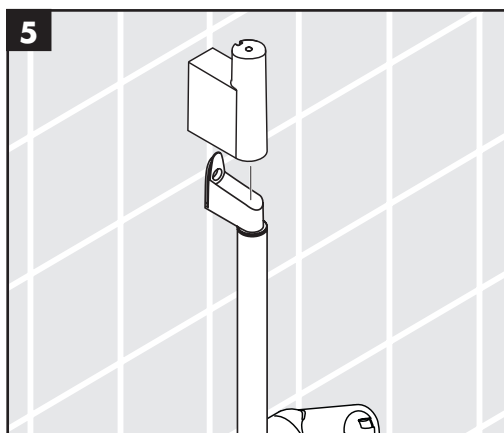
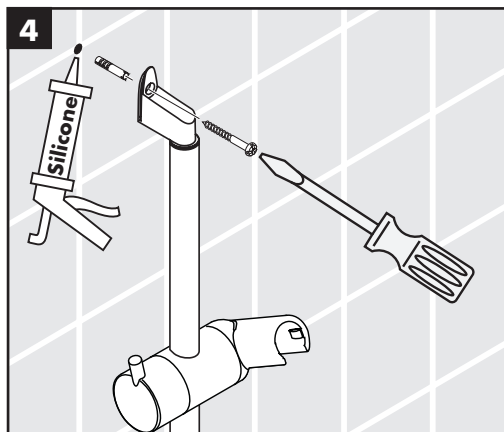
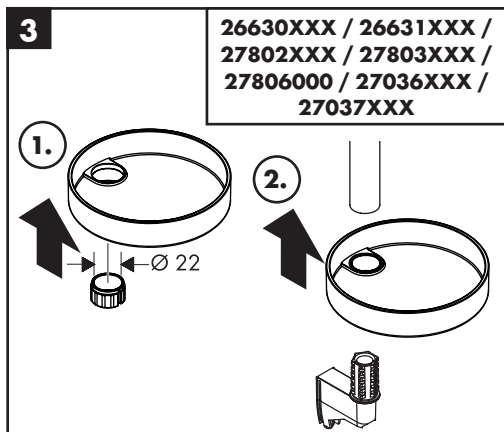
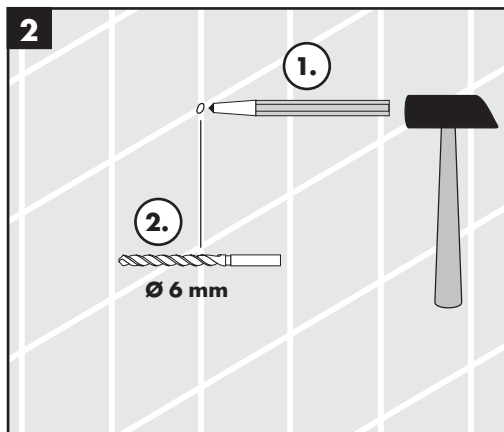
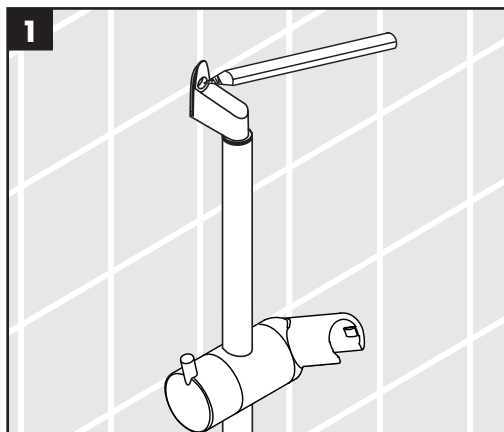



### Unica'S Puro

28632000

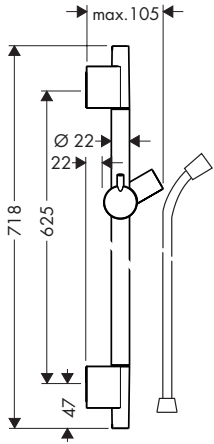

### Raindance Select 120 / Unica'S Puro Set

26620XXX

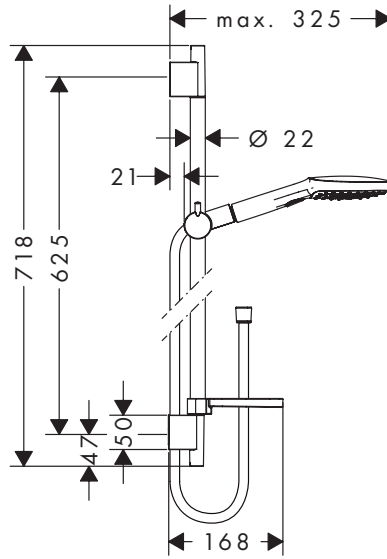

### Unica'S Puro

28631XXX

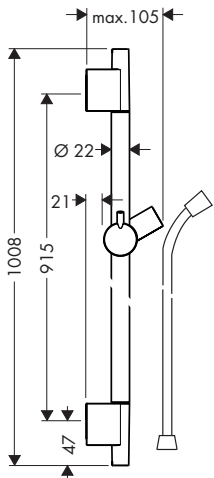

### Raindance Select 120 / Unica'S Puro Set

26621XXX

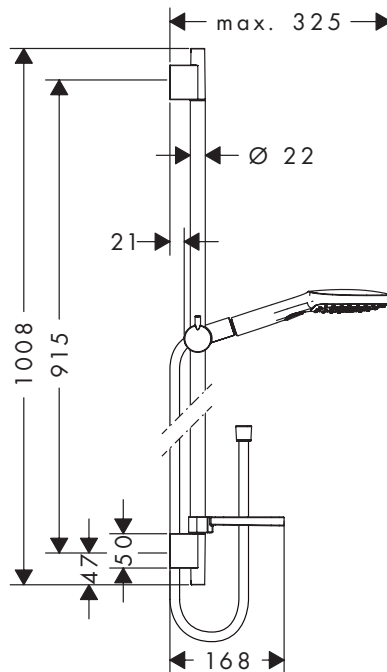

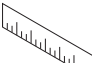

**Raindance Select S 120 / Unica'S Puro Set**  
26630XXX

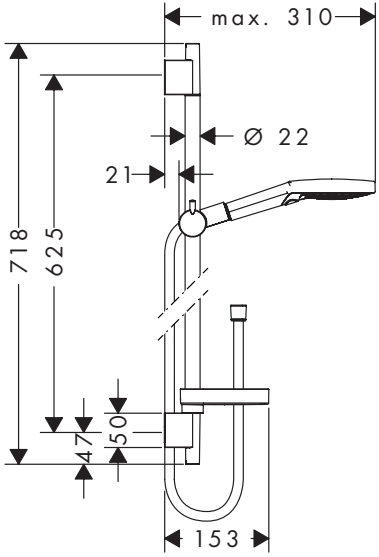

**Raindance Select E 150 / Unica'S Puro**  
27856XXX

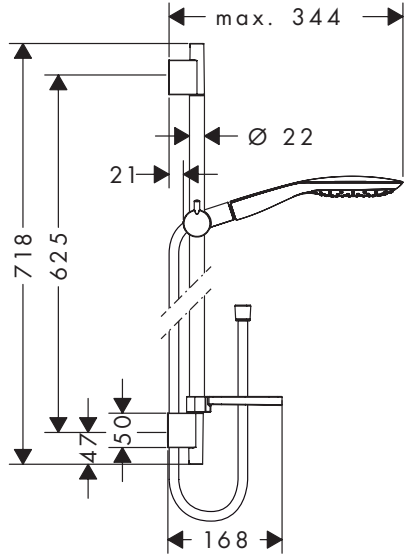

**Raindance Select S 120 / Unica'S Puro Set**  
26631XXX

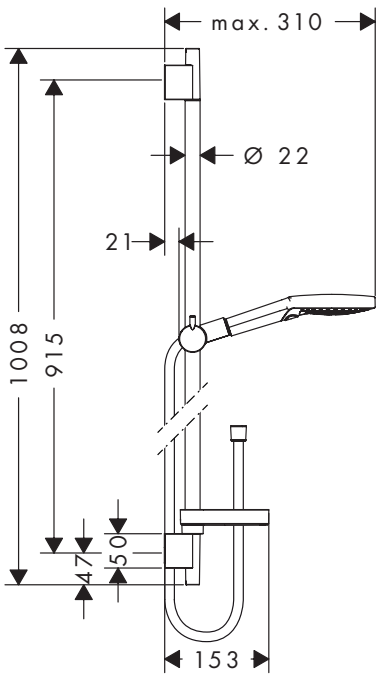

**Raindance Select E 150 / Unica'S Puro**  
27857XXX

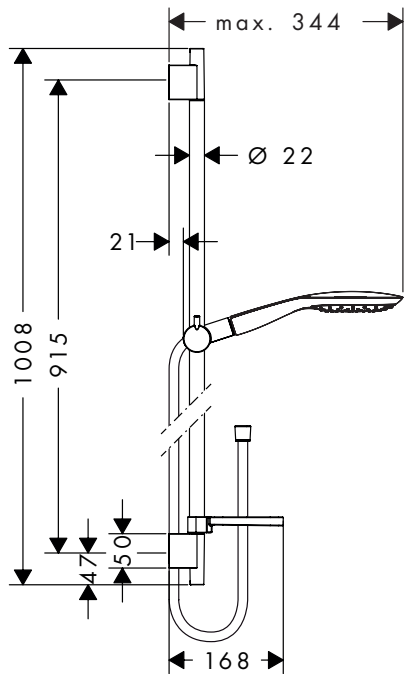



**Raindance Select S 150 / Unica'S Puro Set**  
27802XXX

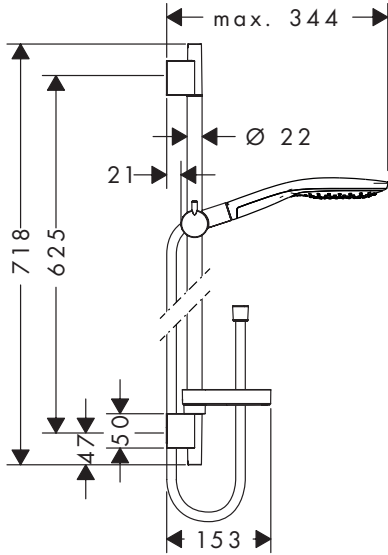

**Raindance Select 150 Combi**  
27036XXX

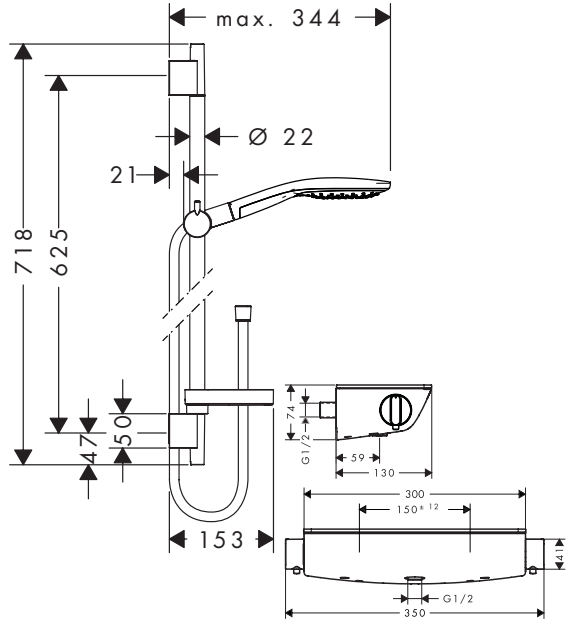

**Raindance Select S 150 / Unica'S Puro Set**  
27803XXX

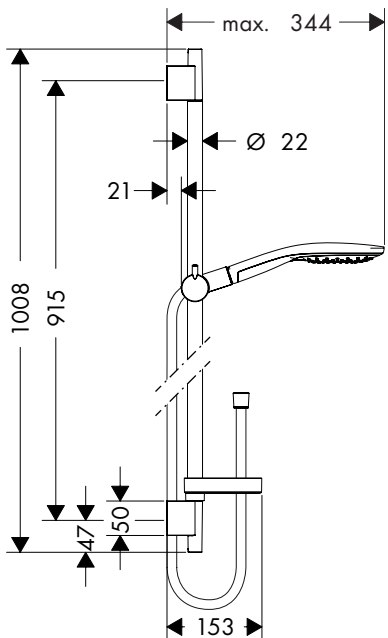

**Raindance Select 150 Combi**  
27037XXX

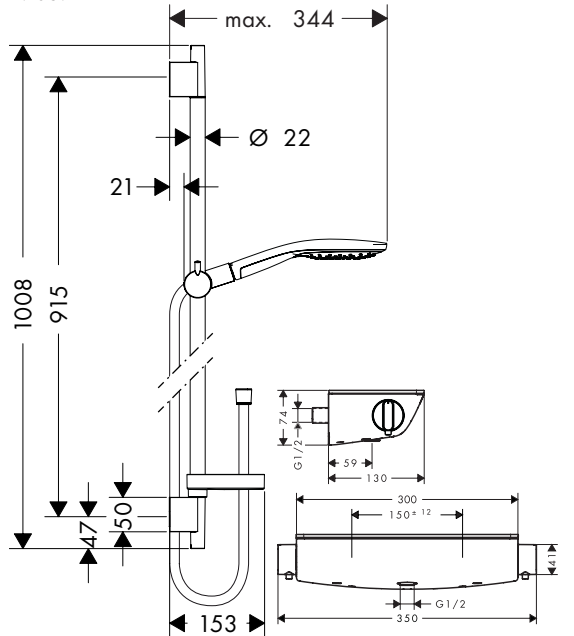



**ShowerTablet Select 300 Combi /  
Raindance Select E 120 3jet / Unica'S Puro**  
27026XXX

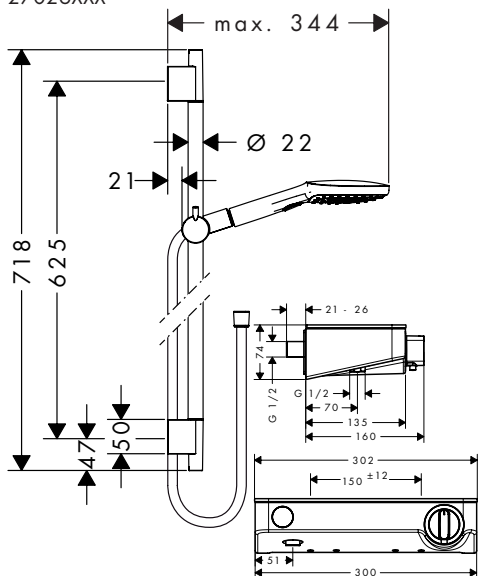

**Ecostat Select Combi / Raindance Select E 120 3jet**  
27038XXX

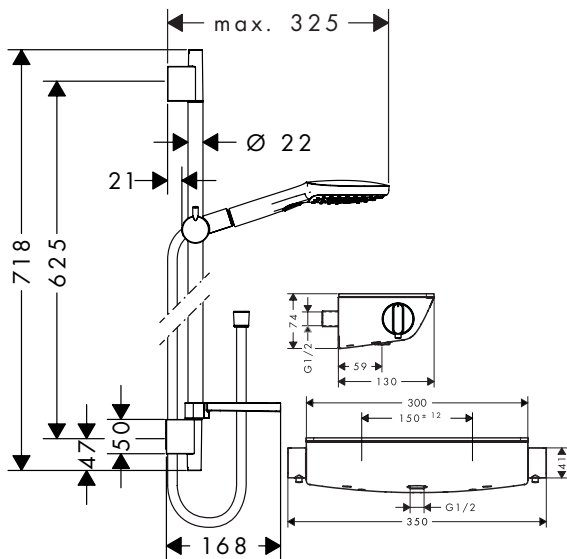

**ShowerTablet Select 300 Combi /  
Raindance Select E 120 3jet / Unica'S Puro**  
27027XXX

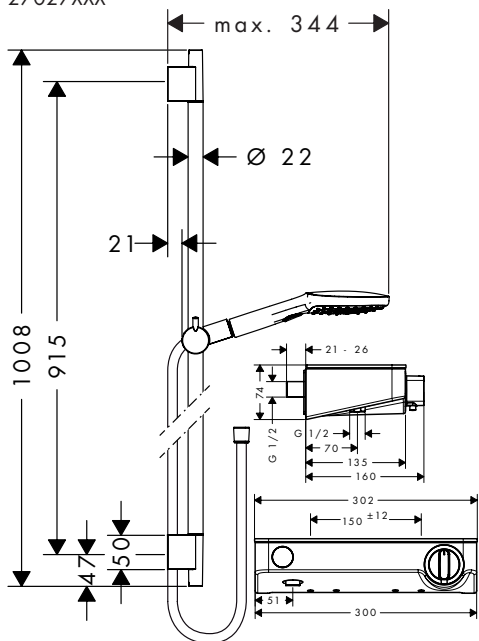

**Ecostat Select Combi / Raindance Select E 120 3jet**  
27039XXX

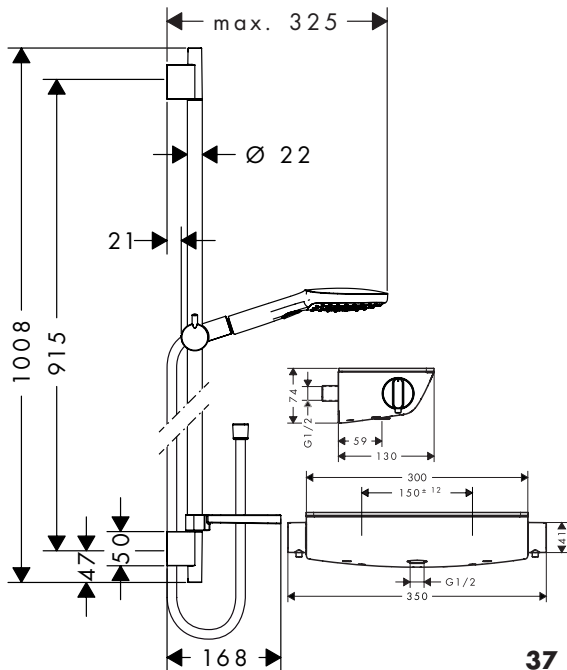

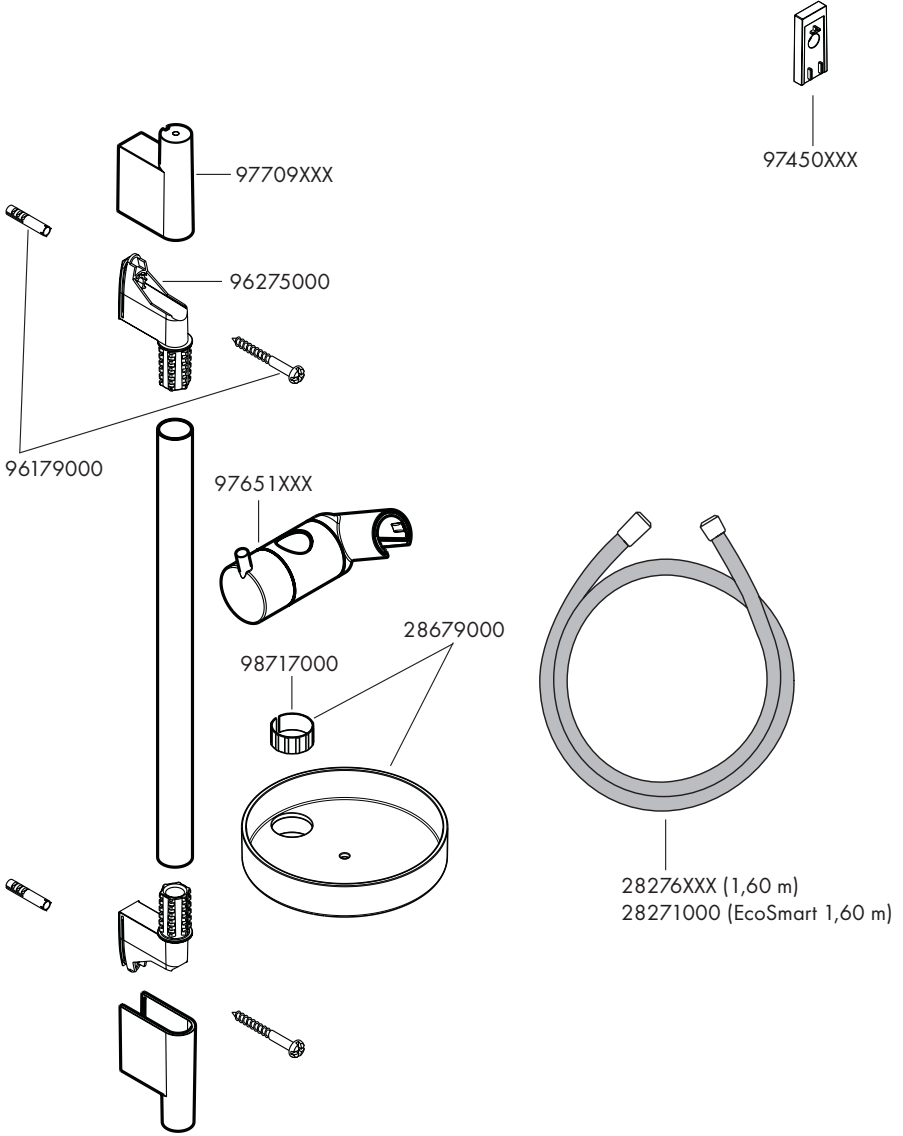







---

	<b>P-IX</b>	<b>DVGW</b>	<b>SVGW</b>	<b>WRAS</b>	<b>KIWA</b>	<b>NF</b>	<b>ACS</b>	<b>ETA</b>
<b>26620XXX</b>							X	
<b>26621XXX</b>							X	
<b>26630XXX</b>							X	
<b>26631XXX</b>							X	
<b>27026XXX</b>							X	
<b>27027XXX</b>							X	
<b>27036XXX</b>							X	
<b>27037XXX</b>							X	
<b>27038XXX</b>							X	
<b>27039XXX</b>						X	X	
<b>27802XXX</b>							X	
<b>27803XXX</b>							X	
<b>27856XXX</b>							X	
<b>27857XXX</b>							X	
<b>28631XXX</b>								
<b>28632XXX</b>								