

DE	Gebrauchsanleitung / Montageanleitung	2
FR	Mode d'emploi / Instructions de montage	4
EN	Instructions for use / assembly instructions	6
IT	Istruzioni per l'uso / Istruzioni per Installazione	8
ES	Modo de empleo / Instrucciones de montaje	10
NL	Gebruiksaanwijzing / Handleiding	12
DK	Brugsanvisning / Monteringsvejledning	14
RU	Руководство пользователя / Инструкция по монтажу	16

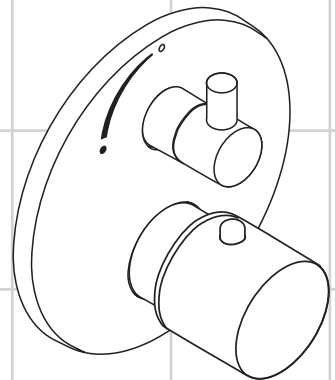

Mediano S
15731000



Ihr Online-Fachhändler für:

hansgrohe

- Kostenlose und individuelle Beratung
- Hochwertige Produkte
- Kostenloser und schneller Versand

- TOP Bewertungen
- Exzelerter Kundenservice
- Über 20 Jahre Erfahrung



E-Mail: info@unidomo.de | Tel.: 04621 - 30 60 89 0 | www.unidomo.de



Sicherheitshinweise

- ⚠ Bei der Montage müssen zur Vermeidung von Quetsch- und Schnittverletzungen Handschuhe getragen werden.
- ⚠ Kinder, sowie Erwachsene mit körperlichen, geistigen und / oder sensorischen Einschränkungen dürfen das Produkt nicht unbeaufsichtigt benutzen. Personen, die unter Alkohol- oder Drogeneinfluss stehen, dürfen das Produkt nicht benutzen.
- ⚠ Das Produkt darf nur zu Bade-, Hygiene- und Körperreinigungszwecken eingesetzt werden.
- ⚠ Große Druckunterschiede zwischen den Kalt- und Warmwasseranschlüssen müssen ausgeglichen werden.

Montagehinweise

- Vor der Montage muss das Produkt auf Transportschäden untersucht werden. Nach dem Einbau werden keine Transport- oder Oberflächenschäden anerkannt.
- Die Leitungen und die Armatur müssen nach den gültigen Normen montiert, gespült und geprüft werden.
- Die in den Ländern jeweils gültigen Installationsrichtlinien sind einzuhalten.

Technische Daten

Betriebsdruck:	max. 1 MPa
Empfohlener Betriebsdruck:	0,1 - 0,5 MPa
Prüfdruck:	1,6 MPa
(1 MPa = 10 bar = 147 PSI)	
Heißwassertemperatur:	max. 80 °C
Empfohlene Heißwassertemperatur:	65 °C
Thermische Desinfektion:	max. 70 °C / 4 min

Eigensicher gegen Rückfließen

Das Produkt ist ausschließlich für Trinkwasser konzipiert!

Symbolbeschreibung



Kein essigsäurehaltiges Silikon verwenden!

max. $\approx 42^{\circ}\text{C}$ **Safety Function** (siehe Seite 20)
 Dank der Safety Function lässt sich die gewünschte Höchsttemperatur von z. B. max. 42°C voreinstellen.



Einjustieren (siehe Seite 20)
 Nach erfolgter Montage muss die Auslauf-temperatur des Thermostaten überprüft werden. Eine Korrektur ist erforderlich wenn die an der Entnahmestelle gemessene Temperatur von der am Thermostaten eingestellten Temperatur abweicht.



Wartung (siehe Seite 22)
 Rückflussverhinderer müssen gemäß DIN EN 1717 regelmäßig in Übereinstimmung mit nationalen oder regionalen Bestimmungen (DIN 1988 einmal jährlich) auf ihre Funktion geprüft werden. Um die Leichtgängigkeit der Regeleinheit zu gewährleisten, sollte der Thermostat von Zeit zu Zeit auf ganz warm und ganz kalt gestellt werden.



Maße (siehe Seite 24)



Durchflussdiagramm
(siehe Seite 24)



Bedienung (siehe Seite 26)



Serviceteile (siehe Seite 25)



Reinigung
siehe beiliegende Broschüre.



Prüfzeichen (siehe Seite 24)







Störung	Ursache	Abhilfe
Wenig Wasser	- Versorgungsdruck nicht ausreichend - Schmutzfangsieb der Regeleinheit verschmutzt - Siebdichtung der Brause verschmutzt	- Leitungsdruck prüfen - Schmutzfangsiebe reinigen - Siebdichtung zwischen Brause und Schlauch reinigen
Kreuzfluss, warmes Wasser wird bei geschlossener Armatur in die Kaltwasserleitung gedrückt oder umgekehrt	- Rückflussverhinderer verschmutzt / defekt	- Rückflussverhinderer reinigen ggf. austauschen
Auslauftemperatur stimmt nicht mit der eingestellten Temperatur überein	- Thermostat wurde nicht justiert - Zu niedrige Warmwassertemperatur	- Thermostat justieren - Warmwassertemperatur erhöhen auf 42 °C bis 65 °C
Temperaturregelung nicht möglich	- Regeleinheit verkalkt - Bei Neuinstallation Grundkörper falsch angeschlossen (Soll: kalt rechts, warm links) oder 180° verdreht eingebaut	- Regeleinheit austauschen - Funktionsblock um 180° verdreht einbauen
Druckknopf der Sicherheitssperre ohne Funktion	- Feder defekt - Druckknopf verkalkt	- Feder bzw. Druckknopf reinigen u. leicht fetten, ggf. austauschen
Ventil schwergängig	- Absperrober teil beschädigt	- Absperreinheit austauschen
Brause oder Auslauf tropft	- Schmutz oder Ablagerungen auf dem Dichtsitz, Absperrober teil beschädigt	- Absperrober teil reinigen bzw. austauschen





Consignes de sécurité

-  Lors du montage, porter des gants de protection pour éviter toute blessure par écrasement ou coupure.
-  Il est interdit aux enfants ainsi qu'aux adultes ayant des insuffisances physiques, psychiques et/ou motoriques d'utiliser la douche sans surveillance. De même, il est interdit à des personnes sous influence d'alcool ou de drogues d'utiliser la douche.
-  Le système de douche ne doit servir qu'à se laver et à assurer l'hygiène corporelle.
-  Il est conseillé d'équilibrer les pressions de l'eau chaude et froide.

Instructions pour le montage

- Avant son montage, s'assurer que le produit n'a subi aucun dommage pendant le transport. Après le montage, tout dommage de transport ou de surface ne pourra pas être reconnu.
- Les conduites et la robinetterie doivent être montés, rincés et contrôlés selon les normes en vigueur.
- Les directives d'installation en vigueur dans le pays concerné doivent être respectées.

Informations techniques

Pression de service autorisée:	max. 1 MPa
Pression de service conseillée:	0,1 - 0,5 MPa
Pression maximum de contrôle:	1,6 MPa
(1 MPa = 10 bar = 147 PSI)	
Température d'eau chaude:	max. 80 °C
Température recommandée:	65 °C
Désinfection thermique:	max. 70 °C / 4 min

Avec dispositif anti-retour

Le produit est exclusivement conçu pour de l'eau potable!

Description du symbole



Ne pas utiliser de silicone contenant de l'acide acétique!

max. ≈ 42 °C **Safety Function** (voir pages 20)

Grâce à la fonction Safety, il est possible de prérégler la température maximale par exemple max. 42 °C souhaitée.



Réglage (voir pages 20)

Le montage terminé, contrôler la température de l'eau puisée au mitigeur thermostatique. Un étalonnage est nécessaire si la température de l'eau mitigée mesurée au point de puisage diffère sensiblement de celle affichée sur le thermostat.



Entretien (voir pages 22)

Les clapets anti-retour doivent être examinés régulièrement conformément à la norme EN 1717 ou conformément aux dispositions nationales ou régionales quant à leur fonction (au moins une fois par an). Pour assurer le mouvement facile de l'élément thermostatique, le thermostat devrait être placé de temps en temps en position très chaude et très froide.



Dimensions (voir pages 24)



Diagramme du débit

(voir pages 24)



Instructions de service (voir pages 26)



Pièces détachées (voir pages 25)



Nettoyage

voir la brochure ci-jointe.



Classification acoustique et débit (voir pages 24)



Dysfonctionnement	Origine	Solution
Pas assez d'eau	- Pression d'alimentation insuffisante	- Contrôler la pression
	- Filtre de l'élément thermostatique encrassé	- Nettoyer les filtres
	- Joint-filtre de douchette encrassé	- Nettoyer le joint-filtre entre la douchette et le flexible
Circulation opposée, l'eau chaude est comprimée dans l'arrivée d'eau froide et vice versa avec robinet fermé	- Clapet anti-retour encrassé ou défectueux	- Nettoyer le clapet anti-retour ou le changer éventuellement
La température à la sortie ne correspond pas à la température de réglage	- Le thermostat n'a pas été réglé	- Régler le thermostat
	- Température d'eau chaude trop basse, pas d'eau froide	- Augmenter la température d'eau chaude entre 42°C et 65°C
Le réglage de la température n'est pas possible	- Cartouche thermostatique entartrée	- Changer la cartouche thermostatique
	- La pièce de base a une alimentation inversée (l'eau froide doit être à droite et l'eau chaude à gauche) ou elle est montée à l'envers	- Montez le bloc de fonction à 180°
Bouton à pression du verrouillage de sécurité défectueux	- Ressort défectueux	- Nettoyer le ressort ou bien le bouton à pression, le changer éventuellement
	- Bouton à pression entartré	
Fonctionnement de la poignée difficile	- Mécanisme d'arrêt défectueux	- Changez le mécanisme d'arrêt
La douchette ou le bec verseur goutte	- De la saleté ou de l'incrustation sur le siège, mécanisme d'arrêt défectueux	- Nettoyez le mécanisme d'arrêt ou le changez éventuellement





Safety Notes

- △ Gloves should be worn during installation to prevent crushing and cutting injuries.
- △ Children as well as adults with physical, mental and/or sensoric impairments must not use this product without proper supervision. Persons under the influence of alcohol or drugs are prohibited from using this product.
- △ The shower system may only be used for bathing, hygienic and body cleaning purposes.
- △ The hot and cold supplies must be of equal pressures.

Installation Instructions

- Prior to installation, inspect the product for transport damages. After it has been installed, no transport or surface damage will be honoured.
- The pipes and the fixture must be installed, flushed and tested as per the applicable standards.
- The plumbing codes applicable in the respective countries must be observed.

Technical Data

Operating pressure:	max. 1 MPa
Recommended operating pressure:	0,1 - 0,5 MPa
Test pressure:	1,6 MPa
(1 MPa = 10 bar = 147 PSI)	
Hot water temperature:	max. 80°C
Recommended hot water temp.:	65°C
Thermal disinfection:	max. 70°C / 4 min

Safety against backflow

The product is exclusively designed for drinking water!

Special information for UK (see page 27)



Symbol description



Do not use silicone containing acetic acid!

max. $\approx 42^{\circ}\text{C}$ **Safety Function** (see page 20)
The desired maximum temperature for example max. 42°C can be pre-set thanks to the safety function.



Adjustment

 (see page 20)

After the installation, the output temperature of the thermostat must be checked. A correction is necessary if the temperature measured at the output differs from the temperature set on the thermostat.



Maintenance

 (see page 22)

The check valves must be checked regularly according to DIN EN 1717 in accordance with national or regional regulations (at least once a year). To guarantee the smooth running of the thermostat, it is necessary from time to time to turn the thermostat from total hot to total cold.



Dimensions

 (see page 24)

Flow diagram

(see page 24)



Operation

 (see page 26)

Spare parts

 (see page 25)

Cleaning

see enclosed brochure.



Test certificate

 (see page 24)







Fault	Cause	Remedy
Insufficient water	- Supply pressure inadequate	- Check water pressure (If a pump has been installed check to see if the pump is working).
	- Regulator filter dirty	- Clean filters
	- Shower filter seal dirty	- Clean filter seal between shower and hose
Crossflow, hot water being forced into cold water pipe, or vice versa, when mixer is closed	- Backflow preventers dirty or leaking	- Clean backflow preventers, exchange if necessary
Spout temperature does not correspond with temperature set	- Thermostat has not been adjusted	- Adjust thermostat
	- Hot water temperature too low	- Increase hot water temperature to 42 °C to 65 °C
Temperature regulation not possible	- thermo cartridge calcified	- Exchange thermo cartridge
	- For new installations: basic body incorrectly connected (should be: cold right, hot left) or installed with 180° rotation	- Install function block turned through 180°
Safety stop button not operating	- Spring defective	- Clean spring and/or button, exchange if necessary
	- Button calcified	
Valve stiff	- Shut-off unit damaged	- Exchange shut-off unit
Shower or spout dripping	- Dirt or sedimentation on valve seat, shut-off unit damaged	- Clean or exchange shut-off unit





Indicazioni sulla sicurezza

-  Durante il montaggio, per evitare ferite da schiacciamento e da taglio bisogna indossare guanti protettivi.
-  I bambini e gli adulti affetti da menomazioni fisiche, psichiche e/o sensoriali devono utilizzare il sistema doccia solo sotto sorveglianza. Il prodotto non deve essere utilizzato da persone sotto l'effetto di droghe o alcolici.
-  Il sistema doccia deve essere utilizzato esclusivamente per l'igiene del corpo.
-  Attenzione! Compensare le differenze di pressione tra i collegamenti dell'acqua fredda e dell'acqua calda.

Istruzioni per il montaggio

- Prima del montaggio è necessario controllare che non ci siano stati danni durante il trasporto. Una volta eseguito il montaggio, non verranno riconosciuti eventuali danni di trasporto o delle superfici.
- Montare, lavare e controllare tubature e rubinetteria rispettando le norme correnti.
- Vanno rispettate le direttive di installazione nazionali vigenti nel rispettivo paese.

Dati tecnici

Pressione d'uso:	max. 1 MPa
Pressione d'uso consigliata:	0,1 - 0,5 MPa
Pressione di prova:	1,6 MPa
(1 MPa = 10 bar = 147 PSI)	
Temperatura dell'acqua calda:	max. 80°C
Temp. dell'acqua calda consigliata:	65°C
Disinfezione termica:	max. 70°C / 4 min

Sicurezza antiriflusso

Il prodotto è concepito esclusivamente per acqua potabile!

Descrizione simbolo



Non utilizzare silicone contenente acido acetico!

max. Safety Function (vedi pagg. 20)
 ≈ 42°C Grazie alla funzione antiscottature Safety la temperatura massima per esempio max. 42°C desiderata è facilmente regolabile.



Taratura (vedi pagg. 20)
 Effettuata l'installazione del miscelatore termostatico bisogna controllare la temperatura di uscita. La taratura è necessaria quando la temperatura dell'acqua misurata sul punto di prelievo non corrisponde a quella fissata sul termostato.



Manutenzione (vedi pagg. 22)
 La valvola di non ritorno deve essere controllata regolarmente come da DIN EN 1717, secondo le normative nazionali e regionali (almeno una volta all'anno). Per garantire la scorrevolezza dell'elemento di regolazione, di tanto in tanto si dovrebbe regolare il termostatico passando da tutto caldo a tutto freddo.



Ingombri (vedi pagg. 24)



Diagramma flusso
 (vedi pagg. 24)



Procedura (vedi pagg. 26)



Parti di ricambio (vedi pagg. 25)



Pulitura
 vedi il prospetto accluso.



Segno di verifica (vedi pagg. 24)



Problema	Possibile causa	Rimedio
Scarsità d'acqua	- Pressione di erogazione insufficiente	- Provare la pressione di erogazione
	- Filtro dell'unità di regolazione sporco	- Pulire il filtro
	- Guarnizione del filtro della doccia sporca	- Pulire la guarnizione del filtro tra doccia e flessibile
Flusso incrociato; l'acqua calda viene spinta nella tubatura acqua fredda a rubinetteria chiusa o viceversa	- Antiriflusso sporco o non ermetico	- Pulire o sostituire l'antiriflusso
La temperatura di erogazione diversa da quella impostata	- Il termostatico non è stato regolato	- Regolare il termostatico
	- Temperatura dell'acqua calda	- Aumentare la temperatura acqua calda tra 42 °C e 65 °C
Impossibile la regolazione temperatura	- Unità di regolazione piena di calcare	- Sostituire l'unità di regolazione
	- In caso di nuova installazione - collegato male il termostatico (deve essere: acqua fredda a destra e calda a sinistra) o installato ruotato di 180°	- Ruotare di 180° l'unità di regolazione
Tasto antiscottatura non funzionante	- Molla difettosa - Tasto con depositi calcarei	- Pulire o sostituire la molla o il tasto
Rubinetto duro	- vitone di arresto danneggiato	- sostituire il vitone di arresto
Doccia / scarico gocciola	- Sporco o depositi nella sede della guarnizione, vitone di arresto danneggiato	- Pulire o sostituire il vitone di arresto





Indicaciones de seguridad

- ⚠ Durante el montaje deben utilizarse guantes para evitar heridas por aplastamiento o corte.
- ⚠ Niños, así como adultos con limitaciones corporales, mentales y/o sensoriales no deben utilizar el sistema de duchas sin vigilancia. Personas que se encuentran bajo el efecto de alcohol o drogas, no deben utilizar el sistema de duchas.
- ⚠ La grifería solo debe ser utilizada para fines de baño, higiene y limpieza corporal.
- ⚠ Grandes diferencias de presión en servicio entre agua fría y agua caliente deben equilibrarse.

Indicaciones para el montaje

- Antes del montaje se debe examinarse el producto contra daños de transporte. Después de la instalación so se reconoce ningún daño de transporte o de superficie.
- Los conductos y la grifería deben montarse, lavarse y comprobarse según las normas vigentes.
- Es obligatorio el cumplimiento de las directrices de instalación vigentes en el país respectivo.

Datos técnicos

Presión en servicio:	max. 1 MPa
Presión recomendada en servicio:	0,1 - 0,5 MPa
Presión de prueba:	1,6 MPa
(1 MPa = 10 bar = 147 PSI)	
Temperatura del agua caliente:	max. 80 °C
Temp. recomendada del agua caliente:	65 °C
Desinfección térmica:	max. 70 °C / 4 min

Seguro contra el retorno

El producto ha sido concebido exclusivamente para agua potable.

Descripción de símbolos



No utilizar silicona que contiene ácido acético!

max. $\approx 42^{\circ}\text{C}$ **Safety Function** (ver página 20)
Gracias al tope de temperatura se puede graduar la temperatura máxima por ejemplo max. 42° C.



Puesta a punto (ver página 20)
Después del montaje deberá comprobarse la temperatura del agua del termostato, en la salida del caño. Una corrección se efectuará siempre y cuando la temperatura del agua tomada a la salida del caño, no corresponda con la indicada en el volante del termostato.



Mantenimiento (ver página 22)
Las válvulas anti-retorno tienen que ser controladas regularmente según la norma DIN EN 1717, en acuerdo con las regulaciones nacionales o regionales (una vez al año, por lo menos). Para garantizar el funcionamiento duradero del termostato, el mando del mismo debería girarse de vez en cuando del extremo frío al extremo caliente.



Dimensiones (ver página 24)



Diagrama de circulación (ver página 24)



Manejo (ver página 26)



Repuestos (ver página 25)



Limpiar
ver el folleto adjunto.



Marca de verificación (ver página 24)



Problema	Causa	Solución
Sale poca agua	- presión insuficiente	- comprobar presión
	- filtro del termoelemento sucio	- limpiar filtro
	- Filtro de la teleducha sucio	- Limpiar / Cambiar filtro entre flexo y teleducha
Flujo de agua cruzada agua caliente entra en la tubería del agua fría o al revés	- válvula antirretorno sucia o pierde	- limpiar / cambiar válvula
Temperatura del agua no corresponde a lo marcado	- termostato no ha sido ajustado	- ajustar termostato
	- Temperatura del agua caliente demasiado baja	- aumentar temperatura del agua caliente a 42° - 65° C.
No es posible regular la temperatura	- Termoelemento calcificado o desgastado	- cambiar termoelemento
	- cuerpo empotrado mal montado (debe estar: frío = derecha) o instalado girado en 180°	- girar embellecedor en 180°
Botón de tope no funciona	- muelle defecto	- Limpiar y aplicar una fina capa de grasa en el muelle y el pulsador
	- botón lleno de cal	
Llave de paso va duro	- montura dañada	- cambiar montura
Pierde permanentemente agua por el caño	- Suciedad / Sedimentaciones en el asiento de la llave, o llave dañada	- Limpiar/Cambiar llave de paso





Veiligheidsinstructies

- ⚠ Bij de montage moeten ter voorkoming van kniel- en snijwonden handschoenen worden gedragen.
- ⚠ Kinderen en volwassenen met lichamelijke, geestelijke en/of sensorische beperkingen mogen het douchesysteem niet zonder toezicht gebruiken. Personen onder invloed van alcohol of drugs mogen het douchesysteem niet gebruiken.
- ⚠ Het douchesysteem mag alleen voor het wassen, hygiënische doeleinden en voor de lichaamreiniging worden gebruikt.
- ⚠ Grote drukverschillen tussen de koud- en warmwatertoevoer dienen vermeden te worden.

Montage-instructies

- Vóór de montage moet het product gecontroleerd worden op transportschade. Na de inbouw wordt geen transport- of oppervlakteschade meer aanvaard.
- De leidingen en armaturen moeten gemonteerd, gespoeld en gecontroleerd worden volgens de geldige normen.
- De in de overeenkomstige landen geldende installatierichtlijnen moeten nageleefd worden.

Technische gegevens

Werkdruk: max.	max. 1 MPa
Aanbevolen werkdruk:	0,1 - 0,5 MPa
Getest bij:	1,6 MPa
(1 MPa = 10 bar = 147 PSI)	
Temperatuur warm water:	max. 80 °C
Aanbevolen warm water temp.:	65 °C
Thermische desinfectie:	max. 70 °C / 4 min

Beveiligd tegen terugstromen

Het product is uitsluitend ontworpen voor drinkwater!

Symboolbeschrijving



Gebruik geen zuurhoudende silicone!

max. $\approx 42^{\circ}\text{C}$ **Safety Function** (zie blz. 20)
 Dankzij de Safety Function kan de gewenste maximale temperatuur van bijv. max. 42°C van te voren worden ingesteld.



Correctie (zie blz. 20)
 Na montage dient de uitstroomtemperatuur van de thermostaat gecontroleerd te worden. Een correctie is noodzakelijk als de aan het tappunt gemeten temperatuur afwijkt van de op de thermostaat ingestelde temperatuur.



Onderhoud (zie blz. 22)
 Keerklappen moeten volgens DIN EN 1717 regelmatig en volgens plaatselijk geldende eisen op het functioneren gecontroleerd worden. (Tenminste een keer per jaar). Om het soepel lopen van de regeleenheid te garanderen moet de thermostaat van tijd tot tijd op heel koud en heel warm worden ingesteld.



Maten (zie blz. 24)



Doorstroomdiagram
(zie blz. 24)



Bediening (zie blz. 26)



Service onderdelen (zie blz. 25)



Reinigen
zie bijgevoegde brochure.



Keurmerk (zie blz. 24)



Storing	Oorzaak	Oplossing
Weinig water	- Druk te laag - Vuilzeef van thermo-element verstopt - Zeefdichting handdouche verstopt	- Druk controleren - Vuilzeef reinigen - Zeefdichting handdouche reinigen
Kruisstroom, warm water stroomt in gesloten toestand in koud water leiding of omgekeerd	- Terugslagkleppen vervuild of defect	- Terugslagkleppen reinigen dan wel uitwisselen
Uitstroomtemperatuur komt niet met ingestelde temperatuur overeen	- Thermostaat niet ingesteld - Temperatuur van warm water te laag	- Thermostaat instellen - Warmwater toevoer verhogen min. 42°C naar 65°C
Temperatuur niet regelbaar	- regeleenheid verkalkt - Bij nieuwe installaties: basisgarnituur verkeerd aangesloten (moet zijn koud rechts en warm links) of 180° gedraaid gemonteerd	- regeleenheid uitwisselen - Functieblok 180° draaien
Safety Stop knop op thermostaat-greep functioneert niet	- Veer defect - Drukknop verkalkt	- Veer en/of drukknop reinigen dan wel uitwisselen
Kraan draait zwaar	- bovendeeel beschadigd	- Bovendeeel uitwisselen
Douche/uitloop lekt	- Vuil of verkalking op de zitting, bovendeeel beschadigd	- Bovendeeel reinigen of omstelling uitwisselen





Sikkerhedsanvisninger

- △ Ved monteringen skal der bruges handsker for at undgå kvæstelser og snitsår.
- △ Børn som også voksne med fysiske, mentale og / eller sensoriske begrænsninger må ikke bruge brusersystemet uden opsyn. Personer som er under indflydelse af alkohol eller narkotika må ikke bruge brusersystemet.
- △ Brusersystemet må kun bruges til bade-, hygiejne og rengøringsformål.
- △ Større trykforskelle mellem koldt og varmt vand bør udjævnes.

Monteringsanvisninger

- Før monteringen skal produktet kontrolleres for transportskader. Efter monteringen godkendes transportskader eller skader på overfladen ikke længere.
- Ledningerne og armaturerne skal monteres, skylles og kontrolleres iht. de gældende standarder.
- Installationsbestemmelserne, der gælder i det enkelte land, skal overholdes.

Tekniske data

Driftstryk:	max. 1 MPa
Anbefalet driftstryk:	0,1 - 0,5 MPa
Prøvetryk:	1,6 MPa
(1 MPa = 10 bar = 147 PSI)	
Varmtvandstemperatur:	max. 80 °C
Anbefalet varmtvandsstemperatur:	65 °C
Termisk desinfektion:	max. 70 °C / 4 min

Med indbygget kontraventil

Produktet er udelukkende beregnet til drikkevand!

Symbolbeskrivelse



Der må ikke benyttes eddikesyreholdig silikone!

max.
≈ 42 °C

Safety Function (se s. 20)

Takket være Safety varmtvands-begrænsningen kan maksimaltemperaturen forudindstilles eksempel max. 42 °C.



Justering (se s. 20)

Efter monteringen skal termostatsens udløbstemperatur kontrolleres. Såfremt den målte vandtemperatur afviger fra den på termostaten viste forindstilling er en korrigering af skalagrebet nødvendig.



Service (se s. 22)

Ifølge DIN EN 1717 skal gennemstrømningsbegrænsere i overensstemmelse med nationale regler afprøves regelmæssigt (mindst en gang om året). For at sikre optimal funktion af termostaten, bør termostaten fra tid til anden motioneres (stilles skiftevis helt varm og helt kold).



Målene (se s. 24)



Gennemstrømningsdiagram

(se s. 24)



Brugsanvisning (se s. 26)



Reservedele (se s. 25)



Rengøring

se venligst den vedlagte brochure.



Godkendelse (se s. 24)



Fejl	Årsag	Hjælp
For lidt vand	<ul style="list-style-type: none"> - Forsyningsstrykket er ikke højt nok - Smudsfangsien er snavset - Sien mellem bruser og slange er snavset 	<ul style="list-style-type: none"> - Afprøv forsyningsstrykket - Rengør smudsfangsien - Rengør sien mellem bruser og slange
Kryds-flow, varmt vand i koldtvalsledningen og omvendt	<ul style="list-style-type: none"> - Kontraventilen er snavset eller utæt. 	<ul style="list-style-type: none"> - Rengør kontraventilen eller udskift den evt.
Udløbstemperaturen stemmer ikke overens med den indstillede temperatur	<ul style="list-style-type: none"> - Termostaten er ikke justeret - For lav varmtvands-temperatur 	<ul style="list-style-type: none"> - Juster termostaten! - Forhøj varmtvands-temperaturen fra 42°C til 65°C
Temperaturregulering ikke mulig	<ul style="list-style-type: none"> - katuschen er tilkalket - Ved ny-installation er vandtilslutningen forbyttet (skal være koldt til højre - varmt til venstre eller også er grundkroppen drejet 180°) 	<ul style="list-style-type: none"> - Udskift katuschen - Vend indbygningsdelen 180°
Sikkerhedsspærren er ude af funktion	<ul style="list-style-type: none"> - Defekt fjeder - Trykknappen tilkalket 	<ul style="list-style-type: none"> - Rengør fjeder og tryknap eller udskift delene
Ventilen går trægt	<ul style="list-style-type: none"> - Beskadiget afspærrings-ventil 	<ul style="list-style-type: none"> - Udskift afspærringsventilen
Bruser/kartud drypper	<ul style="list-style-type: none"> - Snavs eller kalk på pakningen, beskadiget afspærringsventil 	<ul style="list-style-type: none"> - Rengør afspærrings-ventil eller udskift evt.





Указания по технике безопасности

- △ Во время монтажа следует надеть перчатки во избежание прищемления и порезов.
- △ Дети, а также взрослые с физическими, умственными и/или сенсорными недостатками должны пользоваться изделием только под присмотром. Запрещается пользоваться изделием в состоянии алкогольного или наркотического опьянения.
- △ Изделие разрешается использовать только в гигиенических целях: для принятия ванны и личной гигиены.
- △ донного клапа. Перед установкой смесителя необходимо регулировочными кранами выровнять давление холодной и горячей воды при помощи вентилей регулирующих подачу воды в квартиру.

Указания по монтажу

- Перед монтажом следует проверить изделие на предмет повреждений при перевозке. После монтажа претензии о возмещении ущерба за повреждения при перевозке или повреждения поверхностей не принимаются.
- Трубы и арматура должны быть установлены, промыты и проверены в соответствии с действующими нормами.
- Необходимо соблюдать требования по монтажу, действующие в соответствующих странах.

Технические данные

Рабочее давление:	не более. 1 МПа
Рекомендуемое рабочее давление:	0,1 - 0,5 МПа
Давление:	1,6 МПа
(1 МПа = 10 bar = 147 PSI)	
Температура горячей воды:	не более. 80 °С
Рекомендуемая темп. гор. воды:	65 °С
Термическая дезинфекция:	не более. 70 °С / 4 мин

укомплектован клапаном обратного тока воды

Изделие предназначено исключительно для питьевой воды!

Описание символов



Не применяйте силикон, содержащий искусственную кислоту.

max. $\approx 42^{\circ}\text{C}$ **Safety Function** (см. стр. 20)
С помощью функции Safety Function может быть задана максимальная температура воды, например 42°C .



Настройка (см. стр. 20)

После монтажа следует проверить температуру на выходе из термостата. Скорректируйте температуру воды, если она отличается от установленной на термостате.



Техническое обслуживание (см. стр. 22)

Защита обратного тока должна регулярно проверяться (минимум один раз в год) по стандарту DIN EN 1717 или в соответствии с национальными или региональными нормативами. Для гарантии плавного изменения температуры и долгого срока службы необходимо периодически поворачивать ручку регулировки температуры из положение максимально горячая в положение максимально холодная вода.



Размеры (см. стр. 24)



Схема потока (см. стр. 24)



Эксплуатация (см. стр. 26)



Комплект (см. стр. 25)



Очистка

см прилагаемая брошюра



Знак технического контроля (см. стр. 24)



Неисправность	Причина	Устранение неисправности
недостаточный давление (если устан напор воды)	- Проблемы водоснабжения	- Проверить овлен насос проверить работу насоса
	- Фильтр термoeлементa загрязнен	- Очистить фильтр
	- Фильтр душа загрязнен	- Очистить фильтр
Подмес воды, в закрытом положении горячая вода стремится в подводку холодной воды или наоборот	- Клапан обратного тока воды загрязнен или неисправен	- Очистить кланан или заменить при необходимости
Температура смешанной воды не соответствует шкале	- Термостат не настроен	- Настроить термостат
	- Температура горячей воды слишком низкая	- Поднять температуру горячей воды с 42 град.С до 65 град.С
Регулировка температура не производится	- Регулятор засорен накипью	- Замените регулятор
	- для вновь установленного изделия: ошибка установки, холод ная вода подводится справа горячая слева, или установлено с 180 град поворотом.	- повернуть внутренний блок
Красная кнопка защиты от ожога не работает	- Износ пружины кнопки	- Очистите пружину или кнопку и слегка смажьте, при необходимости замените
	- Заизвесткованность кнопки	
Вентиль заедает	- Верхняя часть отключающего устройства повреждена	- Замените верхнюю часть отключающего устройства
Из душа или выхода капает вода	- Загрязнения или отложения на уплотнительном кольце, верхняя часть запора повреждена	- Очистите или замените верхнюю часть отключающего устройства



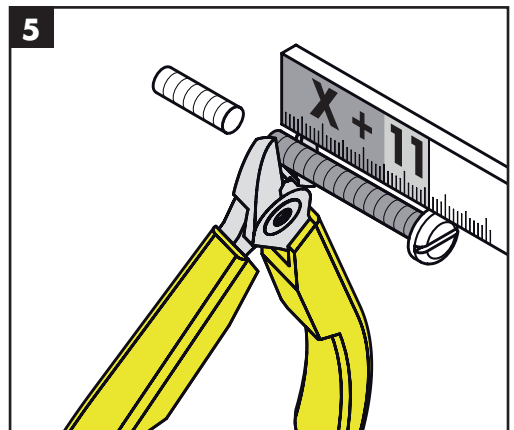
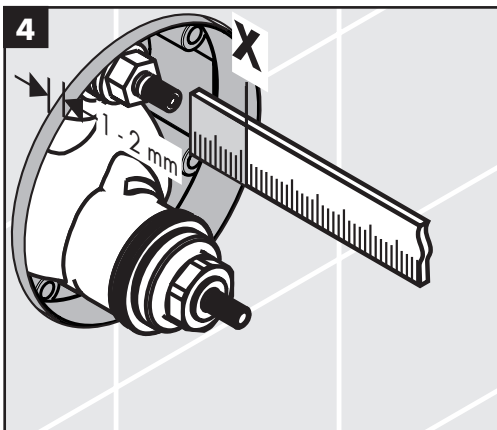
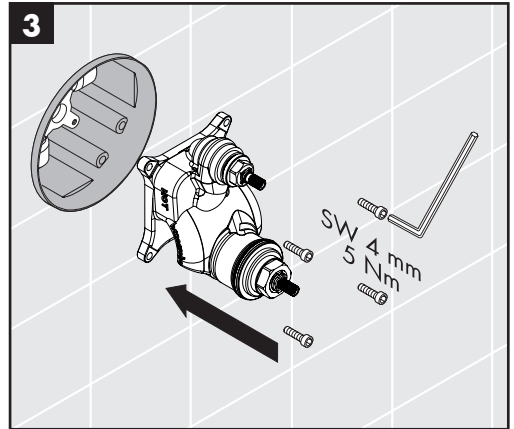
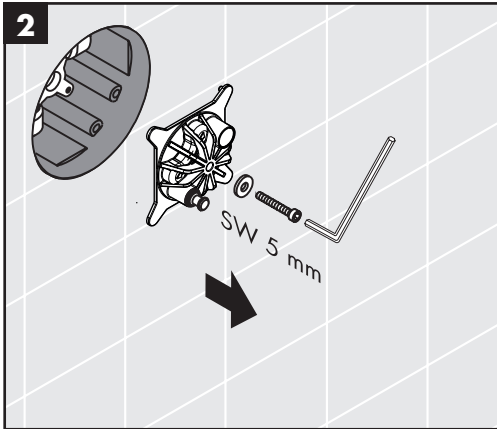
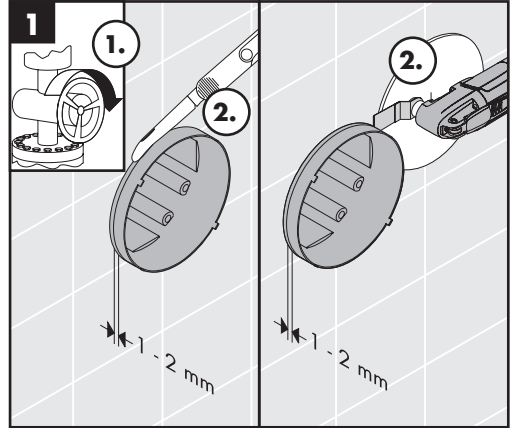
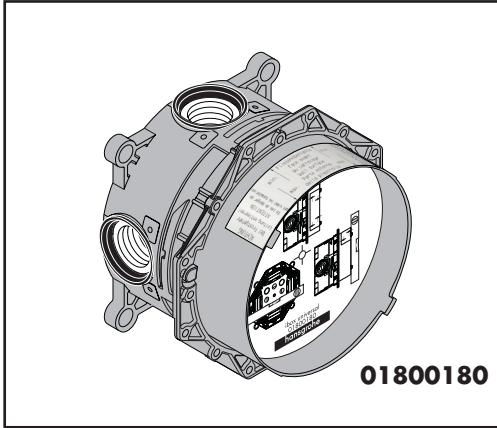

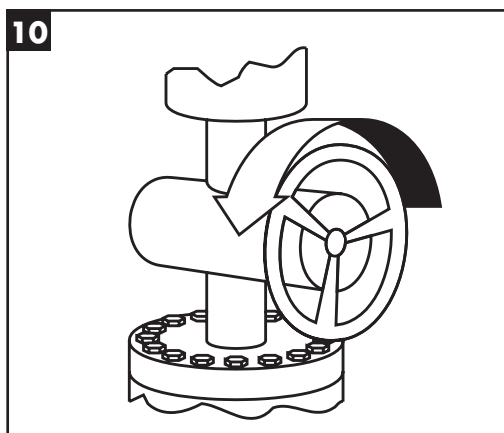
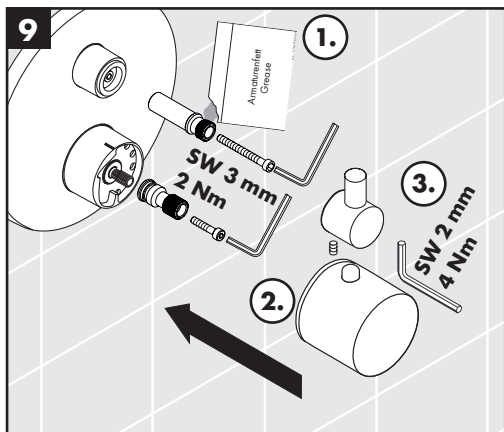
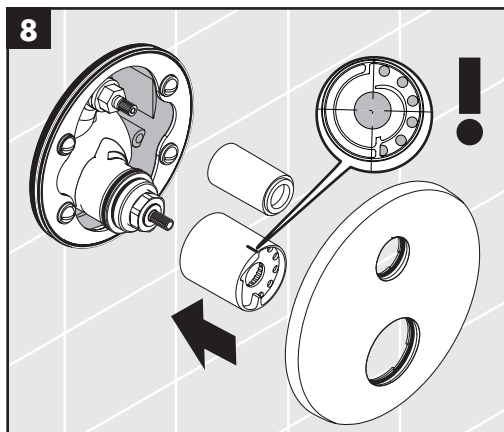
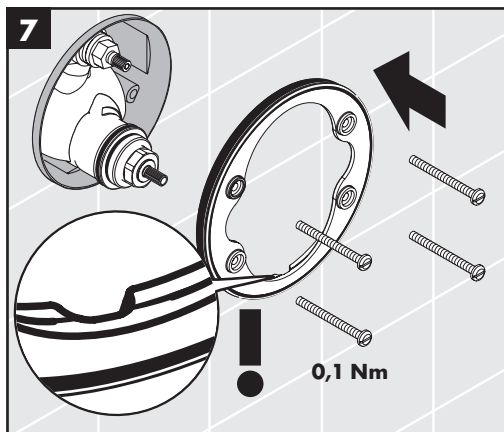
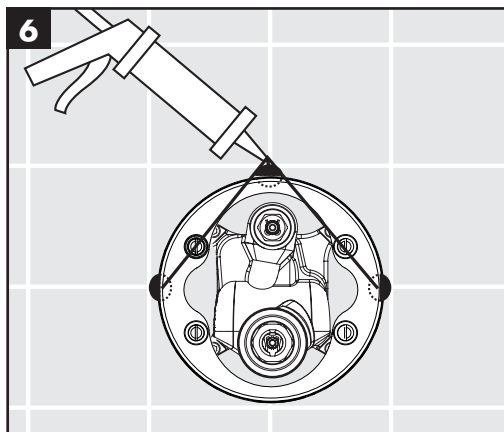

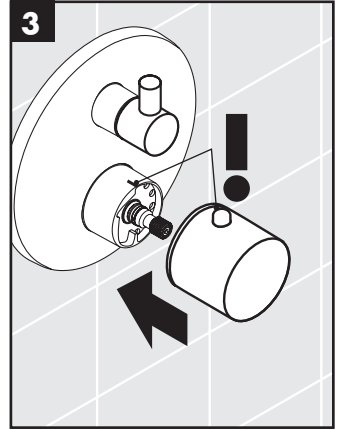
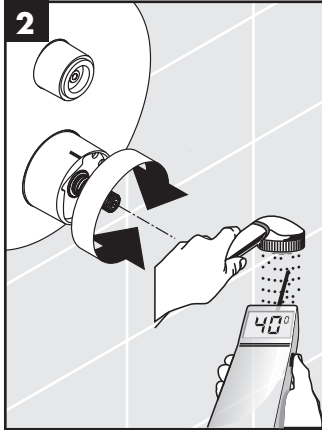
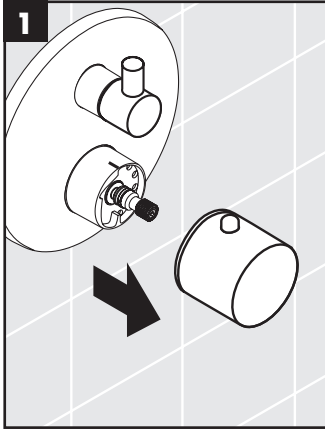

max.
≈ 42 °C

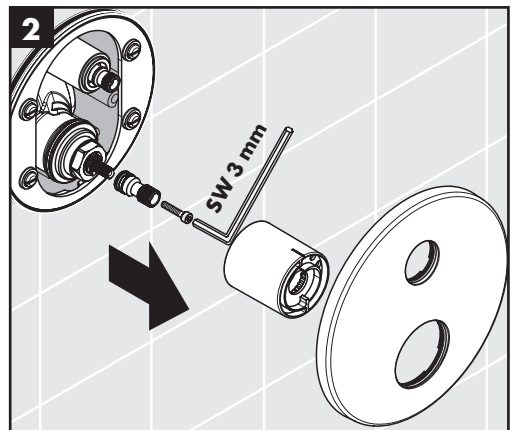
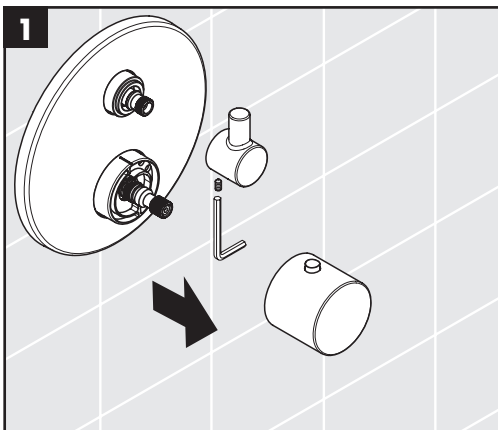

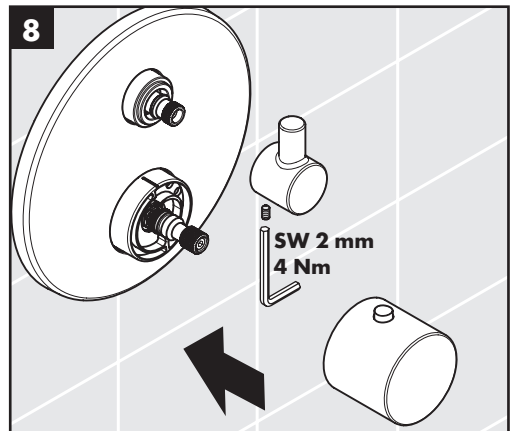
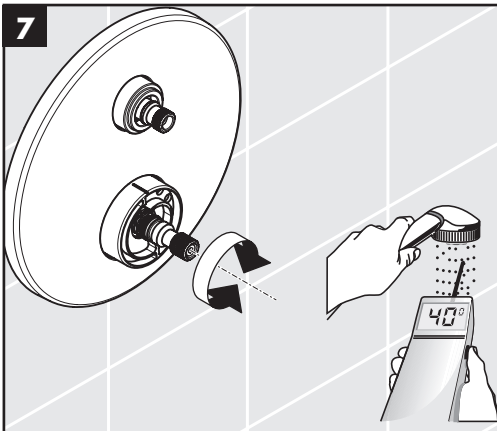
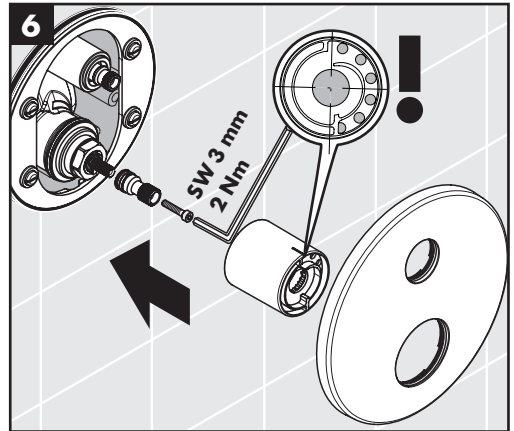
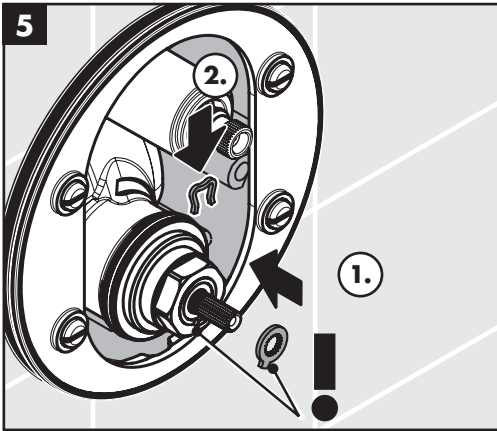
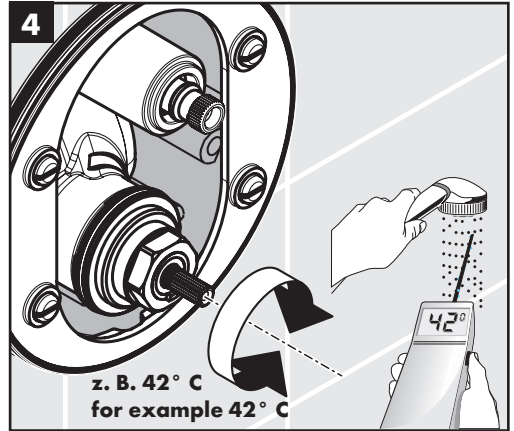
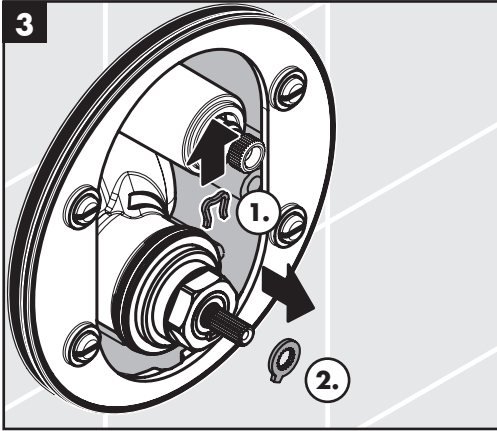

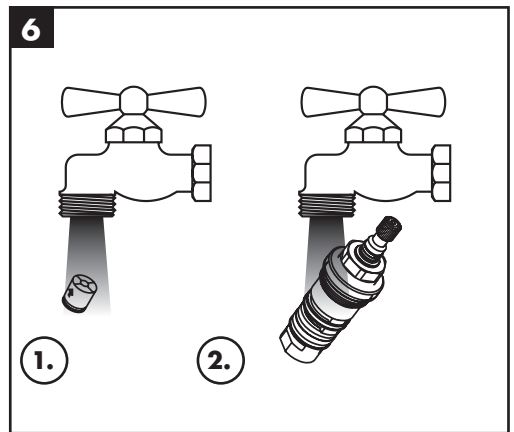
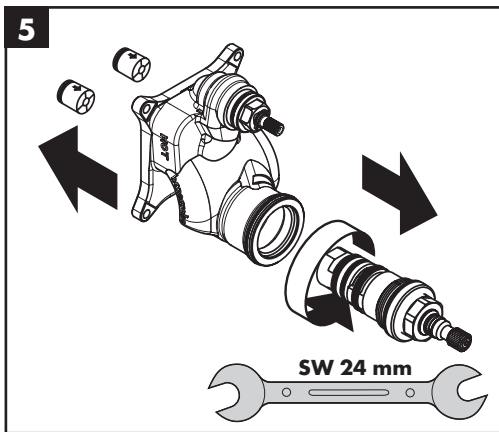
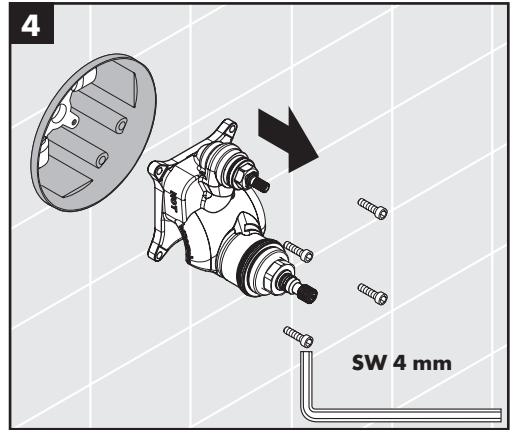
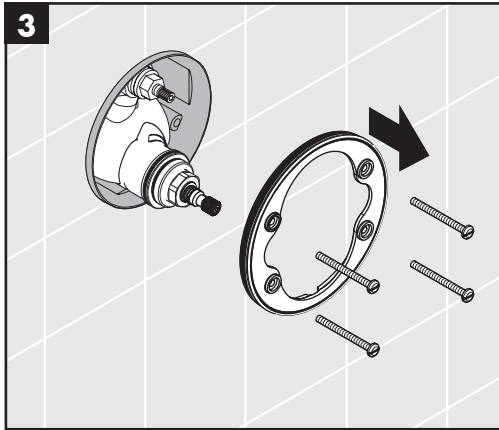
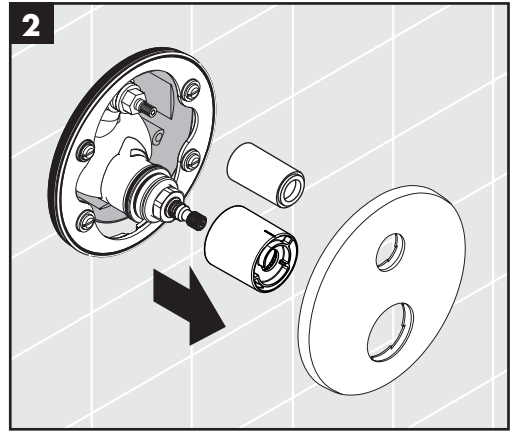
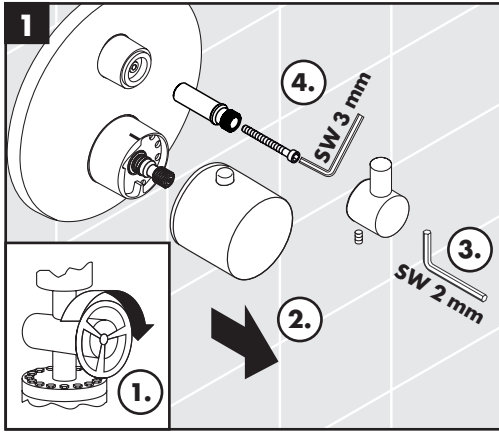

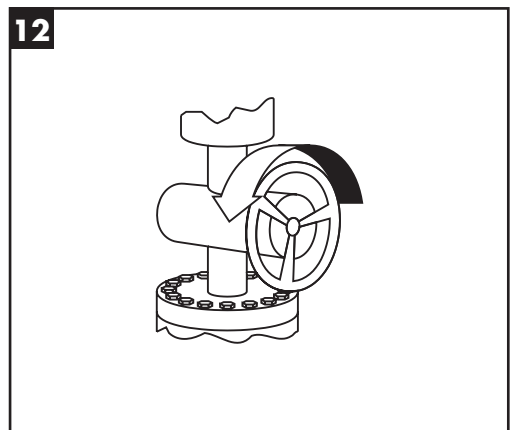
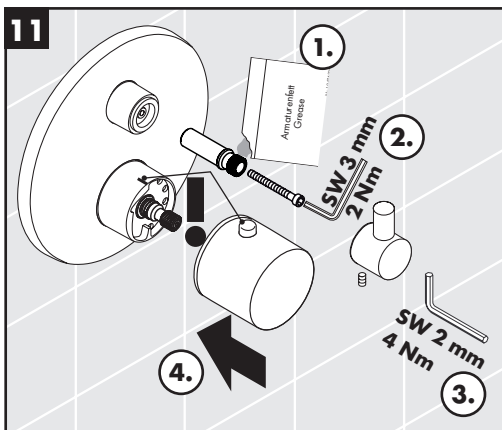
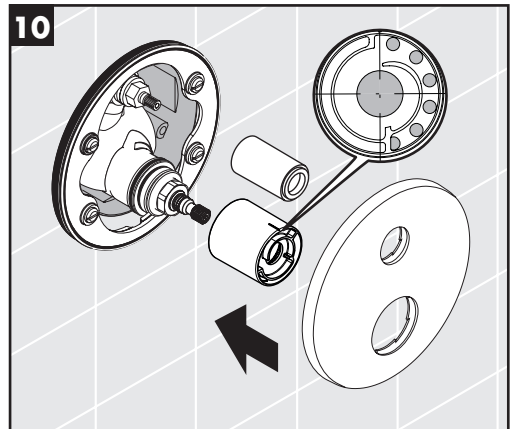
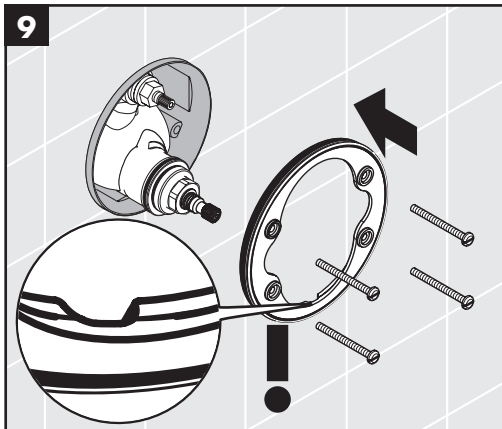
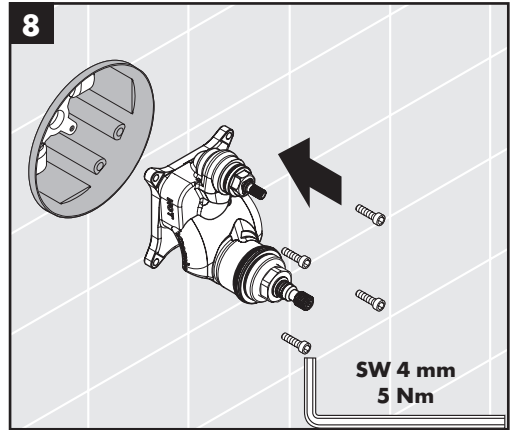
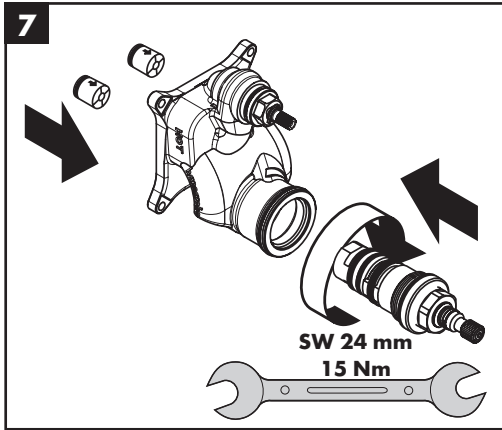

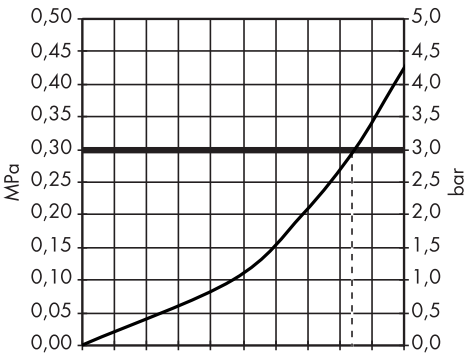
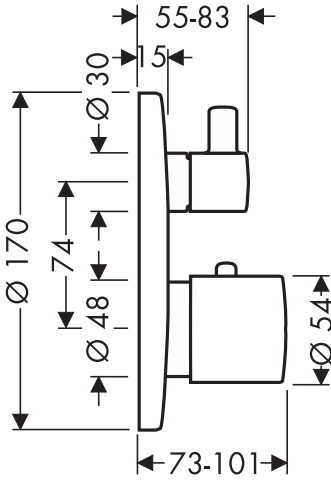

Q = l/min 0 3 6 9 12 15 18 21 24 27 30
 Q = l/sec 0 0,1 0,2 0,3 0,4 0,5



	P-IX	DVGW	MCA	SVGW	WRAS	KIWA	NF	ACS
15731000	PA-IX 9711/ID		X	X	X	X		X



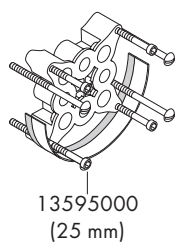
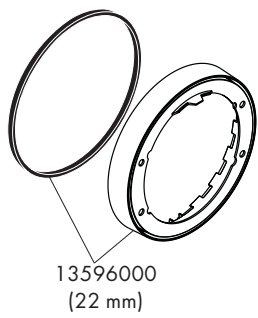
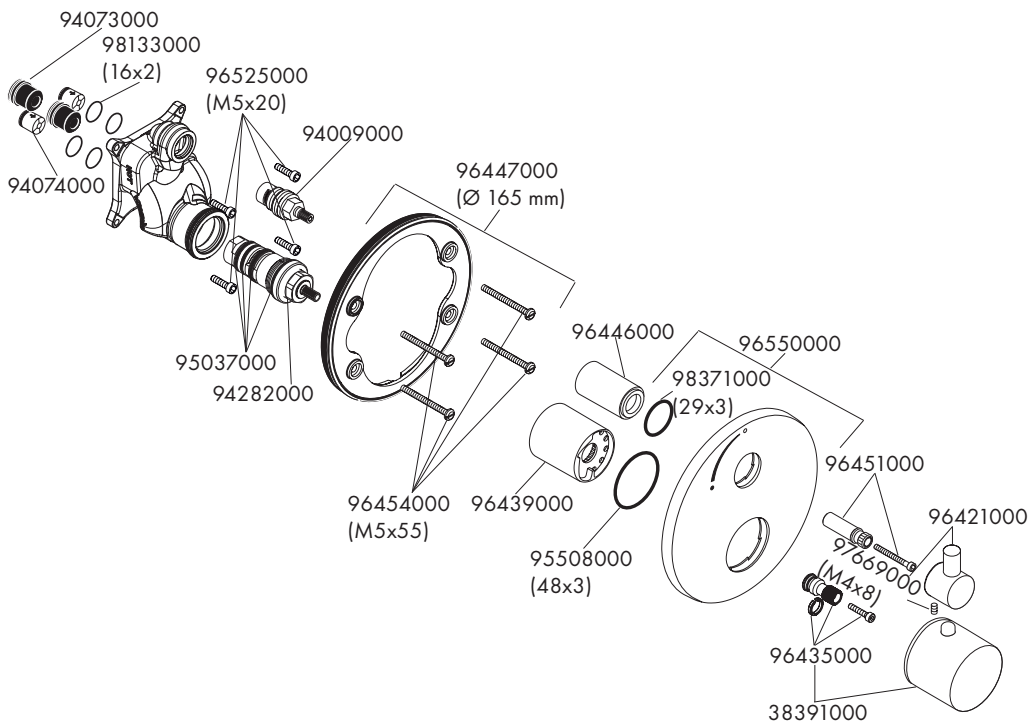

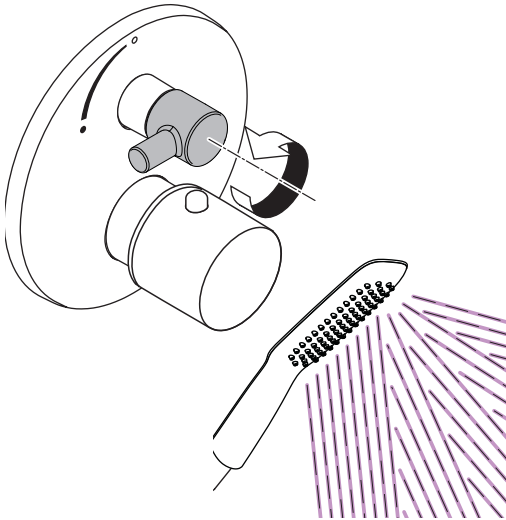

öffnen / ouvert / open / aperto / abierto / open / åbne /
открыть

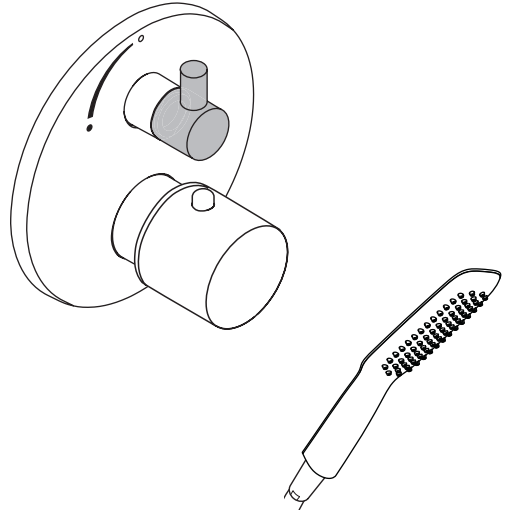

schließen / fermé / close / chiudere / cerrar / sluiten /
lukke / закрыть

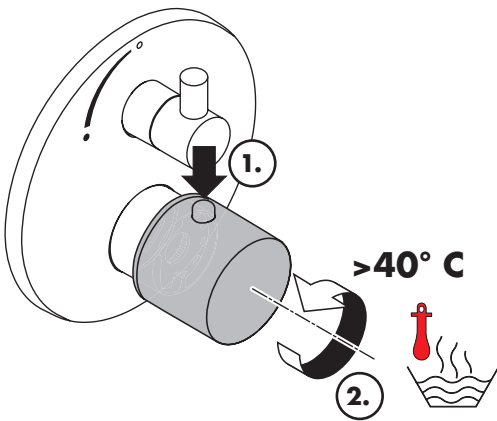

warm / chaud / hot / caldo / caliente / warm / varmt /
горячая

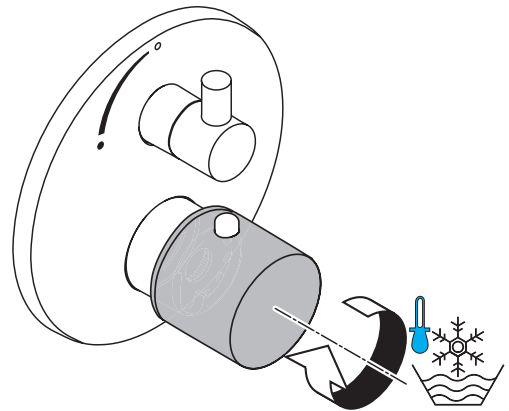

kalt / froid / cold / freddo / frío / koud / koldt /
холодная



On the following pages 27 - 32 you can find important information only for the installation in UK

Safety and Important Information

Hansgrohe products are safe provided they are installed, used and maintained in accordance with these instructions and recommendations.

Please read these instructions thoroughly and retain for future use.

The plumbing installation of this thermostat mixing valve must comply with the requirements of UK Water Regulations/Bylaws (Scotland), Building Regulations or any other regulations specified by the local Water Authority and supplier.

The installation of thermostatic mixing valves must comply with the requirements of the Water Supply (Water Fittings) Regulations 1999.

We strongly recommend that you use a plumber registered with or a member of an Association:

Chartered Institute of Plumbing and Heating Engineering (CIPHE)
Water Industry Approved Plumber Scheme (WIAPS)

Dispose of plastic bags carefully

Keep children well away from the work area.

Check for hidden pipes and cables in the wall before drilling holes.

The unit must be mounted on a finished waterproofed wall surface (usually tiles).

If you are using power tools (e.g. to drill holes) wear safety glasses and always disconnect tools from the power supply after use.

Do not operate the shower unit if the hand shower or spray hose has been damaged or is blocked.

Do not block the flow of water from the hand shower, by placing it on your hand or any other part of your body or foreign object.

The thermostatic unit should be serviced annually by a qualified person to ensure maximum safety during use.

The mixer is fitted with check valves (page 25 pos. 94074000). There are filters on the thermostatic element too (page 25 pos. 94282000).

The fitting of isolation valves is required (preferred location page 29 Installation Requirements)

Technical Hotline for UK only 0 870 7701975

E-mail for UK only Technical@hansgrohe.co.uk

(Diese Servicehotline ist nur für das Vereinigte Königreich Großbritannien, nicht z. B. für Deutschland)

Technical Data

This thermostatic valve will suit supplies of:
HIGH PRESSURE (HP-S)

Operating pressure:	max. 10 bar
Recommended operating pressure:	1 - 5 bar
Test pressure:	16 bar
Hot water temperature:	max. 80 °C
Recommended hot water temp.:	65 °C
Rate of flow:	36 l/min. @ 3 bar
Maximum outlet temperature:	43 °C +/-*
Safety check:	40 °C
Hot water connection:	Left hand
Cold water connection:	Right hand
Minimum difference between hot water and mixed water temperature:	6 K
Hot and cold supply pressure should be balanced	

Mixed water temperature

Application	Mixed water temperature (at point of discharge).
Shower	41 °C max.
Washbasin	41 °C max.
Bath (44 °C fill)	44 °C max.
Bath (46 °C fill)	46 °C max.

* For preset outlet temperature adjustment – See page 20.
NB. If a water supply is fed by gravity then the supply pressure should be verified to ensure the conditions of use are appropriate for the valve. Valves operating outside of these supply conditions cannot be guaranteed to operate as a TMV2 or TMV3 valve.

Recommended outlet temperatures

The BuildCert TMV scheme recommends the following set maximum mixed water outlet temperatures for use in all premises:

- 44 °C for bath fill but see notes below;
- 41 °C for showers;
- 41 °C for washbasins.

The mixed water temperatures must never exceed 46 °C. The maximum mixed water temperature can be 2 °C above the recommended maximum set outlet temperatures.

Note: 46 °C is the maximum mixed water temperature from the bath tap. The maximum temperature takes account of the allowable temperature tolerances inherent in thermostatic mixing valves and temperature losses in metal baths. It is not a safe bathing temperature for adults or children. The British Burns Association recommends 37 to 37.5 °C as a comfortable bathing temperature for children. In premises covered by the Care Standards Act 2000, the maximum mixed water outlet temperature is 43 °C

Supply Conditions TMV2

Operating pressure range	High pressure
Maximum static pressure - bar	10
Flow pressure, hot and cold - bar	0.5 to 5
Hot supply temperature - °C	55 to 65
Cold supply temperature - °C	5 to 25

Supply Conditions TMV3

Operating pressure range	High pressure
Maximum static pressure - bar	10
Flow pressure, hot and cold - bar	1 to 5
Hot supply temperature - °C	52 to 65
Cold supply temperature - °C	5 to 20

Installation Requirements

This thermostatic mixer valve must be installed in compliance with current Water Regulations. If you have any doubts about the Water Regulation requirements contact your local water services provider or use the services of a professional plumber.

This mixer valve is suitable for use with the following water supply systems:

- Gas Combination Boiler (multi-point) 1.0 - 10 bar*
- Unvented System (pressure balanced) 1.0 - 10 bar
- Pumped System 1.0 - 10 bar

IMPORTANT: If you install this mixer with a gravity fed system, there must be a minimum head (vertical distance) from the underside of the cold water storage tank to the showerhead position of at least 5 metre.

Before connecting the mixer, water should be flushed through the system to remove all debris that might otherwise damage the valve.

* If pressure is in excess of 3.5 bar, a pressure-reducing valve should be fitted.

KEY



Isolating valve



Reducing valve



Mixer Valve



Pump

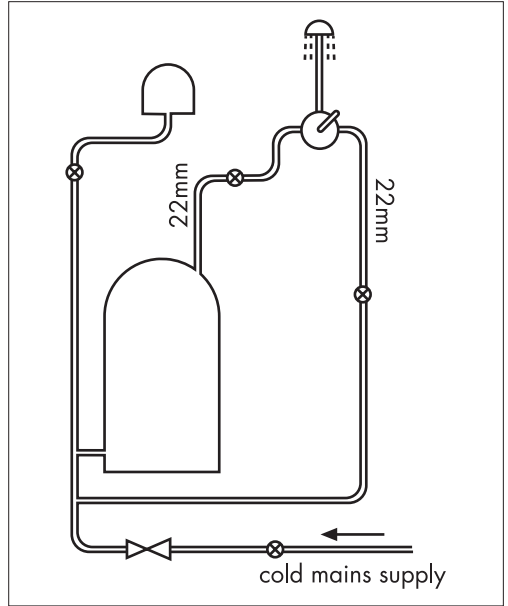

Unvented System (pressure balanced)

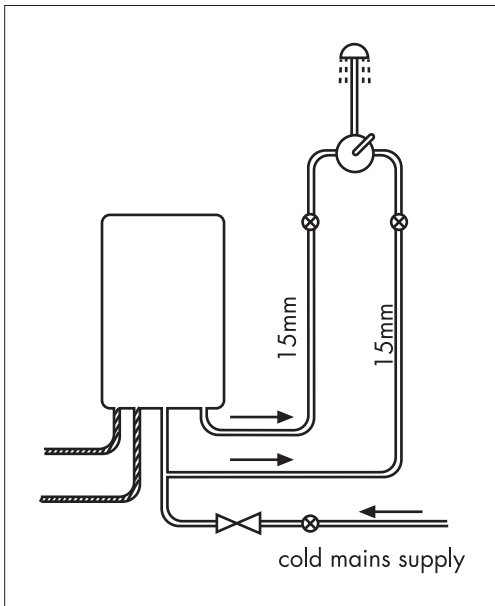

Gas Combination Boiler (multi-point)

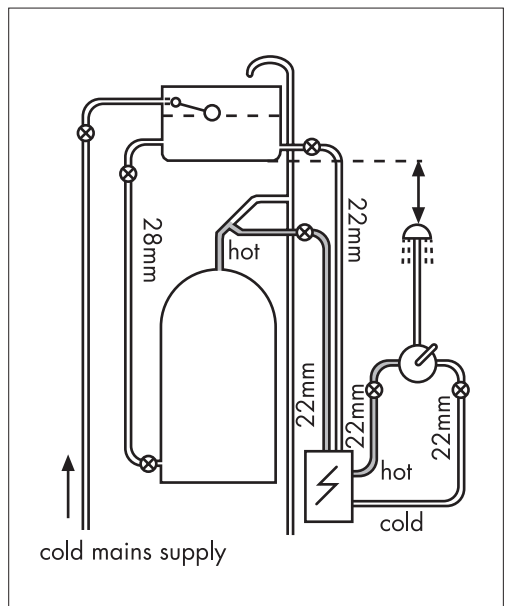

Pumped System

Commissioning and in-service tests

Commissioning

Purpose

Since the installed supply conditions are likely to be different from those applied in the laboratory tests it is appropriate, at commissioning, to carry out some simple checks and tests on each mixing valve to provide a performance reference point for future in-service tests.

Procedure

1. Check that:
 - a) the designation of the thermostatic mixing valve matches the intended application
 - b) the supply pressures are within the range of operating pressures for the designation of the valve
 - c) the supply temperatures are within the range permitted for the valve and by guidance information on the prevention of legionella etc.
2. Adjust the temperature of the mixed water in accordance with the manufacturer's instructions (page 20) and the requirement of the application and then carry out the following sequence:
 - a) record the temperature of the hot and cold water supplies
 - b) record the temperature of the mixed water at the largest draw-off flow rate
 - c) record the temperature of the mixed water at a smaller draw-off flow rate, which shall be measured
 - d) isolate the cold water supply to the mixing valve and monitor the mixed water temperature
 - e) record the maximum temperature achieved as a result of (d) and the final stabilised temperature

NOTE: The final stabilised mixed water temperature should not exceed the values in Table A.

- f) record the equipment, thermometer etc. used for the measurements

Table A: Guide to maximum stabilised temperatures recorded during site tests

Application	Mixed water temperature
Shower	43 °C
Washbasin	43 °C
Bath (44 °C fill)	46 °C
Bath (46 °C fill)	48 °C

The mixed water temperature at terminal fitting should never exceed 46°C.

If there is a residual flow during the commissioning or the annual verification (cold water supply isolation test), then this is acceptable providing the temperature of the water seeping from the valve is no more than 2 °C above the designated maximum mixed water outlet temperature setting of the valve.

Temperature readings should be taken at the normal flow rate after allowing for the system to stabilise.

The sensing part of the thermometer probe must be fully submerged in the water that is to be tested.

Any TMV that has been adjusted or serviced must be re-commissioned and re-tested in accordance with the manufacturers' instructions.

In-service tests

Purpose

The purpose of in-service tests is to regularly monitor and record the performance of the thermostatic mixing valve. Deterioration in performance can indicate the need for service work on the valve and/ or the water supplies.

Procedure

1. Carry out the procedure **2.** (a) to (e) on page 30 using the same measuring equipment, or equipment to the same specifications.
2. If the mixed water temperature has changed significantly from the previous test results (e.g. > 1 K), record the change and before re-adjusting the mixed water temperature check:
 - a) that any in-line or integral strainers are clean
 - b) any in-line or integral check valves or other anti-backsiphonage devices are in good working order
 - c) any isolating valves are fully open
3. With an acceptable mixed water temperature, complete the procedure **2.** (a) to (e) on page 30.
4. If at step **2.** (e) on page 30 the final mixed water temperature is greater than the values in Table A and / or the maximum temperature exceeds the corresponding value from the previous test results by more than about 2 K, the need for service work is indicated.

NOTE: In-service tests should be carried out with a frequency which identifies a need for service work before an unsafe water temperature can result. In the absence of any other instruction or guidance, the procedure described in „Frequency of in-service tests“ may be used.

Frequency of in-service tests TMV3*

General

In the absence of any other instruction or guidance on the means of determining the appropriate frequency of in-service testing, the following procedure may be used:

1. 6 to 8 weeks after commissioning carry out the tests given in **2.** on page 30.
2. 12 to 15 weeks after commissioning carry out the tests given in **2.** on page 30.
3. Depending on the results of **1.** and **4.** several possibilities exist:
 - a) If no significant changes (e.g. ≤ 1 K) in mixed water temperatures are recorded between commissioning and **1.**, or between commissioning and **4.** the next in-service test can be deferred to 24 to 28 weeks after commissioning.
 - b) If small changes (e.g. 1 to 2 K) in mixed water temperatures are recorded in only one of these periods, necessitating adjustment of the mixed water temperature, then the next in-service test can be deferred to 24 to 28 weeks after commissioning.
 - c) If small changes (e.g. 1 to 2 K) in mixed water temperatures are recorded in both of these periods, necessitating adjustment of the mixed water temperature, then the next in-service test should be carried out at 18 to 21 weeks after commissioning.
 - d) If significant changes (e.g. > 2 K) in mixed water temperatures are recorded in either of these periods, necessitating service work, then the next in-service test should be carried out at 18 to 21 weeks after commissioning.
4. The general principle to be observed after the first 2 or 3 in-service tests is that the intervals of future tests should be set to those which previous tests have shown can be achieved with no more than a small change in mixed water temperature.

***TMV2: The frequency of performing the in-service tests is 1 year maximum.**

Thermostatic Adjustment

Temperature Limitation

The temperature is limited by the safety stop to 40°C. If a higher temperature is required, it is possible to over ride the safety stop by depressing the safety button.

NB. It is recommended that for **private domestic use** the maximum mixed water temperature be set at the following factory set values:

Shower Mixer 43°C

Bath/Shower 43°C

Temperatures can be set by following the procedures on page 20. This ensures that after correct installation the outlet temperature of the water can never exceed 43°C.

To guarantee a smooth running of the thermostatic element, it is necessary from time to time to turn the thermostat from total hot to total cold. The thermostatic mixer valve should be checked annually by a qualified person to ensure correct operation.

The mixer is fitted with check valves (page 25 pos. 94074000) and filters (page 25 pos 94282000). If the water flow drops the filters need to be cleaned. For that purpose please follow the steps 1 - 12 on page 22.

Calibrating Thermostat

If the temperature reading is different to the showering temperature, follow the steps 1 - 3 on page 20.