

DE	Gebrauchsanleitung / Montageanleitung	2
FR	Mode d'emploi / Instructions de montage	3
EN	Instructions for use / assembly instructions	4

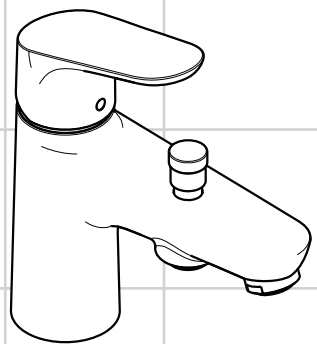

Focus E²
31938000



Ihr Online-Fachhändler für:

hansgrohe

- Kostenlose und individuelle Beratung
- Hochwertige Produkte
- Kostenloser und schneller Versand

- TOP Bewertungen
- Exzelerter Kundenservice
- Über 20 Jahre Erfahrung



E-Mail: info@unidomo.de | Tel.: 04621 - 30 60 89 0 | www.unidomo.de



Sicherheitshinweise

- Bei der Montage müssen zur Vermeidung von Quetsch- und Schnittverletzungen Handschuhe getragen werden.
- Das Produkt darf nur zu Bade-, Hygiene- und Körperreinigungszwecken eingesetzt werden.
- Große Druckunterschiede zwischen den Kalt- und Warmwasseranschlüssen müssen ausgeglichen werden.

Montagehinweise

- Die Armatur muss nach den gültigen Normen montiert, gespült und geprüft werden.
- ACHTUNG!** Um die Anschluss-Schläuche überprüfen zu können, muss eine Revisionsöffnung vorhanden sein.
- Vor der Montage muss das Produkt auf Transportschäden untersucht werden. Nach dem Einbau werden keine Transport- oder Oberflächenschäden anerkannt.

Technische Daten

Betriebsdruck:	max. 1 MPa
Empfohlener Betriebsdruck:	0,1 – 0,5 MPa
Prüfdruck:	1,6 MPa
(1 MPa = 10 bar = 147 PSI)	
Heißwassertemperatur:	max. 80 °C
Empfohlene Heißwassertemperatur:	65 °C
Thermische Desinfektion:	max. 70 °C / 4 min

- Eigensicher gegen Rückfließen
- Hansgrohe Armaturen können in Verbindung mit hydraulisch und thermisch gesteuerten Durchlauferhitzern eingesetzt werden, wenn der Fließdruck mindestens 0,15 MPa beträgt.
- Das Produkt ist ausschließlich für Trinkwasser konzipiert!

Störung	Ursache	Abhilfe
Wenig Wasser	- Siebdichtung der Brause verschmutzt	- Siebdichtung zwischen Brause und Schlauch reinigen
	- Rückflussverhinderer sitzt fest	- Rückflussverhinderer austauschen
Armatur schwergängig	- Kartusche defekt, verkalkt	- Kartusche austauschen
Armatur tropft	- Kartusche defekt	- Kartusche austauschen
Zu niedrige Warmwassertemperatur	- Warmwasserbegrenzung falsch eingestellt	- Warmwasserbegrenzung einstellen
Durchlauferhitzer schaltet nicht ein	- Drossel in der Handbrause nicht ausgebaut	- Drossel aus der Handbrause entfernen
	- Schmutzfangsiebe verschmutzt	- Schmutzfangsiebe reinigen / austauschen
	- Rückflussverhinderer sitzt fest	- Rückflussverhinderer austauschen

Symbolerklärung



Reinigung (Reinigung siehe beiliegende Broschüre.)



Justierung

Einhandmischer mit Warmwasserbegrenzung, Justierung siehe Seite 9. In Verbindung mit Durchlauferhitzern ist eine Warmwassersperre nicht zu empfehlen.



Wartung (siehe Seite 11)

Rückflussverhinderer müssen gemäß DIN EN 1717 regelmäßig in Übereinstimmung mit nationalen oder regionalen Bestimmungen (DIN 1988 einmal jährlich) auf ihre Funktion geprüft werden.

Kein essigsäurehaltiges Silikon verwenden!



Maße (siehe Seite 5)



Durchflussdiagramm

(siehe Seite 5)

- mit EcoSmart®
- ohne EcoSmart®



Serviceteile (siehe Seite 10)



Bedienung (siehe Seite 8)

Hansgrohe empfiehlt, morgens oder nach längeren Stagnationszeiten den ersten halben Liter nicht als Trinkwasser zu verwenden.



Prüfzeichen (siehe Seite 12)





Consignes de sécurité

- ⚠ Lors du montage, porter des gants de protection pour éviter toute blessure par écrasement ou coupure.
- ⚠ Le système de douche ne doit servir qu'à se laver et à assurer l'hygiène corporelle.
- ⚠ Il est conseillé d'équilibrer les pressions de l'eau chaude et froide.

Instructions pour le montage

- La robinetterie doit être installée, rincée et contrôlée conformément aux normes valables.
- ATTENTION! Pour des travaux d'entretien prévoir obligatoirement une trappe de visite.
- Avant son montage, s'assurer que le produit n'a subi aucun dommage pendant le transport. Après le montage, tout dommage de transport ou de surface ne pourra pas être reconnu.

Informations techniques

Pression de service autorisée:	max. 1 MPa
Pression de service conseillée:	0,1 – 0,5 MPa
Pression maximum de contrôle: (1 MPa = 10 bar = 147 PSI)	1,6 MPa
Température d'eau chaude:	max. 80 °C
Température recommandée:	65 °C
Désinfection thermique:	max. 70 °C / 4 min

- Avec dispositif anti-retour
- Les mitigeurs Hansgrohe fonctionnent également en association à des chauffe-eau à commande hydraulique ou thermique à condition que la pression soit au minimum de 0,15 MPa.
- Le produit est exclusivement conçu pour de l'eau potable!

Description du symbole



Nettoyage (Pour les conseils d'entretien, voir la brochure ci-jointe.)



Étalonnage

Mitigeur avec limitation de la température: voir la page 9 pour le réglage. Une limitation de la température n'est pas recommandée quand le mitigeur est alimenté par un chauffe-eau instantané.



Entretien (voir page 11)

Les clapets anti-retour doivent être examinés régulièrement conformément à la norme EN 1717 ou conformément aux dispositions nationales ou régionales quant à leur fonction (au moins une fois par an).

Ne pas utiliser de silicone contenant de l'acide acétique!



Dimensions (voir page 5)



Diagramme du débit

(voir page 5)

- ① avec EcoSmart®
- ② without EcoSmart®



Pièces détachées (voir pages 10)



Instructions de service

(voir page 8)

Hansgrohe recommande de ne pas utiliser le premier demi-litre le matin ou après une période de stagnation prolongée.

Classification acoustique et débit (voir page 12)





Dysfonctionnement	Origine	Solution
Pas assez d'eau	- Joint-filtre de douche encrassé	- Nettoyer le joint-filtre entre la douche et le flexible
	- Clapet anti-retour bloqué	- Changez le clapet anti-retour
Dureté de fonctionnement	- Cartouche défectueuse, entartrée	- Changer la cartouche
Le mitigeur goutte	- Cartouche défectueuse	- Changer la cartouche
Température d'eau chaude trop basse, pas d'eau froide	- Limiteur de température mal positionné	- Positionner le limiteur de température
La chauffe-eau instantané ne s'allume pas	- Réducteur de débit non démonté	- Démontez le réducteur de débit de la douche
	- Filtres encrassés	- Nettoyez / changez les filtres
	- Clapet anti-retour bloqué	- Changez le clapet anti-retour



Montage voir page 6



Safety Notes

-  Gloves should be worn during installation to prevent crushing and cutting injuries.
-  The shower system may only be used for bathing, hygienic and body cleansing purposes.
-  The hot and cold supplies must be of equal pressures.

Installation Instructions

- The fitting must be installed, flushed and tested after the valid norms.
- **IMPORTANT!** There must be an access door for maintenance.
- Prior to installation, inspect the product for transport damages.
After it has been installed, no transport or surface damage will be honoured.

Technical Data

Operating pressure:	max. 1 MPa
Recommended operating pressure:	0,1 – 0,5 MPa
Test pressure:	1,6 MPa
(1 MPa = 10 bar = 147 PSI)	
Hot water temperature:	max. 80 °C
Recommended hot water temp.:	65 °C
Thermal disinfection:	max. 70 °C / 4 min

- Anti-pollution function
- Hansgrohe mixers can be used together with hydraulically and thermically controlled continuous flow heaters if the flow pressure is at least 0,15 MPa.
- The product is exclusively designed for drinking water!

Symbol description



Cleaning (Cleaning recommendations, see enclosed brochure.)



Adjustment

To adjust the hot water limiter on single lever mixers, please see page 9. Using a hot water limiter in connection with a continuous flow water heater is not recommended.



Maintenance (see page 11)

The non return valves must be checked regularly according to DIN EN 1717 in accordance with national or regional regulations (at least once a year).



Do not use silicone containing acetic acid!



Dimensions (see page 5)



Flow diagram

(see page 5)

- ① with EcoSmart®
- ② without EcoSmart®



Spare parts (see page 10)



Operation (see page 8)

Hansgrohe recommends not to use as drinking water the first half liter of water drawn in the morning or after a prolonged period of non-use.



Test certificate (see page 12)

Fault	Cause	Remedy
Insufficient water	- Shower filter seal dirty	- Clean filter seal between shower and hose
	- Non return valve hasn't moved back	- Exchange non return valves
Mixer stiff	- Cartridge defective, calcified	- Exchange cartridge
Mixer dripping	- Cartridge defective	- Exchange cartridge
Hot water temperature too low	- Hot water limiter incorrectly set	- Set hot water limiter
Instantaneous heater didn't work	- Flow limiter in handshower isn't removed	- Remove flow limiter
	- Filters are dirty	- Clean the filter / exchange filter
	- Non return valve hasn't moved back	- Exchange non return valves



Assembly see page 6

Focus E² 31938000

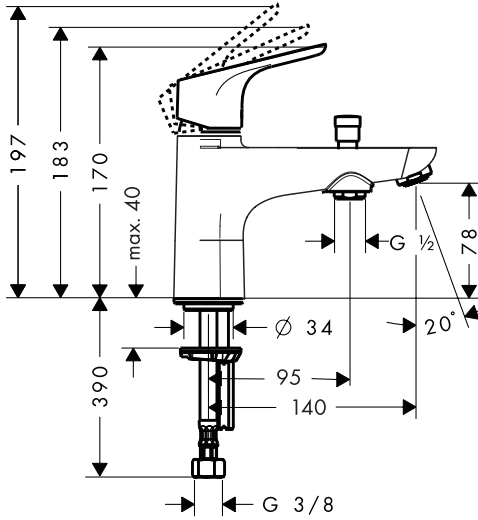

Focus E² 31938000

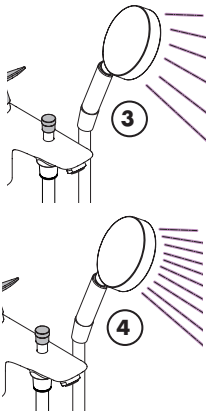
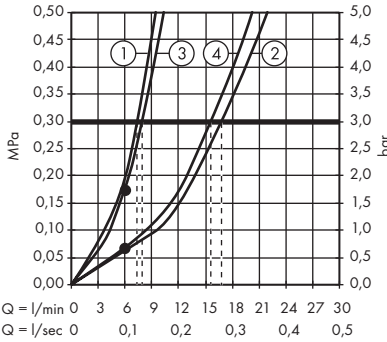

1B Widerstand / 1B résistance / 1B resistance / 1B Resistenza / 1B resistencia / 1B Weerstand / 1B Modstand / 1B Resistência / 1B Opór / 1B Odpor / 1B Odpor / 1B 等级 / 1B Сопротивление / 1B Ellenállás / 1B virtausvastus / 1B Motstånd / 1B Pasipriešinimas / 1B otpor / 1B Direnc / 1B Rezistență / 1B Αντίσταση / 1B Upor / 1B takistus / 1B Pretestība / 1B otpor / 1B Motstand / 1B Съпротивление / 1B resistencia / 1B مقوماتها

1B Widerstand / 1B résistance / 1B resistance / 1B Resistenza / 1B resistencia / 1B Weerstand / 1B Modstand / 1B Resistência / 1B Opór / 1B Odpor / 1B Odpor / 1B 等级 / 1B Сопротивление / 1B Ellenállás / 1B virtausvastus / 1B Motstånd / 1B Pasipriešinimas / 1B otpor / 1B Direnc / 1B Rezistență / 1B Αντίσταση / 1B Upor / 1B takistus / 1B Pretestība / 1B otpor / 1B Motstand / 1B Съпротивление / 1B resistencia / 1B مقوماتها

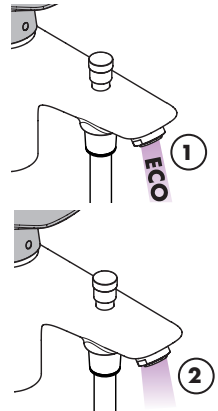

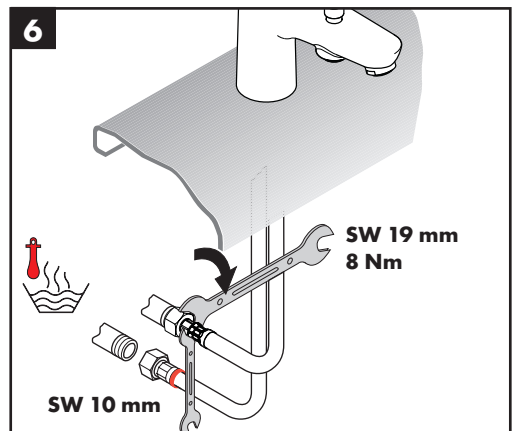
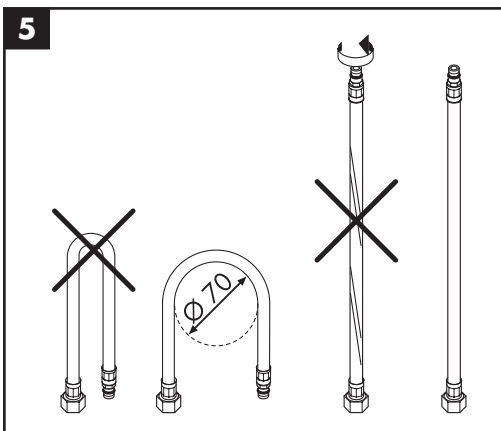
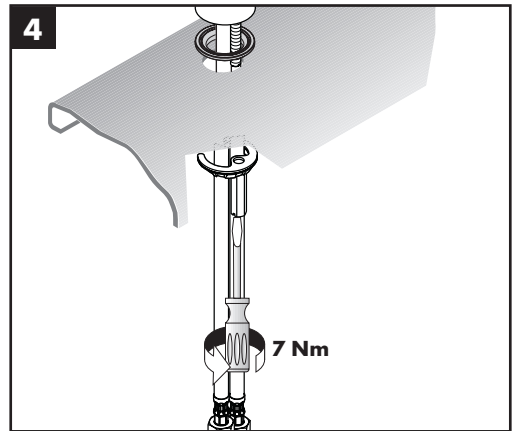
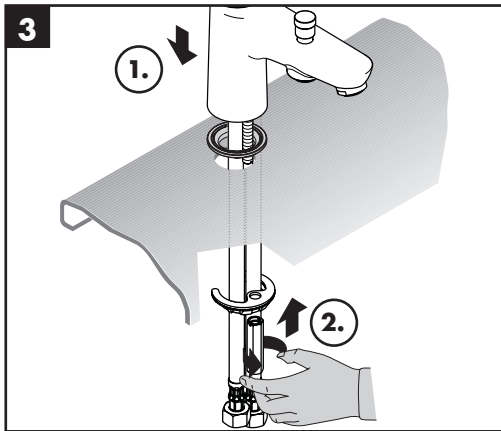
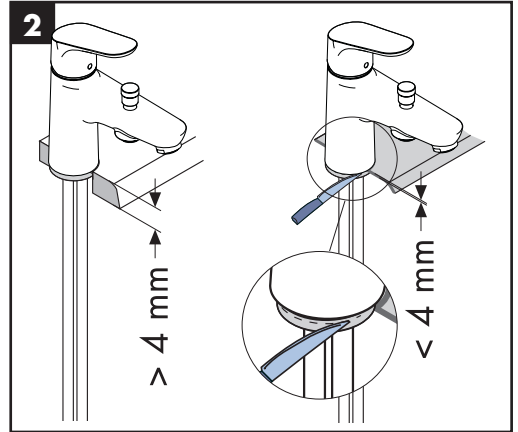
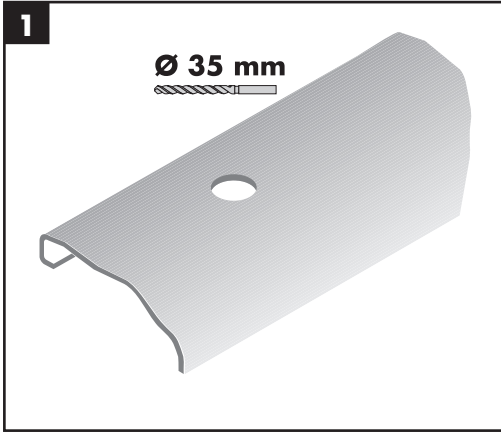

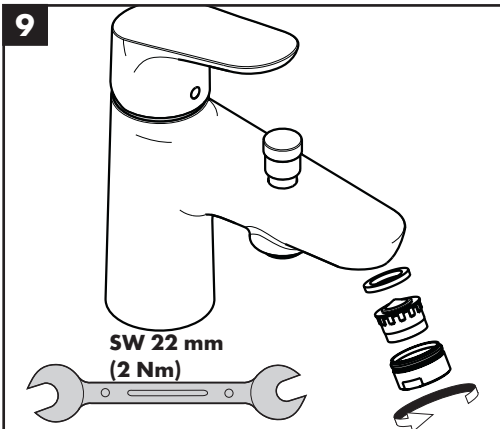
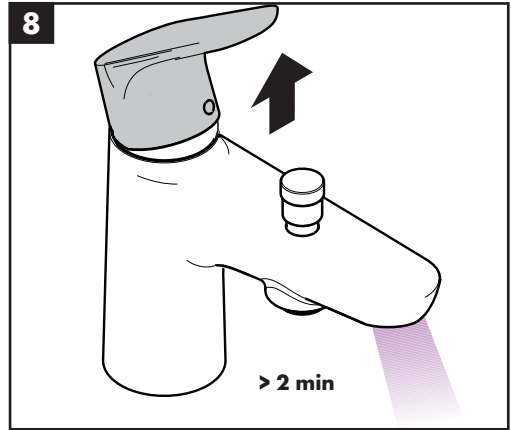
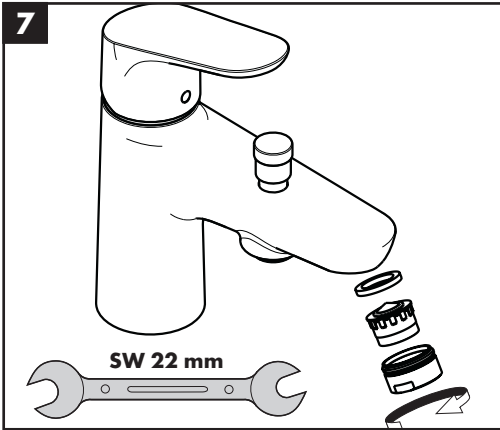

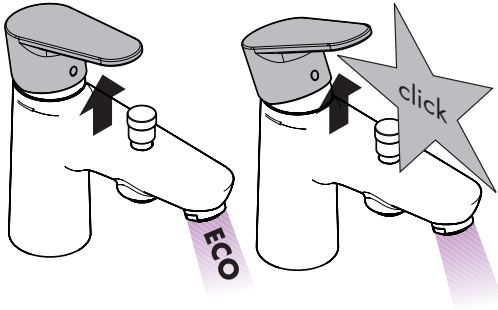

öffnen / ouvert / open

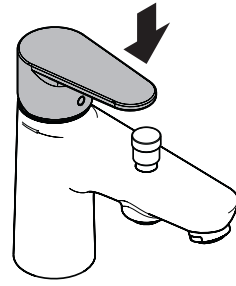

schließen / fermé / close

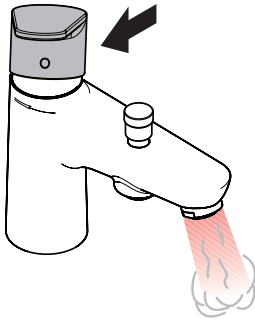

warm / chaud / hot

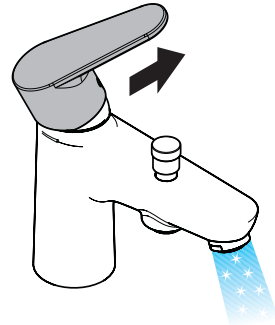

kalt / froid / cold

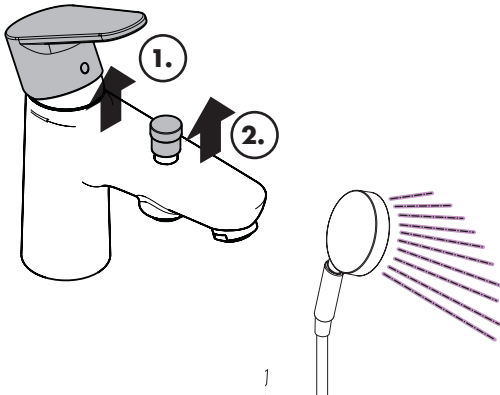

öffnen Handbrause / ouvert Douchette /
open hand shower

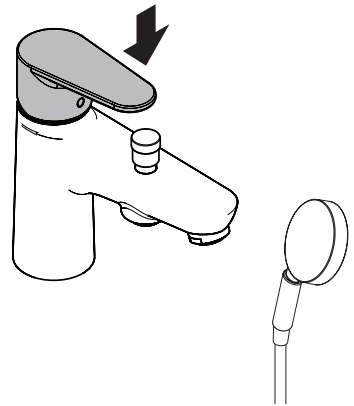

schließen Handbrause / fermé Douchette /
close hand shower

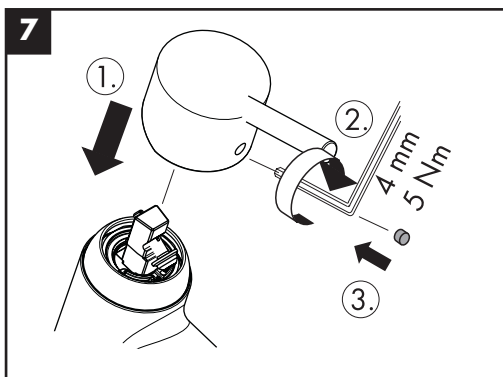
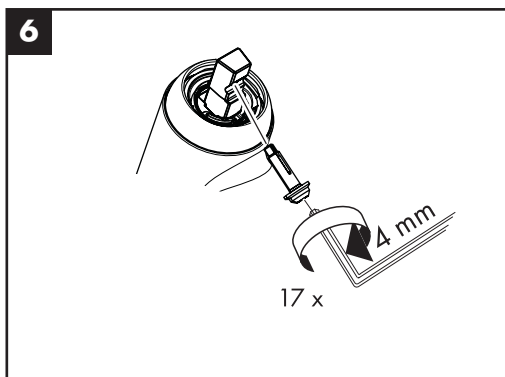
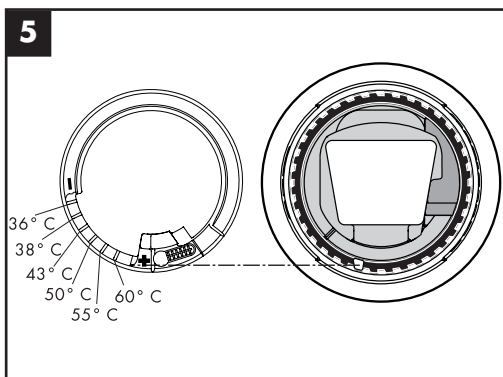
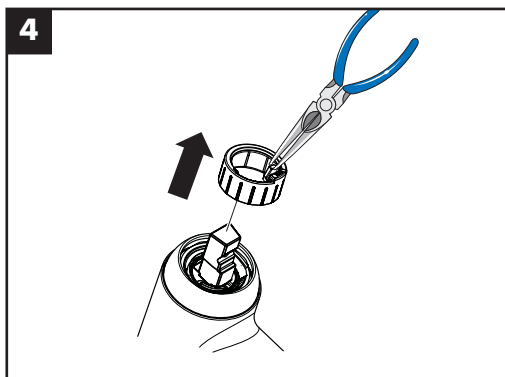
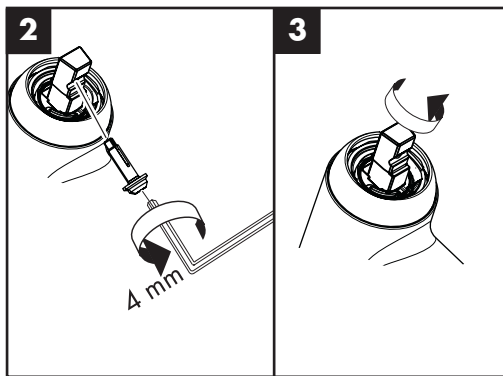
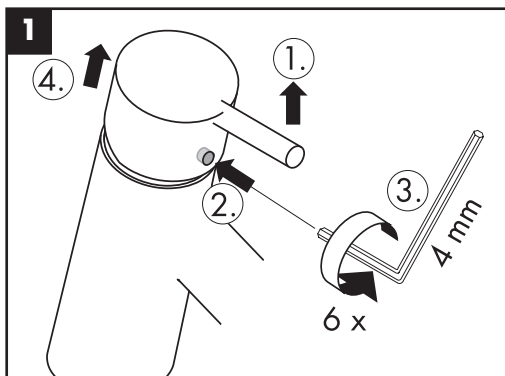

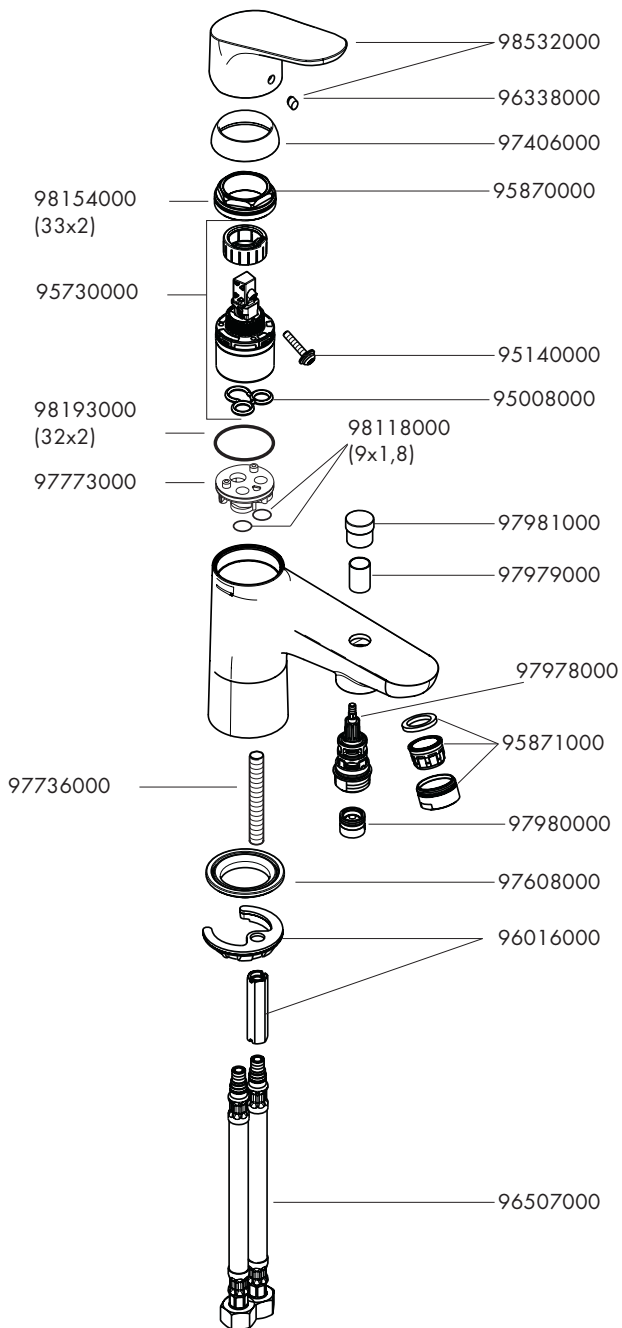

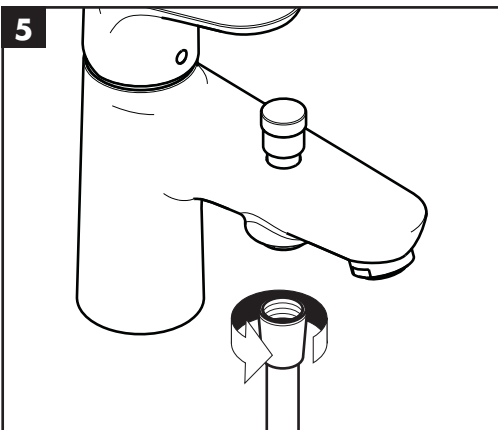
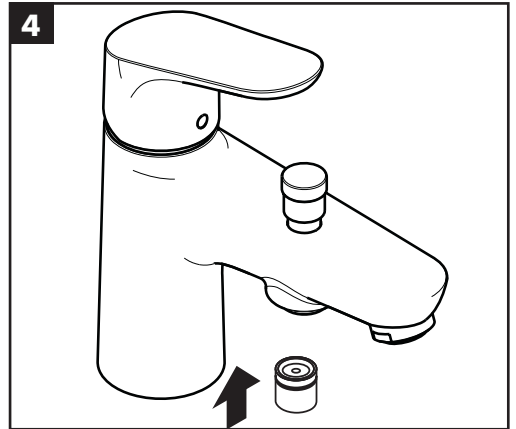
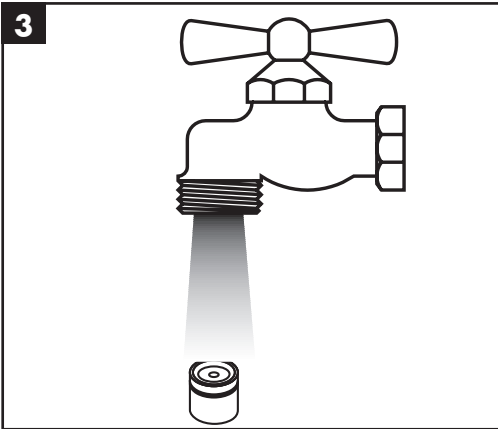
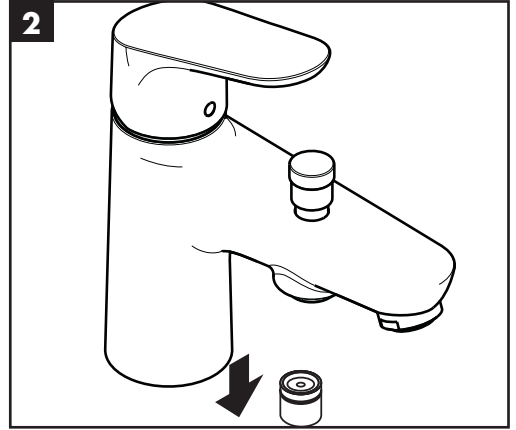
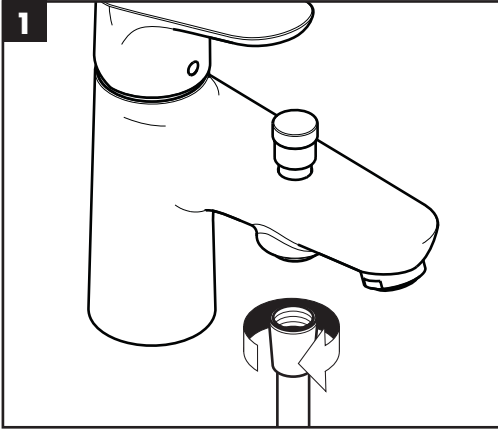



	PA-IX	DVGW	SVGW	NF	WRAS	KIWA	ACS	ETA
31938000				X			X	
