

Installation Instructions / Warranty

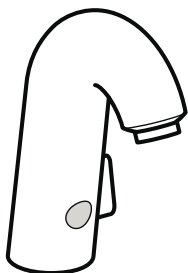

Electronic
15180XX1

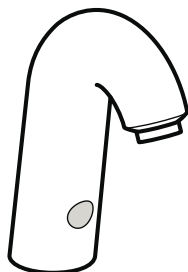

Electronic
15181XX1

hansgrohe



Ihr Online-Fachhändler für:

hansgrohe

- Kostenlose und individuelle Beratung
- Hochwertige Produkte
- Kostenloser und schneller Versand

- TOP Bewertungen
- Exzelerter Kundenservice
- Über 20 Jahre Erfahrung



E-Mail: info@unidomo.de | Tel.: 04621 - 30 60 89 0 | www.unidomo.de

Hansgrohe Electronic Lavatory Faucet with Temperature Control
 15180XX1
 Hansgrohe Electronic Lavatory Faucet
 15181XX1

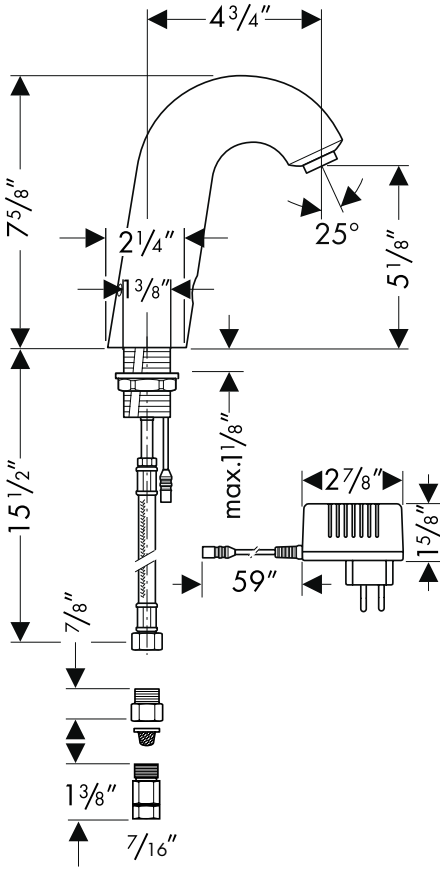

Technical data

Max. water pressure:	116 psi
Recommended pressure:	14.5 - 72 psi
Hot water temperature:	max. 158 °F*
Recommended hot water temperature:	120°F - 140°F*
Rate of flow:	1.5 gpm @ 44 psi
Automatic shutoff:	after 35 seconds
Hole size in mounting surface:	1 $\frac{3}{8}$ "
Max. mounting surface thickness:	1 $\frac{1}{8}$ "
Requires standard 110V electrical outlet.**	

*please know and follow all applicable local plumbing codes when setting the temperature on the water heater. In Massachusetts, the water heater may be set no higher than 112°F.

**please know and follow all applicable local codes regarding placement and type of outlet.

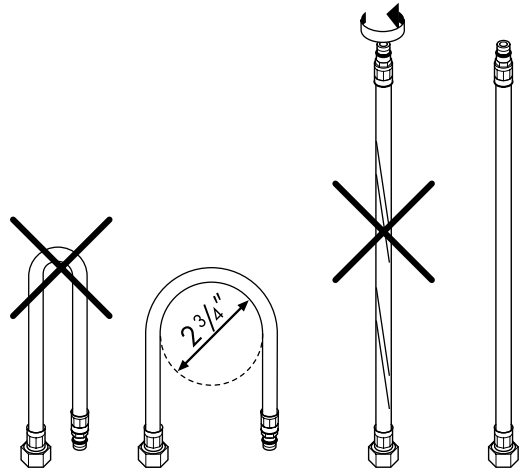

Caution: do not bend or twist the supply hoses!

Installation

Flush the hot and cold supplies thoroughly before installing this faucet.

Place the faucet in the hole in the mounting surface (1).

From beneath the sink, install the fiber washer, metal washer and mounting nut (2).

Install the adapters on the stops (3).

Install the filters (4) and supply lines (5).

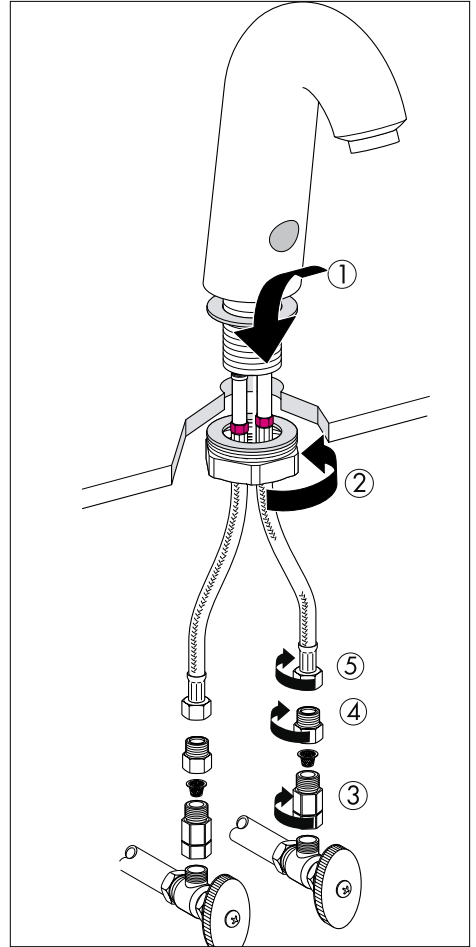

Connect the transformer. Plug into the outlet.

Use a cable tie to bundle excess cable.

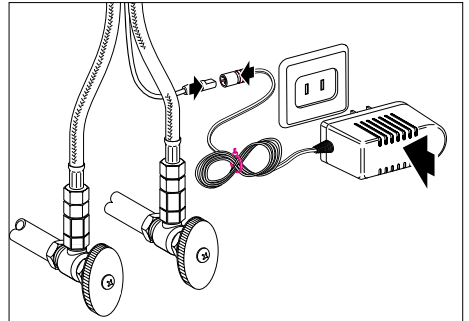

Turn the water on to the faucet (1).

Peel the protective film from the sensor (2).

Wait 15 seconds, then put a hand in front of the sensor.
The water should turn on automatically.

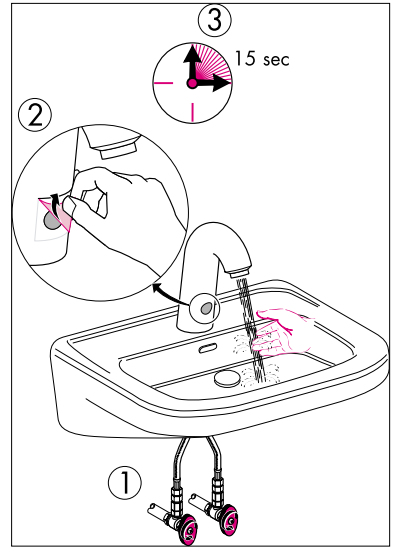

Model 15180 only: Pivot the temperature control lever forward to make the water cooler.

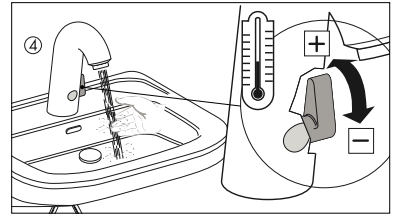

Model 15181 only: Turn the water off at the stops (1).

Remove the set screw on the back of the faucet (2).

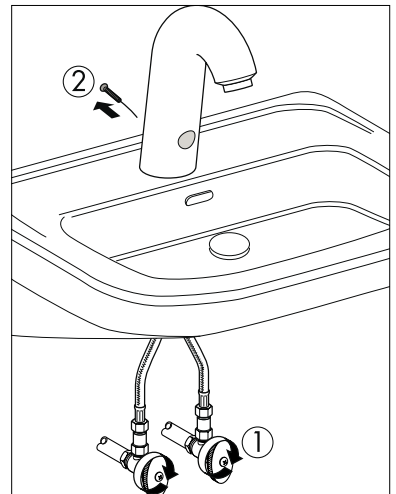

Pull the faucet housing off (1).

Use a screwdriver to set the water temperature (2). Turn the screw to the rear to make the water warmer, to the front to make it cooler.

Replace the faucet housing. Tighten the set screw.

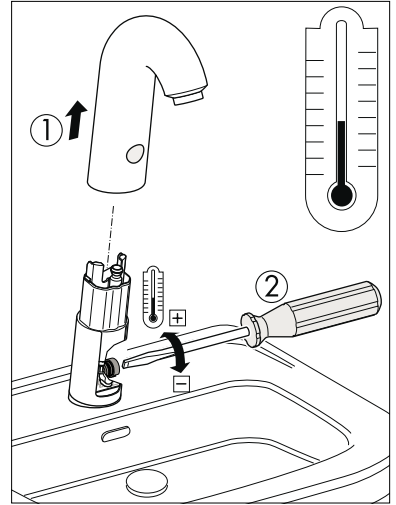

Cleaning: Block the sensor for 5 seconds (1).

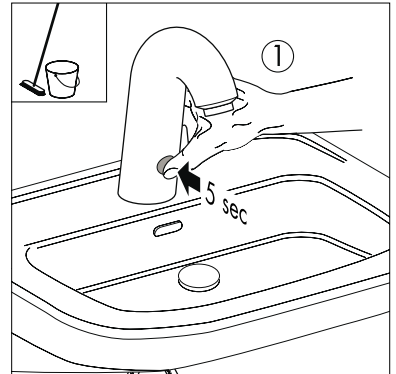

This will turn the water off for approximately 75 seconds so that the sink may be cleaned (2).

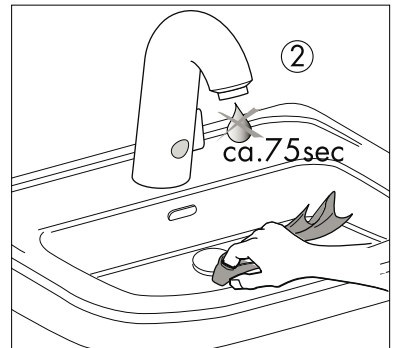

Faucet Maintenance

Reset the faucet: Remove the set screw with a 2.5 mm Allen wrench.

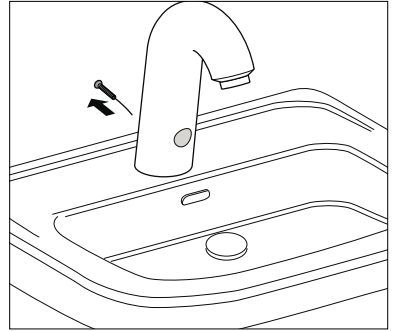

Block the sensor for 2 seconds.

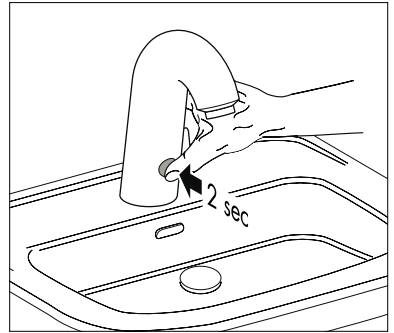

Wait 10 seconds (1), then replace the set screw (2).

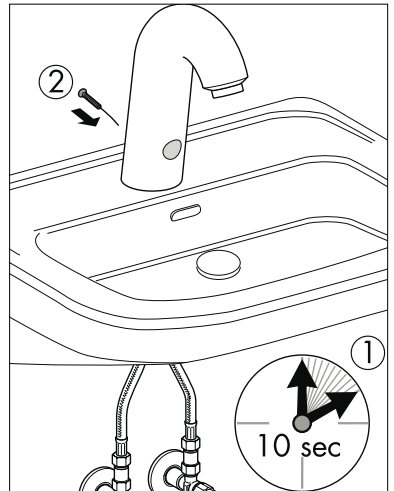

Wait 15 seconds (3), then place a hand in front of the sensor (4). The water should turn on.

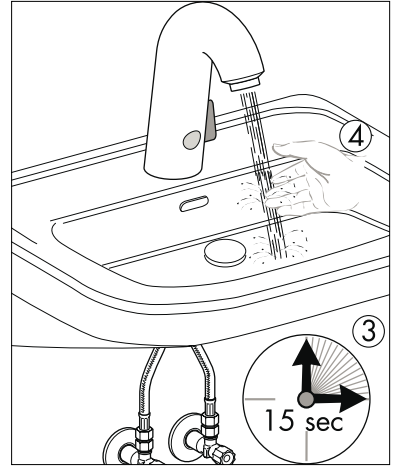

Cleaning the filters and aerator

If the flow of water is reduced, the filters and/or the aerator must be cleaned.

To clean the aerator: Block the sensor for 5 seconds to temporarily shut off the water (1).

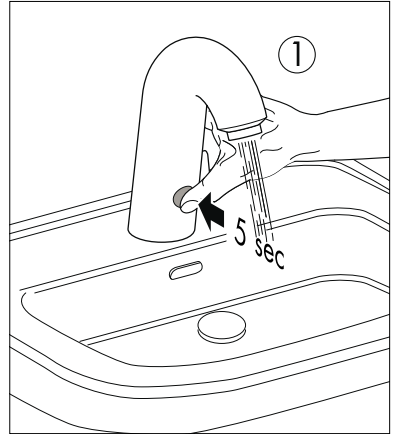

Unscrew and remove the aerator. Flush any debris from the aerator at another faucet (2).

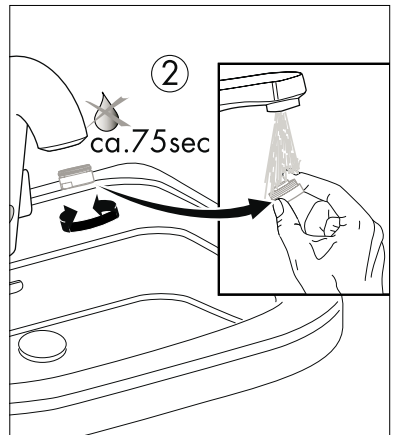

To clean the filters: Turn the water off at the stops (1).

Disconnect the supply hoses from the adapters (2). Pull the filters out and clean them.

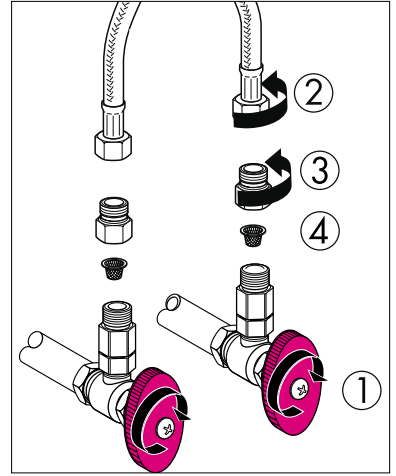

Replacement Parts

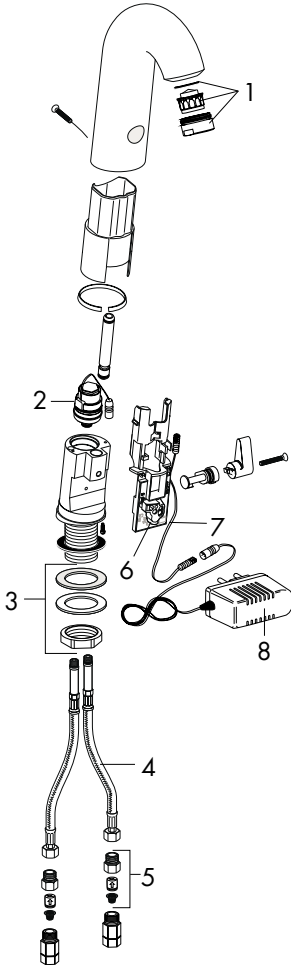

1	aerator	96788XXX
2	solenoid valve	98854000
3	fixation set	97812000
4	connection hose	96405000
5	back flow preventor cartridge	96906000
6	electronics	96905000
7	AC adapter	97690000
8	transformer	97689001

Cleaning Recommendation for Hansgrohe Products

Modern faucetry and shower products utilize a combination of materials to comply with the needs of the market with regard to design and functionality.

To avoid damage, it is necessary to use some caution when cleaning. Damage caused by improper treatment is not covered under the Hansgrohe warranty.

Cleaning Materials for Faucets and Showers

- To remove lime scale, use only products made specifically for that purpose. Always follow the manufacturer's instructions when using.
- Do not use cleaners that contain hydrochloric, formic, acetic, or phosphoric acids, as these will cause considerable damage to finishes and to plastic components.
- Never mix cleaning materials.
- Never use cleaners containing abrasives. Do not use abrasive cleaning cloths, pads, or sponges.

Cleaning Procedures

- Clean your faucets and shower products as and when required. Regular cleaning will prevent scale buildup and water spotting.
- Follow the label instructions. Do not allow any cleaner to remain on the product for longer than necessary.
- When using spray cleaners, spray first onto a sponge or cloth – do not spray directly onto the product.
- After cleaning, rinse thoroughly with clear water to remove any cleaner residue.

Important

- Soap and shampoo residue can also cause damage to the product. Rinse well with clean water after use.
- If the surface is already damaged, harsh cleaning materials will cause further damage.

Limited Lifetime Consumer Warranty

This product has been manufactured and tested to the highest quality standards by Hansgrohe, Inc. ("Hansgrohe"). This warranty is limited to Hansgrohe products which are purchased by a consumer in the United States after March 1, 1996, and installed in either the United States or Canada.

WHO IS COVERED BY THE WARRANTY

This warranty extends to the original consumer purchaser only. This warranty is non-transferable.

WHAT IS COVERED BY THE WARRANTY

This warranty covers only your Hansgrohe manufactured product. Hansgrohe warrants this product against defects in material or workmanship as follows: Hansgrohe will repair at no charge for parts only or, at its option, replace any product or part of the product that proves defective because of improper workmanship and/or material, under normal installation, use, service and maintenance. If Hansgrohe is unable to provide a replacement and repair is not practical or cannot be timely made, Hansgrohe may elect to refund the purchase price in exchange for the return of the product.

LENGTH OF WARRANTY

Replacement or repaired parts of products will be covered for the term of this warranty as stated in the following two sentences. If you are a consumer who purchased the product for use primarily for personal, family, or household purposes, this warranty extends for as long as you own the product and the home in which the product is originally installed. If you purchased the product for use primarily for any other purpose, including, without limitation, a commercial purpose, this warranty extends only (i) for 1 year, with respect to Hansgrohe and Commercial products, and (ii) for 5 years, with respect to AXOR products.

THIS WARRANTY DOES NOT COVER, AND HANSGROHE WILL NOT PAY FOR:

- A. Conditions, malfunctions or damage not resulting from defects in material or workmanship.
- B. Conditions, malfunctions or damage resulting from (1) normal wear and tear, improper installation, improper maintenance, misuse, abuse, negligence, accident or alteration, or (2) the use of abrasive or caustic cleaning agents or "no-rinse" cleaning products, or the use of the product in any manner contrary to the product instructions. (3) Conditions in the home such as excessive water pressure or corrosion.
- C. Labor or other expenses for the disconnection, deinstallation, or return of the product for warranty service, or for installation or reinstallation of the product (including but not limited to proper packaging and shipping costs), or for installation or reinstallation of the product.
- D. Accessories, connected materials and products, or related products not manufactured by Hansgrohe.

TO OBTAIN WARRANTY PARTS OR INFORMATION

Contact your Hansgrohe retailer, or contact Technical Service at:

Hansgrohe Inc.
1492 Bluegrass Lakes Parkway
Alpharetta GA 30004
Toll-free (800) 334-0455.

In requesting warranty service, you will need to provide

1. The sales receipt or other evidence of the date and place of purchase.
2. A description of the problem.
3. Delivery of the product or the defective part, postage prepaid and carefully packed and insured, to Hansgrohe Inc. 1492 Bluegrass Lakes Parkway, Alpharetta, Georgia 30004, Attention: Technical Service, if required by Hansgrohe.

When warranty service is completed, any repaired or replacement product or part will be returned to you postage prepaid.

EXCLUSIONS AND LIMITATIONS

REPAIR OR REPLACEMENT (OR, IN LIMITED CIRCUMSTANCES, REFUND OF THE PURCHASE PRICE) AS PROVIDED UNDER THIS WARRANTY IS THE EXCLUSIVE REMEDY OF THE PURCHASER. HANSGROHE NEITHER ASSUMES NOR AUTHORIZES ANY PERSON TO CREATE FOR IT ANY OBLIGATION OR LIABILITY IN CONNECTION WITH THIS PRODUCT.

HANSGROHE SHALL NOT BE LIABLE TO PURCHASER OR ANY PERSON FOR ANY INCIDENTAL, SPECIAL, OR CONSEQUENTIAL DAMAGES, ARISING OUT OF BREACH OF THIS WARRANTY OR ANY IMPLIED WARRANTY (INCLUDING MERCHANTABILITY).

Some States do not allow the exclusion or limitation of incidental or consequential damages, so the above limitation or exclusion may not apply to you. This warranty gives you specific legal rights, and you may have other rights which vary from State to State. You may be required by law to give us a reasonable opportunity to correct or cure any failure to comply before you can bring any action in court against us under the Magnuson-Moss Warranty Act.

PRODUCT INSTRUCTIONS AND QUESTIONS

Upon purchase or prior to installation, please carefully inspect your Hansgrohe product for any damage or visible defect. Prior to installing, always carefully study the enclosed instructions on the proper installation and the care and maintenance of the product. If you have questions at any time about the use, installation, or performance of your Hansgrohe product, or this warranty, please call or write to us or call us toll-free at 800 334 0455.

hansgrohe

Hansgrohe, Inc. • 1490 Bluegrass Lakes Parkway • Alpharetta, GA 30004
Tel. 770 360-9880 • Fax 770 360 9887

www.hansgrohe-USA.com