

DE	Gebruiksaanleitung / Montageanleitung	2
FR	Mode d'emploi / Instructions de montage	2
EN	Instructions for use / assembly instructions	3
IT	Istruzioni per l'uso / Istruzioni per Installazione	3
ES	Modo de empleo / Instrucciones de montaje	4
NL	Gebruiksaanwijzing / Handleiding	4
DK	Brugsanvisning / Monteringsvejledning	5
PT	Instruções para uso / Manual de Instalação	5
PL	Instrukcja obsługi / Instrukcja montażu	6
CS	Návod k použití / Montážní návod	6
SK	Návod na použitie / Montážny návod	7
ZH	用户手册 / 组装说明	7
RU	Руководство пользователя / Инструкция по монтажу	8
HU	Használati útmutató / Szerelési útmutató	8
FI	Käyttöohje / Asennusohje	9
SV	Bruksanvisning / Monteringsanvisning	9
LT	Vartotojo instrukcija / Montavimo instrukcijos	10
HR	Upute za uporabu / Uputstva za instalaciju	10
TR	Kullanım kılavuzu / Montaj kılavuzu	11
RO	Manual de utilizare / Instrucțiuni de montare	11
EL	Οδηγίες χρήσης / Οδηγία συναρμολόγησης	12
SL	Navodilo za uporabo / Navodila za montažo	12
ET	Kasutusjuhend / Paigaldusjuhend	13
LV	Lietošanas pamācība / Montāžas instrukcija	13
SR	Uputstvo za upotrebu / Uputstvo za montažu	14
NO	Bruksanvisning / Montasjeveiledning	14
BG	Инструкция за употреба / Ръководство за монтаж	15
SQ	Udhëzuesi i përdorimit / Udhëzime rreth montimit	15
AR	دليل الاستخدام / تعليمات التجميع	16

Raindance E 150 AIR 3jet
28551000

Raindance E 120 AIR 3jet
28549000

Raindance E 100 AIR 3jet
28553000

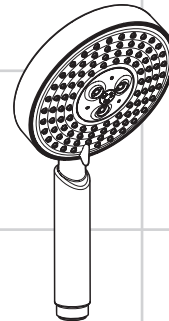

Raindance S 150 AIR 3jet
28550000

Raindance S 120 AIR 3jet
28554000

Raindance S 100 AIR 3jet
28552000



Ihr Online-Fachhändler für:

hansgrohe

- Kostenlose und individuelle Beratung
- Hochwertige Produkte
- Kostenloser und schneller Versand

- TOP Bewertungen
- Exzelerter Kundenservice
- Über 20 Jahre Erfahrung



E-Mail: info@unidomo.de | Tel.: 04621 - 30 60 89 0 | www.unidomo.de



Sicherheitshinweise

- Bei der Montage müssen zur Vermeidung von Quetsch- und Schnittverletzungen Handschuhe getragen werden.
- Der Kontakt der Brausestrahlen mit empfindlichen Körperstellen (z. B. Augen) muss vermieden werden. Es muss ein ausreichender Abstand zwischen Brause und Körper eingehalten werden.
- Die Brause darf nur zur Bade-, Hygiene- und Körperreinigungszwecke eingesetzt werden.

Montagehinweise

- Die der Brause beige packte Siebdichtung muss eingebaut werden, um Schmutzeinspülungen aus dem Leitungsnetz zu vermeiden. Schmutzeinspülungen können die Funktion beeinträchtigen und/oder zu Beschädigungen an Funktionsteilen der Brause führen, für hieraus ergebende Schäden haftet Hansgrohe nicht.
- Vor der Montage muss das Produkt auf Transportschäden untersucht werden. Nach dem Einbau werden keine Transport- oder Oberflächenschäden anerkannt.

Technische Daten

Betriebsdruck:	max. 0,6 MPa
Empfohlener Betriebsdruck:	0,1 – 0,4 MPa
(1 MPa = 10 bar = 147 PSI)	
Heißwassertemperatur:	max. 60°C
Thermische Desinfektion:	70°C / max. 4min

Das Produkt ist ausschließlich für Trinkwasser konzipiert!

Symbolerklärung



Maße (siehe Seite 17)



Durchflussdiagramm (siehe Seite 17)



Bedienung (siehe Seite 20)



Serviceteile (siehe Seite 22)



Reinigung (siehe Seite 21) und beiliegende Broschüre



Prüfzeichen (siehe Seite 19)

Consignes de sécurité

- Lors du montage, porter des gants de protection pour éviter toute blessure par écrasement ou coupure.
- Éviter le contact du jet de la douchette avec les parties sensibles du corps (telles par ex. que les yeux). Veiller à respecter un écart suffisant entre la douchette et le corps
- La douchette ne doit servir qu'à se doucher, à se nettoyer et à pratiquer une hygiène corporelle.

Instructions pour le montage

- Le joint à filtre fourni avec la pomme de douche à main doit être installé afin de retenir des impuretés du système de conduites. Ceux-ci pourraient influencer le fonctionnement de ce produit et même endommager des pièces mobiles. Des réclamations à la suite de l'usage de la pomme de douche sans joint-tamis de hansgrohe ne peuvent pas faire partie de notre garantie.
- Avant son montage, s'assurer que le produit n'a subi aucun dommage pendant le transport. Après le montage, tout dommage de transport ou de surface ne pourra pas être reconnu.

Informations techniques

Pression de service autorisée:	max. 0,6 MPa
Pression de service conseillée:	0,1 – 0,4 MPa
(1 MPa = 10 bar = 147 PSI)	
Température d'eau chaude:	max. 60°C
Désinfection thermique:	70°C / max. 4min

Le produit est exclusivement conçu pour de l'eau potable!

Description du symbole



Dimensions (voir page 17)



Diagramme du débit (voir page 17)



Instructions de service (voir page 20)



Pièces détachées (voir pages 22)



Nettoyage (voir page 21) et brochure ci-jointe



Classification acoustique et débit (voir page 19)



Montage



siehe Seite 19

Montage

voir page 19



Safety Notes

-  Gloves should be worn during installation to prevent crushing and cutting injuries.
-  Do not allow the streams of the shower touch sensitive body parts (such as your eyes). An adequate distance must be kept between the shower and you.
-  The shower may only be used for bathing, hygiene and body cleansing purposes.

Installation Instructions

- The mesh washer must be insert to protect the overhead shower against incoming dirt by pipework. Incoming dirt leads to defects or/and can damage parts of the shower; such caused faults voids all liability and guarantee claims.
- Prior to installation, inspect the product for transport damages. After it has been installed, no transport or surface damage will be honoured.

Technical Data

Operating pressure:	max. 0,6 MPa
Recommended operating pressure:	0,1 - 0,4 MPa
(1 MPa = 10 bar = 147 PSI)	
Hot water temperature:	max.60°C
Thermal disinfection:	70°C / max. 4min

The product is exclusively designed for drinking water!

Symbol description



Dimensions (see page 17)



Flow diagram (see page 17)



Operation (see page 20)



Spare parts (see page 22)



Cleaning (see page 21) and enclosed brochure





Test certificate (see page 19)

Assembly
see page 19



Indicazioni sulla sicurezza

-  Durante il montaggio, per evitare ferite da schiacciamento e da taglio bisogna indossare guanti protettivi.
-  Bisogna evitare il contatto fra il getto della doccia e parti del corpo delicate (ad es. gli occhi). Fra il soffione ed il corpo va mantenuta una distanza sufficiente.
-  La doccia deve essere impiegata solo per il bagno e utilizzo igienico e pulizia del corpo.

Istruzioni per il montaggio

- Per proteggere la soffione doccia da eventuali impurità provenienti dalle tubazioni dell'acqua, deve essere inserito il filtro nell'impugnatura della doccia stessa. Tali impurità possono infatti causare difetti e/o danneggiare parti della doccia; in questo caso la Hansgrohe non risponde dei danni.
- Prima del montaggio è necessario controllare che non ci siano stati danni durante il trasporto. Una volta eseguito il montaggio, non verranno riconosciuti eventuali danni di trasporto o delle superfici.

Dati tecnici

Pressione d'uso:	max. 0,6 MPa
Pressione d'uso consigliata:	0,1 - 0,4 MPa
(1 MPa = 10 bar = 147 PSI)	
Temperatura dell'acqua calda:	max.60°C
Disinfezione termica:	70°C / max. 4min

Il prodotto è concepito esclusivamente per acqua potabile!

Descrizione simbolo



Ingombri (vedi pagg. 17)



Diagramma flusso (vedi pagg. 17)



Procedura (vedi pagg. 20)



Parti di ricambio (vedi pagg. 22)



Pulitura (vedi pagg. 21) e brochure allegata



Segno di verifica (vedi pagg. 19)

Montaggio
vedi pagg. 19



Indicaciones de seguridad

- ⚠ Durante el montaje deben utilizarse guantes para evitar heridas por aplastamiento o corte.
- ⚠ Debe evitarse el contacto del chorro del pulverizador con partes sensibles del cuerpo (por ej. ojos). Debe mantenerse una distancia suficiente entre pulverizador y cuerpo.
- ⚠ La roseta de ducha solo debe utilizarse para fines de baño, higiene y limpieza corporal.

Indicaciones para el montaje

- La junta de filtración que se suministra con la ducha mural evita que las partículas de suciedad procedentes de las tuberías lleguen a la ducha mural. Debe colocarse entre el flexo y la ducha mural. Infiltraciones de suciedad deterioran el funcionamiento de la ducha mural y pueden causar daños en el interior de la misma que no están cubiertas por la garantía de Hansgrohe.
- Antes del montaje se debe examinar el producto contra daños de transporte. Después de la instalación so se reconoce ningún daño de transporte o de superficie.

Datos técnicos

Presión en servicio:	max. 0,6 MPa
Presión recomendada en servicio:	0,1 – 0,4 MPa
(1 MPa = 10 bar = 147 PSI)	
Temperatura del agua caliente:	max. 60°C
Desinfección térmica:	70°C / max. 4min

El producto ha sido concebido exclusivamente para agua potable.

Descripción de símbolos

-  **Dimensiones** (ver página 17)
-  **Diagrama de circulación** (ver página 17)
-  **Manejo** (ver página 20)
-  **Repuestos** (ver página 22)
-  **Limpiar** (ver página 21) y folleto anexo
-  **Marca de verificación** (ver página 19)

Montaje
ver página 19

Veiligheidsinstructies

- ⚠ Bij de montage moeten ter voorkoming van knel- en snijwonden handschoenen worden gedragen.
- ⚠ Het contact van de douchestraal met gevoelige lichaamsdelen (bijv. ogen) moet worden voorkomen. Er moet voldoende afstand tussen douche en lichaam aangehouden worden.
- ⚠ De douche uitsluitend toepassen in badkamers ten behoeve van lichaamsreiniging.

Montage-instructies







- Het bij de hoofddouche verpakte zeefje moet worden ingebouwd om vuil uit de waterleiding te weren. Vuil uit de leidingen kan de werking van de hoofddouche negatief beïnvloeden en/of de hoofddouche beschadigen. Voor deze schade is Hansgrohe niet verantwoordelijk.
- Vóór de montage moet het product gecontroleerd worden op transportschade. Na de inbouw wordt geen transport- of oppervlakteschade meer aanvaard.

Technische gegevens

Werkdruk: max.	max. 0,6 MPa
Aanbevolen werkdruk:	0,1 – 0,4 MPa
(1 MPa = 10 bar = 147 PSI)	
Temperatuur warm water:	max. 60°C
Thermische desinfectie:	70°C / max. 4min

Het product is uitsluitend ontworpen voor drinkwater!

Symboolbeschrijving

-  **Maten** (zie blz. 17)
-  **Doorstroombiagram** (zie blz. 17)
-  **Bediening** (zie blz. 20)
-  **Service onderdelen** (zie blz. 22)
-  **Reinigen** (zie blz. 21) en bijgevoegde brochure
-  **Keurmerk** (zie blz. 19)

Montage
zie blz. 19





! Sikkerhedsanvisninger

- △ Ved monteringen skal der bruges handsker for at undgå kvæstelser og snitsår.
- △ Bruserstrålens kontakt med sensitive områder (f.eks. øjne) skal undgås. Der skal være en tilstrækkelig afstand mellem bruseren og kroppen.
- △ Bruseren må kun bruges til at bruse, til hygiejne og rengøring af kroppen.

Monteringsanvisninger

- Den vedlagte smudsfangssi skal indsættes i bruseren for at undgå snavs fra rørsystemet. Indskyllet snavs kan have indflydelse på bruserens funktion og/eller føre til beskadigelser på håndbruserens funktionsdele.
- Før monteringen skal produktet kontrolleres for transportskader. Efter monteringen godkendes transportskader eller skader på overfladen ikke længere.

Tekniske data

Driftstryk:	max. 0,6 MPa
Anbefalet driftstryk: (1 MPa = 10 bar = 147 PSI)	0,1 – 0,4 MPa
Varmtvandstemperatur:	max.60 °C
Termisk desinfektion:	70 °C / max. 4min

Produktet er udelukkende beregnet til drikkevand!

Symbolbeskrivelse

-  **Målene** (se s. 17)
-  **Gennemstrømningsdiagram** (se s. 17)
-  **Brugsanvisning** (se s. 20)
-  **Reserve dele** (se s. 22)
-  **Rengøring** (se s. 21) og vedlagt brochure
-  **Godkendelse** (se s. 19)

**Montering
se s. 19**



! Avisos de segurança

- △ Durante a montagem devem ser utilizadas luvas de protecção, de modo a evitar ferimentos resultantes de entalamentos e de cortes.
- △ Deve-se evitar o contacto dos jactos de água com partes do corpo sensíveis (p. ex. olhos). É necessário manter uma distância suficiente entre o chuveiro e o corpo.
- △ O chuveiro só pode ser utilizado para fins de higiene pessoal.

Avisos de montagem







- O filtro de rede deve ser colocado para proteger o chuveiro de areias e resíduos provenientes da tubagem. Resíduos e areias podem danificar componentes, ou provocar mau funcionamento do chuveiro; as avarias assim provocadas anulam a nossa responsabilidade e anulam a nossa garantia.
- Antes da montagem deve-se controlar o produto relativamente a danos de transporte. Após a montagem não são aceites quaisquer danos de transporte ou de superfície.

Dados Técnicos

Pressão de funcionamento:	max. 0,6 MPa
Pressão de func. recomendada: (1 MPa = 10 bar = 147 PSI)	0,1 – 0,4 MPa
Temperatura da água quente:	max.60 °C
Desinfecção térmica:	70 °C / max. 4min

Este produto foi única e exclusivamente concebido para água potável!

Descrição do símbolo

-  **Medidas** (ver página 17)
-  **Fluxograma** (ver página 17)
-  **Funcionamento** (ver página 20)
-  **Peças de substituição** (ver página 22)
-  **Limpeza** (ver página 21) e brochura em anexo
-  **Marca de controlo** (ver página 19)

**Montagem
ver página 19**



Wskazówki bezpieczeństwa

- △ Aby uniknąć zranień, takich jak zgniecenia czy przecięcia, podczas montażu należy nosić rękawice.
- △ Należy unikać kontaktu strumienia wypływającego z głowicy z wrażliwymi częściami ciała (np. oczami). Należy zachowywać odpowiednią odległość pomiędzy głowicą a ciałem.
- △ Prysznic może być używany tylko do kąpieli, higieny i czyszczenia ciała.

Wskazówki montażowe

- Znajdujące się przy prysznicy sitko musi zostać zainstalowane, aby zatrzymać zanieczyszczenia z instalacji. Przedostające się zanieczyszczenia mogą mieć ujemny wpływ na działanie i/lub prowadzić do usterek w działaniu elementów prysznica. Za powstałe z tego tytułu szkody firma Hansgrohe nie ponosi odpowiedzialności.
- Przed montażem należy skontrolować produkt pod kątem szkód transportowych. Po montażu nie widać żadnych szkód transportowych ani szkód na powierzchni.

Dane techniczne

Ciśnienie robocze:	maks. 0,6 MPa
Zalecane ciśnienie robocze:	0,1 – 0,4 MPa
(1 MPa = 10 bary = 147 PSI)	
Temperatura wody gorącej:	maks. 60°C
Dezynfekcja termiczna:	70°C / maks. 4min

Produkt stworzono wyłącznie do wody pitnej!

Opis symbolu

-  **Wymiary** (patrz strona 17)
-  **Schemat przepływu** (patrz strona 17)
-  **Obsługa** (patrz strona 20)
-  **Części serwisowe** (patrz strona 22)
-  **Czyszczenie** (patrz strona 21) i dołączona broszura
-  **Znak jakości** (patrz strona 19)

Montaż

patrz strona 19



Bezpečnostní pokyny

- △ Pro zabránění řezným zraněním a pohmožděním je nutné při montáži nosit rukavice.
- △ Je nutné zabránit kontaktu vodních paprsků sprchy s měkkými částmi těla (např. očima). Je nutné dodržovat dostatečný odstup mezi sprchou a tělem.
- △ Sprcha smí být používána pouze za účelem koupání a tělesné hygieny.

Pokyny k montáži

- Do přívodu musí být zabudováno se sprchou dodávané sítko, aby zachycovalo nečistoty vyplavené z vodovodní sítě. Vyplavené nečistoty mohou ovlivnit funkci sprchy a nebo mohou vést i k jejímu poškození. Na takto vzniklé škody se nevztahuje záruka firmy Hansgrohe.
- Před montáží je třeba produkt zkontrolovat, zda nebyl při transportu poškozen. Po zabudování nebudou uznány žádné škody způsobené transportem nebo poškození povrchu.

Technické údaje

Provozní tlak:	max. 0,6 MPa
Doporučený provozní tlak:	0,1 – 0,4 MPa
(1 MPa = 10 bar = 147 PSI)	
Teplota horké vody:	max. 60°C
Teplná desinfekce:	70°C / max. 4min

Výrobky Hansgrohe jsou vhodné pro přímý kontakt s pitnou vodou.

Popis symbolů

-  **Rozmíry** (viz strana 17)
-  **Diagram průtoku** (viz strana 17)
-  **Ovládání** (viz strana 20)
-  **Servisní díly** (viz strana 22)
-  **Čištění** (viz strana 21) a přiložená brožura
-  **Zkušební značka** (viz strana 19)

Montáž

viz strona 19



Bezpečnostné pokyny

- △ Pri montáži musíte nosiť rukavice, aby ste predišli pomliaždeninám a rezným poraneniam.
- △ Vyhýbajte sa kontaktu vodného lúča sprchy s citlivými miestami tela (napr. oči). Dodržiavajte dostatočnú vzdialenosť medzi sprchou a telom.
- △ Sprcha sa smie používať len na účely kúpania a telesnej hygieny.

Pokyny pre montáž







- Do prívodu musí byť zabudované so sprchou dodávané sítko, aby zachytilo nečistoty vyplavené z vodovodnej siete. Vyplavené nečistoty môžu ovplyvniť funkciu sprchy, alebo spôsobiť jej poškodenie. Na takto vzniknuté škody sa nevzťahuje záruka firmy Hansgrohe.
- Pred montážou musíte produkt skontrolovať, či nebol počas transportu poškodený. Po zabudovaní nebudú uznané žiadne škody spôsobené transportom alebo poškodenia povrchu.

Technické údaje

Prevádzkový tlak:	max. 0,6 MPa
Doporučený prevádzkový tlak: (1 MPa = 10 bar = 147 PSI)	0,1 – 0,4 MPa
Teplota teplej vody:	max. 60 °C
Termická dezinfekcia:	70 °C / max. 4min

Výrobok je koncipovaný výhradne pre pitnú vodu!

Popis symbolov

-  **Rozmery** (viď strana 17)
-  **Diagram prietoku** (viď strana 17)
-  **Obsluha** (viď strana 20)
-  **Servisné diely** (viď strana 22)
-  **Čistenie** (viď strana 21) a priložená brožúra
-  **Osvedčenie o skúške** (viď strana 19)

安全技巧

- △ 装配时为避免挤压和切割受伤，必须戴上手套。
- △ 必须避免让身体敏感部位（如眼睛）接触到莲蓬头喷水。必须保持莲蓬头与人头之间有足够的距离。
- △ 该莲蓬头仅允许作淋浴、卫生保健和身体清洁目的使用。

安装提示

- 必须装上花洒所附带的滤网密封垫，以过滤管道里的杂质污物。杂质污物会影响花洒的功能和/或损坏花洒的功能部件，由此而产生的产品损坏不属于汉斯格雅的保修范围。
- 安装前必须检查产品是否受到运输损害。安装后将不认可运输损害或表面损伤。

技术参数

工作压力:	最大 0,6 MPa
推荐工作压力:	0,1 0,4 MPa
(1 MPa = 10 bar = 147 PSI)	
热水温度:	最大 60 °C
热力消毒:	70 °C / 最大 4分钟

该产品专为饮用水设计！

符号说明

-  **大小** (参见第 17 页)
-  **流量示意图** (参见第 17 页)
-  **操作** (参见第 20 页)
-  **备用零件** (参见第 22 页)
-  **清洗** (参见第 21 页) 并附有小手册
-  **检验标记** (参见第 19 页)



Montáž
viď strana 19



安装
参见第 19 页



Указания по технике безопасности

-  Во время монтажа следует надеть перчатки во избежание прищемления и порезов.
-  Не допускайте попадания струи воды из разбрызгивателя на чувствительные части тела (например, на глаза). Разбрызгиватель следует устанавливать на достаточном расстоянии от тела.
-  Источник разбрызгивания разрешается использовать только в гигиенических целях для принятия ванны и личной гигиены.

Указания по монтажу

- Для предотвращения попадания частиц грязи из водопроводной сети необходимо установить фильтр, прилагаемый к ручному душу. Частицы грязи могут нарушить отдельные функции и/или привести к повреждению функциональных деталей ручного душа, Hansgrohe не несет ответственность за повреждения вследствие отсутствия фильтра.
- Перед монтажом следует проверить изделие на предмет повреждений при перевозке. После монтажа претензии о возмещении ущерба за повреждения при перевозке или повреждения поверхностей не принимаются.

Технические данные

Рабочее давление: не более, 0,6 МПа
 Рекомендуемое рабочее давление: 0,1 – 0,4 МПа (1 МПа = 10 bar = 147 PSI)
 Температура горячей воды: не более, 60°C
 Термическая дезинфекция: 70°C / не более, 4мин

Изделие предназначено исключительно для питьевой воды!

Описание символов



Размеры (см. стр. 17)



Схема потока (см. стр. 17)



Эксплуатация (см. стр. 20)



Комплект (см. стр. 22)





Очистка (см. стр. 21) и прилагаемая брошюра



Знак технического контроля (см. стр. 19)

Biztonsági utasítások

-  A szerelésnél a zúzódások és vágási sérülések elkerülése érdekében kesztyűt kell viselni.
-  Kerülni kell a zuhanyugár érintkezését érzékeny testrészekkel (pl. szemek). Be kell tartani a megfelelő távolságot a zuhanyfej és a test között.
-  A zuhanyt csak fürdő- higiéniai- és tisztítási célra szabad használni.

Szerelési utasítások

- A kézi zuhanyhoz csomagolt szűrőtömítést be kell szerelni a vízhálózatból származó szennyeződések kiküszöbölésére. A beáramló szennyeződések akadályozhatják és / vagy teljesen tönkre is tehetik a zuhany funkcióit. Az ezekből adódó károokért a Hansgrohe nem felel.
- A szerelés előtt ellenőrizni kell, hogy a terméknek nincs-e szállítási sérülése. Beépítés után a szállítási- vagy felületi sérüléseket nem ismerik el.

Műszaki adatok

Üzemi nyomás: max. 0,6 MPa
 Ajánlott üzemi nyomás: 0,1 – 0,4 MPa
 (1 MPa = 10 bar = 147 PSI)
 Forróvíz hőmérséklet: max. 60°C
 Termikus fertőtlenítés: 70°C / max. 4perc

A terméket kizárólag ivóvízhez tervezték!

Szimbólumok leírása



Méretet (lásd a 17. oldalon)



Átfolyási diagramm (lásd a 17. oldalon)



Használat (lásd a 20. oldalon)



Tartozékok (lásd a 22. oldalon)



Tisztítás (lásd a 21. oldalon) és mellékelt brossúrával



Vizsgajel (lásd a 19. oldalon)

Монтаж

см. стр. 19





Szerelés

lásd a 19. oldalon



Turvallisuusohjeet

-  Asennuksessa on käytettävä käsineitä puristumien ja viltojen aiheuttamien tapaturmien estämiseksi.
-  Suihkuveden kontaktia herkkien ruumiinosien (esim. silmien) kanssa on vältettävä. Suihkun ja vartalon välissä on oltava riittävä väli.
-  Suihkua saa käyttää vain kylpy-, hygienia ja kehonpuhdistustarkoituksiin.

Asennusohjeet

- Käsisuihkun mukana toimitettu sihtitiiviste on asennettava paikalleen, jotta lian huuhtoutuminen vesijohtoverkostosta käsisuihkuun estyy. Huuhtoutuvat likahiukkaset voivat häiritä suihkun toimintaa tai vahingoittaa toimintaosia, Hansgrohe ei vastaa tästä aiheutuneista vahingoista.
- Ennen asennusta on tarkastettava tuotteen mahdolliset kuljetusvahingot. Asennuksen jälkeen kuljetus- ja pintavaurioita ei hyväksytä.

Tekniset tiedot

Käyttöpaine:	maks. 0,6 MPa
Suosittelut käyttöpaine:	0,1 – 0,4 MPa
(1 MPa = 10 bar = 147 PSI)	
Kuuman veden lämpötila:	maks. 60°C
Lämpödesinfektio:	70°C / maks. 4min

Tuote on suunniteltu käytettäväksi ainoastaan juomaveden kanssa!



Merkin kuvaus

-  **Mitat** (katso sivu 17)
-  **Virtausdiagrammi** (katso sivu 17)
-  **Käyttö** (katso sivu 20)
-  **Varaosat** (katso sivu 22)
-  **Puhdistus** (katso sivu 21) ja oheinen esite
-  **Koestusmerkki** (katso sivu 19)

Asennus
katso sivu 19



Säkerhetsanvisningar

-  Handskar ska bäras under monteringsarbetet så att man kan undvika kläm- och skärskadorgen werden.
-  Undvik att rikta duschstrålarna mot känsliga kroppsdelar (t. ex. ögonen. Det måste finnas ett tillräckligt stort avstånd mellan duschen och kroppen.
-  Duschen får bar användas till dusch-, bad- och personlig hygien.

Monteringsanvisningar







- Silpackningen som följer med duschen måste monteras för att undvika att smuts från ledningsnätet tränger in. Smuts som spolats in kan påverka funktionerna och/eller leda till skador på funktionsdelar i duschen. Hansgrohe fränsäger sig allt ansvar för skador som kan härledas till detta.
- Det måste undersökas om produkten har transportskador innan den monteras. Efter monteringen accepteras inga transport- eller ytskittskador.

Tekniska data

Driftstryck:	max. 0,6 MPa
Rek. driftstryck:	0,1 – 0,4 MPa
(1 MPa = 10 bar = 147 PSI)	
Varmvattentemperatur:	maks. 60°C
Termisk desinfektion:	70°C / max. 4min

Produkten är enbart avsedd för dricksvatten!

Symbolförklaring

-  **Måtten** (se sidan 17)
-  **Flödesschema** (se sidan 17)
-  **Hantering** (se sidan 20)
-  **Reservdelar** (se sidan 22)
-  **Rengöring** (se sidan 21) och medföljande broschyr
-  **Testsigill** (se sidan 19)

Montering
se sidan 19



Saugumo technikos nurodymai

- △ Apsaugai nuo užspaudimo ir įsijovimo montavimo metu mūvėkite pirštines.
- △ Būtina vengti dušo vandens srovės kontakto su jautriomis kūno vietomis (pvz., akimis). Todėl būtina laikytis tinkamo atstumo nuo dušo.
- △ Dušo galva naudojama tik maudymosi, higieniniais ir kūno švarinimo tikslais.

Montavimo instrukcija

- Tinklelis, kuris yra rankų dušas pakuotėje, privalo būti įstatytas, kad būtų apsaugota nuo išorės nešvarumų. Nešvarumai gali pakenkti rankų dušas funkcionalumui ir (arba) sugadinti rankų dušas funkcines dalis. Tokiu atveju "Hansgrohe" atsakomybės nepriima.
- Prieš montuojant būtina patikrinti, ar gaminyje nebuvo pažeistas transportavimo metu. Sumontavus pretenzijos dėl transportavimo ir paviršiaus pažeidimų nepriimamos.

Techniniai duomenys

Darbinis slėgis: ne daugiau kaip 0,6 MPa
 Rekomenduojamas slėgis: 0,1 – 0,4 MPa
 (1 MPa = 10 barų = 147 PSI)
 Karšto vandens temperatūra: ne daugiau kaip 60°C
 Terminis dezinfekavimas: 70°C / ne daugiau kaip 4min

Produktas skirtas tik geriamajam vandeniui!

Simbolio aprašymas



Išmatavimai (žr. psl. 17)



Pralaidumo diagrama (žr. psl. 17)



Eksploatacija (žr. psl. 20)



Atsarginės dalys (žr. psl. 22)



Valymas (žr. psl. 21) ir pridama brošiūra



Bandymo pažyma (žr. psl. 19)

Sigurnosne upute

- △ Prilikom montaže se radi sprječavanja prignječjenja i posjekotina moraju nositi rukavice.
- △ Mora se izbjegavati kontakt mlaza iz tuša s osjetljivim dijelovima tijela (npr. očima). Tijelo korisnika mora biti dovoljno udaljeno od tuša.
- △ Tuš se smije primjenjivati samo za kupanje, tuširanje i osobnu higijenu.

Upute za montažu

- Filter potrebno je ugraditi kako bi se regulirao protok vode i smanjio dotok prljavštine. Za eventualna oštećenja uzrokovana prljavštinom proizvođač Hansgrohe nije odgovoran.
- Prije montaže mora se provjeriti je li proizvod oštećen prilikom transporta. Nakon ugradnje se ne priznaju nikakve reklamacije koje se odnose na površinska i transportna oštećenja.

Tehnički podaci

Najveći dopušteni tlak: tlak 0,6 MPa
 Preporučeni tlak: 0,1 – 0,4 MPa
 (1 MPa = 10 bar = 147 PSI)
 Temperatura vruće vode: tlak 60°C
 Termička dezinfekcija: 70°C / tlak 4min

Proizvod je koncipiran isključivo za pitku vodu!

Opis simbola



Mjere (pogledaj stranicu 17)



Dijagram protoka (pogledaj stranicu 17)



Upotreba (pogledaj stranicu 20)



Rezervni djelovi (pogledaj stranicu 22)



Čišćenje (pogledaj stranicu 21) i priložena brošura



Oznaka testiranja (pogledaj stranicu 19)

Montavimas
žr. psl. 19



Sastavljanje
pogledaj stranicu 19



! Güvenlik uyarıları

- △ Montaj esnasında ezilme ve kesilme gibi yaralanmaları önlemek için eldiven kullanılmalıdır.
- △ Püskürtme başlıklarının hassas organlara teması (örn. gözler) önlenmelidir. Püskürtücü ile beden arasında yeterli mesafe bırakılmalıdır.
- △ Su püskürtücü yalnızca banyo, hijyen ve yıkanma amaçları için kullanılabilir.

Montaj açıklamaları

- El duşu kafasına eklenmiş olan süzgeç contası, boru şebekesinden sızan kirlerin önüne geçmek için, yerine monte edilmelidir. İçeri sızan bu kirler duşun fonksiyonunu sekteleyebilir ve/veya duşun fonksiyon parçaları üzerinde hasarlara sebep olabilir, bu yüzden meydana gelen hasarlardan Hansgrohe sorumlu tutulamaz.
- Montaj işleminden önce ürün nakliye hasarları yönünden kontrol edilmelidir. Montaj işleminden sonra nakliye veya yüzey hasarları için sorumluluk üstlenilmemektedir.

Teknik bilgiler

İşletme basıncı:	azami 0,6 MPa
Tavsiye edilen işletme basıncı:	0,1 - 0,4 MPa
(1 MPa = 10 bar = 147 PSI)	
Sıcak su sıcaklığı:	azami 60 °C
Termik dezenfeksiyon:	70 °C / azami 4dak

Ürün sadece şebeke suyu için tasarlanmıştır!

Simge açıklaması



Ölçüleri (Bakınız sayfa 17)



Akış diyagramı (Bakınız sayfa 17)



Kullanımı (Bakınız sayfa 20)



Yedek Parçalar (Bakınız sayfa 22)



Temizleme (Bakınız sayfa 21) ve birlikte verilen broşür



Kontrol işareti (Bakınız sayfa 19)

! Instrucțiuni de siguranță

- △ La montare utilizați mănuși pentru evitarea contuziunilor și tăierii mâinilor.
- △ Evitați contactul jetului de apă cu părțile de corp sensibile (de ex. ochii). Țineți dușul la o distanță corespunzătoare de corp.
- △ Dușul poate fi utilizat doar în scopuri de spălare, igienizare și de întreținere a igienei corporale.

Instrucțiuni de montare

- Montajii garnitura de filtru livrată împreună cu capătul de duș de mână pentru evitarea pătrunderii impurităților din rețeaua de alimentare. Impuritățile pătrunse pot influența funcționarea aparatului și/sau provoca deteriorarea capătului de duș. Garanția nu acoperă aceste daune.
- Înainte de instalare verificați, dacă produsul prezintă deteriorări de transport. După instalare garanția nu acoperă deteriorările de transport și cele de suprafață.

Date tehnice

Presiune de funcționare:	max. 0,6 MPa
Presiune de funcționare recomandată:	0,1 - 0,4 MPa
(1 MPa = 10 bar = 147 PSI)	
Temperatura apei calde:	max. 60 °C
Dezinfecție termică:	70 °C / max. 4min

Produsul este destinat exclusiv pentru apă potabilă.

Descrierea simbolurilor



Dimensiuni (vezi pag. 17)



Diagrama de debit (vezi pag. 17)



Utilizare (vezi pag. 20)



Piese de schimb (vezi pag. 22)



Curățare (vezi pag. 21) și broșura alăturată



Certificat de testare (vezi pag. 19)

Montaj
Bakınız sayfa 19



Montare
vezi pag. 19



Υποδειξεις ασφαλείας

- △ Για να αποφύγετε τραυματισμούς κατά τη συναρμολόγηση πρέπει να φοράτε γάντια.
- △ Η επαφή δέσμης νερού του ντους με ευαίσθητες περιοχές του σώματος (π.χ. μάτια) πρέπει να αποφεύγεται. Διατηρείτε επαρκή απόσταση ανάμεσα στο ντους και το σώμα.
- △ Το ντους επιτρέπεται να χρησιμοποιείται μόνο για το μπάνιο, τον καθαρισμό και την υγιεινή του σώματος.

Οδηγίες συναρμολόγησης

- Πρέπει να εγκατασταθεί το παρέμβυσμα φίλτρου που συνοδεύει τον καταιονιστήρα κατά τέτοιο τρόπο, ώστε να αποφεύγονται ρύποι που προέρχονται από το δίκτυο ύδρευσης. Οι ρύποι από το δίκτυο ύδρευσης μπορούν να επηρεάσουν αρνητικά και/ή να προξενήσουν ζημιά στα λειτουργικά τμήματα του καταιονιστήρα (ντους). Τέτοιου είδους ζημιές δεν καλύπτονται από την εγγύηση Hansgrohe.
- Πριν τη συναρμολόγηση πρέπει να εξεταστεί το προϊόν για ζημιές μεταφοράς. Μετά την εγκατάσταση δεν αναγνωρίζονται ζημιές από τη μεταφορά ή επιφανειακές ζημιές.

Τεχνικά Χαρακτηριστικά

Λειτουργία πίεσης:	έως 0,6 MPa
Συνιστώμενη λειτουργία πίεσης:	0,1 – 0,4 MPa
(1 MPa = 10 bar = 147 PSI)	
Θερμοκρασία ζεστού νερού:	έως 60 °C
Θερμική απολύμανση:	70 °C / έως 4min

Το προϊόν έχει σχεδιαστεί αποκλειστικά για πόσιμο νερό!

Περιγραφή συμβόλων



Διαστάσεις (βλ. σελίδα 17)



Διάγραμμα ροής (βλ. σελίδα 17)



Χειρισμός (βλ. σελίδα 20)



Ανταλλακτικά (βλ. σελίδα 22)



Καθαρισμός (βλ. σελίδα 21) και
συνημμένο φυλλάδιο



Σήμα ελέγχου (βλ. σελίδα 19)

Varnostna opozorila

- △ Lors du montage, porter des gants de protection pour éviter toute blessure par écrasement ou coupure.
- △ Izogibati se je treba stiku prhalnega curka z občutljivimi deli telesa (npr. očmi). Med telesom in prho mora biti vedno zadosten razmik.
- △ Prha se sme uporabljati le z namenom vzdrževanja higiene oziroma umivanja kopalnice in telesa.

Navodila za montažo

- Filter, ki je priložen ročni prhi, je potrebno vgraditi, da prho zaščiti pred umazanijo iz vodovodne napeljave. Umazanija lahko okvari ali poškoduje dele ročne prhe. Za tako nastalo škodo Hansgrohe ne odgovarja.
- Pred montažo je treba izdelek preveriti glede morebitnih transportnih poškodb. Po vgradnji transportne ali površinske poškodbe ne bodo več priznane.

Tehnični podatki

Delovni tlak:	maks. 0,6 MPa
Priporočeni delovni tlak:	0,1 – 0,4 MPa
(1 MPa = 10 bar = 147 PSI)	
Temperatura tople vode:	maks. 60 °C
Termična dezinfekcija:	70 °C / maks. 4min

Proizvod je zasnovan izključno za sanitarno vodo!

Opis simbola



Mere (glejte stran 17)



Diagram pretoka (glejte stran 17)



Upravljanje (glejte stran 20)



Rezervni deli (glejte stran 22)



Čiščenje (glejte stran 21) in
priložena brošura



Preskusni znak (glejte stran 19)



Συναρμολόγηση
βλ. σελίδα 19



Montaža
Glejte stran 19.



Ohutusjuhised

-  Kandke paigaldamisel muljumis- ja löikevigastuste vältimiseks kindaid.
-  Duši veejoad ei tohi kokku puutuda tundlike kehaosadega (nt silmad). Jätke duši ja keha vahele piisav vahe.
-  Dušši tohib kasutada ainult vanniskäimiseks, hügieeniks ja keha pesemiseks.

Paigaldamisjuhised



- Kaitsmaks dušši torust tuleva mustuse eest, on vaja paigaldada dušiga kaasasolev mustusesööel. Sissetulev mustus võib funktsioneerimist kahjustada ja/või rikkuda duši detaile. Sellist tulenevate kahjude eest Hansgrohe ei vastuta.
- Enne paigaldamist tuleb toodet kontrollida transportikahjustuste osas Pärast paigaldamist ei tunnustata enam transporti- või pinnakahjustuste kaebuseid.

Tehnilised andmed

Töörõhk	maks. 0,6 MPa
Soovitatav töörõhk:	0,1 – 0,4 MPa
(1 MPa = 10 baari = 147 PSI)	
Kuuma vee temperatuur:	maks. 60°C
Termiline desinfitatsioon:	70°C / maks. 4min

Toode on ette nähtud eranditult joogivee jaoks!

Drošības norādes

-  Montāžas laikā, lai izvairītos no saspiedumiem un iegriezumiem, nepieciešams nēsāt cimdus.
-  Nepieciešams izvairīties no dušas strūkļas tieša kontakta ar jutīgām ķermeņa daļām (piem., acīm). Nepieciešams ievērot pietiekošu attālumu starp dušu un ķermeni.
-  Dušu drīkst izmantot vienīgi vannošānās, higiēnas un ķermeņa tīrīšanas nolūkiem.

Norādījumi montāžai







- Jāiemonē dušas komplektā esošais filtrs, lai novērstu netīrumu ieplūšanu no ūdens vada. Ieskatotie netīrumi var traucēt dušas funkciju un / vai arī izraisīt rokas dušas daļu bojājumus, par kuriem Hansgrohe nenes atbildību.
- Pirms montāžas nepieciešams pārbaudīt, vai produktam transportēšanas laikā nav radušies bojājumi. Pēc iebūvēšanas bojājumi, kas radušies transportēšanas laikā, vai virsmas bojājumi netiek atzīti.

Tehniskie dati

Darba spiediens:	maks. 0,6 MPa
Ieteicamais darba spiediens:	0,1 – 0,4 MPa
(1 MPa = 10 bar = 147 PSI)	
Karstā ūdens temperatūra:	maks. 60°C
Termiskā dezinfekcija:	70°C / maks. 4min

Izstrādājums ir paredzēts tikai dzeramajam ūdenim!







Sūmbolite kirjeldus

-  **Mõõtude** (vt lk 17)
-  **Läbivooludiagramm** (vt lk 17)
-  **Kasutamine** (vt lk 20)
-  **Varuosad** (vt lk 22)
-  **Puhastamine** (vt lk 21) ja kaasasolev brošüür
-  **Kontrollsertifikaat** (vt lk 19)

Paigaldamine
vt lk 19



Simbolu nozīme

-  **Izmērus** (skat. 17. lpp.)
-  **Caurplūdes diagramma** (skat. 17. lpp.)
-  **Lietošana** (skat. 20. lpp.)
-  **Rezerves daļas** (skat. 22. lpp.)
-  **Tīrīšana** (skat. 21. lpp.) un klāt pievienotais buklets
-  **Pārbaudes zīme** (skat. 19. lpp.)

Montāža
skat. 19. lpp.



Sigurnosne napomene

- Prilikom montaže se radi sprečavanja prignječenja i posekotina moraju nositi rukavice.
- Mora se izbegavati kontakt mlaza iz tuša sa osetljivim delovima tela (npr. očima). Telo korisnika mora biti na dovoljnom odstojanju od tuša.
- Tuš sme da se koristi samo za kupanje, tuširanje i ličnu higijenu.

Instrukcije za montažu

- Obavezno ugradite mrežicu upakovanu s tušem, čime sprečavate ulazak prljavštine iz vodovoda. Prljavština može dovesti do delimičnog ili potpunog oštećenja delova tuša. Za eventualna oštećenja uzrokovana prljavštinom proizvođač Hansgrohe nije odgovoran.
- Pre montaže se mora proveriti da li je proizvod oštećen pri transportu. Nakon ugradnje se ne priznaju nikakve reklamacije koje se odnose na površinska i transportna oštećenja.

Tehnički podaci

Radni pritisak:	maks. 0,6 MPa
Preporučeni radni pritisak: (1 MPa = 10 bar = 147 PSI)	0,1 - 0,4 MPa
Temperatura vruće vode:	maks. 60°C
Termička dezinfekcija:	70°C / maks. 4min

Proizvod je koncipiran isključivo za pijaću vodu!

Opis simbola

-  **Mere** (vidi stranu 17)
-  **Dijagram protoka** (vidi stranu 17)
-  **Rukovanje** (vidi stranu 20)
-  **Rezervni delovi** (vidi stranu 22)
-  **Čišćenje** (vidi stranu 21) i priložena brošura
-  **Ispitni znak** (vidi stranu 19)

Sikkerhetshenvisninger

- Brúk hansker under montasjonen for å unngå klem- og kuttskader.
- Dusjstrålen skal ikke komme i kontakt med ømfintlige kroppsdeler (f.eks. øynene). Overhold en tilstrekkelig avstand mellom dusjen og kroppen.
- Dusjen skal kun brukes for bading, til hygieneformål og til kroppssrengjøring

Montagehenvisninger







- Silpakningen som er levert med dusjen skal bygges inn for å forhindre at smuss spyles inn fra ledningsnettet. Innspylt smuss kan påvirke funksjonen negativt og/eller kan medføre skader på hånddusjens funksjonsdeler. Hansgrohe påtar seg inget ansvar for skader som resulteres av dette.
- Før montasjonen skal produktet sjekkes for transportskader. Etter monteringen aksepteres ikke noen transport- eller overflateskader.

Tekniske data

Driftstrykk	maks. 0,6 MPa
Anbefalt driftstrykk: (1 MPa = 10 bar = 147 PSI)	0,1 - 0,4 MPa
Varmtvannstemperatur	maks. 60°C
Termisk desinfisering:	70°C / maks. 4min

Produktet er utelukkende designet for drikkevann!



Symbolbeskrivelse

-  **Mål** (se side 17)
-  **Gjennomstrømningsdiagram** (se side 17)
-  **Betjening** (se side 20)
-  **Serviceleder** (se side 22)
-  **Rengjøring** (se side 21) og vedlagt brosjyre
-  **Prøvemerket** (se side 19)





Указания за безопасност

-  При монтажа трябва да се носят ръкавици, за да се избегнат наранявания поради притискане или порязване.
-  Трябва да се избягва контакта на струите на разпръсквателя с чувствителни части на тялото (напр. очите). Между разпръсквателя и тялото трябва да се спазва достатъчно разстояние.
-  Позволено е използването на разпръсквателя само за къпане, хигиена и цели на почистване на тялото.

Указания за монтаж







- Опакованото заедно с разпръсквателя уплътнение с цедка трябва да се монтира, за да се избегне натрупване на замърсявания от водопроводната мрежа. Натрупването на замърсявания може да наруши функцията и/или да доведе до увреждания на функционалните части на разпръсквателя, Hansgrohe не носи отговорност за получените се по този начин щети.
- Преди монтажа продуктът трябва да се провери за транспортни щети. След монтажа не се признават транспортни или повърхностни щети.

Технически данни



Работно налягане:	макс. 0,6 МПа
Препоръчително работно налягане:	0,1 – 0,4 МПа (1 МПа = 10 bar = 147 PSI)
Температура на горещата вода:	макс. 60°C
Термична дезинфекция:	70°C / макс. 4мин

Продуктът е разработен само за питейна вода!

Описание на символите

-  **Размери** (вижте стр. 17)
-  **Диаграма на потока** (вижте стр. 17)
-  **Обслужване** (вижте стр. 20)
-  **Сервизни части** (вижте стр. 22)
-  **Почистване** (вижте стр. 21) и приложена брошура
-  **Контролен знак** (вижте стр. 19)

Udhëzime sigurie

-  Për të evituar lëndimet e pickimeve ose të prerjeve gjatë procesit të montimit duhet që të vishni doreza.
-  Kontakti i valëve të dushit me pjesët e ndjeshme të trupit (p.sh. me sytë) duhet që të shmanget. Midis dushit dhe trupit duhet që të mbahet një distancë e mjaftueshme.
-  Dushi duhet të përdoret vetëm për qëllimet e banjave, të higjienës dhe të larjes së trupit.

Udhëzime për montimin







- Sita që i kemi bashkëngjitur spërkatëses duhet përdorur për të evituar thithjen e papastërtive nga rrjeti i ujësjellësit. Ndotjet mund të dëmtojnë pjesë funksionale të spërkatëses. Hansgrohe nuk merr përgjegjësinë për dëmet e shkaktuara në këtë mënyrë.
- Pëpara montimit duhet që produkti të kontrollohet për dëmtime nga transporti. Pas instalimit nuk do të njihet asnjë dëmtim nga transporti ose dëmtim i sipërfaqes.

Të dhëna teknike

Presioni gjatë punës	maks. 0,6 МПа
Presioni i rekomanduar:	0,1 – 0,4 МПа (1 МПа = 10 bar = 147 PSI)
Temperatura e ujit të ngrohtë	maks. 60°C
Dezinfektim Termik:	70°C / maks. 4min

Produkti është projektuar ekskluzivisht për ujë të pijshëm!

Përshkrimi i simbolit

-  **Përmasat** (shih faqen 17)
-  **Diagrami i qarkullimit** (shih faqen 17)
-  **Përdorimi** (shih faqen 20)
-  **Pjesë ndërrimi** (shih faqen 22)
-  **Pastrimi** (shih faqen 21) dhe broshura bashkëngjitur
-  **Shenja e kontrollit** (shih faqen 19)

Монтаж
вижте стр. 19



Montimi
shih faqen 19



⚠️ تنبيهات الأمان

- ⚠️ يجب إرتداء قفازات لليد أثناء التركيب لتجنب حدوث أخطار الإنحشار أو الجروح.
- ⚠️ يجب تجنب حدوث إتصال مباشر بين الماء الخارج من رأس الدش وبين أجزاء الجسم الحساسة (مثل العينين). يجب وجود مسافة كافية بين رأس الدش والجسم.
- ⚠️ يسمح باستخدام الدش فقط لأغراض الإستحمام، والأغراض الصحية، وتنظيف الجسم.

تعليمات التركيب

- يجب إدخال الحلقة الشبكية لحماية الدش اليدوي من الأوساخ التي تحملها شبكة المواسير. حيث تؤدي الأوساخ الواردة إلى حدوث أعطال أو / و قد تتسبب في تلف أجزاء من من الدش، ومثل هذه الأعطال تلغي كافة المطالبات الخاصة بالمسؤولية أو الضمان.
- قبل القيام بعملية التركيب، يجب فحص المنتج للتأكد من خلوه من أية تلفيات ناتجة عن النقل. بعد القيام بعملية التركيب، لن يتم الاعتراف بوجود أية تلفيات سطحية أو تلفيات ناتجة عن عملية النقل.

المواصفات الفنية

- ضغط التشغيل: الحد الأقصى 0,6 ميجاباسكال
 ضغط التشغيل الموصى به: 0,4 – 0,1 ميجاباسكال
 (1 ميجاباسكال = 10 بار = PSI 147)
 درجة حرارة الماء الساخن: الحد الأقصى 60°C
 تعقيم حراري: 70°C / الحد الأقصى 4 الدقيقة

المنتج مخصص فقط لماء الشرب!

وصف الرموز

أبعاد (راجع صفحة 17) 

رسم للصرف (راجع صفحة 17) 

التشغيل (راجع صفحة 20) 

قطع الغيار (راجع صفحة 22) 

التنظيف (راجع صفحة 21) والكتيب المرفق 

شهادة اختبار (راجع صفحة 19) 

التركيب راجع صفحة 19



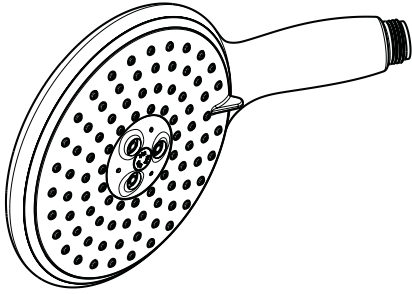

Raindance E 150 AIR 3jet
28551000

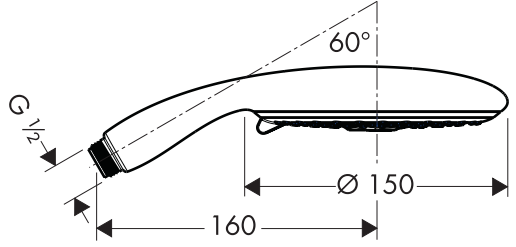

Raindance E 120 AIR 3jet
28549000

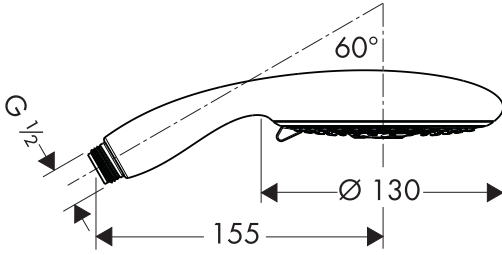

Raindance E 100 AIR 3jet
28553000

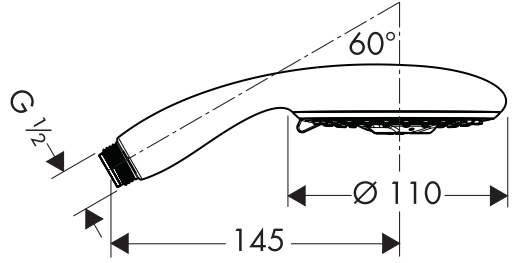

Raindance E 150 AIR 3je 28551000 / **Raindance E 120 AIR 3jet** 28549000
Raindance E 100 AIR 3jet 28553000

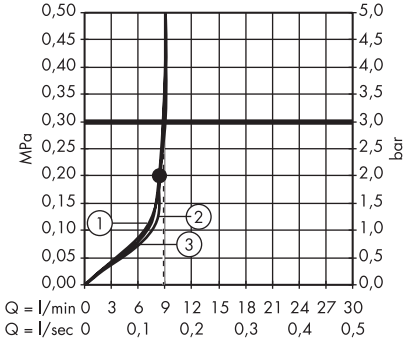

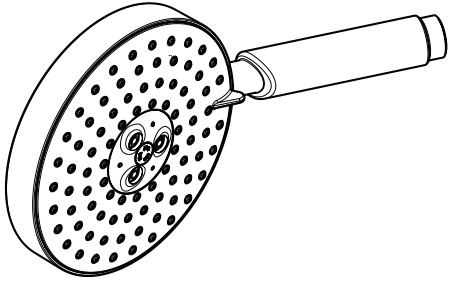

Raindance S 150 AIR 3jet
28550000

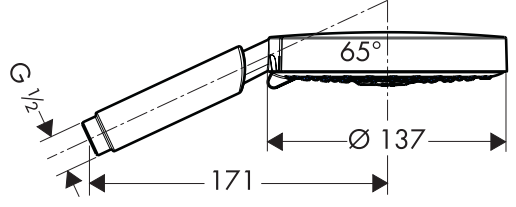

Raindance S 120 AIR 3jet
28554000

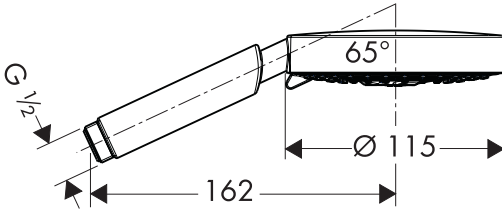

Raindance S 100 AIR 3jet
28552000

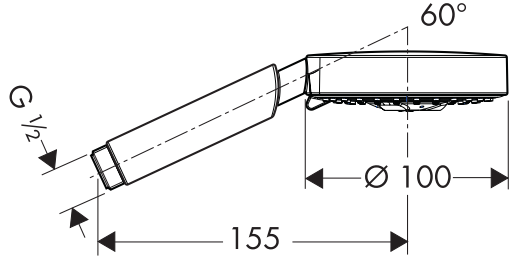

Raindance S 150 AIR 3jet 28550000 / **Raindance S 120 AIR 3jet** 28554000
Raindance S 100 AIR 3jet 28552000

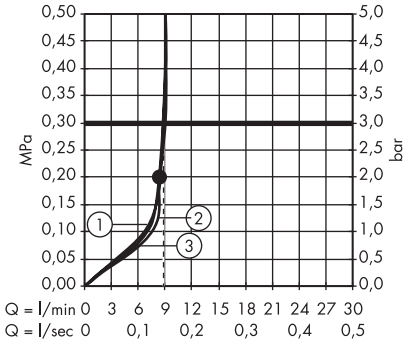



	P-IX	DVGW	SVGW	WRAS	KIWA	NF	ACS	ETA
28549000	P-IX 19534/IZ	CM0348	X				X	
28550000	P-IX 19535/IZ	CM0348	X	X			X	
28551000	P-IX 19535/IZ	CM0348	X	X			X	
28552000	P-IX 19536/IZ	CM0348	X	X			X	
28553000	P-IX 19536/IZ	CM0348	X	X			X	
28554000	P-IX 19534/IZ	CM0348	X				X	

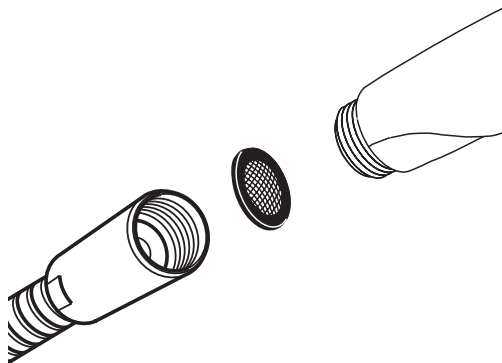

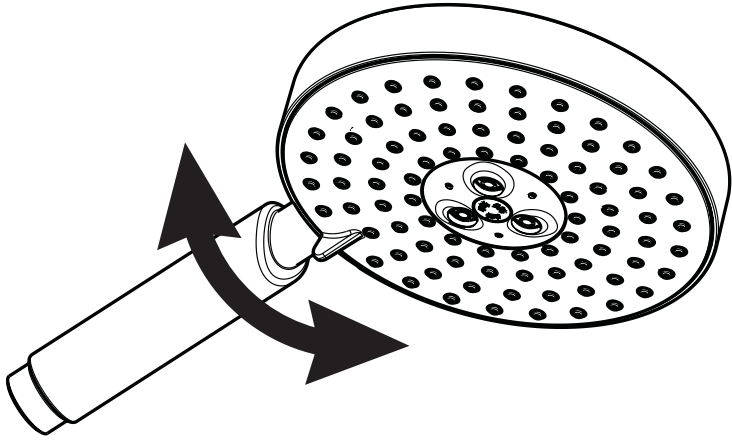

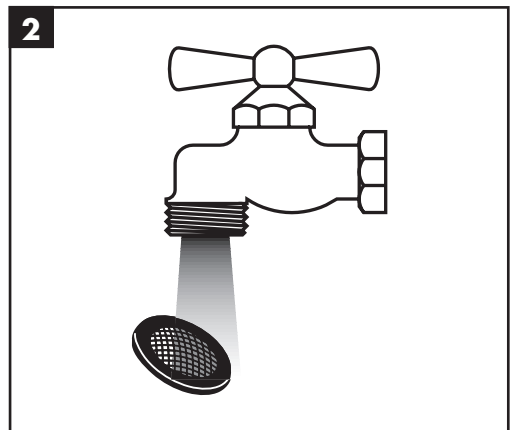
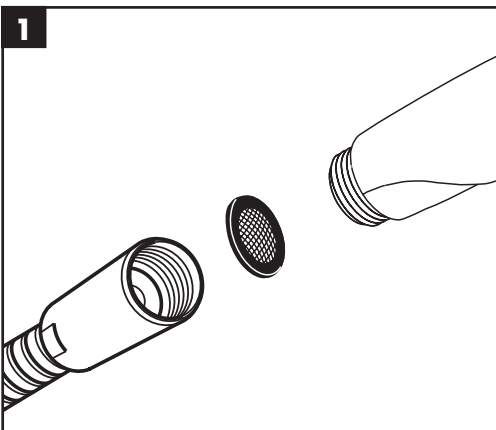
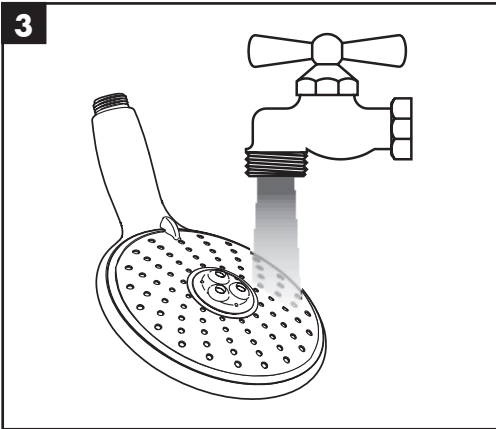
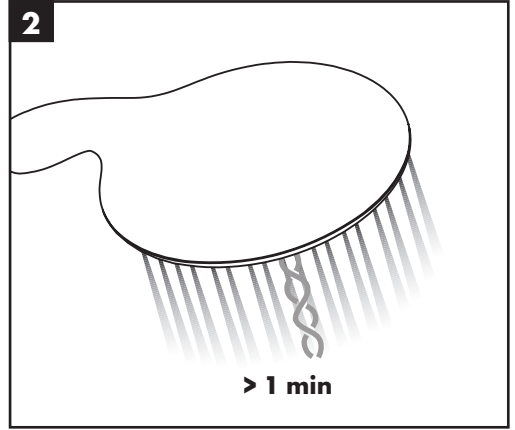
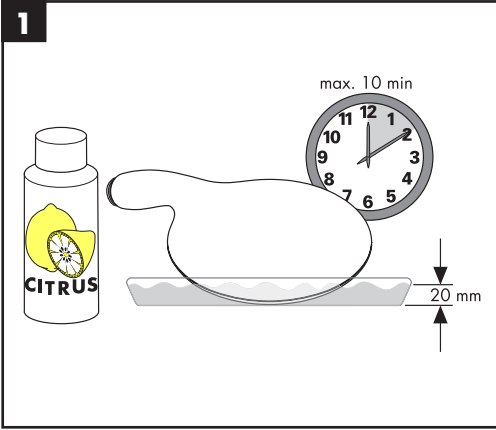

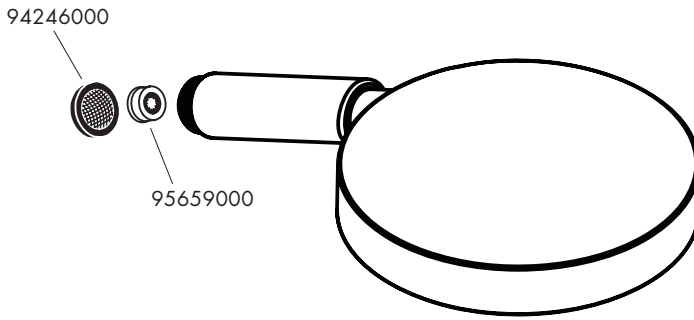
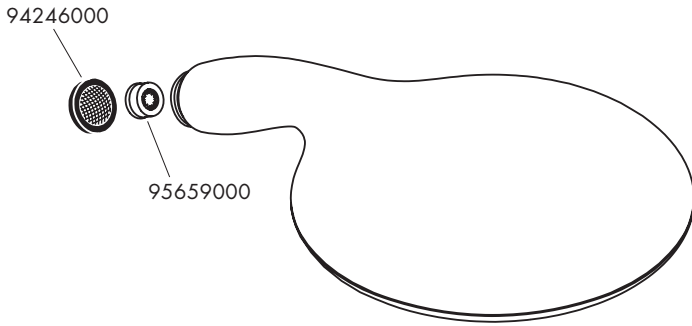

hansgrohe

Hansgrohe - Postfach 1145 · D-77761 Schiltach · Telefon +49 (0) 78 36/51-1282 · Telefax +49 (0) 7836/511440
E-Mail: info@hansgrohe.com · Internet: www.hansgrohe.com

04/2012
9.05961.06