

<b>DE</b>	Gebrauchsanleitung / Montageanleitung	<b>2</b>
<b>FR</b>	Mode d'emploi / Instructions de montage	<b>3</b>
<b>EN</b>	Instructions for use / assembly instructions	<b>4</b>
<b>IT</b>	Istruzioni per l'uso / Istruzioni per Installazione	<b>5</b>
<b>ES</b>	Modo de empleo / Instrucciones de montaje	<b>6</b>
<b>NL</b>	Gebruiksaanwijzing / Handleiding	<b>7</b>
<b>DK</b>	Brugsanvisning / Monteringsvejledning	<b>8</b>
<b>PT</b>	Instruções para uso / Manual de Instalação	<b>9</b>
<b>PL</b>	Instrukcja obsługi / Instrukcja montażu	<b>10</b>
<b>CS</b>	Návod k použití / Montážní návod	<b>11</b>
<b>SK</b>	Návod na použitie / Montážny návod	<b>12</b>
<b>ZH</b>	用户手册 / 组装说明	<b>13</b>
<b>RU</b>	Руководство пользователя / Инструкция по монтажу	<b>14</b>
<b>HU</b>	Használati útmutató / Szerelési útmutató	<b>15</b>
<b>FI</b>	Käyttöohje / Asennusohje	<b>16</b>
<b>SV</b>	Bruksanvisning / Monteringsanvisning	<b>17</b>
<b>LT</b>	Vartotojo instrukcija / Montavimo instrukcijos	<b>18</b>
<b>HR</b>	Upute za uporabu / Uputstva za instalaciju	<b>19</b>
<b>TR</b>	Kullanım kılavuzu / Montaj kılavuzu	<b>20</b>
<b>RO</b>	Manual de utilizare / Instrucțiuni de montare	<b>21</b>
<b>EL</b>	Οδηγίες χρήσης / Οδηγία συναρμολόγησης	<b>22</b>
<b>SL</b>	Navodilo za uporabo / Navodila za montažo	<b>23</b>
<b>ET</b>	Kasutusjuhend / Paigaldusjuhend	<b>24</b>
<b>LV</b>	Lietošanas pamācība / Montāžas instrukcija	<b>25</b>
<b>SR</b>	Uputstvo za upotrebu / Uputstvo za montažu	<b>26</b>
<b>NO</b>	Bruksanvisning / Montasjeveiledning	<b>27</b>
<b>BG</b>	Инструкция за употреба / Ръководство за монтаж	<b>28</b>
<b>SQ</b>	Udhëzuesi i përdorimit / Udhëzime rreth montimit	<b>29</b>
<b>AR</b>	دليل الاستخدام / تعليمات التجميع	<b>30</b>

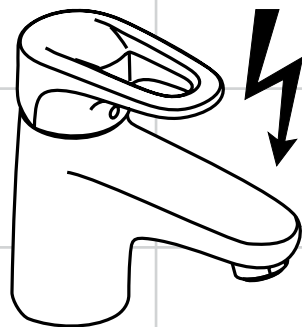

**Metropol E**  
14075XXX



**Ihr Online-Fachhändler für:**

**hansgrohe**

- Kostenlose und individuelle Beratung
- Hochwertige Produkte
- Kostenloser und schneller Versand

- TOP Bewertungen
- Exzelerter Kundenservice
- Über 20 Jahre Erfahrung



**E-Mail: [info@unidomo.de](mailto:info@unidomo.de) | Tel.: 04621 - 30 60 89 0 | [www.unidomo.de](http://www.unidomo.de)**



## Sicherheitshinweise

- Bei der Montage müssen zur Vermeidung von Quetsch- und Schnittverletzungen Handschuhe getragen werden.
- Bei 5 Liter Geräten darf die Auslaufleistung am Mischer 5 l/min nicht übersteigen. Gegebenenfalls Wasserzufuhr am Eckventil regulieren.

## Montagehinweise

- Die Armatur muss nach den gültigen Normen montiert, gespült und geprüft werden!
- Kunststoffschlauch, falls notwendig, gemäß Tabelle kürzen und in das kurze, blau markierte Rohr bis zum Bund einschieben.

## Technische Daten

Betriebsdruck:	max. 1 MPa
Empfohlener Betriebsdruck:	0,1 - 0,5 MPa
Prüfdruck:	1,6 MPa
(1 MPa = 10 bar = 147 PSI)	
Heißwassertemperatur:	max. 80 °C
Empfohlene Heißwassertemperatur:	65 °C
Durchflussleistung:	max. 5 l/min

## Symbolerklärung



Kein essigsäurehaltiges Silikon verwenden!



**Reinigung**  
siehe beiliegende Broschüre.



**Maße** (siehe Seite 33)



**Bedienung** (siehe Seite 34)  
Beim Aufheizen des Wasserspeichers tritt am Auslauf Tropfwasser aus.



**Prüfzeichen** (siehe Seite 34)



**Serviceteile** (siehe Seite 35)  
Wird der Strahlformer gewechselt, muss ein für diese Armatur zugelassener Strahlformer verwendet werden.

## Sonderzubehör



Montageschlüssel (58085000) nicht im Lieferumfang enthalten



Installationskit nicht im Lieferumfang enthalten

## Tabelle über die zu verwendenden Drosselschlauchlängen

Höchstmöglicher Wasserdruck am Verwendungsort in MPa	Geräteinhalt	
	8, 10 und 15 Liter	bis 5 Liter
0,1 - 0,15	ohne Drosselschlauch	Drosselschlauch auf 90 mm gekürzt
0,2 - 0,3	Drosselschlauch auf 90 mm gekürzt	Drosselschlauch unverändert
0,4 - 0,7	Drosselschlauch unverändert Durchflussmenge am Eckventil einregulieren	

Bei einem Ruhedruck über 0,5 MPa muss ein Druckminderer eingebaut werden.



Störung	Ursache	Abhilfe
Wenig Wasser	- Strahlformer verkalkt, verschmutzt	- Strahlformer reinigen, ggf. austauschen
Armatur schwergängig	- Kartusche defekt, verkalkt	- Kartusche austauschen
Armatur tropft ständig bei ausgeschaltetem Wasserbereiter	- Kartusche defekt	- Kartusche austauschen



## Montage siehe Seite 31



## Consignes de sécurité

-  Lors du montage, porter des gants de protection pour éviter toute blessure par écrasement ou coupure.
-  Sur les chauffe-eau à contenance de 5 litres le débit ne doit pas dépasser 5l/min, dans ce cas là, réduire le débit avec le robinet d'arrêt et d'équerre.

## Instructions pour le montage

- La robinetterie doit être installée, rincée et contrôlée conformément aux normes valables!
- Raccourcir éventuellement selon les indications du tableau ci-dessous le tube platique et l'enfoncer jusqu'à la butée dans la tubulure courte avec repère bleu.

## Informations techniques

Pression de service autorisée:	max. 1 MPa
Pression de service conseillée:	0,1 - 0,5 MPa
Pression maximum de contrôle:	1,6 MPa
(1 MPa = 10 bar = 147 PSI)	
Température d'eau chaude:	max. 80 °C
Température recommandée:	65 °C
Débit:	max. 5 l/min

## Description du symbole



Ne pas utiliser de silicone contenant de l'acide acétique!



### Nettoyage

voir la brochure ci-jointe.



### Dimensions (voir page 33)



### Instructions de service (voir page 34)

Le mitigeur goutte lorsque le chauffe-eau monte en température.



### Classification acoustique et débit (voir page 34)



### Pièces détachées (voir pages 35)

Si l'on change le aérateur, il faudra utiliser un aérateur normalisé pour cette robinetterie.



### Accessoires en option

clé de montage (58085000) ne fait pas partie de la fourniture



Mastic d'installation ne fait pas partie de la fourniture

## Tableau relatif aux longueurs de tube d'étranglement à utiliser

Pression d'eau maxi possible en MPa sur le lieu d'utilisation	Contenu de l'appareil	
	8, 10 et 15 litres	jusqu'à 5 litres
0,1 - 0,15	sans tube d'étranglement	Tube d'étranglement raccourci à 90 mm
0,2 - 0,3	Tube d'étranglement raccourci à 90 mm	Tube d'étranglement pas modifié
0,4 - 0,7	Tube d'étranglement pas modifié Régler le débit au niveau du robinet d'équerre	

Incorporer un réducteur de pression si la pression est supérieure à 0,5 MPa.

## Dysfonctionnement

## Origine

## Solution

Pas assez d'eau

- Mousseur entartré ou encrassé

- Nettoyer le mousseur ou le changer éventuellement

Dureté de fonctionnement

- Cartouche défectueuse, entartrée

- Changer la cartouche

Le mitigeur goutte sans arrêt avec un chauffe-eau hors-service

- Cartouche défectueuse



- Changer la cartouche



## Montage voir page 31



## Safety Notes

-  Gloves should be worn during installation to prevent crushing and cutting injuries.
-  With water heaters of 5 liters the flow rate at the mixer should not exceed 5 l/min.
-  In this case the flow rate must be reduced at the isolation valve.

## Installation Instructions

- The fitting must be installed, flushed and tested after the valid norms!
- If necessary shorten plastic hose according to the table and insert it up to the collar into the shorter blue marked copper pipe.

## Technical Data

Operating pressure:	max. 1 MPa
Recommended operating pressure:	0,1 - 0,5 MPa
Test pressure:	1,6 MPa
(1 MPa = 10 bar = 147 PSI)	
Hot water temperature:	max. 80 °C
Recommended hot water temp.:	65 °C
Rate of flow:	max. 5 l/min

## Symbol description



Do not use silicone containing acetic acid!



### Cleaning

see enclosed brochure.



### Dimensions (see page 33)



### Operation (see page 34)

When the storage tank is being heated, the spout will drip.



### Test certificate (see page 34)



### Spare parts (see page 35)

When changing the spray former, it is imperative to use one made for this type of mixer.

### Special accessories

special tool (58085000) order as an extra



Installation putty order as an extra



**Table for the throttle hose lengths to be used**

Highest possible water pressure at user's site in Mpa	Device content	
	8, 10 and 15 liters	up to 5 liters
0,1 - 0,15	without throttle hose	Throttle hose shortened to 90 mm
0,2 - 0,3	Throttle hose shortened to 90 mm	Throttle hose unchanged
0,4 - 0,7	Throttle hose unchanged Adjust flow volume at corner valve	

If the water pressure is greater than 0,5 MPa, fit a pressure reducing valve.



Fault	Cause	Remedy
Insufficient water	- Spray former calcified, dirty	- Clean spray former, exchanging if necessary
Mixer stiff	- Cartridge defective, calcified	- Exchange cartridge
Mixer dripping constantly with water heater switched off	- Cartridge defective	- Exchange cartridge



**Assembly see page 31**



## **Indicazioni sulla sicurezza**

-  Durante il montaggio, per evitare ferite da schiacciamento e da taglio bisogna indossare guanti protettivi.
-  Nel caso di apparecchi da 5 litri l'erogazione del miscelatore non deve superare i 5 l/min. Eventualmente strozzare l'alimentazione d'acqua del rubinetto a squadra.

## **Istruzioni per il montaggio**

- La rubinetteria deve essere installata, pulita e testata secondo le istruzioni riportate!
- Se necessario, tagliare il flessibile in plastica secondo la tabella e introdurlo sino allo spallamento nel tubo corto contrassegnato in blu.

## **Dati tecnici**

Pressione d'uso:	max. 1 MPa
Pressione d'uso consigliata:	0,1 - 0,5 MPa
Pressione di prova:	1,6 MPa
(1 MPa = 10 bar = 147 PSI)	
Temperatura dell'acqua calda:	max. 80 °C
Temp. dell'acqua calda consigliata:	65 °C
Portata di erogazione:	max. 5 l/min

## **Descrizione simbolo**



Non utilizzare silicone contenente acido acetico!



**Pulitura**  
vedi il prospetto accluso.



**Ingombri** (vedi pagg. 33)



**Procedura** (vedi pagg. 34)

Durante il riscaldamento del serbatoio d'acqua all'uscita si ha uno stillicidio.



**Segno di verifica** (vedi pagg. 34)



**Parti di ricambio** (vedi pagg. 35)

Se si cambia il rompighetto, per questo rubinetto deve venir usato un rompighetto idoneo.

## **Accessori speciali**



chiave per montaggio (58085000) non contenuto nel volume di fornitura



Mastice d'installazione non contenuto nel volume di fornitura

## **Tabella delle lunghezze dei tubi di strozzamento applicabili**

Massima pressione d'acqua sul posto espressa in MPa	Contenuto dell'apparecchio	
	8, 10 e 15 litri	fino a 5 litri
0,1 - 0,15	senza tubo di strozzamento	Tubo di strozzamento ridotto a 90 mm
0,2 - 0,3	Tubo di strozzamento ridotto a 90 mm	Tubo di strozzamento non modificato
0,4 - 0,7	Tubo di strozzamento non modificato Regolare la portata tramite la valvola ad angolo	

In caso di una pressione di flusso superiore a 0,2 MPa, si deve installare un riduttore sul tubo principale.

<b>Problema</b>	<b>Possibile causa</b>	<b>Remedio</b>
Scarsità d'acqua	- diffusore del getto difettosa, pieno di calcare	- Pulire oppure sostituire il diffusore del getto
Miscelatore duro	- Cartuccia difettosa	- Sostituire la cartuccia
Il miscelatore perde acqua di continuo con la caldaia spenta	- Cartuccia difettosa	- Sostituire la cartuccia



## **Montaggio vedi pagg. 31**



## Indicaciones de seguridad

- ⚠ Durante el montaje deben utilizarse guantes para evitar heridas por aplastamiento o corte.
- ⚠ En caso de utilizar un calentador de 5 litros de capacidad el caudal de agua que pasa por el mezclador, no debe superar 5 l/min. En caso necesario, disminuir la entrada del agua por medio de la llave de escuadra.

## Indicaciones para el montaje

- El grifo tiene que ser instalado, probado y testado, según las normas en vigor.
- En caso necesario, cortar el tubo plástico como indicado en el esquema e introducir el mismo hasta el collarín en el caño corto marcado azul.

## Datos técnicos

Presión en servicio:	max. 1 MPa
Presión recomendada en servicio:	0,1 - 0,5 MPa
Presión de prueba:	1,6 MPa
(1 MPa = 10 bar = 147 PSI)	
Temperatura del agua caliente:	max. 80 °C
Temp. recomendada del agua caliente:	65 °C
Caudal máximo:	max. 5 l/min

## Descripción de símbolos



No utilizar silicona que contiene ácido acético!



**Limpiar**  
ver el folleto adjunto.



**Dimensiones** (ver página 33)



**Manejo** (ver página 34)

Al calentar el depósito de agua suelen desbordarse de la salida siempre unas gotas de agua.



**Marca de verificación**  
(ver página 34)



**Repuestos** (ver página 35)

En caso de cambiar el aireador, hay que utilizar un aireador adecuado para este tipo de grifería.

## Opcional



Llave de montaje (58085000) no incluido en el suministro



Masilla no incluido en el suministro

## Tabla para el largo de la manguera de estrangulación aplicable

Presión de agua más alta posible en el lugar de aplicación en Mpa	Contenido del equipo	
	8,10 y 15 litros	hasta 5 litros
0,1 - 0,15	sin manguera de estrangulación	Manguera de estrangulación reducida a 90 mm
0,2 - 0,3	Manguera de estrangulación reducida a 90 mm	Manguera de estrangulación no modificada
0,4 - 0,7	Manguera de estrangulación no modificada Regulado de la cantidad de flujo en la válvula de esquina	

En condiciones de presión de reposo superior a 0,5 MPa, es imprescindible montar un reductor de presión.



Problema	Causa	Solución
Sale poca agua	- Formador de chorro ensuciado, calcificado	- Limpiar o cambiar el formador de chorro
Manecilla va dura	- cartucho dañado	- cambiar el cartucho
Grifo pierde continuamente agua con calientaguas apagado	- cartucho dañado	- cambiar el cartucho



## Montaje ver página 31



## Veiligheidsinstructies

-  Bij de montage moeten ter voorkoming van kniel- en snijwonden handschoenen worden gedragen.
-  Bij toestellen van 5 liter mag de uitloopcapaciteit aan de mengkraan niet hoger zijn dan 5 l/min. Indien nodig moet de watertoevoer aan de hoekstopkraan geregeld worden.

## Montage-instructies

- Leidingen doorspoelen volgens Norm. De mengkraan vervolgens monteren en controleren!
- Kunststofslang, indien nodig, volgens tabel verkorten en tot aan de kraag in de korte, blauw gemarkeerde buis schuiven.

## Technische gegevens

Werkdruk: max.	max. 1 MPa
Aanbevolen werkdruk:	0,1 - 0,5 MPa
Getest bij:	1,6 MPa
(1 MPa = 10 bar = 147 PSI)	
Temperatuur warm water:	max. 80 °C
Aanbevolen warm water temp.:	65 °C
Doorstroomcapaciteit:	max. 5 l/min

## Symboolbeschrijving



Gebruik geen zuurhoudende siliconen!



**Reinigen**  
zie bijgevoegde brochure.



**Maten** (zie blz. 33)



**Bediening** (zie blz. 34)

Bij het opwarmen van het waterreservoir ontsnapt aan de uitloop drupwater.



**Keurmerk** (zie blz. 34)



**Service onderdelen** (zie blz. 35)

Indien de straalvormer vervangen wordt, moet een straalvormer gebruikt worden die is toegelaten voor deze armatuur.

## Toebehoren



montagesleutel (58085000) behoort niet tot het leveringspakket



Kit behoort niet tot het leveringspakket

## Tabel van de te gebruiken reduceerslanglengten

Maximale waterdruk op de gebruiksplaats in MPa	Inhoud van het toestel	
	8, 10 en 15 liter	tot 5 liter
0,1 - 0,15	zonder reduceerslang	Reduceerslang verkort tot 90 mm
0,2 - 0,3	Reduceerslang verkort tot 90 mm	Reduceerslang onveranderd
0,4 - 0,7	Reduceerslang onveranderd Debiet instellen aan het hoekventiel	

Bij een statische druk van meer dan 0,5 MPa moet een drukregelaar ingebouwd worden.

Storing	Oorzaak	Oplossing
Weinig water	- Straalopeningen verkalkt, vuil	- Straalopeningen reinigen, indien nodig vervangen
Bediening zwaar	- Kardoes defect of verkalkt	- Kardoes uitwisselen
Armatuur drupt altijd bij een uitgeschakelde boiler	- Kardoes defect	- Kardoes uitwisselen



**Montage zie blz. 31**





## Sikkerhedsanvisninger

- △ Ved monteringen skal der bruges handsker for at undgå kvæstelser og snitsår.
- △ Ved 5 litres beholdere må udløbsydelsen ved håndvaskarmaturet ikke overstige 5 liter/min. I modsat fald drosles vandet ved vandtilførslen ved hjørneventilen.

## Monteringsanvisninger

- Ifølge gældende regler, skal armaturet monteres, skylles igennem og afprøves.
- Plastslange afkortes i henhold til tabellen og skubbes ind til bundet i det blåfarvede rør.

## Tekniske data

Driftstryk:	max. 1 MPa
Anbefalet driftstryk:	0,1 - 0,5 MPa
Prøvetryk:	1,6 MPa
(1 MPa = 10 bar = 147 PSI)	
Varmtvandstemperatur:	max. 80 °C
Anbefalet varmtvandstemperatur:	65 °C
Gennemstrømningskapacitet:	max. 5 l/min

## Symbolbeskrivelse



Der må ikke benyttes eddikesyreholdig silikone!



**Rengøring**  
se venligst den vedlagte brochure.



**Målene** (se s. 33)



**Brugsanvisning** (se s. 34)  
Ved opvarmning af varmtvandsbeholderen forekommer dryp fra udløbstudten.



**Godkendelse** (zie blz. 34)



**Reserve dele** (se s. 35)  
Ved skift af stråleformerer, skal der anvendes en stråleformer, som er godkendt til dette armatur

## Specialtilbehør



Monteringsnøgle (58085000) ikke med i leveringsomfang



Kitt ikke med i leveringsomfang

**Tabel over de drosselslangelængder, som skal bruges**

Højest muligt vandtryk på brugsstedet i MPa	Enhedens indhold	
	8, 10 og 15 liter	op til 5 liter
0,1 - 0,15	uden drosselslange	Drosselslange afkortet til 90 mm
0,2 - 0,3	Drosselslange afkortet til 90 mm	Drosselslange uforandret
0,4 - 0,7	Drosselslange uforandret Juster gennemstrømningsmængden på hjørneventilen	

Ved et rørtryk på mere end 0,5 MPa, skal trykket reduceres.

Fejl	Årsag	Hjælp
For lidt vand	- Stråleformer forkalket, tilsmudset	- Stråleformer renses, skiftes i givet fald ud
Grebet går trægt	- Kartusche defekt, tilkalket	- Udskift kartusche
Armatur drypper hele tiden ved slukket vandvarmer	- Defekt kartusche	- Udskift kartusche





## Avisos de segurança

- ⚠ Durante a montagem devem ser utilizadas luvas de protecção, de modo a evitar ferimentos resultantes de entalamentos e de cortes.
- ⚠ Nos aparelhos de 5 litros a capacidade de saída na misturadora não pode exceder 5 l/min. Regular eventualmente a alimentação da água na torneira de esquadria.

## Avisos de montagem

- A misturadora deve ser instalada, purgada e testada de acordo com as normas em vigor!
- Cortar o tubo flexível em plástico, se necessário, segundo a tabela e inserir no tubo curto com marca azul até à união.

## Dados Técnicos

Pressão de funcionamento:	max. 1 MPa
Pressão de func. recomendada:	0,1 - 0,5 MPa
Pressão testada:	1,6 MPa
(1 MPa = 10 bar = 147 PSI)	
Temperatura da água quente:	max. 80 °C
Temp. água quente recomendada:	65 °C
Caudal:	max. 5 l/min

## Descrição do símbolo

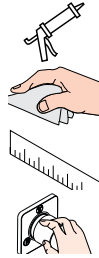

Não utilizar silicone que contenha ácido acético!

**Limpeza**  
consultar a seguinte brochura.

**Medidas** (ver página 33)

**Funcionamento** (ver página 34)  
Fuga de gotas de água durante o aquecimento do depósito de água.



**Marca de controlo**  
(ver página 34)

**Peças de substituição**  
(ver página 35)

Se o emulsor for substituído é necessário utilizar um emulsor adequado para esta torneira.

## Acessórios especiais



Chave especial (58085000) não incluído no volume de fornecimento

Mástique não incluído no volume de fornecimento

## Tabela sobre o comprimento das mangueiras de estrangulamento a utilizar

Maior pressão de água possível no local de aplicação, em MPa	Conteúdo do aparelho	
	8, 10 e 15 litros	até 5 litros
0,1 - 0,15	sem mangueira de estrangulamento	Mangueira de estrangulamento encurtada em 90 mm
0,2 - 0,3	Mangueira de estrangulamento encurtada em 90 mm	Mangueira de estrangulamento inalterada
0,4 - 0,7	Mangueira de estrangulamento inalterada Regular o caudal volumétrico na válvula de canto	

Se a pressão da água for superior a 0,5 MPa é necessário montar um redutor de pressão.

Falha	Causa	Solução
Água insuficiente	- Emulsor com calcário, com sujidade	- Limpar emulsor, event. Substituir
Misturadora perra	- Cartucho defeituoso, calcificado	- Substituir o cartucho
Misturadora pinga constantemente com preparador de água desligado	- Cartucho defeituoso	- Substituir o cartucho





## Wskazówki bezpieczeństwa

- △ Aby uniknąć zranień, takich jak zgniecenia czy przecięcia, podczas montażu należy nosić rękawice.
- △ Przy urządzeniach 5-litrowych wydajność mieszacza nie może przekraczać 5 l/min. W razie potrzeby wyregulować dopływ wody przy zaworku kątowym.

## Wskazówki montażowe

- Armatura musi być zamontowana, przepłukana i wypróbowana według obowiązujących norm!
- Jeżeli to konieczne, przyciąć wąż z tworzywa sztucznego zgodnie z tabelą i wsunąć aż do oporu do krótkiej niebieskiej rury.

## Dane techniczne

Ciśnienie robocze:	maks. 1 MPa
Zalecane ciśnienie robocze:	0,1 - 0,5 MPa
Ciśnienie próbne:	1,6 MPa
(1 MPa = 10 bary = 147 PSI)	
Temperatura wody gorącej:	maks. 80 °C
Zalecana temperatura wody gorącej:	65 °C
Wydajność przepływu:	maks. 5 l/min

## Opis symbolu



Nie stosować silikonów zawierających kwas octowy!



**Czyszczenie**  
patrz dołączona broszura.



**Wymiary** (patrz strona 33)



**Obsługa** (patrz strona 34)  
Przy podgrzaniu zbiornika wody przy wylocie kapie woda.



**Znak jakości** (patrz strona 34)



**Części serwisowe**  
(patrz strona 35)

Przy wymianie kształtownika przepływu należy użyć takiego kształtownika przepływu, którego użycie jest autoryzowane dla danego typu armatury.

### Wyposażenie specjalne

Klucz montażowy (58085000) Nie jest częścią dostawy

Kit instalatorski Nie jest częścią dostawy



## Tabela zawierająca informacje o stosowanych długościach węży dławiących

Maksymalne możliwe ciśnienie wody w miejscu zastosowania w MPa	Zawartość urządzenia	
	8, 10 i 15 litrów	do 5 litrów
0,1 - 0,15	bez węża dławiącego	wąż dławiący skrócony do 90 mm
0,2 - 0,3	wąż dławiący skrócony do 90 mm	wąż dławiący bez zmian
0,4 - 0,7	wąż dławiący bez zmian wyregulować natężenie przepływu na zaworze kątowym	

Przy ciśnieniu przy zamkniętych rurkach wynoszącym 0,5 MPa należy wbudować reduktor ciśnienia.

### Usterka

### Przyczyna

### Pomoc

Mała ilość wody

- Kształtownik przepływu zakamieniony, zabrudzony

- Wyczyścić lub wymienić kształtownik przepływu

Uchwyt armatury pracuje z wysiłkiem

- Uszkodzony wkład, zakamieniony

- Wymiana wkładu

Armatura cieknie zawsze przy wyłączonym podgrzewaczu wody

- Uszkodzony wkład



- Wymiana wkładu



## Montaż patrz strona 31



## **Bezpečnostní pokyny**

-  Pro zabránění řezným zraněním a pohmožděninám je nutné při montáži nosit rukavice.
-  U 5litrových přístrojů nesmí výkon výtoku na mísici baterii překročit 5 l/min. Případně je nutno regulovat přívod vody na rohovém ventilu.

## **Pokyny k montáži**

- Armatura se musí montovat, proplachovat a testovat podle platných norem!
- Je-li zapotřebí, zkrátit plastovou hadici podle tabulky a zasunout až po okraj do krátké, modře označené trubky.

## **Technické údaje**

Provozní tlak:	max. 1 MPa
Doporučený provozní tlak:	0,1 - 0,5 MPa
Zkušební tlak:	1,6 MPa
(1 MPa = 10 bar = 147 PSI)	
Teplota horké vody:	max. 80 °C
Doporučená teplota horké vody:	65 °C
Průtok:	max. 5 l/min

## **Popis symbolů**



Nepoužívat silikon s obsahem kyseliny octové!



### **Čištění**

viz přiložená brožura.



### **Rozměry** (viz strana 33)



### **Ovládání** (viz strana 34)

Při zahřívání bojleru vystupují na výtoku kapky vody.



### **Zkušební značka** (viz strana 34)



### **Servisní díly** (viz strana 35)

Je-li nutná výměna tvarovače proudu, pak se musí použít tvarovač, který je pro tuto amaturu povolen.

### **Zvláštní příslušenství**

montážní klíč (58085000) není součástí dodávky

Instalační kit není součástí dodávky



## **Tabulka k délkám elastických hadic, které je třeba použít.**

Nejvyšší možný tlak vody v místě použití v MPa	Objem přístrojů	
	8, 10 a 15 litrů	do 5 litrů
0,1 - 0,15	bez elastické hadice	Elastická hadice zkrácena na 90 mm
0,2 - 0,3	Elastická hadice zkrácena na 90 mm	Elastická hadice bez úprav
0,4 - 0,7	Elastická hadice bez úprav naregulujte průtokové množství na rohovém ventilu	

Při klidovém tlaku nad 0,5 MPa se musí zabudovat omezovač tlaku

<b>Porucha</b>	<b>Příčina</b>	<b>Odstranění</b>
Málo vody	- tvarovač proudu zanesen vodním kamenem, znečištěn	- vyčistit, popř. vyměnit tvarovač proudu
Armatura jde ztěžka	- Kartuše je vadná, zanesená vodním kamenem	- Kartuši vyměnit
z armatury odkapává stále voda i když je ohřívač vody vypnut	- Kartuše je vadná	- Kartuši vyměnit



## **Montáž viz strana 31**



## Bezpečnostné pokyny

- ⚠ Pri montáži musíte nosiť rukavice, aby ste predišli pomliaždeninám a rezným poraneniam.
- ⚠ U 5 l ohrievačov vody nesmie prietok batérie prekročiť 5l/min. Prípadne nastavte prívod vody pomocou uzatváracieho ventilu.

## Pokyny pre montáž

- Batéria sa musí montovať, preplachovať a testovať podľa platných noriem!
- V prípade potreby skráťte plastovú hadicu podľa tabuľky a nasuňte do krátkej, modrej označenej rúrky až po spoj.

## Technické údaje

Prevádzkový tlak:	max. 1 MPa
Doporučený prevádzkový tlak:	0,1 - 0,5 MPa
Skúšobný tlak:	1,6 MPa
(1 MPa = 10 bar = 147 PSI)	
Teplota teplej vody:	max. 80 °C
Doporučená teplota teplej vody:	65 °C
Prietok:	max. 5 l/min

## Popis symbolov



Nepoužívať silikón s obsahom kyseliny octovej!



### Čistenie

nájdete v priloženej brožúre.



### Rozmery (viď strana 33)



### Obsluha (viď strana 34)

Pri ohreve nádrže na vodu kvapká z odpadu voda.



### Osvedčenie o skúške

(viď strana 34)



### Servisné diely (viď strana 35)

Pri výmene tvarovača prúdu sa musí použiť tvarovač prípustný pre túto batériu.

### Zvláštne príslušenstvo

montážny kľúč (58085000) nie je súčasťou dodávky



Inštalčná súprava nie je súčasťou dodávky



## Tabuľka dĺžok elastických hadíc, ktoré je treba použiť

Najvyšší možný tlak vody v mieste použitia v MPa	Objem zariadenia	
	8, 10 a 15 litrov	do 5 litrov
0,1 - 0,15	bez elastickej hadice	Elastická hadica, skrátená na 90 mm
0,2 - 0,3	Elastická hadica, skrátená na 90 mm	Elastická hadica bez úprav
0,4 - 0,7	Elastická hadica bez úprav nastavte prietok na rohovom ventilu	

Ak je tlak vody viac ako 0,5 MPa, je nutné namontovať tlakový redukčný ventil.

Porucha	Príčina	Pomoc
Málo vody	- Tvarovač prúdu znečistený vodným kameňom	- Vyčistiť resp. vymeniť tvarovač prúdu
Armatúra "chodí" ťažko	- Kartuša je poškodená, vápenaté usadeniny	- Vymeniť kartušu
Batéria neustále kvapká pri vypnutí zariadení na prípravu vody	- Kartuša je poškodená	- Vymeniť kartušu



## Montáž viď strana 31



## 安全技巧

- △ 装配时为避免挤压和切割受伤，必须戴上手套。
- △ 对于5升的热水器，龙头处的流速不得超过5升/分钟。这种情况下，必须在隔离阀降低流速。

## 安装提示

- 必须按照现行的规定安装，冲洗和测试产品！
- 视需要，根据表格缩短塑料软管，并将软管上至轴环插入较短的带有蓝色标记的铜管。

## 技术参数

工作压强:	最大 1 MPa
推荐工作压强:	0,1 - 0,5 MPa
测试压强:	1,6 MPa
(1 MPa = 10 bar = 147 PSI)	
热水温度:	最大 80° C
推荐热水温度:	65° C
流速:	最大 5 升/分钟

## 符号说明

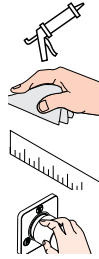

请勿使用含有乙酸的硅！

**清洗**  
附有小手册  
**大小** (参见第 33 页)

**操作** (参见第 34 页)  
加热贮水箱时，水嘴滴水。



**检验标记** (参见第 34 页)

**备用零件** (参见第 35 页)  
更换喷雾形成器时，必须使用针对此类龙头制造的形成器。

## 选装附件



专用工具 (58085000) 不在供货范围内

水管胶泥 不在供货范围内

## 需要使用的节流软管长度表

使用点上最高可能的水压，单位：Mpa	仪器容量	
	8、10和15升	5升以下
0,1 0,15	无节流软管	节流软管缩短到90mm
0,2 0,3	节流软管缩短到90mm	节流软管不变
0,4 0,7	节流软管不变 调整角阀上的流量	

如果水压大于0,5 MPa，安装减压阀。

问题	原因	补救
龙头出水量小	- 花洒结垢，脏污	- 清洁花洒，视需要更换
龙头不灵活	- 滤筒损坏，结垢	- 更换滤筒
热水器关闭后，龙头持续滴水	- 滤筒损坏	- 更换滤筒



**安装 参见第 31 页**



## Указания по технике безопасности

- Во время монтажа следует надеть перчатки во избежание прищемления и порезов.
- Для 5-литровых приборов производительность выхода на смесителе не должна превышать 5 л/мин. При необходимости отрегулируйте подачу воды на угловом вентиле

## Указания по монтажу

- Смеситель должен быть смонтирован по действующим нормам и в соответствии с настоящей инструкцией, проверен на герметичность и безупречность работы
- Пластмассовый шланг, если необходимо, укоротите, согласно таблице и вставьте в короткую трубу с синей маркировкой до буртика.

## Технические данные

Рабочее давление: не более. 1 МПа  
 Рекомендуемое рабочее давление: 0,1 - 0,5 МПа  
 Давления: 1,6 МПа  
 (1 МПа = 10 bar = 147 PSI)  
 Температура горячей воды: не более. 80 °С  
 Рекомендуемая темп. гор. воды: 65 °С  
 Пропускная способность: не более. 5 л/мин

## Описание символов



Не применяйте силикон, содержащий уксусную кислоту.



**Очистка**  
см прилагаемая брошюра



**Размеры** (см. стр. 33)



**Эксплуатация** (см. стр. 34)

При подогреве водяного резервуара из выхода капает вода.



**Знак технического контроля**  
(см. стр. 34)



**Комплект** (см. стр. 35)

При замене формирователя струи необходимо использовать формирователь струи, предназначенный для этой арматуры.

## Специальные принадлежности



Монтажный ключ (58085000) не включено в объем поставки!



Монтаж подводки не включено в объем поставки!

**Таблица длин используемых шлангов дросселя**

Максимальное давление воды на участке применения в МПа	Емкость устройств	
	8, 10 и 15 литров	до 5 литров
0,1 - 0,15	Без шланга дросселя	Шланг дросселя укороченный, длина 90 мм
0,2 - 0,3	Шланг дросселя укороченный, длина 90 мм	Шланг дросселя неизменной длины
0,4 - 0,7	Шланг дросселя неизменной длины отрегулируйте расход воды на угловом клапане	

При статическом давлении более 0,5 МПа необходимо устанавливать редукционный клапан.

## Неисправность

## Причина

## Устранение неисправности

недостаточный давление (если устан напор воды)

- Формирователь струи имеет известковые отложения/загрязнен

- Очистите формирователь струи, по мере необходимости замените

Арматура работает с усилием

- Картридж неисправен, засорение накипью

- Замените картридж

Из арматуры при подключенном водонагревателе постоянно капает вода



- Картридж неисправен

- Замените картридж





## Biztonsági utasítások

-  A szerelésnél a zúzódások és vágási sérülések elkerülése érdekében kesztyűt kell viselni.
-  Az 5 literes készülékeknél a keverő kifolyóteljesítménye nem haladhatja meg az 5 l/perc értéket. Adott esetben szabályozzuk a sarokszelepnél a vízbefolyást.

## Szerelési utasítások

- A csaptelepet az érvényben lévő előírásoknak megfelelően kell felszerelni, átöblíteni és ellenőrizni!
- Amennyiben szükséges, a táblázat szerint rövidítsük meg a műanyagtömlőt, és karimáig dugjuk be a rövid, késsel jelzett csőbe.

## Műszaki adatok

Üzemi nyomás:	max. 1 MPa
Ajánlott üzemi nyomás:	0,1 - 0,5 MPa
Nyomáspróba:	1,6 MPa
(1 MPa = 10 bar = 147 PSI)	
Forróvíz hőmérséklet:	max. 80 °C
Forróvíz javasolt hőmérséklete:	65 °C
Átfolyási teljesítmény :	max. 5 l/perc

## Szimbólumok leírása



Ne használjon ecetsavtartalmú szilikon!



### Tisztítás

lásd a mellékelt brosúrát.



### Méretet (lásd a 33. oldalon)



### Használat (lásd a 34. oldalon)

A víztároló felfűtésekora a kifolyónál vízcsap-egés lép fel.



### Vizsgajel (lásd a 34. oldalon)



### Tartozékok (lásd a 35. oldalon)

Ha kicseréli a sugárformázót, akkor ehhez a csaptelephez jóváhagyott sugárformázót kell használni.

### Egyéb tartozék

Szerelőkulcs (58085000) a szállítási egység nem tartalmazza



szaniter szilikon a szállítási egység nem tartalmazza



## Táblázat a használt szűkítő hosszúságokról

Legnagyobb lehetséges víznyomás a használati helyen MPa-ban	Készülék űrtartalma	
	8, 10 és 15 liter	5 literig
0,1 - 0,15	szűkítő nélkül	szűkítő 90 mm-re rövidítve
0,2 - 0,3	szűkítő 90 mm-re rövidítve	szűkítő változatlan
0,4 - 0,7	szűkítő változatlan a befolyási mennyiséget a sarokszelepnél lehet szabályozni	

0,5 MPa feletti alapnyomásnál nyomáscsökkentőt kell beszerelni.

Hiba	Ok	Megoldás
Kevés víz	- Sugárformázó elvízkövesedett, elszennyeződött	- Sugárformázó tisztítása, adott esetben cseréje
Nehezen nyitható a csap.	- A kerámiabetét meghibásodott, elvízkövesedett.	- A kerámiabetétet ki kell cserélni.
A csaptelep kikapcsolt vízkészítőnél állandóan csepeg	- A kerámiabetét meghibásodott.	- A kerámiabetétet ki kell cserélni.



**Szerelés lásd a 31. oldalon**





## Turvallisuusohjeet

- Asennuksessa on käytettävä käsineitä puristumien ja viiltojen aiheuttamien tapaturmien estämiseksi.
- Viiden litran laitteilla sekoittajasta ulos tulevan veden määrä ei saa ylittää 5 litraa minuutissa. Rajoita tarvittaessa veden tuloa kulmaventtiilillä.

## Asennusohjeet

- Kaluste on asennettava, huuhdeltava ja tarkastettava voimassa olevien määräysten mukaisesti!
- Lyhennä muoviletua, jos tarpeen, taulukon mukaan ja työnnä se lyhyen, sinisellä merkityn putken sisään laippaan asti.

## Tekniset tiedot

Käyttöpaine:	maks. 1 MPa
Suosittelut käyttöpaine:	0,1 - 0,5 MPa
Koestuspaine:	1,6 MPa
(1 MPa = 10 bar = 147 PSI)	
Kuuman veden lämpötila:	maks. 80 °C
Kuuman veden suosituslämpötila:	65 °C
Läpivirtausmäärä:	maks. 5 l/min

## Merkin kuvaus



Älä käytä etikkahappopitoista silikonial



### Puhdistus

katso oheinen esite



### Mitat (katso sivu 33)



### Käyttö (katso sivu 34)

Vedenvaraajaa kuumennettaessa juoksuput-  
kesta tippuu vettä.



### Koestusmerkki (katso sivu 34)



### Varaosat (katso sivu 35)

Jos vesisuikun muotoilija vaihdetaan, on  
käytettävä tälle kalusteelle hyväksyttyä  
muotoilijaa.



### Erityisvaruste

Asennusavain (58085000) ei kuulu toimi-  
tukseen



Asennussarja ei kuulu toimitukseen

## Taulukko käytettävistä kuristinletkujen pituuksista

Suurin mahdollinen vedenpaine käyttöpaikassa (Mpa)	Laitteen sisältö	
	8, 10 ja 15 litraa	5 litraan asti
0,1 - 0,15	ilman kuristinletkua	Kuristinletku lyhennetty 90 mm:iin
0,2 - 0,3	Kuristinletku lyhennetty 90 mm:iin	Kuristinletku ilman muutoksia
0,4 - 0,7	Kuristinletku ilman muutoksia Läpivirtausmäärä säädetään kulmaventtiilistä	

On käytettävä paineenalenninta, jos lepopaine on yli 0,5 MPa.

## Häiriö

Vähän vettä

## Syy

- Suihkunmuotoilija kalkkiintunut,  
likaantunut

## Toimenpide

- Puhdista suihkunmuotoilija, vaihda  
tarvittaessa

Hana on raskaskäyttöinen

- Patruuna rikki, kalkkikerrostumia

- Vaihda patruuna

Hanasta tippuu jatkuvasti vettä ve-  
denkäsittelylaitteen ollessa kytkettynä  
pois päältä

- Patruuna rikki

- Vaihda patruuna



## Asennus katso sivu 31



## ! Säkerhetsanvisningar

- △ Handskar ska bäras under monteringsarbetet så att man kan undvika kläm- och skärskadorgen werden.
- △ Utflödeseffekten i blandaren får inte överstiga 5l/ minut hos 5 liters behållare. Ställ in vattenflödet vid hörnventilen om detta behövs.

## Monteringsanvisningar

- Blandaren måste installeras, genomspolas och testas enligt gällande föreskrifter.
- Korta plastslangen enligt tabell, om detta behövs, och skjut in den i det korta, blåmarkerade röret till kragen.

## Tekniska data

Driftstryck:	max. 1 MPa
Rek. driftstryck:	0,1 - 0,5 MPa
Tryck vid provtryckning: (1 MPa = 10 bar = 147 PSI)	1,6 MPa
Varmvattentemperatur:	max. 80 °C
Rek. varmvattentemp.:	65 °C
Genomströmningmängd:	max. 5 l/min

## Simbolio aprašymas

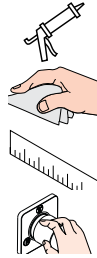

Använd inte silikon som innehåller ättiksyra!

### Rengöring

se den medföljande broschyren

### Måtten (se sidan 33)

### Hantering (se sidan 34)

Vatten droppar från den utdragbara blandaren när vattenberedaren värms upp.

### Testsigill (se sidan 34)



### Reservdelar (se sidan 35)

Om strålkanselenheten byts måste en enhet som passar till blandaren användas.

### Specialtillbehör



Monteringsnyckel (58085000) medföljer ej leveransen

Installationskit medföljer ej leveransen

## Tabell över de reduceringslang-längder som ska användas

Högsta möjliga vattentryck på användningsplatsen i MPa	Apparatinnehåll	
	8, 10 och 15 liter	till 5 liter
0,1 - 0,15	utan reduceringslang	Reduceringslang kortad till 90 mm
0,2 - 0,3	Reduceringslang kortad till 90 mm	Reduceringslang oförändrad
0,4 - 0,7	Reduceringslang oförändrad Ställ in flödesmängden på hörnventilen	

Vid vilotryck på mer än 0,5 MPa måste en tryckregulator monteras.

## Störning

## Orsak

## Åtgärd

För lite vatten

- Strålkkanaler är täckta av kalk, smutsiga

- Rengör strålkkanaler, byt ut enhet om nödvändigt

Blandare är trög

- Patron defekt, förkalkad

- Byt ut patron

Blandaren droppar ständigt när vattnet är avstängt

- Patron defekt

- Byt ut patron





## Saugumo technikos nurodymai

- ⚠ Apsaugai nuo užspaudimo ir įsijopavimo montavimo metu mūvėkite pirštines.
- ⚠ Jei vandens šildytuvų talpa 5 litrai, maišytuvo vandens tekėjimo norma neturėtų viršyti 5 l/mažiausiai. Jei norma viršijama, reikia sumažinti kampinių vožtuvų srauto pralaidumą.

## Montavimo instrukcija

- Maišytuvą privalo būti montuojamas, išleidžiamas ir patikrinamas pagal galiojančias normas!
- Jei reikia, pagal lentelę sutrumpinkite plastikinę žarną ir įdėkite ją į trumpą, mėlynai pažymėtą vamzdelį.

## Techniniai duomenys

Darbinis slėgis: ne daugiau kaip 1 MPa  
 Rekomenduojamas slėgis: 0,1 - 0,5 MPa  
 Bandomasis slėgis: 1,6 MPa  
 (1 MPa = 10 barų = 147 PSI)  
 Karšto vandens temperatūra: ne daugiau kaip 80 °C  
 Rekomenduojama karšto vandens temperatūra: 65 °C  
 Vandens pralaidumas: ne daugiau kaip 5 l/min

## Simbolio aprašymas



Nenaudokite silikono, kurio sudėtyje yra acto rūgšties!



**Valymas**  
 žr. pridedamoje brošiūroje.



**Išmatavimai** (žr. psl. 33)



**Eksplotacija** (žr. psl. 34)  
 Kaitinant vandens talpą čiaupas lašės.



**Bandymo pažyma** (žr. psl. 34)



**Atsarginės dalys** (žr. psl. 35)  
 Keičiant čiaupą būtina naudokite šitam maišytuvui pritaikytą čiaupą.



## Specialūs priedai

Montavimo raktas (58085000) nėra pridedama



Montavimo rinkinys nėra pridedama

## Naudotinių droselių žarnų ilgių lentelė

Didžiausias galimas vandens slėgis naudojimo vietoje, MPa	Prietaiso sudėtis	
	8, 10 ir 15 litrų	iki 5 litrų
0,1 - 0,15	Be droselio žarnos	Droselio žarna sutrumpinta 90 mm
0,2 - 0,3	Droselio žarna sutrumpinta 90 mm	Droselio žarna nekeičiama
0,4 - 0,7	Droselio žarna nekeičiama reguliuojamas kampinio vožtuvo vandens sunaudojimas	

Jei vandens slėgis yra didesnis nei 0,5 MPa, privalo būti įmontuotas slėgio ribotuvas.

## Gedimas

## Priežastis

## Priemonė

Per maža srovė

- Čiaupas užkalkėjęs arba jame yra šiukšlį

- Čiaupą išvalyti arba pakeisti

Sunkiai sukiojama rankenėlė

- Kasetė pažeista, užkalkėjusi

- Pakeisti kasetę

Uždarius, maišytuvą nuolat pralaidžia vandenį



- Kasetė pažeista

- Pakeisti kasetę





## Sigurnosne upute

-  Prilikom montaže se radi sprječavanja prignječenja i posjekotina moraju nositi rukavice.
-  Kod 5 -litarskih uređaja protok u mješalici ne smije prijeći 5 litara/min. Regulirajte dotok vode na kutnom ventilu

## Upute za montažu

- Cijevi moraju biti postavljene, isprane i testirane prema važećim normama!
- Ukoliko je potrebno skratite plastično crijevo prema tabeli i gurnite ga do kraja u kratku, plavo označenu cijev

## Tehnički podatci

Najveći dopušteni tlak:	tlak 1 MPa
Preporučeni tlak:	0,1 - 0,5 MPa
Probni tlak:	1,6 MPa
(1 MPa = 10 bar = 147 PSI)	
Temperatura vruće vode:	tlak 80 °C
Preporučena temperatura vruće vode:	65 °C
Protok vode:	tlak 5 l/min

## Opis simbola



Nemojte koristiti silikon koji sadrži octenu kiselinu!



### Čišćenje

se u priloženoj brošuri.



### Mjere (pogledaj stranicu 33)



### Upotreba (pogledaj stranicu 34)

Pri zagrijavanju bojlera na izlazu slavine pojavit će se kapljice vode



### Oznaka testiranja (pogledaj stranicu 34)



### Rezervni djelovi (pogledaj stranicu 35)

Ako želite izmijeniti mjenjač mlaza, potrebno je koristiti mjenjač propisan uz ovu armaturu

### Posebni pribor



ključ za montažu (58085000) Nije sadržano u isporuci!



Instalaterski kit Nije sadržano u isporuci!

## Tablica mogućih duljina plastičnih crijeva

Najveći mogući tlak na mjestu primjene u MPa	Kapacitet uređaja	
	8, 10 i 15 litara	do 5 litara
0,1 - 0,15	bez plastičnog crijeva	plastično crijevo skraćeno na 90 mm
0,2 - 0,3	plastično crijevo skraćeno na 90 mm	plastično crijevo bez izmjene
0,4 - 0,7	plastično crijevo bez izmjene namjestite protočnu količinu na kutnom ventilu	

Kod tlaka većeg od 0,5 MPa mora biti ugrađen uređaj za smanjivanje tlaka

Greška	Uzrok	Otklanjanje
Nedovoljno vode	- Mjenjač mlaza je prljan ili začepljen naslagama kamenca	- Očistite ili zamijenite mjenjač mlaza
Ručica se zaglavila	- Neispravan uložak Taloženje kamenca	- Zamijenite uložak
Slavina kaplje i kad je grijavač vode zatvoren	- Neispravan uložak	- Zamijenite uložak



## Sastavljanje pogledaj stranicu 31



## ⚠ Güvenlik uyarıları

- ⚠ Montaj esnasında ezilme ve kesilme gibi yaralanmaları önlemek için eldiven kullanılmalıdır.
- ⚠ 5 litrelik cihazlarda, mks bataryadaki çıkış gücü 5 l/dk'yı aşmamalıdır. Gerekirse, ara musluktaki su beslemesini ayarlayın.

## Montaj açıklamaları

- Batarya geçerli normlara göre monte edilmeli, yıkanmalı ve kontrol edilmelidir!
- Gerekirse, plastik hortumu tabloya göre kısaltın ve kısa, mavi işaretli borudaki faturaya kadar içeri itin.

## Teknik bilgiler

İşletme basıncı:	azami 1 MPa
Tavsiye edilen işletme basıncı:	0,1 - 0,5 MPa
Kontrol basıncı:	1,6 MPa
(1 MPa = 10 bar = 147 PSI)	
Sıcak su sıcaklığı:	azami 80 °C
Tavsiye edilen su ısısı:	65 °C
Debisi :	azami 5 l/dak

## Simge açıklaması



Asetik asit içeren silikon kullanmayın!



**Temizleme**  
birlikte verilen broşür



**Ölçüleri** (Bakınız sayfa 33)



**Kullanımı** (Bakınız sayfa 34)

Su deposunun ısınması durumunda, çıkıştan su damlaları akar.



**Kontrol işareti** (Bakınız sayfa 34)



**Yedek Parçalar** (Bakınız sayfa 35)

Sprey modül değiştirilirse, bu batarya için izin verilmiş bir sprej modül kullanılmalıdır.



**Özel aksesuarlar**

Montaj anahtarı (58085000) Teslimat kapsamına dahil değildir



Montaj silikonu Teslimat kapsamına dahil değildir

## Kullanılacak regülatörlü hortum uzunlukları ile ilgili tablo

Kullanılan yerdeki maksimum su basıncı (Mpa)	Cihaz içeriği	
	8, 10 ve 15 litre	5 litreye kadar
0,1 - 0,15	Regülatörlü hortum kullanılmadan	Regülatörlü hortum 90 mm'ye kısaltılarak
0,2 - 0,3	Regülatörlü hortum 90 mm'ye kısaltılarak	Regülatörlü hortum değiştirilmeden
0,4 - 0,7	Regülatörlü hortum değiştirilmeden Köşe valftaki akış miktarını ayarlama	

0,5 MPa üzerindeki durağan basınçta bir basınç azaltıcı takılmalıdır.



arıza	sebebe	yardım
Az su geliyor	- Sprey modül kireçlenmiş, kirlenmiş	- Sprey modülü temizleyin, gerekirse değiştirin
Batarya kullanımı ağırlaşıyor	- Kartuş Bozulmuş ve kireçlenmiş olabilir	- Kartuşu değiştirin
Su hazırlayıcı kapalıyken batarya sürekli olarak su damlatıyor	- Kartuş bozuk olabilir	- Kartuşu değiştirin



**Montajı Bakınız sayfa 31**



## Instrucțiuni de siguranță

-  La montare utilizați mănuși pentru evitarea contuziunilor și tăierii mâinilor.
-  La boilere de apă de 5 litri debitul apei la amestecător nu trebuie să depășească 5 l/min. În caz contrar reglați debitul de apă cu ajutorul ventilelor de colț.

## Instrucțiuni de montare

- Bateria trebuie montată, clătită și verificată conform normelor în vigoare.
- Scurtați furtunul de plastic dacă este necesar conform tabelului și împingeți furtunul marcat cu albastru până la cuplaj.

## Date tehnice

Presiune de funcționare:	max. 1 MPa
Presiune de funcționare recomandată:	0,1 - 0,5 MPa
Presiune de verificare: (1 MPa = 10 bar = 147 PSI)	1,6 MPa
Temperatura apei calde:	max. 80 °C
Temperatura recomandată a apei calde:	65 °C
Debit de apă:	max. 5 l/min

## Descrierea simbolurilor

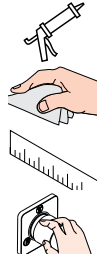

Nu utilizați silicon cu conținut de acid acetic!

### Curățare

vezi broșura alăturată.

### Dimensiuni (vezi pag. 33)

### Utilizare (vezi pag. 34)

La încălzirea rezervorului de apă, apa picură din pipă.



### Certificat de testare

(vezi pag. 34)



### Piese de schimb (vezi pag. 35)

Dacă schimbați duza de jet, trebuie să utilizați o duză jet potrivită pentru această baterie.

### Accesorii opționale

Cheie pentru montare (58085000) nu este inclus în setul livrat



Chit de instalare nu este inclus în setul livrat



## Tabelă cu lungimile de furtun de reducere utilizate

Presiunea de apă cea mai ridicată la locul de utilizare în MPa	Conținutul aparatului	
	8, 10 și 15 litri	până la 5 litri
0,1 - 0,15	fără furtun de reducere	Furtun de reducere prescurtat la 90 mm
0,2 - 0,3	Furtun de reducere prescurtat la 90 mm	Furtun de reducere neschimbat
0,4 - 0,7	Furtun de reducere neschimbat Reglarea debitului la robinetul cu ventil de colț	

La o presiune de repaus de peste 0,5 MPa trebuie montată un reductor de presiune.

## Deranjament

## Cauza

## Măsuri de remediere

Prea puțină apă

- Depuneri de calcar și impurități pe duza jet.

- Curățați sau schimbați duza jet dacă este cazul.

Bateria se mișcă dificil

- Cartuș defect din cauza depunerilor de calcar

- Schimbați cartușul.

Picură în continuu din baterie când boilerul de apă este oprit.

- Cartuș defect

- Schimbați cartușul.



## Montare vezi pag. 31



## ⚠ Υποδείξεις ασφαλείας

- ⚠ Για να αποφύγετε τραυματισμούς κατά τη συναρμολόγηση πρέπει να φοράτε γάντια.
- ⚠ Σε συσκευές 5 λίτρων, η κατανάλωση νερού της μπαταρίας (μείκτη) δεν επιτρέπεται να υπερβαίνει τα 5 λίτρα ανά λεπτό. Αν χρειαστεί, ρυθμίστε την παροχή νερού στη γωνιακή βαλβίδα.

## Οδηγίες συναρμολόγησης

- Η κεντρική βάνα πρέπει να τοποθετηθεί, να πλυθεί και να ελεγχθεί με βάση τους ισχύοντες κανόνες υδραυλικής τέχνης!
- Εάν χρειαστεί, κόψτε το σωλήνα από καουτσούκ, σύμφωνα με τον πίνακα, και τοποθετήστε τον μέχρι το περιλαίμιο στον κοντό σωλήνα που φέρει μπλε σήμανση.

## Τεχνικά Χαρακτηριστικά

Λειτουργία πίεσης:	έως 1 MPa
Συνιστώμενη λειτουργία πίεσης:	0,1 - 0,5 MPa
Πίεση ελέγχου:	1,6 MPa
(1 MPa = 10 bar = 147 PSI)	
Θερμοκρασία ζεστού νερού:	έως 80 °C
Συνιστώμενη θερμοκρασία ζεστού νερού:	65 °C
Κατανάλωση νερού:	έως 5 l/min

## Περιγραφή συμβόλων



Μην χρησιμοποιείτε σιλικόνη που περιέχει οξικό οξύ!



### Καθαρισμός

βλ. συνημμένο φυλλάδιο



### Διαστάσεις (βλ. σελίδα 33)



### Χειρισμός (βλ. σελίδα 34)

Σε περίπτωση θέρμανσης της δεξαμενής νερού, στο στόμιο εκροής εμφανίζονται σταγονίδια νερού.



### Σήμα ελέγχου (βλ. σελίδα 34)



### Ανταλλακτικά ( βλ. σελίδα 35 )

Εάν γίνει αλλαγή των καναλιών καταιονισμού, πρέπει να χρησιμοποιηθεί ένας επιτρεπόμενος για τη συγκεκριμένη βάνα καταιονιστήρας.

### Ειδικά αξεσουάρ



Κλειδί συναρμολόγησης (58085000) δεν περιλαμβάνεται στον παραδοτέο εξοπλισμό



Κιτ εγκατάστασης δεν περιλαμβάνεται στον παραδοτέο εξοπλισμό

## Πίνακας αντιστοιχων μηκών σωλήνα μείωσης

Μέγιστη δυνατή πίεση νερού στο σημείο χρήσης σε MPa	Περιεχόμενο συσκευής	
	8, 10 και 15 λίτρα χωρίς σωλήνα μείωσης	έως 5 λίτρα Σωλήνας μείωσης κοντυμένος στα 90 mm
0,1 - 0,15	χωρίς σωλήνα μείωσης	Σωλήνας μείωσης κοντυμένος στα 90 mm
0,2 - 0,3	Σωλήνας μείωσης κοντυμένος στα 90 mm	Σωλήνας μείωσης χωρίς αλλαγή
0,4 - 0,7	Σωλήνας μείωσης χωρίς αλλαγή Ρυθμίστε την ποσότητα ροής στη γωνιακή βαλβίδα	



Σε περίπτωση πίεσης ηρεμίας άνω των 0,5 MPa, θα πρέπει να εγκατασταθεί ένας μειωτής πίεσης.

Βλάβη	Αιτία	Διόρθωση
Ανεπαρκές νερό	- Ο καταιονιστήρας (ντους) φέρει άλατα και βρωμιές	- Καθαρίστε και, εάν χρειαστεί, αλλάξτε τον καταιονιστήρα (ντους)
Σκληρή μπαταρία (μείκτης)	- Ελαττωματικό φυσιγγίο, άλατα	- Αλλαγή φυσιγγίου
Η μπαταρία στάζει διαρκώς σε απεργοποιημένο θερμοσίφωνα	- Ελαττωματικό φυσιγγίο	- Αλλαγή φυσιγγίου





## Varnostna opozorila

-  Pri montaži je treba nositi rokavice, da se prepreči poškodbe zaradi zmečkanja ali urezov.
-  Pri 5-litrskih aparatih zmogljivost izliva na mešalni bateriji ne sme presežati 5 l/min. Če je potrebno, se na kotnem ventilu nastavi dotok vode.

## Navodila za montažo

- La robinetterie doit être installée, rincée et contrôlée conformément aux normes valables!
- Skrajšajte plastično cev v skladu s tabelo, če je to potrebno, in potisnite kratko, modro označeno cev do obročka.

## Tehnični podatki

Delovni tlak:	maks. 1 MPa
Priporočeni delovni tlak:	0,1 - 0,5 MPa
Preskusni tlak:	1,6 MPa
(1 MPa = 10 bar = 147 PSI)	
Temperatura tople vode:	maks. 80 °C
Priporočena temperatura tople vode:	65 °C
Pretok vode:	maks. 5 l/min

## Opis simbola



Ne smete uporabiti silikona, ki vsebuje očetno kislino!



**Čiščenje**  
glejte priloženi brošuri.



**Mere** (glejte stran 33)



**Upravljanje** (glejte stran 34)

Pri segrevanju rezervoarja za vodo na izlivu kaplja.



**Preskusni znak** (glejte stran 34)



**Rezervni deli** (glejte stran 35)

Če zamenjate oblikovalnik curkov, morate uporabiti takega, ki je primeren za ta tip armature.

## Poseben pribor

Montažni ključ (58085000) Ni vključeno



Komplet za montažo Ni vključeno



## Tabela za dolžine dušilne cevi, ki jih je treba uporabiti

Najvišji možen vodni tlak na mestu uporabe v MPa	Vsebina priprave	
	8, 10 in 15 litrov	do 5 litrov
0,1 - 0,15	brez dušilne cevi	dušilna cev skrajšana na 90 mm
0,2 - 0,3	dušilna cev skrajšana na 90 mm	dušilna cev nespremenjena
0,4 - 0,7	dušilna cev nespremenjena reguliranje količine pretoka na kotnem ventilu	

Kui vee surve on üle 0,5 MPa, tuleb paigaldada survealandusventil.

Napaka	Vzrok	Pomoč
Malo vode	- Oblikovalnik curka je poapnen, umazan	- Očistite oz. po potrebi zamenjajte oblikovalnik curka
Težko premikanje armature	- Pokvarjen vložek, poapneno	- Zamenjajte vložek
Iz armature stalno kaplja ob izklopljenem grelniku	- Pokvarjen vložek	- Zamenjajte vložek



**Montaža Glejte stran 31.**





## ⚠ Ohutusjuhised

- ⚠ Kandke paigaldamisel muljumis- ja löikevigastuste vältimiseks kindaid.
- ⚠ 5-liitriste veeboilerite puhul ei või segisti väljavool ületada 5 l/min. Vajadusel piirake nurgaklapist vee juurdevoolu.

## Paigaldamisjuhised

- Segisti paigaldamine, loputamine ja kontroll peab toimuma vastavalt kehtivatele normidele!
- Vajaduse korral lõigake plastvoolik vastavalt tabelile lühemaks ning lükake see kuni kaeluseni sinisega markeeritud vasktorusse.

## Tehnilised andmed

Töörõhk	maks. 1 MPa
Soovitatav töörõhk:	0,1 - 0,5 MPa
Kontrollsurve:	1,6 MPa
(1 MPa = 10 baari = 147 PSI)	
Kuuma vee temperatuur:	maks. 80 °C
Soovitatav kuuma vee temperatuur:	65 °C
Läbivool:	maks. 5 l/min

## Sümbolite kirjeldus



Ärge kasutage äädikhapet sisaldavat silikooni!



**Puhastamine**  
vt kaasasolevast brošüürist.



**Mõõtude** (vt lk 33)



**Kasutamine** (vt lk 34)  
Veemahuti kuumutamisel hakkab väljavool tilkuma.



**Kontrollsertifikaat** (vt lk 34)



**Varuosad** (vt lk 35)  
Joavormija vahetamise korral tuleb kasutada vaid selle segisti jaoks lubatud vormijat.

## Spetsiaalne lisavarustus

Montaaživõti (58085000) ei sisaldu komplektis

Paigalduskomplekt ei sisaldu komplektis



## Vajalike voolikupikkuste tabel

Maksimaalne võimalik veesurve kasutuskoahas (MPa)	Seadme sisu	
	8, 10 ja 15 liitrit	kuni 5 liitrit
0,1 - 0,15	voolikuta	Voolik lühendatud 90 mm peale
0,2 - 0,3	Voolik lühendatud 90 mm peale	Muutmata voolik
0,4 - 0,7	Muutmata voolik reguleerige läbivoolukogust nurkventiilist	

Če tlak v mirovanju presega 0,5 MPa, je potrebno vgraditi napravo za zniževanje tlaka.

Rike	Põhjus	Lahendus
Vähe vett	- Veepihusti lubjastunud, must	- Puhastage veepihusti, vajadusel vahetage välja
Segisti käib raskelt	- Tööelement on katkine, lubjastunud	- Vahetage tööelement
Segisti tilgub pidevalt, kui veeboiler on välja lülitatud	- Tööelement on katkine	- Vahetage tööelement



## Paigaldamine vt lk 31



## Drošības norādes

- Montāžas laikā, lai izvairītos no spiedumiem un iegriezumiem, nepieciešams nēsāt cimdus.
- 5 l ūdens sildītājiem caurplūde jāucējkrānam nedrīkst pārsniegt 5 l/min. Nepieciešamības gadījumā ūdens padevi regulē ar stūra ventili.

## Norādījumi montāžai

- Armatūra jāuzstāda, jāizskalo un jāpārbauda atbilstoši spēkā esošajām normām!
- Ja nepieciešams, plastmasas šļūteni atbilstoši tabulai saīsina un iebāž īsajā, ar zilu krāsu marķētajā caurulē līdz savienojumam.

## Tehniskie dati

Darba spiediens:	maks. 1 MPa
leteicamais darba spiediens:	0,1 - 0,5 MPa
Pārbaudes spiediens: (1 MPa = 10 bar = 147 PSI)	1,6 MPa
Karstā ūdens temperatūra:	maks. 80 °C
leteicamā karstā ūdens temperatūra:	65 °C
Caurteces intensitāte:	maks. 5 l/min

## Simbolu nozīme



Neizmantojot silikonu, kas satur etiķskābi!



**Tirīšana**  
skatiet pievienotajā brošūrā.



**Izmērus** (skat. 33. lpp.)



**Lietošana** (skat. 34. lpp.)  
Karsējot ūdens boileri pa snipi pil ūdens.



**Pārbaudes zīme** (skat. 34. lpp.)



**Rezerves daļas** (skat. 35. lpp.)  
Ja tiek nomainīts strūkļas veidotājs, jāizmanto šim jāucējkrānam paredzēts strūkļas veidotājs.



## Speciāli aksesuāri

Montāžas atslēga (58085000) komplektā netiek piegādāts



Instalācijas piederumi komplektā netiek piegādāts

## Tabula par izmantojamo plastmasas šļūtenu garumu

Maksimālais iespējamais ūdens spiediens ņemšanas vietā MPa	Lerīču tilpums	
0,1 - 0,15	8, 10 un 15 litri bez plastmasas šļūtenes	līdz 5 litriem Plastmasas šļūtene saīsina līdz 90 mm
0,2 - 0,3	Plastmasas šļūtene saīsina līdz 90 mm	Plastmasas šļūtene bez izmaiņām
0,4 - 0,7	Plastmasas šļūtene bez izmaiņām caurplūdes daudzumu regulējiet ar leņķvārstu	

Ja ūdens spiediens ir lielāks par 0,5 MPa, jāiebūvē spiediena reduktors.

## Traucējums

Maz ūdens

## Iemesls

- Strūkļas veidotājs ir aizkaļķojies, nefīrs

## Bojājumu novēršana

- Izfīrīt, nepieciešamības gad. nomainīt strūkļas veidotāju

Jāucējkrāns smagi grozāms

- Bojāta kartuša, aizkaļķojusies

- Nomainīt kartušu

Jāucējkrāns nepārtraukti pil arī izslēgta ūdens sagatavotāja gadījumā

- Bojāta kartuša

- Nomainīt kartušu



## Montāža skat. 31. lpp.



## Sigurnosne napomene

- Prilikom montaže se radi sprečavanja prignječenja i posekofina moraju nositi rukavice.
- Kod 5 -litarskih uređaja protok u mešaču ne sme preći 5 l/min. Regulirajte dotok vode na ugaonom ventilu.

## Instrukcije za montažu

- Armatura mora biti postavljena, isprana i testirana prema važećim normama!
- Ukoliko je potrebno skratite plastično crevo prema tabeli i gurnite ga do kraja u kratku, plavo označenu cev.

## Tehnički podaci

Radni pritisak:	maks. 1 MPa
Preporučeni radni pritisak:	0,1 - 0,5 MPa
Probni pritisak:	1,6 MPa
(1 MPa = 10 bar = 147 PSI)	
Temperatura vruće vode:	maks. 80 °C
Preporučena temperatura vruće vode:	65 °C
Protok vode:	maks. 5 l/min

## Opis simbola



Nemojte koristiti silikon koji sadrži sirćetnu kiselinu!



### Čišćenje

vidi priloženoj brošuri.



**Mere** (vidi stranu 33)



**Rukovanje** (vidi stranu 34)

Kada se bojler zagreva, slavina počinje da kaplje.



**Ispitni znak** (vidi stranu 34)



**Rezervni delovi** (vidi stranu 35)

Ako želite zameniti uobličavač mlaza, sme se koristiti samo uobličavač dozvoljen za ovu armaturu.

## Poseban pribor



ključ za montažu (58085000) Nije sadržano u isporuci



Instalaterski komplet Nije sadržano u isporuci

## Tabela mogućih dužina plastičnih creva

Najveći mogući pritisak na mestu primene u MPa	Zapremina uređaja	
	8, 10 i 15 litara	do 5 litara
0,1 - 0,15	bez plastičnog creva	plastično crevo skraćeno na 90 mm
0,2 - 0,3	plastično crevo skraćeno na 90 mm	plastično crevo bez promene
0,4 - 0,7	plastično crevo bez promene protočnu količinu treba podesiti na ugaonom ventilu	

Ako je pritisak mirovanja veći od 0,5 MPa, mora se ugraditi uređaj za smanjivanje pritiska.



Smetnja	Uzrok	Pomoć
Nedovoljno vode	- Uobličavač mlaza je prljav ili začepljen naslagama kamenca	- Očistite ili zamenite uobličavač mlaza
Ručica se zaglavila	- Neispravna kartuša, nataloženi kamenac	- Zamenite kartušu
Slavina kaplje i kad je grejač vode zatvoren	- Neispravna kartuša	- Zamenite kartušu



**Montaža vidi stranu 31**



## Sikkerhetshenvisninger

-  Bruk hansker under montasjen for å unngå klem- og kuttskader.
-  Ved 5 liters apparater skal utløpsytelsen på blanded-batteriet ikke overstige 5 l/min.

## Montagehenvisninger

- Armaturen skal monteres iht. gyldige standarder. De skal spyles og sjekkes!
- Hvis nødvendig kortes plastslangen iht. tabellen og det korte blått markerte rør skyves inn til anslag.

## Tekniske data

Driftstrykk	maks. 1 MPa
Anbefalt driftstrykk:	0,1 - 0,5 MPa
Prøvetrykk	1,6 MPa
(1 MPa = 10 bar = 147 PSI)	
Varmtvannstemperatur	maks. 80°C
Anbefalt temperatur for varmt vann	65°C
Gjennomstrømningsytelse:	maks. 5 l/min

## Symbolbeskrivelse



Ikke bruk silikon som inneholder eddiksyre!



### Rengjøring

se vedlagt brosjyre.



### Mål (se side 33)



### Betjening (se side 34)

Ved oppvarming av vannbeholdningen drypper det vann fra utløpet.



### Prøvemerket (se side 34)



### Service-deler (se side 35)

Når stråleformer byttes, skal den erstattes med en stråleformer som er godkjent for denne armaturen.

### Ekstratilbehør



Montasjenøkkel (58085000) ikke med i leveransen



Installasjonskitt ikke med i leveransen

## Tabell over reduksjonsslanger som skal brukes

Størst mulig vanntrykk på bruksstedet i Mpa	Apparat innhold	
	8, 10 og 15 liter	opp til 5 liter
0,1 - 0,15	uten reduksjonsslange	Reduksjonsslange kortet ned til 90 mm
0,2 - 0,3	Reduksjonsslange kortet ned til 90 mm	Reduksjonsslange uforandret
0,4 - 0,7	Reduksjonsslange uforandret Gjennomstrømningsmengden reguleres med hjørneventil	

Ved et hviletrykk over 0,5 MPa skal det installeres en trykkreduksjon.

Feil	Årsak	Feilrettelse
Lite vann	- Stråleformer er forkalket, skitten	- Stråleformer rengjøres og byttes hvis nødvendig
Armatyr ikke lett bevegelig	- Kartusj defekt, forkalkning	- Kartusj byttes
Armatyr drypper stadig ved utkoblet vannbehandler	- Kartusj defekt	- Kartusj byttes



## Montasje se side 31



## Указания за безопасност

- ⚠ При монтажа трябва да се носят ръкавици, за да се избегнат наранявания поради притискане или порязване.
- ⚠ При 5 литрови уреди мощността на изпускане от смесителя не бива да надвишава 5 л/мин. Ако е необходимо, регулирайте подаването на вода от ъгловия клапан.

## Указания за монтаж

- Арматурата трябва да се монтира, промие и провери в съответствие с валидните норми!
- Ако е необходимо, скъсете пластмасовия маркуч съгласно таблицата и пхнете късата, маркирана със синьо тръба до фланеца.

## Технически данни

Работно налягане:	макс. 1 МПа
Препоръчително работно налягане:	0,1 - 0,5 МПа
Контролно налягане:	1,6 МПа
(1 МПа = 10 bar = 147 PSI)	
Температура на горещата вода:	макс. 80 °С
Препоръчителна температура на горещата вода:	65 °С
Мощност на потока:	макс. 5 л/мин

## Описание на символите



Не използвайте силикон, съдържащ оцветна киселина!



**Почистване**  
от приложената брошура.



**Размери** (вижте стр. 33)



**Обслужване** (вижте стр. 34)

При нагряване на резервоара за вода от изходящия накрайник капе вода.



**Контролен знак** (вижте стр. 34)



**Сервизни части** (вижте стр. 35)

Ако се сменя приспособлението за оформяне на струята, трябва да се използва приспособление, което е разрешено за тази арматура.



**Специални принадлежности**

Монтажен ключ (58085000) не се съдържа в обема на доставка



Инсталационен кит не се съдържа в обема на доставка

## Таблица на дължините на дроселиращите маркучи, които могат да се използват

Максимално възможно налягане на водата на мястото на използване в МПа	Съдържание на уреда	
	8, 10 и 15 литра	до 5 литра
0,1 - 0,15	без дроселиращ маркуч	Дроселиращ маркуч, скъсен на 90 mm
0,2 - 0,3	Дроселиращ маркуч, скъсен на 90 mm	Непроменен дроселиращ маркуч
0,4 - 0,7	Непроменен дроселиращ маркуч Регулиране на количеството на протичане на ъгловия клапан	

При статично налягане над 0,5 МПа трябва да се монтира редуктор за налягане.



Неизправност	Причина	Помощ
Малко вода	- Приспособлението за оформяне на струята е покрито с варовик, замърсен	- Почистете респ. сменете приспособлението за оформяне на струята
Трудно подвижна арматура	- Дефектна гилза, покрита с варовик	- Сменете гилзата
Арматурата капе постоянно при изключен водоподготвител	- Дефектна гилза	- Сменете гилзата



## Монтаж вижте стр. 31



## Udhëzime sigurie

-  Për të evituar lëndimet e pickimeve ose të prerjeve gjatë procesit të montimit duhet që të vishni doreza.
-  Tek pajisjet 5-litërshe kapaciteti i rrjedhjes së rubinetit me ujë të përzier nuk duhet të tejkalojë 5 l/min. Nëse është e nevojshme, atëherë rregulloni furnizimin me ujë në ventilin këndor.

## Udhëzime për montimin

- Armatura duhet montuar, shpërlarë dhe kontrolluar në bazë të normave të vlefshme!
- Zorra plastike duhet shkurtuar nëse është e nevojshme në bazë të tabelës dhe futur në tubin e shkurtër me ngjyrë të kaltër.

## Të dhëna teknike

Presioni gjatë punës	maks. 1 MPa
Presioni i rekomanduar:	0,1 - 0,5 MPa
Presioni për provë:	1,6 MPa
(1 MPa = 10 bar = 147 PSI)	
Temperatura e ujit të ngrohtë	maks. 80 °C
Temperatura e rekomanduar e ujit të ngrohtë:	65 °C
Kapaciteti i rrjedhjes:	maks. 5 l/min

## Përshkrimi i simbolit

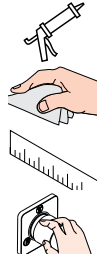

Mos përdorni silikon që në përbërje ka acid acetik.

**Pastrimi**  
shikoni broshurën bashkëngjitur.

**Përmasat** (shih faqen 33)

**Përdorimi** (shih faqen 34)

Gjatë ngrohjes së mbledhësit të ujit pikon ujë në dalje të rubinetit.



**Shenja e kontrollit**  
(shih faqen 34)

**Pjesë ndërrimi** (shih faqen 35)

Nëse ndërrohet formuesi i currilit, atëherë duhet zgjedhur një formues currili i lejuar për këtë armaturë.

## Pajisje të posaçme

Çelësi i montimit (58085000) nuk përfshihet në vëllimin e furnizimit

Stuko për instalim nuk përfshihet në vëllimin e furnizimit

## Tabela mbi gjatësitë e tubave plastikë të përdorshëm

Presioni maksimal i mundshëm i ujit në vendin e përdorimit, në Mpa (Mega Paskal)	Kapaciteti i pajisjeve	
	8, 10 dhe 15 litra	deri në 5 litra
0,1 - 0,15	pa tub plastik	Tubi plastik i shkurtuar deri në 90 mm
0,2 - 0,3	Tubi plastik i shkurtuar deri në 90 mm	Tubi plastik i pandryshuar
0,4 - 0,7	Tubi plastik i pandryshuar rregulloni sasinë e qarkullimit në valvulën këndore	

Nëse presioni edhe gjatë pushimit është mbi 0,5 MPa, atëherë duhet montuar një minimizues presioni.

## Dentim

## Shkaku

## Ndihme

Pak ujë	- Rrezatuesi me kalk, me papasterti	- Pastroni ose kembeni rrezatuesin
Armatura punon rende	- Kartusha me defekt, me kalk	- Kembeni kartushen
Armatura pikon vazhdimisht edhe kur përgatitësi i ujit është i fikur	- Kartusha me defekt	- Kembeni kartushen





### وصف الرمز

هام! لا تستخدم السليكون الذي يحتوي على أحماض!



### التنظيف

راجع والكتيب المرفق



أبعاد (راجع صفحة 33)



التشغيل (راجع صفحة 34)

عند تسخين خزان التخزين، سوف يقطر الصنبور.



شهادة اختبار (راجع صفحة 34)



قطع الغيار (راجع صفحة 35)

عند تغيير طرف الرشاش، لا بد من استخدام طرف بديل مصنوع خصيصاً لهذا النوع من الخلاطات.



### ملحقات خاصة

مفتاح التركيب (58085000) غير مدرج مع المحتويات المسلمة



طقم تركيب غير مدرج مع المحتويات المسلمة



### تنبيهات الأمان



يجب ارتداء قفازات لليد أثناء التركيب لتجنب حدوث أخطار الإنحسار أو الجروح.



عند استخدام سخانات مياه سعة 5 لتر يجب ألا يتجاوز معدل التدفق 5 ل / دقيقة. وفي هذه الحالة يجب تقليل معدل التدفق عند صمام العزل.



### تعليمات التركيب

- يجب تركيب الوصلة، وغمرها بالماء واختبارها وفقاً للمعايير السارية!
- إذا استدعى الأمر قم بتقصير الخرطوم البلاستيكي تبعاً للجدول وقم بإدخاله حتى الجلبة داخل الماسورة النحاسية الأقصر طولاً المميزة باللون الأزرق.

### المواصفات الفنية

ضغط التشغيل: الحد الأقصى 1 ميجاباسكال  
 ضغط التشغيل الموصى به: 0,5 - 0,1 ميجاباسكال  
 ضغط الاختبار: 1,6 ميجاباسكال  
 (1 ميجاباسكال = 10 بار = 147 PSI)  
 درجة حرارة الماء الساخن: الحد الأقصى 80°C  
 درجة الحرارة الموصى بها للماء الساخن: 65°C  
 معدل التدفق: الحد الأقصى 5 لتر / الدقيقة

### قائمة حول أطوال خرطوم السد التي سيتم إستخدامها

محتوى الجهاز	أعلى نسبة ضغط للماء في مجال الإستخدام بالميجا بسكال
حتى 5 لتر	مقدار 8,10 و 15 لتر
تم تقصير خرطوم السد لطول 90 مم	بدون خرطوم سد
لم يتم تغيير خرطوم السد	تم تقصير خرطوم السد لطول 90 مم
لم يتم تغيير خرطوم السد	يجب ضبط الكمية المناسبة في صمام الزاوية
	0,1 - 0,15
	0,2 - 0,3
	0,4 - 0,7

إذا تجاوز ضغط الماء 0,5 ميجاباسكال، قم بتركيب صمام خافض للضغط.

العلاج والإصلاح	السبب	المطل
- قم بتنظيف موجه التيار أو تغييره إذا لزم الأمر	- موجه التيار متسخ / متراكم عليه الجير	الماء غير كافٍ
- قم بتغيير الخرطوشة	- الخرطوشة تالفة، تراكم عليها الجير	الخلاط ثقيل الحركة
- قم بتغيير الخرطوشة	- الخرطوشة تالفة وهو مغلق	تساقط قطرات مياه من الخلاط دائماً وهو مغلق من المحبس



### الترايب راجع صفحة 31

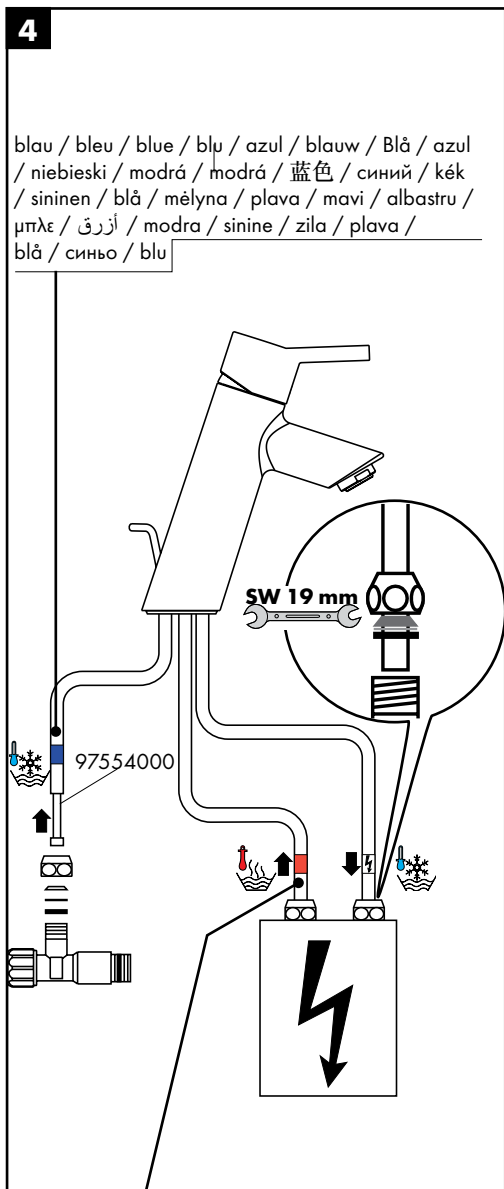
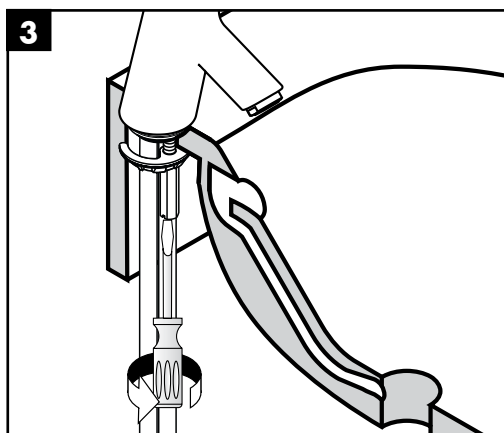
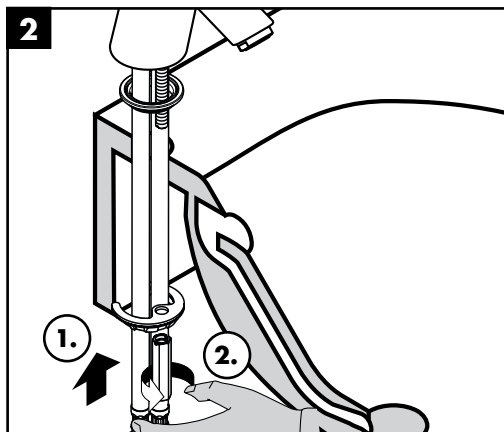
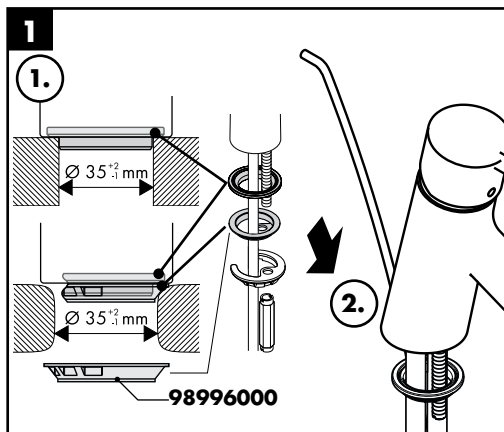

rot / rouge / red / rosso / rojo / rood / Rød / vermelho /  
 czerwony / červená / červená / 红色 / красный /  
 piros / punainen / röt / raudona / svena / kırmızı  
 / roșu / κόκκινο / أحمر / rdeča / punane / sarkana /  
 crvena / røð / червено / e kuqe



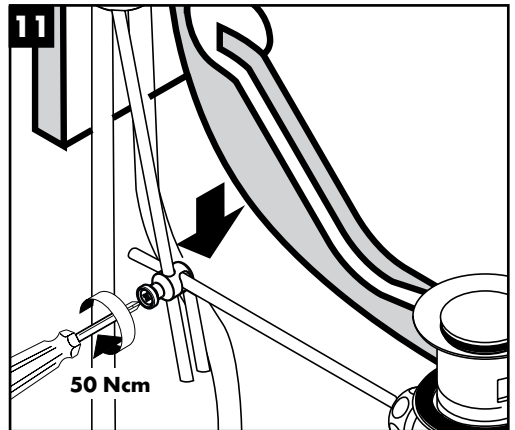
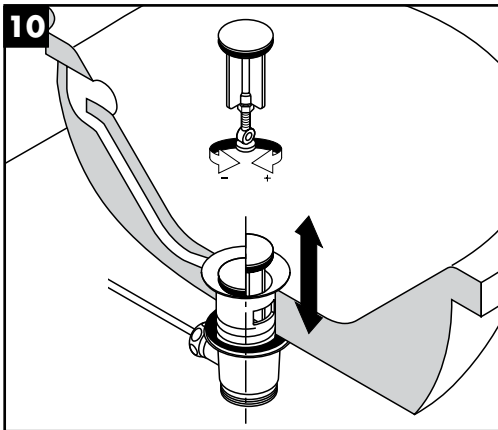
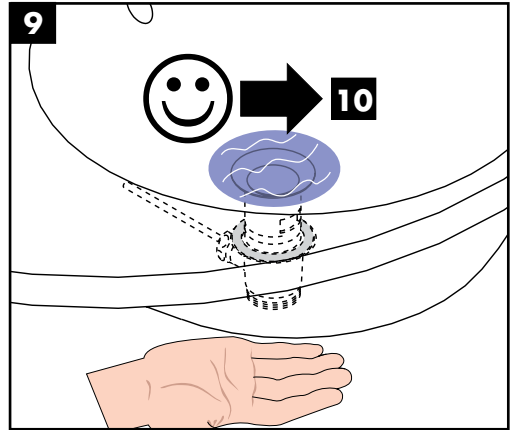
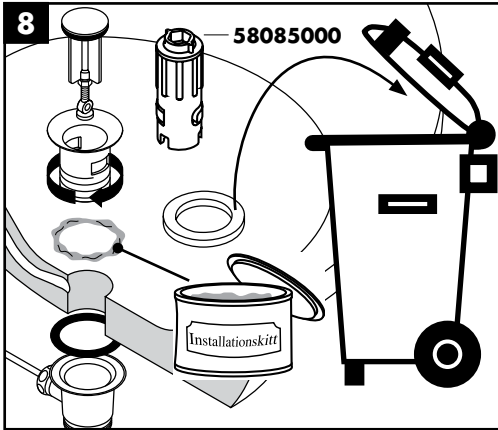
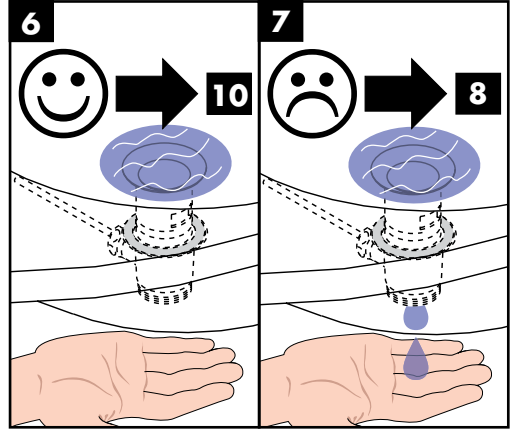
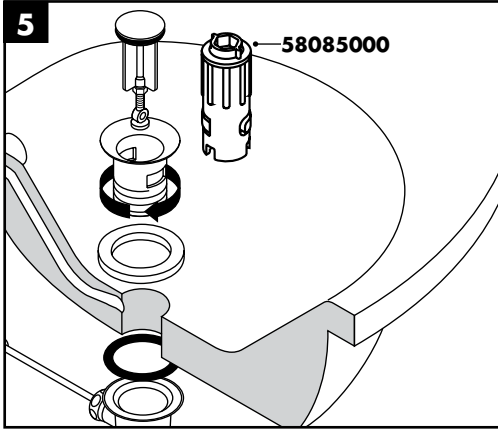

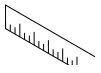

**Metropol E**  
14075XXX

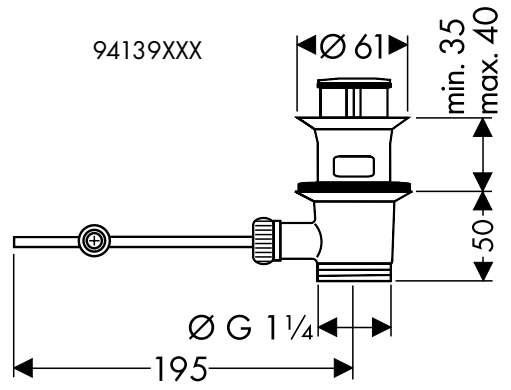
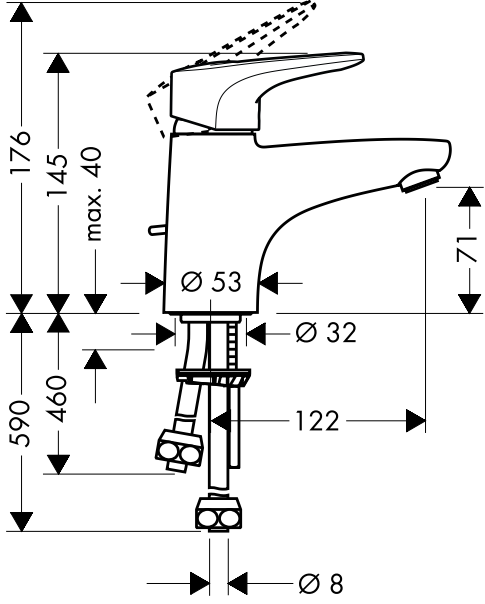

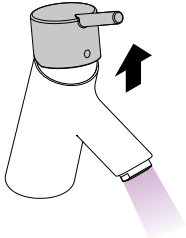

öffnen / ouvert / open / aperto / abierto / open / åbne /  
 abrir / otworzyć / otevřít / otvorit / 开 / открыть / nyitás /  
 avaaminen / öppna / atidaryti / Отваранье / açmak /  
 deschide / ανοιχτό / odpreti / avage / atvērt /  
 otvoriti / árne / отварање / hare / فتح /

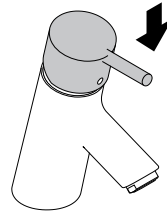

schließen / fermé / close / chiudere / cerrar / sluiten /  
 lukke / fechar / zamknąć / zavřít / uzavriet / 关 /  
 закрыть / bezárás / sulkeminen / stänga / uždaryti /  
 Zatvaranje / karatmak / închide / κλειστό /  
 zapreti / sulgege / aizvērt / zatvori / lukke / затваряне /  
 mbylle / إغلاق /

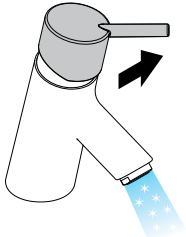

kalt / froid / cold / freddo / frío / koud / koldt / fria /  
 zimna / studená / studená / 冷 / холодная / hideg /  
 kylmä / kallit / šaltas / Hladno / soğuk / rece / κρύο /  
 mrzlo / külm / auksts / hladno / kaldt / студено / i ftohtë /  
 بارد /

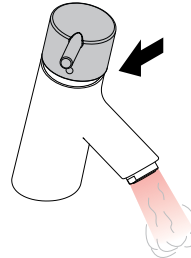

warm / chaud / hot / caldo / caliente / warm / varmt /  
 quente / ciepła / teplá / teplá / 热 / горячая / meleg /  
 lämmin / varmt / karštas / Vruća voda / sıcak / cald /  
 ζεστό / toplo / kuum / karsts / topla / varm / тепло /  
 i ngrohtë / ساخن /



P-IX

DVGW

SVGW

WRAS

KIWA

NF

ACS

ETA

14075XXX

P-IX 9871/I





**Metropol E**  
14075XXX

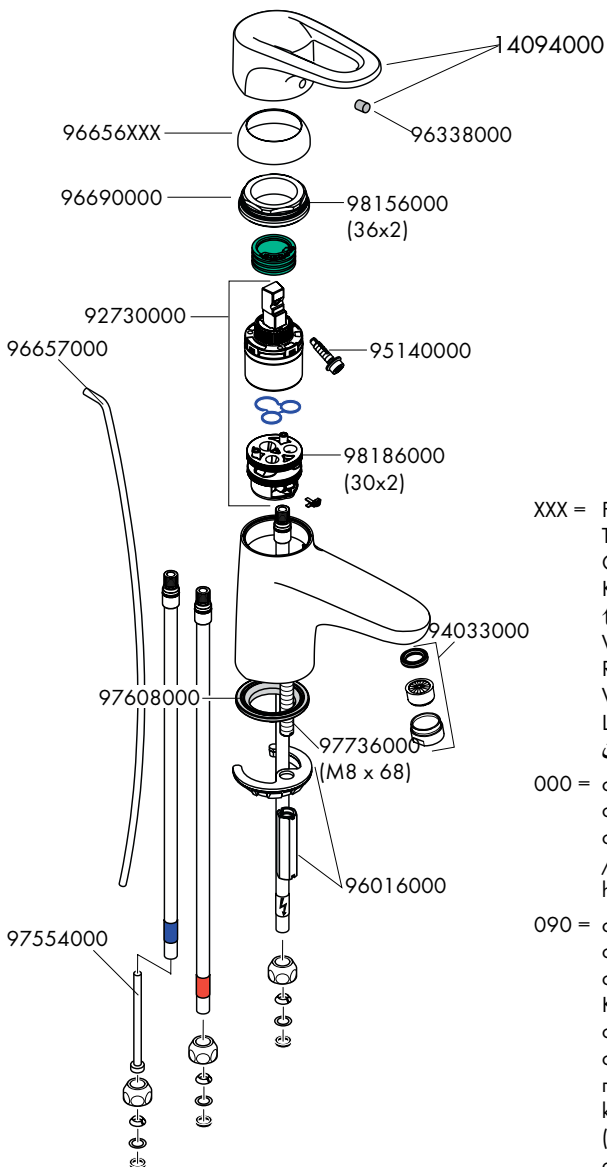

XXX = Farbcodierung / Couleurs / Colors /  
Trattamento / Acabados / Kleuren /  
Overflade / Acabamentos / Kody kolorów /  
Kód povrchové úpravy / Farebné označenie / 颜  
色代码 / Цветная кодировка / Színkódolás /  
Värikoodaus / Färgkodning / Spalvos / Boje /  
Renkler / Coduri de culori / Χρώματα / Barve /  
Värvid / Kräsü kodi / Oznake boja / Fargekode /  
Цветово кодиране / Kodimi me anë të ngjyrave /  
الألوان

000 = chrom / chromé / chrome plated / cromato /  
cromado / verchromd / Krom / cromado /  
chróm / 镀铬 / хром / króm / kromi / krom  
/ crom / Επιχρωµωµένο / kroom / hroma /  
hrom / хром / كروم

090 = chrom/gold-optik / chromé/or l'optique /  
chrome plated/gold plated / cromo/dorado  
optica / cromo/oro óptica / chroom/verguld-look /  
Krom/guld optic / cromado/ouro ótica /  
chrom/złoty szlachetna / chrom/zlato ocel /  
chróm/zlato ocel / 镀铬/黑色 / хром/  
глянцевое золото / króm/arany-hatású / kromi/  
kultaoptiikka / krom/guld-optik / chrominé  
(aukso optika) / optika krom/zlato / krom/altin-  
optik / crom/auriu optic / Επιχρωµωµένο/οπτική  
χρυσού / krom/pozlačena / kroom/kuld optik  
/ hroma/zelta / dezen hrom/zlatna / krom/  
gull-optikk / хром/оптика за zlato / krom/i  
arte-optike / كروم/لون ذهبي

---

**hansgrohe**

Hansgrohe - Postfach 1145 · D-77761 Schiltach · Telefon +49 (0) 78 36/51-1282 · Telefax +49 (0) 7836/511440  
E-Mail: [info@hansgrohe.com](mailto:info@hansgrohe.com) · Internet: [www.hansgrohe.com](http://www.hansgrohe.com)

04/2011  
9.05394.03