

DE	Gebrauchsanleitung / Montageanleitung	2
FR	Mode d'emploi / Instructions de montage	3
EN	Instructions for use / assembly instructions	4
IT	Istruzioni per l'uso / Istruzioni per Installazione	5
ES	Modo de empleo / Instrucciones de montaje	6
NL	Gebruiksaanwijzing / Handleiding	7
DK	Brugsanvisning / Monteringsvejledning	8
RU	Руководство пользователя / Инструкция по монтажу	9

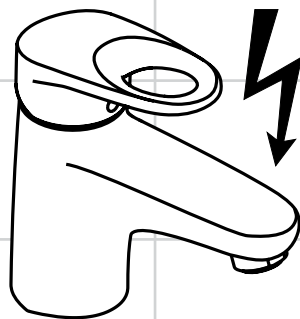

Mediano II
14024000



Ihr Online-Fachhändler für:

hansgrohe

- Kostenlose und individuelle Beratung
- Hochwertige Produkte
- Kostenloser und schneller Versand

- TOP Bewertungen
- Exzelerter Kundenservice
- Über 20 Jahre Erfahrung



E-Mail: info@unidomo.de | Tel.: 04621 - 30 60 89 0 | www.unidomo.de



Sicherheitshinweise

- Bei der Montage müssen zur Vermeidung von Quetsch- und Schnittverletzungen Handschuhe getragen werden.
- Bei 5 Liter Geräten darf die Auslaufleistung am Mischer 5 l/min nicht übersteigen. Gegebenenfalls Wasserzufuhr am Eckventil regulieren.

Montagehinweise

- Die Armatur muss nach den gültigen Normen montiert, gespült und geprüft werden!
- Kunststoffschlauch, falls notwendig, gemäß Tabelle kürzen und in das kurze, blau markierte Rohr bis zum Bund einschieben.

Technische Daten

Betriebsdruck:	max. 1 MPa
Empfohlener Betriebsdruck:	0,1 - 0,5 MPa
Prüfdruck:	1,6 MPa
(1 MPa = 10 bar = 147 PSI)	
Heißwassertemperatur:	max. 80 °C
Empfohlene Heißwassertemperatur:	65 °C
Durchflussleistung:	max. 5 l/min

Symbolerklärung



Kein essigsäurehaltiges Silikon verwenden!



Reinigung
siehe beiliegende Broschüre.



Maße (siehe Seite 12)



Bedienung (siehe Seite 13)
Beim Aufheizen des Wasserspeichers tritt am Auslauf Tropfwasser aus.



Prüfzeichen (siehe Seite 13)



Serviceteile (siehe Seite 14)
Wird der Strahlformer gewechselt, muss ein für diese Armatur zugelassener Strahlformer verwendet werden.



Sonderzubehör
Montageschlüssel (58085000) nicht im Lieferumfang enthalten



Installationskit nicht im Lieferumfang enthalten

Tabelle über die zu verwendenden Drosselschlauchlängen

Höchstmöglicher Wasserdruck am Verwendungsort in MPa	Geräteinhalt	
	8, 10 und 15 Liter	bis 5 Liter
0,1 - 0,15	ohne Drosselschlauch	Drosselschlauch auf 90 mm gekürzt
0,2 - 0,3	Drosselschlauch auf 90 mm gekürzt	Drosselschlauch unverändert
0,4 - 0,7	Drosselschlauch unverändert Durchflussmenge am Eckventil einregulieren	

Bei einem Ruhedruck über 0,5 MPa muss ein Druckminderer eingebaut werden.



Störung	Ursache	Abhilfe
Wenig Wasser	- Strahlformer verkalkt, verschmutzt	- Strahlformer reinigen, ggf. austauschen
Armatur schwergängig	- Kartusche defekt, verkalkt	- Kartusche austauschen
Armatur tropft ständig bei ausgeschaltetem Wasserbereiter	- Kartusche defekt	- Kartusche austauschen



Montage siehe Seite 10



Consignes de sécurité

-  Lors du montage, porter des gants de protection pour éviter toute blessure par écrasement ou coupure.
-  Sur les chauffe-eau à contenance de 5 litres le débit ne doit pas dépasser 5l/min, dans ce cas là, réduire le débit avec le robinet d'arrêt et d'équerre.

Instructions pour le montage

- La robinetterie doit être installée, rincée et contrôlée conformément aux normes valables!
- Raccourcir éventuellement selon les indications du tableau ci-dessous le tube platique et l'enfoncer jusqu'à la butée dans la tubulure courte avec repère bleu.

Informations techniques

Pression de service autorisée:	max. 1 MPa
Pression de service conseillée:	0,1 - 0,5 MPa
Pression maximum de contrôle:	1,6 MPa
(1 MPa = 10 bar = 147 PSI)	
Température d'eau chaude:	max. 80 °C
Température recommandée:	65 °C
Débit:	max. 5 l/min

Description du symbole

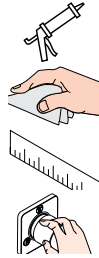

Ne pas utiliser de silicone contenant de l'acide acétique!

Nettoyage

voir la brochure ci-jointe.

Dimensions (voir page 12)

Instructions de service (voir page 13)

Le mitigeur goutte lorsque le chauffe-eau monte en température.

Classification acoustique et débit (voir page 13)

Pièces détachées (voir pages 14)

Si l'on change le aérateur, il faudra utiliser un aérateur normalisé pour cette robinetterie.

Accessoires en option

clé de montage (58085000) ne fait pas partie de la fourniture

Mastic d'installation ne fait pas partie de la fourniture

Tableau relatif aux longueurs de tube d'étranglement à utiliser

Pression d'eau maxi possible en MPa sur le lieu d'utilisation	Contenu de l'appareil	
	8, 10 et 15 litres	jusqu'à 5 litres
0,1 - 0,15	sans tube d'étranglement	Tube d'étranglement raccourci à 90 mm
0,2 - 0,3	Tube d'étranglement raccourci à 90 mm	Tube d'étranglement pas modifié
0,4 - 0,7	Tube d'étranglement pas modifié Régler le débit au niveau du robinet d'équerre	

Incorporer un réducteur de pression si la pression est supérieure à 0,5 MPa.

Dysfonctionnement

Origine

Solution



Pas assez d'eau	- Mousseur entartré ou encrassé	- Nettoyer le mousseur ou le changer éventuellement
Dureté de fonctionnement	- Cartouche défectueuse, entartrée	- Changer la cartouche
Le mitigeur goutte sans arrêt avec un chauffe-eau hors-service	- Cartouche défectueuse	- Changer la cartouche



Montage voir page 10



Safety Notes

-  Gloves should be worn during installation to prevent crushing and cutting injuries.
-  With water heaters of 5 liters the flow rate at the mixer should not exceed 5 l/min.
-  In this case the flow rate must be reduced at the isolation valve.

Installation Instructions

- The fitting must be installed, flushed and tested after the valid norms!
- If necessary shorten plastic hose according to the table and insert it up to the collar into the shorter blue marked copper pipe.

Technical Data

Operating pressure:	max. 1 MPa
Recommended operating pressure:	0,1 - 0,5 MPa
Test pressure:	1,6 MPa
(1 MPa = 10 bar = 147 PSI)	
Hot water temperature:	max. 80 °C
Recommended hot water temp.:	65 °C
Rate of flow:	max. 5 l/min

Symbol description



Do not use silicone containing acetic acid!



Cleaning

see enclosed brochure.



Dimensions (see page 12)



Operation

 (see page 13)

When the storage tank is being heated, the spout will drip.



Test certificate (see page 13)



Spare parts

 (see page 14)

When changing the spray former, it is imperative to use one made for this type of mixer.

Special accessories

special tool (58085000) order as an extra



Installation putty order as an extra



Table for the throttle hose lengths to be used

Highest possible water pressure at user's site in Mpa	Device content	
	8, 10 and 15 liters	up to 5 liters
0,1 - 0,15	without throttle hose	Throttle hose shortened to 90 mm
0,2 - 0,3	Throttle hose shortened to 90 mm	Throttle hose unchanged
0,4 - 0,7	Throttle hose unchanged Adjust flow volume at corner valve	

If the water pressure is greater than 0,5 MPa, fit a pressure reducing valve.



Fault	Cause	Remedy
Insufficient water	- Spray former calcified, dirty	- Clean spray former, exchanging if necessary
Mixer stiff	- Cartridge defective, calcified	- Exchange cartridge
Mixer dripping constantly with water heater switched off	- Cartridge defective	- Exchange cartridge



Assembly see page 10



Indicazioni sulla sicurezza

-  Durante il montaggio, per evitare ferite da schiacciamento e da taglio bisogna indossare guanti protettivi.
-  Nel caso di apparecchi da 5 litri l'erogazione del miscelatore non deve superare i 5 l/min. Eventualmente strozzare l'alimentazione d'acqua del rubinetto a squadra.

Istruzioni per il montaggio

- La rubinetteria deve essere installata, pulita e testata secondo le istruzioni riportate!
- Se necessario, tagliare il flessibile in plastica secondo la tabella e introdurlo sino allo spallamento nel tubo corto contrassegnato in blu.

Dati tecnici

Pressione d'uso:	max. 1 MPa
Pressione d'uso consigliata:	0,1 - 0,5 MPa
Pressione di prova:	1,6 MPa
(1 MPa = 10 bar = 147 PSI)	
Temperatura dell'acqua calda:	max. 80 °C
Temp. dell'acqua calda consigliata:	65 °C
Portata di erogazione:	max. 5 l/min

Descrizione simbolo



Non utilizzare silicone contenente acido acetico!



Pulitura
vedi il prospetto accluso.



Ingombri (vedi pagg. 12)



Procedura (vedi pagg. 13)
Durante il riscaldamento del serbatoio d'acqua all'uscita si ha uno stillicidio.



Segno di verifica (vedi pagg. 13)



Parti di ricambio (vedi pagg. 14)

Se si cambia il rompighetto, per questo rubinetto deve venir usato un rompighetto idoneo.

Accessori speciali



chiave per montaggio (58085000) non contenuto nel volume di fornitura



Mastice d'installazione non contenuto nel volume di fornitura

Tabella delle lunghezze dei tubi di strozzamento applicabili

Massima pressione d'acqua sul posto espressa in MPa	Contenuto dell'apparecchio	
	8, 10 e 15 litri	fino a 5 litri
0,1 - 0,15	senza tubo di strozzamento	Tubo di strozzamento ridotto a 90 mm
0,2 - 0,3	Tubo di strozzamento ridotto a 90 mm	Tubo di strozzamento non modificato
0,4 - 0,7	Tubo di strozzamento non modificato Regolare la portata tramite la valvola ad angolo	

In caso di una pressione di flusso superiore a 0,2 MPa, si deve installare un riduttore sul tubo principale.

Problema	Possibile causa	Remedio
Scarsità d'acqua	- diffusore del getto difettosa, pieno di calcare	- Pulire oppure sostituire il diffusore del getto
Miscelatore duro	- Cartuccia difettosa	- Sostituire la cartuccia
Il miscelatore perde acqua di continuo con la caldaia spenta	- Cartuccia difettosa	- Sostituire la cartuccia



Montaggio vedi pagg. 10



Indicaciones de seguridad

- ⚠ Durante el montaje deben utilizarse guantes para evitar heridas por aplastamiento o corte.
- ⚠ En caso de utilizar un calentador de 5 litros de capacidad el caudal de agua que pasa por el mezclador, no debe superar 5 l/min. En caso necesario, disminuir la entrada del agua por medio de la llave de escuadra.

Indicaciones para el montaje

- El grifo tiene que ser instalado, probado y testado, según las normas en vigor.
- En caso necesario, cortar el tubo plástico como indicado en el esquema e introducir el mismo hasta el collarín en el caño corto marcado azul.

Datos técnicos

Presión en servicio:	max. 1 MPa
Presión recomendada en servicio:	0,1 - 0,5 MPa
Presión de prueba:	1,6 MPa
(1 MPa = 10 bar = 147 PSI)	
Temperatura del agua caliente:	max. 80 °C
Temp. recomendada del agua caliente:	65 °C
Caudal máximo:	max. 5 l/min

Descripción de símbolos



No utilizar silicona que contiene ácido acético!



Limpiar
ver el folleto adjunto.



Dimensiones (ver página 12)



Manejo (ver página 13)

Al calentar el depósito de agua suelen desbordarse de la salida siempre unas gotas de agua.



Marca de verificación
(ver página 13)



Repuestos (ver página 14)

En caso de cambiar el aireador, hay que utilizar un aireador adecuado para este tipo de grifería.

Opcional



Llave de montaje (58085000) no incluido en el suministro



Masilla no incluido en el suministro

Tabla para el largo de la manguera de estrangulación aplicable

Presión de agua más alta posible en el lugar de aplicación en Mpa	Contenido del equipo	
	8,10 y 15 litros	hasta 5 litros
0,1 - 0,15	sin manguera de estrangulación	Manguera de estrangulación reducida a 90 mm
0,2 - 0,3	Manguera de estrangulación reducida a 90 mm	Manguera de estrangulación no modificada
0,4 - 0,7	Manguera de estrangulación no modificada Regulado de la cantidad de flujo en la válvula de esquina	

En condiciones de presión de reposo superior a 0,5 MPa, es imprescindible montar un reductor de presión.



Problema	Causa	Solución
Sale poca agua	- Formador de chorro ensuciado, calcificado	- Limpiar o cambiar el formador de chorro
Manecilla va dura	- cartucho dañado	- cambiar el cartucho
Grifo pierde continuamente agua con calientaguas apagado	- cartucho dañado	- cambiar el cartucho



Montaje ver página 10



Veiligheidsinstructies

-  Bij de montage moeten ter voorkoming van kniel- en snijwonden handschoenen worden gedragen.
-  Bij toestellen van 5 liter mag de uitloopcapaciteit aan de mengkraan niet hoger zijn dan 5 l/min. Indien nodig moet de watertoevoer aan de hoekstopkraan geregeld worden.

Montage-instructies

- Leidingen doorspoelen volgens Norm. De mengkraan vervolgens monteren en controleren!
- Kunststofslang, indien nodig, volgens tabel verkorten en tot aan de kraag in de korte, blauw gemarkeerde buis schuiven.

Technische gegevens

Werkdruk: max.	max. 1 MPa
Aanbevolen werkdruk:	0,1 - 0,5 MPa
Getest bij:	1,6 MPa
(1 MPa = 10 bar = 147 PSI)	
Temperatuur warm water:	max. 80 °C
Aanbevolen warm water temp.:	65 °C
Doorstroomcapaciteit:	max. 5 l/min

Symboolbeschrijving



Gebruik geen zuurhoudende siliconen!



Reinigen
zie bijgevoegde brochure.



Maten (zie blz. 12)



Bediening (zie blz. 13)

Bij het opwarmen van het waterreservoir ontsnapt aan de uitloop drupwater.



Keurmerk (zie blz. 13)



Service onderdelen (zie blz. 14)

Indien de straalvormer vervangen wordt, moet een straalvormer gebruikt worden die is toegelaten voor deze armatuur.



Toebehoren

montagesleutel (58085000) behoort niet tot het leveringspakket



Kit behoort niet tot het leveringspakket

Tabel van de te gebruiken reduceerslanglengten

Maximale waterdruk op de gebruiksplaats in MPa	Inhoud van het toestel	
	8, 10 en 15 liter	tot 5 liter
0,1 - 0,15	zonder reduceerslang	Reduceerslang verkort tot 90 mm
0,2 - 0,3	Reduceerslang verkort tot 90 mm	Reduceerslang onveranderd
0,4 - 0,7	Reduceerslang onveranderd Debiet instellen aan het hoekventiel	

Bij een statische druk van meer dan 0,5 MPa moet een drukregelaar ingebouwd worden.

Storing	Oorzaak	Oplossing
Weinig water	- Straalopeningen verkalkt, vuil	- Straalopeningen reinigen, indien nodig vervangen
Bediening zwaar	- Kardoes defect of verkalkt	- Kardoes uitwisselen
Armatuur drupt altijd bij een uitgeschakelde boiler	- Kardoes defect	- Kardoes uitwisselen



Montage zie blz. 10



Sikkerhedsanvisninger

- △ Ved monteringen skal der bruges handsker for at undgå kvæstelser og snitsår.
- △ Ved 5 litres beholdere må udløbsydelsen ved håndvaskarmaturet ikke overstige 5 liter/min. I modsat fald drosles vandet ved vandtilførslen ved hjørneventilen.

Monteringsanvisninger

- Ifølge gældende regler, skal armaturet monteres, skylles igennem og afprøves.
- Plastslange afkortes i henhold til tabellen og skubbes ind til bundet i det blåfarvede rør.

Tekniske data

Driftstryk:	max. 1 MPa
Anbefalet driftstryk:	0,1 - 0,5 MPa
Prøvetryk:	1,6 MPa
(1 MPa = 10 bar = 147 PSI)	
Varmtvandstemperatur:	max. 80 °C
Anbefalet varmtvandstemperatur:	65 °C
Gennemstrømningskapacitet:	max. 5 l/min

Symbolbeskrivelse



Der må ikke benyttes eddikesyreholdig silikone!



Rengøring
se venligst den vedlagte brochure.



Målene (se s. 12)



Brugsanvisning (se s. 13)
Ved opvarmning af varmtvandsbeholderen forekommer dryp fra udløbstudten.



Godkendelse (zie blz. 13)



Reserve dele (se s. 14)
Ved skift af stråleformerer, skal der anvendes en stråleformerer, som er godkendt til dette armatur

Specialtilbehør



Monteringsnøgle (58085000) ikke med i leveringsomfang



Kitt ikke med i leveringsomfang

Tabel over de drosselslangelængder, som skal bruges

Højst muligt vandtryk på brugsstedet i MPa	Enhedens indhold	
	8, 10 og 15 liter	op til 5 liter
0,1 - 0,15	uden drosselslange	Drosselslange afkortet til 90 mm
0,2 - 0,3	Drosselslange afkortet til 90 mm	Drosselslange uforandret
0,4 - 0,7	Drosselslange uforandret Juster gennemstrømningsmængden på hjørneventilen	



Ved et rørtryk på mere end 0,5 MPa, skal trykket reduceres.

Fejl	Årsag	Hjælp
For lidt vand	- Stråleformer forkalket, tilsmudset	- Stråleformer renses, skiftes i givet fald ud
Grebet går trægt	- Kartusche defekt, tilkalket	- Udskift kartusche
Armatur drypper hele tiden ved slukket vandvarmer	- Defekt kartusche	- Udskift kartusche





Указания по технике безопасности

-  Во время монтажа следует надеть перчатки во избежание прищемления и порезов.
-  Для 5-литровых приборов производительность выхода на смесителе не должна превышать 5 л/мин. При необходимости отрегулируйте подачу воды на угловом вентиле

Указания по монтажу

- Смеситель должен быть смонтирован по действующим нормам и в соответствии с настоящей инструкцией, проверен на герметичность и безупречность работы
- Пластмассовый шланг, если необходимо, укоротите, согласно таблице и вставьте в короткую трубу с синей маркировкой до буртика.

Технические данные

Рабочее давление: не более. 1 МПа
 Рекомендуемое рабочее давление: 0,1 - 0,5 МПа
 Давления: 1,6 МПа
 (1 МПа = 10 bar = 147 PSI)
 Температура горячей воды: не более. 80 °С
 Рекомендуемая темп. гор. воды: 65 °С
 Пропускная способность: не более. 5 л/мин

Описание символов



Не применяйте силикон, содержащий уксусную кислоту.



Очистка
см прилагаемая брошюра



Размеры (см. стр. 12)



Эксплуатация (см. стр. 13)

При подогреве водяного резервуара из выхода капает вода.



Знак технического контроля
(см. стр. 13)



Комплект (см. стр. 14)

При замене формирователя струи необходимо использовать формирователь струи, предназначенный для этой арматуры.



Специальные принадлежности

Монтажный ключ (58085000) не включено в объем поставки!



Монтаж подводки не включено в объем поставки!

Таблица длин используемых шлангов дросселя

Максимальное давление воды на участке применения в МПа	Емкость устройств	
	8, 10 и 15 литров	до 5 литров
0,1 - 0,15	Без шланга дросселя	Шланг дросселя укороченный, длина 90 мм
0,2 - 0,3	Шланг дросселя укороченный, длина 90 мм	Шланг дросселя неизменной длины
0,4 - 0,7	Шланг дросселя неизменной длины отрегулируйте расход воды на угловом клапане	

При статическом давлении более 0,5 МПа необходимо устанавливать редукционный клапан.

Неисправность

Причина

Устранение неисправности

недостаточный давление (если устан напор воды)	- Формирователь струи имеет известковые отложения/загрязнен	- Очистите формирователь струи, по мере необходимости замените
Арматура работает с усилием	- Картридж неисправен, засорение накипью	- Замените картридж
Из арматуры при подключенном водонагревателе постоянно капает вода	- Картридж неисправен	- Замените картридж



Монтаж см. стр. 10

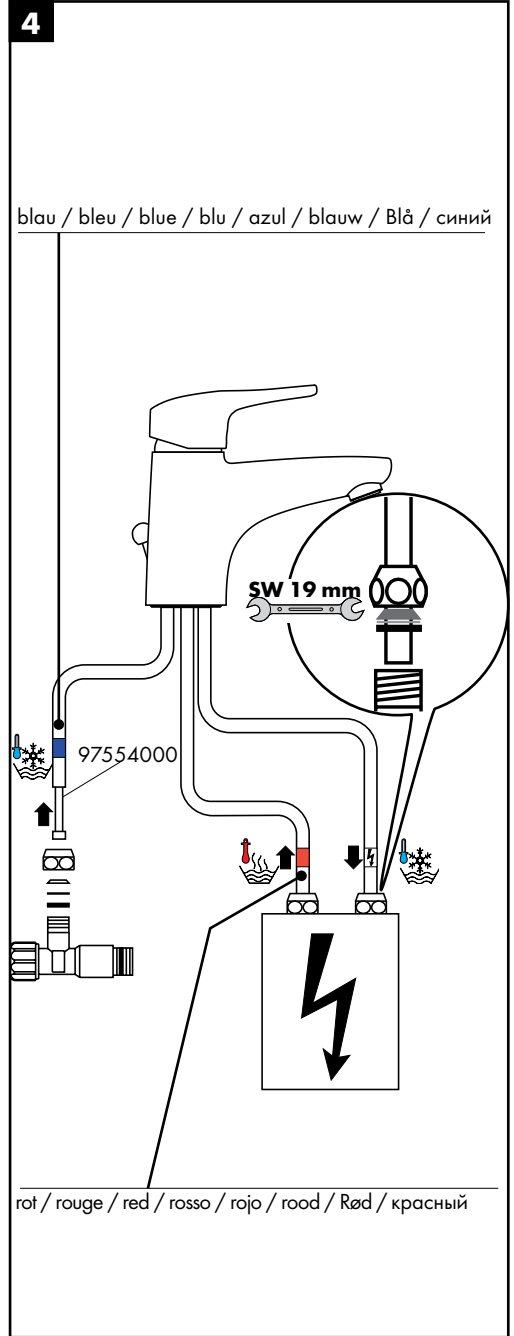
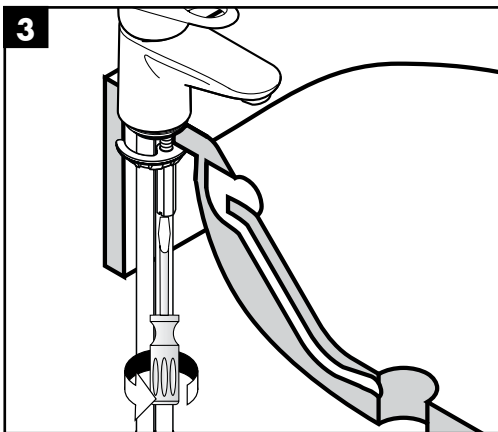
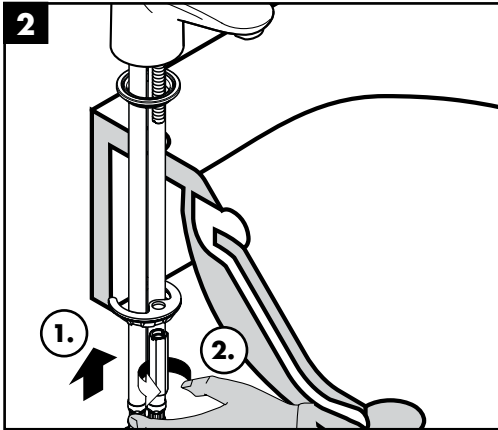
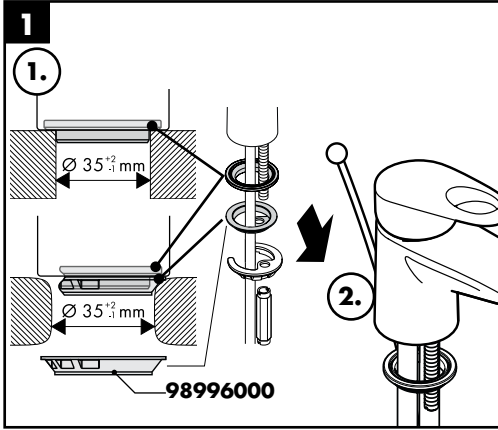

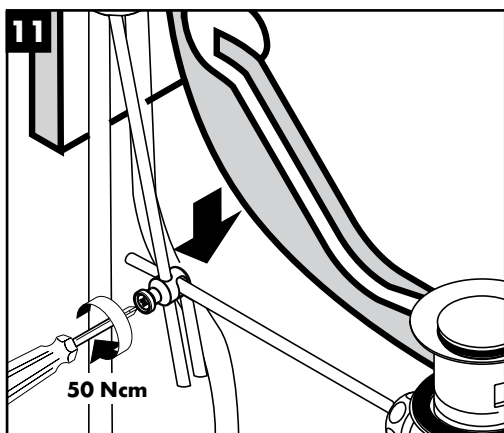
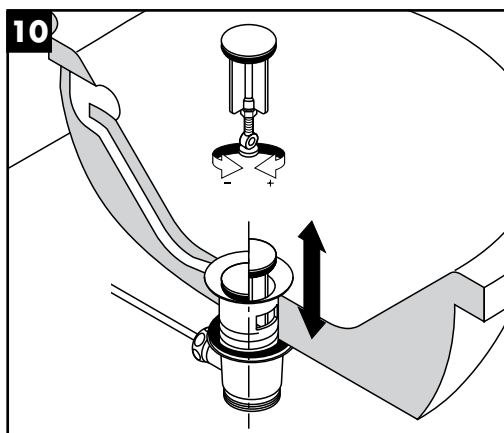
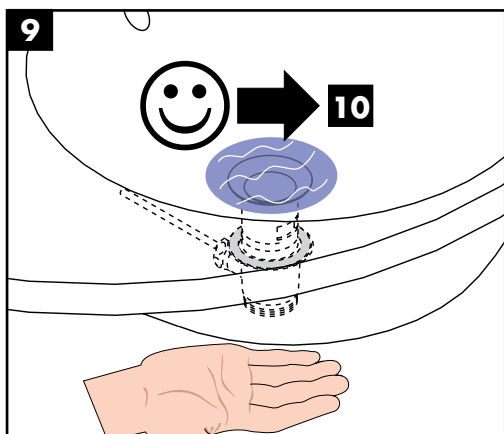
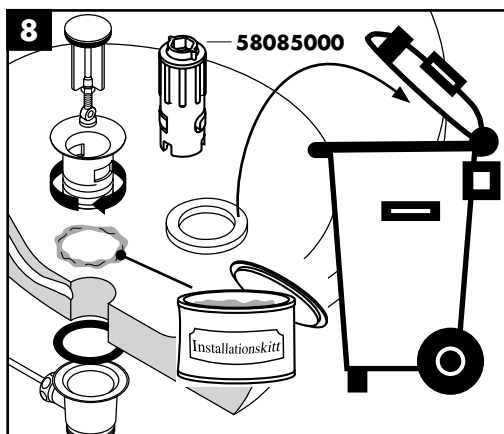
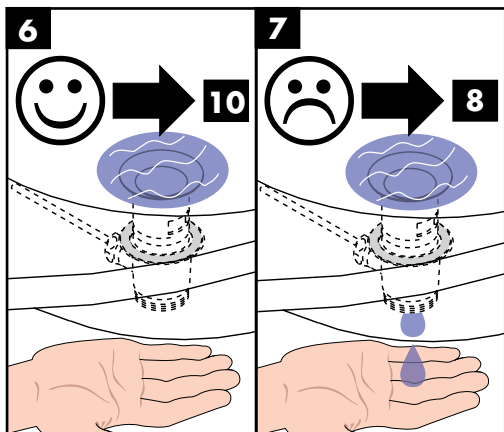
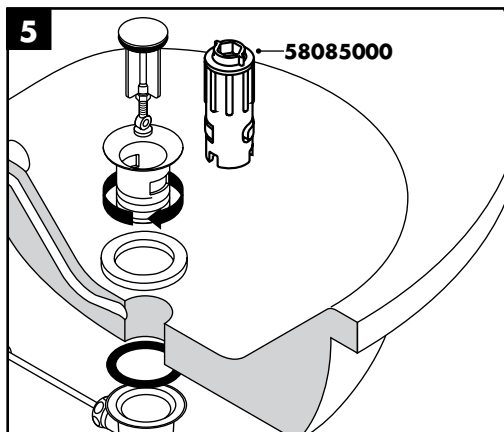



Mediano II

14024000

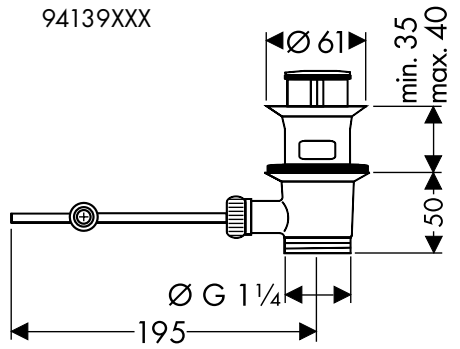
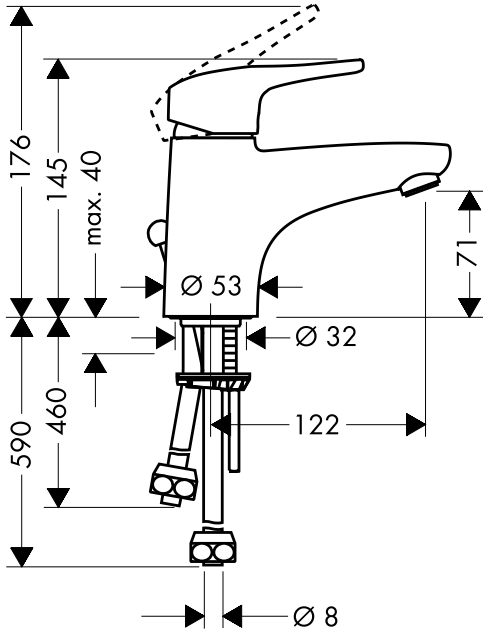

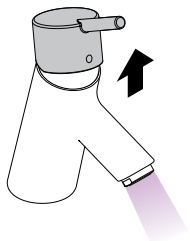

öffnen / ouvert / open / aperto / abierto / open /
åbne / открыть

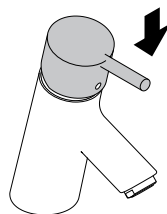

schließen / fermé / close / chiudere / cerrar / sluiten /
lukke / закрыть

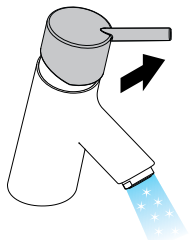

kalt / froid / cold / freddo / frío / koud /
koldt / холодная

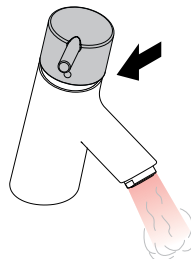

warm / chaud / hot / caldo / caliente / warm /
varmt / орячая



P-IX

DVGW

SVGW

WRAS

KIWA

NF

ACS

ETA

14024000

P-IX 9871/I





Mediano II

14024000

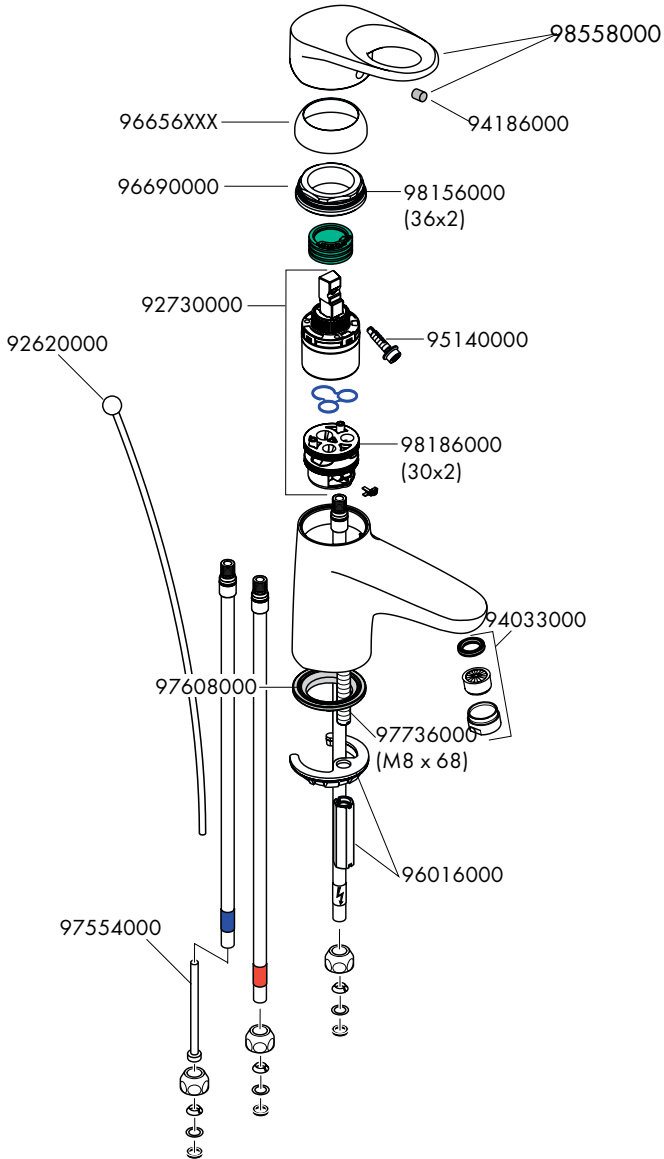



hansgrohe

Hansgrohe - Postfach 1145 · D-77761 Schiltach · Telefon +49 (0) 78 36/51-1282 · Telefax +49 (0) 7836/511440
E-Mail: info@hansgrohe.com · Internet: www.hansgrohe.com

04/2011
9.0516703