

Installation Instruction / Warranty

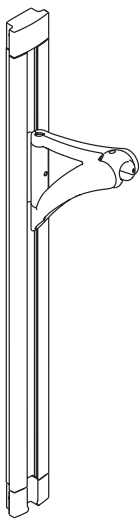

Raindance Unica
27598XXX

hansgrohe



Ihr Online-Fachhändler für:

hansgrohe

- Kostenlose und individuelle Beratung
- Hochwertige Produkte
- Kostenloser und schneller Versand

- TOP Bewertungen
- Exzelerter Kundenservice
- Über 20 Jahre Erfahrung



E-Mail: info@unidomo.de | Tel.: 04621 - 30 60 89 0 | www.unidomo.de

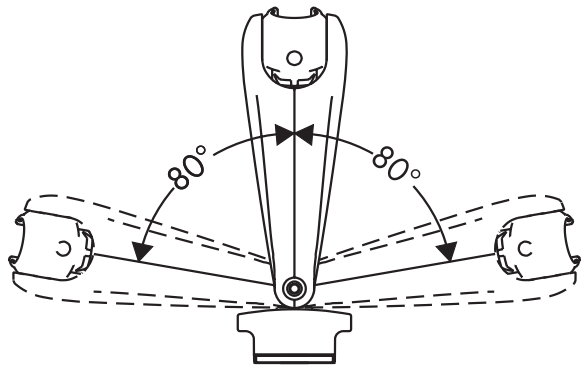
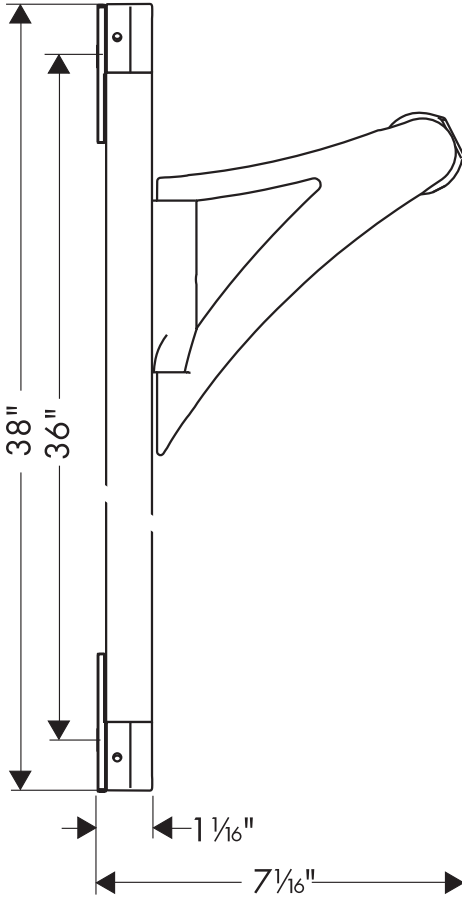

Installation

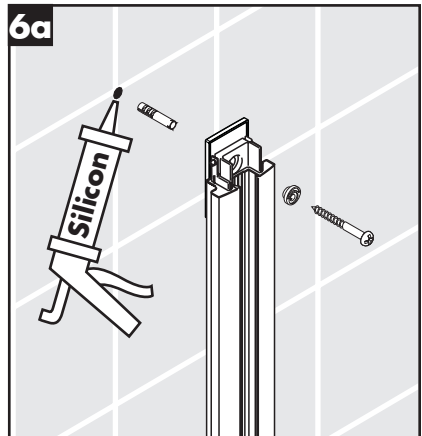
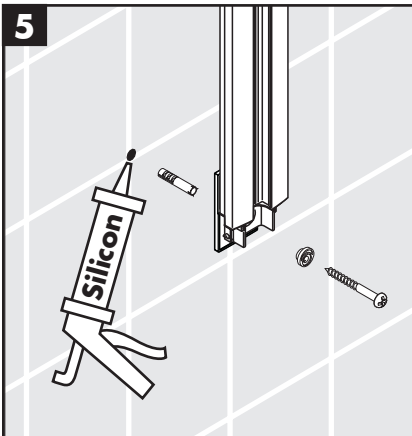
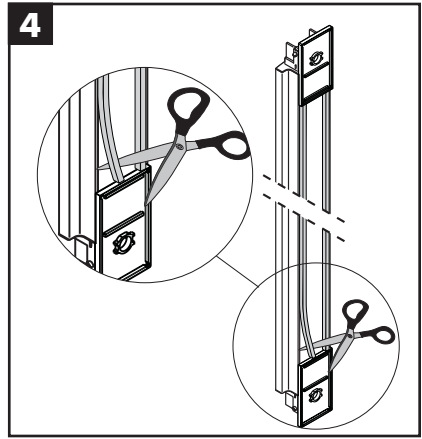
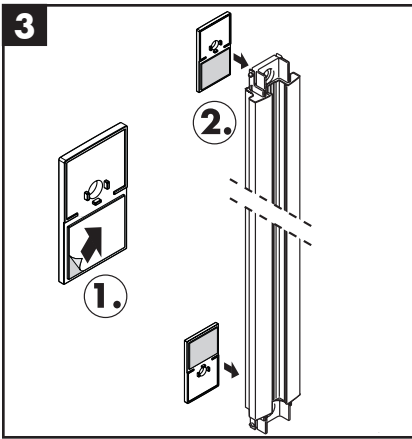
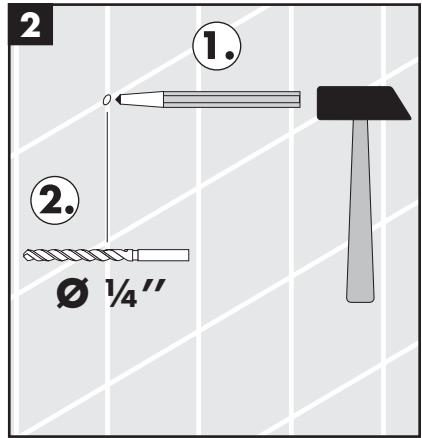
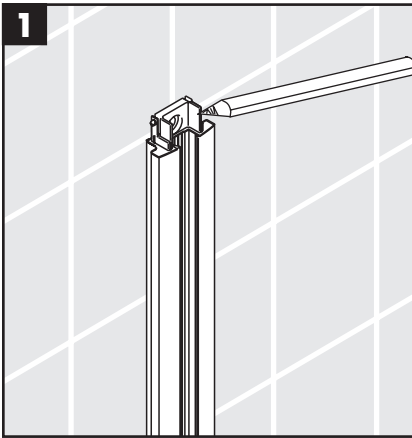

Installation

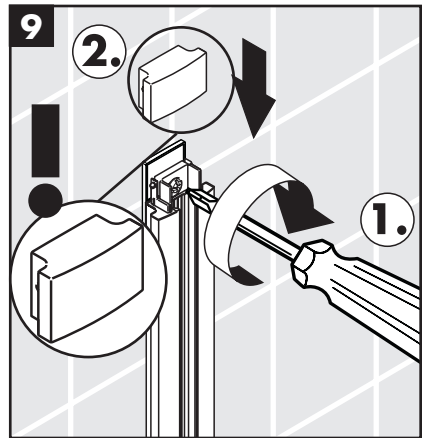
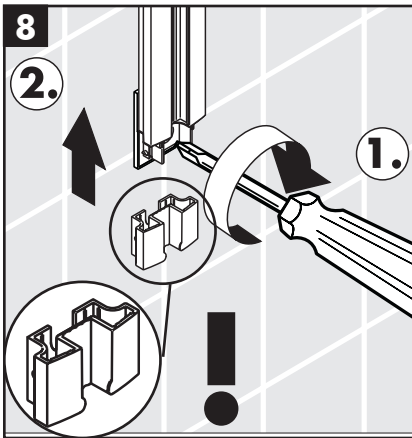
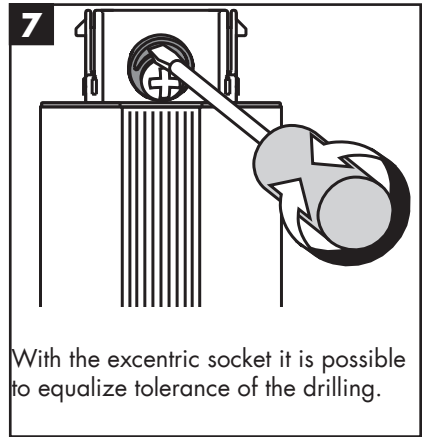
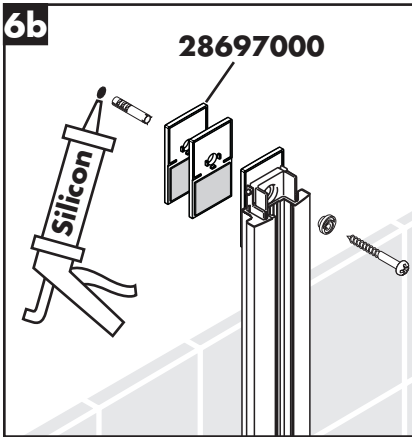

Important!

Optimal functioning is only guaranteed with the combination of Hansgrohe handshowers and Hansgrohe shower hoses. Shower hoses are only suitable for a connection from the shower to the fitting. Never fit a shut-off device between the fitting and the hose.

Adjustment

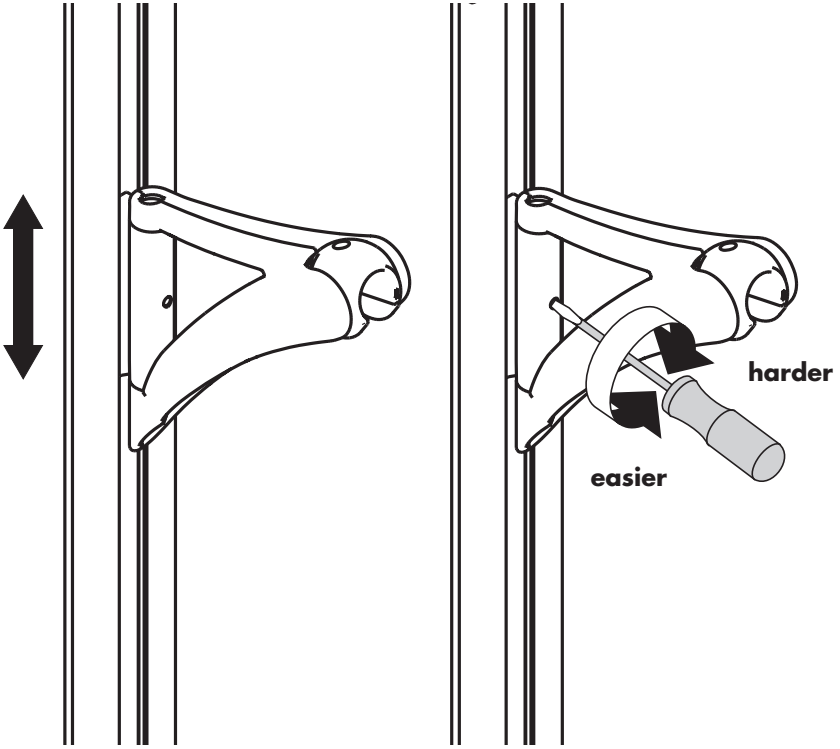

Cleaning Recommendation for Hansgrohe Products

Modern faucetry and shower products utilize a combination of materials to comply with the needs of the market with regard to design and functionality.

To avoid damage, it is necessary to use some caution when cleaning. Damage caused by improper treatment is not covered under the Hansgrohe warranty.

Cleaning Materials for Faucets and Showers

- To remove lime scale, use only products made specifically for that purpose. Always follow the manufacturer's instructions when using.
- Do not use cleaners that contain hydrochloric, formic, acetic, or phosphoric acids, as these will cause considerable damage to finishes and to plastic components.
- Never mix cleaning materials.
- Never use cleaners containing abrasives. Do not use abrasive cleaning cloths, pads, or sponges.

Cleaning Procedures

- Clean your faucets and shower products as and when required. Regular cleaning will prevent scale buildup and water spotting.
- Follow the label instructions. Do not allow any cleaner to remain on the product for longer than necessary.
- When using spray cleaners, spray first onto a sponge or cloth – do not spray directly onto the product.
- After cleaning, rinse thoroughly with clear water to remove any cleaner residue.

Important

- Soap and shampoo residue can also cause damage to the product. Rinse well with clean water after use.
- If the surface is already damaged, harsh cleaning materials will cause further damage.

Hansgrohe Consumer Warranty

Hansgrohe products are manufactured and tested to the highest quality standards. Hansgrohe, Inc. warrants to the original consumer that its products will be free from defects of workmanship and materials for as long as the original consumer owns the home in which the products are installed. Accessories or parts of products manufactured by others are warranted only for the period and to the extent of the original manufacturer's warranty.

This warranty applies only to products purchased for consumer use. Products purchased for commercial, industrial or business use are covered under a separate one-year warranty. **This warranty does not cover installation or any other labor charges associated with the repair or reinstallation of Hansgrohe products. This express warranty does not apply to products that have been damaged due to misuse, abuse, negligence, accident, faulty installation, use of abrasive or caustic cleaners, poor maintenance practices or use in any manner contrary to the written instructions provided.**

Hansgrohe, Inc. will repair or replace, at its option, free of charge during the warranty period, any part which proves to be defective in material and/or workmanship under normal installation, use, service and maintenance. If Hansgrohe, Inc. is unable to provide a replacement and repair is not practical or cannot be made in a timely manner, Hansgrohe, Inc. will refund the purchase price in exchange for return of the product. THIS REMEDY IS THE SOLE AND EXCLUSIVE REMEDY TO THE PURCHASER FOR THE BREACH OF ANY WARRANTIES OR NEGLIGENCE BY HANSGROHE, INC.

For assistance, simply notify your Hansgrohe dealer or write to: Customer Service, Hansgrohe, Inc., 1490 Bluegrass Lakes Pkwy, Alpharetta, GA 30004. Include the original receipt with a description of problem, model number and your name and address. Hansgrohe may, at its option, require you to send the defective part of the product prepaid for inspection prior to replacement.

This warranty is limited to the above; and this warranty and any warranties implied by state law, including the implied warranty of merchantability, apply only to products purchased after March 1, 1996. This warranty gives you specific legal rights; you may also have other rights which vary from state to state. Unless otherwise contrary to state law governing the purchase, Hansgrohe, Inc. liability will not exceed the contract price for the product claimed to be defective or unsuitable and is applicable only to products purchased through Hansgrohe, Inc. and installed in the United States or Canada.

hansgrohe

AÏOR | PHÂRO

Hansgrohe Inc. 1490 Bluegrass Lakes Parkway Alpharetta GA 30004
Phone 770 360 9880 Internet www.Hansgrohe-USA.com