

DE	Gebrauchsanleitung / Montageanleitung	2
FR	Mode d'emploi / Instructions de montage	3
EN	Instructions for use / assembly instructions	4
IT	Istruzioni per l'uso / Istruzioni per Installazione	5
ES	Modo de empleo / Instrucciones de montaje	6
NL	Gebruiksaanwijzing / Handleiding	7
DK	Brugsanvisning / Monteringsvejledning	8
PT	Instruções para uso / Manual de Instalação	9
PL	Instrukcja obsługi / Instrukcja montażu	10
CS	Návod k použití / Montážní návod	11
SK	Návod na použitie / Montážny návod	12
ZH	用户手册 / 组装说明	13
RU	Руководство пользователя / Инструкция по монтажу	14
HU	Használati útmutató / Szerelési útmutató	15
FI	Käyttöohje / Asettusohje	16
SV	Bruksanvisning / Monteringsanvisning	17
LT	Vartotojo instrukcija / Montavimo instrukcijos	18
HR	Upute za uporabu / Uputstva za instalaciju	19
TR	Kullanım kılavuzu / Montaj kılavuzu	20
RO	Manual de utilizare / Instrucțiuni de montare	21
EL	Οδηγίες χρήσης / Οδηγία συναρμολόγησης	22
SI	Navodilo za uporabo / Navodila za montažo	23
ET	Kasutusjuhend / Paigaldusjuhend	24
LV	Lietošanas pamācība / Montāžas instrukcija	25
SR	Uputstvo za upotrebu / Uputstvo za montažu	26
NO	Bruksanvisning / Montasjeveiledning	27
BG	Инструкция за употреба / Инструкция за употреба	28
SQ	Udhëzuesi i përdorimit / Udhëzime rreth montimit	29
AR	دليل الاستخدام / تعليمات التجميع	30

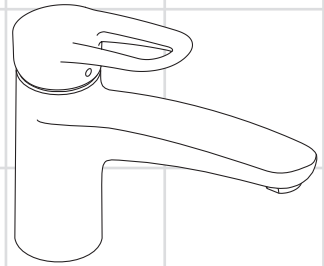

Metropol
14830000

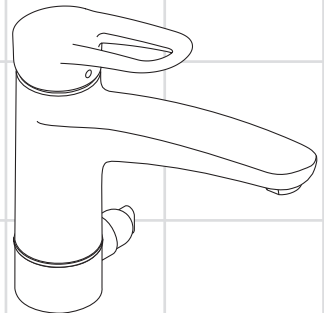

Metropol
14835000



Ihr Online-Fachhändler für:

hansgrohe

- Kostenlose und individuelle Beratung
- Hochwertige Produkte
- Kostenloser und schneller Versand

- TOP Bewertungen
- Exzelerter Kundenservice
- Über 20 Jahre Erfahrung



E-Mail: info@unidomo.de | Tel.: 04621 - 30 60 89 0 | www.unidomo.de



Sicherheitshinweise

- ⚠ Bei der Montage müssen zur Vermeidung von Quetsch- und Schnittverletzungen Handschuhe getragen werden.
- ⚠ Große Druckunterschiede zwischen den Kalt- und Warmwasseranschlüssen müssen ausgeglichen werden.
- ⚠ 14835000: Nur Spül- oder Waschmaschinen die das DVGW-Zeichen führen, dürfen ohne Zusatzsicherung an das Geräteanschlussventil angeschlossen werden. Wird kein Verbraucher an das Geräteanschlussventil angeschlossen, muss dieses abgestopft werden.

Montagehinweise

- Die Armatur muss nach den gültigen Normen montiert, gespült und geprüft werden!

Technische Daten

Betriebsdruck:	max. 1 MPa
Empfohlener Betriebsdruck:	0,1 - 0,5 MPa
Prüfdruck:	1,6 MPa
(1 MPa = 10 bar = 147 PSI)	
Heißwassertemperatur:	max. 80 °C
Empfohlene Heißwassertemperatur:	65 °C

Symbolerklärung



Einhandmischer mit Warmwasserbegrenzung, Justierung siehe Seite 36. In Verbindung mit Durchlauferhitzern ist eine Warmwassersperre nicht notwendig.



Kein essigsäurehaltiges Silikon verwenden!



Maße (siehe Seite 32)



Durchflussdiagramm (siehe Seite 33)



Serviceteile (siehe Seite 35)



Bedienung (siehe Seite 34)



Prüfzeichen (siehe Seite 33)



Reinigung

siehe beiliegende Broschüre.



Montage siehe Seite 31



Consignes de sécurité

- ⚠ Lors du montage, porter des gants de protection pour éviter toute blessure par écrasement ou coupure.
- ⚠ Il est conseillé d'équilibrer les pressions de l'eau chaude et froide.
- ⚠ 14835000: Seuls les lave-vaisselle ou machines à laver portant le sigle DVGW, doivent être reliés sans fusible supplémentaire au raccord de l'appareil. Si aucun consommateur n'est relié à la valve-raccord de l'appareil, cette dernière doit être obturée.

Instructions pour le montage

- La robinetterie doit être installée, rincée et contrôlée conformément aux normes valables!

Informations techniques

Pression de service autorisée:	max. 1 MPa
Pression de service conseillée:	0,1 - 0,5 MPa
Pression maximum de contrôle: (1 MPa = 10 bar = 147 PSI)	1,6 MPa
Température d'eau chaude:	max. 80 °C
Température recommandée:	65 °C

Description du symbole



Mitigeur avec limitation de la température: consulter la page 36 pour le réglage. Une limitation de la température n'est pas nécessaire quand le mitigeur est alimenté par un chauffe-eau instantané.



Ne pas utiliser de silicone contenant de l'acide acétique!



Dimensions (voir page 32)



Diagramme du débit (voir page 33)



Pièces détachées (voir pages 35)



Instructions de service (voir page 34)



Classification acoustique et débit (voir page 33)



Nettoyage

voir la brochure ci-jointe.



Montage voir page 31



Safety Notes

- ⚠️ Gloves should be worn during installation to prevent crushing and cutting injuries.
- ⚠️ The hot and cold supplies must be of equal pressures.
- ⚠️ 14835000: Only dishwashers and washing machines certified with the DVGW emblem may be connected to the appliance connection valve without an additional fuse. If no consumer is connected to the appliance connection valve, it must be plugged.

Installation Instructions

- The fitting must be installed, flushed and tested after the valid norms!

Technical Data

Operating pressure:	max. 1 MPa
Recommended operating pressure:	0,1 - 0,5 MPa
Test pressure:	1,6 MPa
(1 MPa = 10 bar = 147 PSI)	
Hot water temperature:	max. 80 °C
Recommended hot water temp.:	65 °C

Symbol description



To adjust the hot water limiter on single lever mixers, please see page 36. No adjustment is necessary when using a continuous flow water heater.



Do not use silicone containing acetic acid!



Dimensions (see page 32)



Flow diagram (see page 33)



Spare parts (see page 35)



Operation (see page 34)



Test certificate (see page 33)



Cleaning



see enclosed brochure.



Assembly see page 31



Indicazioni sulla sicurezza

-  Durante il montaggio, per evitare ferite da schiacciamento e da taglio bisogna indossare guanti protettivi.
-  Attenzione! Compensare le differenze di pressione tra i collegamenti dell'acqua fredda e dell'acqua calda.
-  14835000: Solo le lavastoviglie e lavatrici con il marchio DVGW si possono collegare senza fusibile supplementare con la valvola di collegamento dell'apparecchio. Nel caso in cui non si collega un apparecchio con la valvola di collegamento, la valvola deve essere chiusa con l'apposito tappo.

Istruzioni per il montaggio

- La rubinetteria deve essere installata, pulita e testata secondo le istruzioni riportate!

Dati tecnici

Pressione d'uso:	max. 1 MPa
Pressione d'uso consigliata:	0,1 - 0,5 MPa
Pressione di prova:	1,6 MPa
(1 MPa = 10 bar = 147 PSI)	
Temperatura dell'acqua calda:	max. 80 °C
Temp. dell'acqua calda consigliata:	65 °C

Descrizione simbolo



Regolazione del limitatore di erogazione di acqua calda dei miscelatori monocomando, vedere pagina 36. In combinazione con le caldaie istantanee, il limitatore di erogazione di acqua calda non è necessario.



Non utilizzare silicone contenente acido acetico!



Ingombri (vedi pagg. 32)



Diagramma flusso (vedi pagg. 33)



Parti di ricambio (vedi pagg. 35)



Procedura (vedi pagg. 34)



Segno di verifica (vedi pagg. 33)



Pulitura

vedi il prospetto accluso.



Montaggio vedi pagg. 31



Indicaciones de seguridad

- ⚠ Durante el montaje deben utilizarse guantes para evitar heridas por aplastamiento o corte.
- ⚠ Grandes diferencias de presión en servicio entre agua fría y agua caliente deben equilibrarse.
- ⚠ 14835000: Sin seguro adicional, solo está permitido conectar a la válvula de conexión de aparatos, los lavavajillas y las lavadoras que lleven incorporado el sello DVGW (Asociación alemana de especialistas en instalaciones de gas y agua). Si no se va a conectar ningún dispositivo consumidor a la válvula de conexión de aparatos, entonces esta deberá taparse con prensaestopas.

Indicaciones para el montaje

- El grifo tiene que ser instalado, probado y testado, según las normas en vigor.

Datos técnicos

Presión en servicio:	max. 1 MPa
Presión recomendada en servicio:	0,1 - 0,5 MPa
Presión de prueba: (1 MPa = 10 bar = 147 PSI)	1,6 MPa
Temperatura del agua caliente:	max. 80 °C
Temp. recomendada del agua caliente:	65 °C

Descripción de símbolos



Uso como mezclador monomando con limitación del caudal de agua caliente: ver ajuste en página 36. En combinación con calentadores instantáneos no es necesario limitar el caudal de agua caliente.



No utilizar silicona que contiene ácido acético!



Dimensiones (ver página 32)



Diagrama de circulación (ver página 33)



Repuestos (ver página 35)



Manejo (ver página 34)



Marca de verificación (ver página 33)



Limpiar

ver el folleto adjunto.



Montaje ver página 31



Veiligheidsinstructies

- ⚠ Bij de montage moeten ter voorkoming van kniel- en snijwonden handschoenen worden gedragen.
- ⚠ Grote drukverschillen tussen de kouden warm wateraansluitingen dienen vermeden te worden.
- ⚠ 14835000: Enkel vaatwas- of wasmachines die beschikken over het DVGW-kenmerk, mogen zonder extra beveiliging aangesloten worden aan de aansluitklep van het apparaat. Indien geen verbruiker aan de aansluitklep van het apparaat wordt aangesloten, moet die afgesloten worden.

Montage-instructies

- Leidingen doorspoelen volgens Norm. De mengkraan vervolgens monteren en controleren!

Technische gegevens

Werkdruk: max.	max. 1 MPa
Aanbevolen werkdruk:	0,1 - 0,5 MPa
Getest bij:	1,6 MPa
(1 MPa = 10 bar = 147 PSI)	
Temperatuur warm water:	max. 80 °C
Aanbevolen warm water temp.:	65 °C

Symboolbeschrijving



Eéngreepsmengkranen met warmwaterbegrenzing, instelling zie blz. 36. In combinatie met geisers is een warmwaterbegrenzing niet noodzakelijk.



Gebruik geen zuurhoudende silicone!



Maten (zie blz. 32)



Doorstroombiagram (zie blz. 33)



Service onderdelen (zie blz. 35)



Bediening (zie blz. 34)



Keurmerk (zie blz. 33)



Reinigen

zie bijgevoegde brochure.



Montage zie blz. 31



Sikkerhedsanvisninger

- ⚠ Ved monteringen skal der bruges handsker for at undgå kvæstelser og snitsår.
- ⚠ Større trykforskelte mellem koldt og varmt vand bør udjævnes.
- ⚠ 14835000: Du må kun tilslutte opvaksemaskiner og vaskemaskiner med DVGW-tegn uden ekstra sikring til apparatets tilslutningsventil. Hvis der ikke tilsluttes en forbruger til apparatets tilslutningsventil, skal ventilen lukkes med en prop.

Monteringsanvisninger

- Ifølge gældende regler, skal armaturet monteres, skylles igennem og afprøves.

Tekniske data

Driftstryk:	max. 1 MPa
Anbefalet driftstryk:	0,1 - 0,5 MPa
Prøvetryk: (1 MPa = 10 bar = 147 PSI)	1,6 MPa
Varmtvandstemperatur:	max. 80 °C
Anbefalet varmtvandstemperatur:	65 °C

Symbolbeskrivelse



Etgrebsarmaturer med varmtvandsbegrænsning, justering se side 36. I forbindelse med gennemstrømningsvandvarmer er en varmtvandsbegrænsning ikke nødvendig.



Der må ikke benyttes eddikesyreholdig silikone!



Målene (se s. 32)



Gennemstrømningsdiagram (se s. 33)



Reservedele (se s. 35)



Brugsanvisning (se s. 34)



Godkendelse (zie blz. 33)



Rengøring

se venligst den vedlagte brochure.



Montering se s. 31



Avisos de segurança

- ⚠ Durante a montagem devem ser utilizadas luvas de protecção, de modo a evitar ferimentos resultantes de entalamentos e de cortes.
- ⚠ Grandes diferenças entre as pressões das águas quente e fria devem ser compensadas.
- ⚠ 14835000: Apenas as máquinas de lavar loiça ou as máquinas de lavar roupa que têm a posto o símbolo DVGW podem ser conectadas à válvula de ligação do aparelho, sem a utilização de um dispositivo de protecção complementar. Se a válvula de ligação do aparelho não for conectada a nenhum consumidor é necessário fechá-la.

Avisos de montagem

- A misturadora deve ser instalada, purgada e testada de acordo com as normas em vigor!

Dados Técnicos

Pressão de funcionamento:	max. 1 MPa
Pressão de func. recomendada:	0,1 - 0,5 MPa
Pressão testada:	1,6 MPa
(1 MPa = 10 bar = 147 PSI)	
Temperatura da água quente:	max. 80 °C
Temp. água quente recomendada:	65 °C

Descrição do símbolo



Misturadora monocomando equipada com limitador de temperatura (vide pàg. 36). Em combinação com caldeira ou esquentador instantâneo o limitador de água quente não se aplica.



Não utilizar silicone que contenha ácido acético!



Medidas (ver página 32)



Fluxograma (ver página 33)



Peças de substituição (ver página 35)



Funcionamento (ver página 34)



Marca de controlo (ver página 33)



Limpeza

consultar a seguinte brochura.



Montagem ver página 31



Wskazówki bezpieczeństwa

- ⚠ Aby uniknąć zranień, takich jak zgniecenia czy przecięcia, podczas montażu należy nosić rękawice.
- ⚠ Znaczne różnice ciśnień na dopływach ciepłej i zimnej wody muszą zostać wyrównane.
- ⚠ 14835000: Bez dodatkowego zabezpieczenia do zaworu przyłączeniowego urządzenia można podłączyć jedynie zmywarkę lub pralkę posiadającą znaczek DVGW. Gdy do zaworu przyłączeniowego urządzenia nie podłącza się żadnego odbiornika, należy go zaślepić.

Wskazówki montażowe

- Armatura musi być zamontowana, przepłukana i wypróbowana według obowiązujących norm!

Dane techniczne

Ciśnienie robocze:	maks. 1 MPa
Zalecane ciśnienie robocze:	0,1 - 0,5 MPa
Ciśnienie próbne:	1,6 MPa
(1 MPa = 10 bary = 147 PSI)	
Temperatura wody gorącej:	maks. 80 °C
Zalecana temperatura wody gorącej:	65 °C

Opis symbolu



Mieszacz jednoruchwytowy z ogranicznikiem temperatury wody, ustawianie, patrz str. 36. W połączeniu z przepływowym podgrzewaczem wody ogranicznik temperatury wody nie jest konieczny.



Nie stosować silikonów zawierających kwas octowy!



Wymiary (patrz strona 32)



Schemat przepływu (patrz strona 33)



Części serwisowe (patrz strona 35)



Obsługa (patrz strona 34)



Znak jakości (patrz strona 33)



Czyszczenie

patrz dołączona broszura.



Montaż patrz strona 31



Bezpečnostní pokyny

- ⚠ Pro zabránění řezným zraněním a pohmožděním je nutné při montáži nosit rukavice.
- ⚠ Je nutné vyrovnat velké rozdíly tlaku mezi přípoji studené a teplé vody.
- ⚠ 14835000: Na ventil pro připojení zařízení se smí bez přídavné pojistky připojit jen myčky nebo pračky se značkou DVGW. Pokud nebude k připojovacímu ventilu napojen žádný spotřebič, je nutné ho opatřit záslepkou.

Pokyny k montáži

- Armatura se musí montovat, proplachovat a testovat podle platných norem!

Technické údaje

Provozní tlak:	max. 1 MPa
Doporučený provozní tlak:	0,1 - 0,5 MPa
Zkušební tlak:	1,6 MPa
(1 MPa = 10 bar = 147 PSI)	
Teplota horké vody:	max. 80 °C
Doporučená teplota horké vody:	65 °C

Popis symbolů



Páková baterie s omezením horké vody, seřízení viz. str. 36. Ve spojení s průtokovými ohřivači není uzávěr teplé vody nutný.



Nepoužívat silikon s obsahem kyseliny octové!



Rozměry (viz strana 32)



Diagram průtoku (viz strana 33)



Servisní díly (viz strana 35)



Ovládání (viz strana 34)



Zkušební značka (viz strana 33)



Čištění

viz příložená brožura.





Bezpečnostné pokyny

- ⚠ Pri montáži musíte nosiť rukavice, aby ste predišli pomliaždeninám a rezným poraneniam.
- ⚠ Veľké rozdiely v tlaku medzi prípojkami studenej a teplej vody musia byť vyrovnané.
- ⚠ 14835000: K ventilu pripojenia zariadení je možné bez dodatočného zaistenia pripojiť len umývačku riadu alebo práčku so značkou DVGW. Ak nebude k pripojovaciemu ventilu pripojený žiaden spotrebič, musí byť tento opatrený zásepkou.

Pokyny pre montáž

- Batéria sa musí montovať, preplachovať a testovať podľa platných noriem!

Technické údaje

Prevádzkový tlak:	max. 1 MPa
Doporučený prevádzkový tlak:	0,1 - 0,5 MPa
Skúšobný tlak:	1,6 MPa
(1 MPa = 10 bar = 147 PSI)	
Teplota teplej vody:	max. 80 °C
Doporučená teplota teplej vody:	65 °C

Popis symbolov



Páková batéria s obmedzením teplej vody, nastavenie vid' str. 36. V spojení s prietokovými ohrievačmi nie je uzáver teplej vody nutný.



Nepoužívať silikón s obsahom kyseliny octovej!



Rozmery (vid' strana 32)



Diagram prietoku (vid' strana 33)



Servisné diely (vid' strana 35)



Obsluha (vid' strana 34)



Osvedčenie o skúške (vid' strana 33)



Čistení

nájdete v priloženej brožúre.



Montáž vid' strana 31



安全技巧

- △ 装配时为避免挤压和切割受伤，必须戴上手套。
- △ 冷热水管间过大的压力差必须予以平衡。
- △ 14835000: 只有那些带有DVGW标记的洗衣机或洗碗机才可以不需附加其他安全设备而直接连接到本产品的外接设备供水阀上。用户不得连接本产品的外接设备供水阀，必须把它堵起来。

安装提示

- 必须按照现行的规定安装，冲洗和测试产品！

技术参数

工作压力:	最大 1 MPa
推荐工作压力:	0,1 - 0,5 MPa
测试压强:	1,6 MPa
(1 MPa = 10 bar = 147 PSI)	
热水温度:	最大 80° C
推荐热水温度:	65° C

符号说明



带有热水控制器的单手柄龙头的调节方法，参见第 36 页。如果与连续流热水器一起使用，则不必作任何调节。



请勿使用含有乙酸的硅！



大小 (参见第 32 页)



流量示意图 (参见第 33 页)



备用零件 (参见第 35 页)



操作 (参见第 34 页)



检验标记 (参见第 33 页)



清洗

附有小手册



安装 参见第 31 页



Указания по технике безопасности

- ⚠ Во время монтажа следует надеть перчатки во избежание прищемления и порезов.
- ⚠ донного клапа. Перед установкой смесителя необходимо регулировочными кранами выровнять давление холодной и горячей воды при помощи вентилей регулирующих подачу воды в квартиру.
- ⚠ 14835000: Без дополнительного предохранителя к вентилю для подключения приборов разрешается подключать только посудомоечные или стиральные машины со знаком DVGW. Если к вентилю для подключения приборов не подключено ни одного приемника, то его необходимо закрыть.

Указания по монтажу

- Смеситель должен быть смонтирован по действующим нормам и в соответствии с настоящей инструкцией, проверен на герметичность и безупречность работы

Технические данные

Рабочее давление:	не более. 1 МПа
Рекомендуемое рабочее давление:	0,1 - 0,5 МПа
Давления:	1,6 МПа
(1 МПа = 10 bar = 147 PSI)	
Температура горячей воды:	не более. 80 °C
Рекомендуемая темп. гор. воды:	65 °C

Описание символов



Однорычажный смеситель имеет ограничитель расхода горячей воды (см. Стр. 36: юстировка).



Не применяйте силикон, содержащий уксусную кислоту.



Размеры (см. стр. 32)



Схема потока (см. стр. 33)



Комплект (см. стр. 35)



Эксплуатация (см. стр. 34)



Знак технического контроля (см. стр. 33)



Очистка

см прилагаемая брошюра



Монтаж см. стр. 31



Biztonsági utasítások

- ⚠ A szerelésnél a zúzódások és vágási sérülések elkerülése érdekében kesztyűt kell viselni.
- ⚠ A hidegvíz- és a melegvíz-csatlakozások közötti nagy nyomáskülönbséget kikell egyenlíteni!
- ⚠ 14835000: Csak a DVGW-jelzéssel ellátott mosogató- vagy mosógépeket szabad kiegészítő biztosítás nélkül a készülék csatlakozószelepéhez csatlakoztatni. Amennyiben nem csatlakoztatnak felhasználót a készülék csatlakozószelepéhez, akkor ezt be kell dugaszolni.

Szerelési utasítások

- A csaptelepet az érvényben lévő előírásoknak megfelelően kell felszerelni, átöblíteni és ellenőrizni!

Műszaki adatok

Üzemi nyomás:	max. 1 MPa
Ajánlott üzemi nyomás:	0,1 - 0,5 MPa
Nyomáspróba:	1,6 MPa
(1 MPa = 10 bar = 147 PSI)	
Forróvíz hőmérséklet:	max. 80 °C
Forróvíz javasolt hőmérséklete:	65 °C

Szimbólumok leírása



Az egykaros, melegvíz-korlátozóval ellátott keverő csaptelep beállítását lásd a 36. oldalon. Az átfolyó rendszerű vízmelegítőknél nem szükséges a melegvíz-korlátozó.



Ne használjon ecetsavtartalmú szilikon!



Méretet (lásd a 32. oldalon)



Átfolyási diagramm (lásd a 33. oldalon)



Tartozékok (lásd a 35. oldalon)



Használat (lásd a 34. oldalon)



Vizsgajel (lásd a 33. oldalon)



Tisztítás

lásd a mellékelt brosúrát.



Szerelés lásd a 31. oldalon



Turvallisuusohjeet

- △ Asennuksessa on käytettävä käsineitä puristumien ja viiltojen aiheuttamien tapaturmien estämiseksi.
- △ Suuret paine-erot kylmä- ja kuumavesiliitäntöjen välillä on tasattava.
- △ 14835000: Vain sellaiset astian- tai pyykinpesukoneet, joissa on DVGW-merkintä, saa kytkeä ilman lisävarmistusta laiteliittimeen. Jos liitäntäventtiiliin ei liitetä konetta, se on tukittava.

Asennusohjeet

- Kaluste on asennettava, huuhdeltava ja tarkastettava voimassa olevien määräysten mukaisesti!

Tekniset tiedot

Käyttöpaine:	maks. 1 MPa
Suosittelut käyttöpaine:	0,1 - 0,5 MPa
Koestuspaine:	1,6 MPa
(1 MPa = 10 bar = 147 PSI)	
Kuuman veden lämpötila:	maks. 80 °C
Kuuman veden suosituslämpötila:	65 °C

Merkin kuvaus



Yksivipuinen sekoittaja lämpimän veden rajoituksella, katso säätö sivulta 36. Lämpimän veden rajoitusta ei tarvita läpivirtauskuumentimen yhteydessä.



Älä käytä etikkahappopitoista silikonial



Mitat (katso sivu 32)



Virtausdiagrammi (katso sivu 33)



Varaosat (katso sivu 35)



Käyttö (katso sivu 34)



Koestusmerkki (katso sivu 33)



Puhdistus

katso oheinen esite



Asennus katso sivu 31



Säkerhetsanvisningar

- ⚠ Handskar ska bäras under monteringsarbetet så att man kan undvika kläm- och skärskadorgen werden.
- ⚠ Stora tryckskillnader mellan anslutningarna för varmt och kallt vatten måste utjämnas.
- ⚠ 14835000: Endast disk- och tvättmaskiner som är försedda med DVGW-märkning får anslutas till kopplingsventilen utan extra uppsäkring. Om ingen förbrukare ansluts till kopplingsventilen måste denna sättas igen.

Monteringsanvisningar

- Blandaren måste installeras, genomspolas och testas enligt gällande föreskrifter.

Tekniska data

Driftstryck:	max. 1 MPa
Rek. driftstryck:	0,1 - 0,5 MPa
Tryck vid provtryckning: (1 MPa = 10 bar = 147 PSI)	1,6 MPa
Varmvattentemperatur:	max. 80 °C
Rek. varmvattentemp.:	65 °C

Simbolio aprašymas



Enhandsblandare med varmvattenreglering, justering se sidan 36. Vid användning tillsammans med varmvattenberedare behövs ingen varmvattenreglering.



Använd inte silikon som innehåller ättiksyra!



Måtten (se sidan 32)



Pralaidumo diagrama (se sidan 33)



Reservdelar (se sidan 35)



Hantering (se sidan 34)



Testsigill (se sidan 33)



Rengöring

se den medföljande broschyren



Montering se sidan 31



Saugumo technikos nurodymai

- ⚠️ Apsaugai nuo užspaudimo ir įsijovavimo metu dėvėkite pirštines.
- ⚠️ Turi būti išlyginti šalto ir karšto slėgio nelygumai.
- ⚠️ 14835000: Be papildomos apsaugos prieš įrenginio jungiamojo vožtuvo junkite tik skalbimo arba indų plovimo mašinas, turinčias DVGW ženklą. Jeigu prieš įrenginio prijungimo vožtuvo neprijungtas joks prietaisas, jis turi būti sandariai uždarytas.

Montavimo instrukcija

- Maišytuvas privalo būti montuojamas, išleidžiamas ir patikrinamas pagal galiojančias normas!

Techniniai duomenys

Darbinis slėgis: ne daugiau kaip 1 MPa
Rekomenduojamas slėgis: 0,1 - 0,5 MPa
Bandomasis slėgis: 1,6 MPa
(1 MPa = 10 barų = 147 PSI)
Karšto vandens temperatūra: ne daugiau kaip 80 °C
Rekomenduojama karšto vandens temperatūra: 65 °C

Simbolio aprašymas



Vienos rankenėlės maišytuvas turi karšto vandens ribotuvą (nustatymą žr. psl. 36). Naudojant momentinį šildiklį karšto vandens ribotuvus nebūtinai.



Nenaudokite silikono, kurio sudėtyje yra acto rūgšties!



Išmatavimai (žr. psl. 32)



Pralaidumo diagrama (žr. psl. 33)



Atsarginės dalys (žr. psl. 35)



Eksploatacija (žr. psl. 34)



Bandymo pažyma (žr. psl. 33)



Valymas

žr. pridedamoje brošiūroje.





Sigurnosne upute

- ⚠ Prilikom montaže se radi sprječavanja prignječenja i posjekotina moraju nositi rukavice.
- ⚠ Velika razlika u pritisku između vruće i hladne vode mora biti izbalansirana.
- ⚠ 14835000: Samo perilice za suđe ili rublje sa oznakom DVGW smijete koristiti bez dodatnog osiguranja priključnog ventila! Ako se na priključni ventil uređaja ne priključuje niti jedan potrošač, isti se mora začeptiti.

Upute za montažu

- Cijevi moraju biti postavljene, isprane i testirane prema važećim normama!

Tehnički podatci

Najveći dopušteni tlak:

Preporučeni tlak:

Probni tlak:

(1 MPa = 10 bar = 147 PSI)

Temperatura vruće vode:

Preporučena temperatura vruće vode:

tlak 1 MPa

0,1 - 0,5 MPa

1,6 MPa

tlak 80 °C

65 °C

Opis simbola



Da bi podesili limiter vruće vode na jednoručnim slavinama molimo Vas da pogledate stranicu 36. Podešavanje nije potrebno ako koristite protočni bojler.



Nemojte koristiti silikon koji sadrži octenu kiselinu!



Mjere (pogledaj stranicu 32)



Dijagram protoka (pogledaj stranicu 33)



Rezervni dijelovi (pogledaj stranicu 35)



Upotreba (pogledaj stranicu 34)



Oznaka testiranja (pogledaj stranicu 33)



Čišćenje

se u priloženoj brošuri.



Sastavljanje pogledaj stranicu 31



⚠ Güvenlik uyarıları

- ⚠ Montaj esnasında ezilme ve kesilme gibi yaralanmaları önlemek için eldiven kullanılmalıdır.
- ⚠ Sıcak ve soğuk su bağlantıları arasında büyük basınç farklılıkları varsa, bu basınç farklılıklarının dengelenmesi gerekir.
- ⚠ 14835000: Sadece DVGW işaretine sahip bulaşık ya da çamaşır makineleri emniyet olmadan cihaz bağlantı valfine bağlanmalıdır. Cihaz bağlantı valfine bir tüketici bağlanmayacaksa, bunun tapa ile kapatılması gerekir.

Montaj açıklamaları

- Batarya geçerli normlara göre monte edilmeli, yıkanmalı ve kontrol edilmelidir!

Teknik bilgiler

İşletme basıncı:
Tavsiye edilen işletme basıncı:
Kontrol basıncı:
(1 MPa = 10 bar = 147 PSI)
Sıcak su sıcaklığı:
Tavsiye edilen su ısıtı:

azami 1 MPa
0,1 - 0,5 MPa
1,6 MPa

azami 80 °C
65 °C

Simge açıklaması



Sıcak su sınırlayıcı özelliğine sahip tek kollu bataryanın ayarlanması için 36. sayfaya bakınız. Bir sürekli akışlı su ısıtıcısı ile birlikte kullanılırsa sıcak su sınırlayıcısına gerek kalmaz.



Asetik asit içeren silikon kullanmayın!



Ölçüleri (Bakınız sayfa 32)



Akış diyagramı (Bakınız sayfa 33)



Yedek Parçalar (Bakınız sayfa 35)



Kullanımı (Bakınız sayfa 34)



Kontrol işareti (Bakınız sayfa 33)



Temizleme

birlikte verilen broşür



Montajı Bakınız sayfa 31



Instrucțiuni de siguranță

- ⚠ La montare utilizați mănuși pentru evitarea contuziunilor și tăierii mâinilor.
- ⚠ Diferențele de presiune mari între alimentarea cu apă rece și apă caldă trebuie echilibrate.
- ⚠ 14835000: Conectați numai mașinile de spălat sau mașinile de spălat vase fără siguranță adițională la ventilul de conectare a aparatului, care sunt marcate cu simbolul DVGW. Dacă la ventilul de conectare a aparatului nu conectați nici un consumator, acesta trebuie închis.

Instrucțiuni de montare

- Bateria trebuie montată, clătită și verificată conform normelor în vigoare.

Date tehnice

Presiune de funcționare:	max. 1 MPa
Presiune de funcționare recomandată:	0,1 - 0,5 MPa
Presiune de verificare:	1,6 MPa
(1 MPa = 10 bar = 147 PSI)	
Temperatura apei calde:	max. 80 °C
Temperatura recomandată a apei calde:	65 °C

Descrierea simbolurilor



Bateria monocoadă cu limitarea apei calde, pentru reglare vezi pag. 36. Dacă conectați bateria la un boiler instant nu este necesară instalarea unui opritor de apă caldă.



Nu utilizați silicon cu conținut de acid acetic!



Dimensiuni (vezi pag. 32)



Diagrama de debit (vezi pag. 33)



Piese de schimb (vezi pag. 35)



Utilizare (vezi pag. 34)



Certificat de testare (vezi pag. 33)



Curățare

vezi broșura alăturată.



Montare vezi pag. 31



Υποδειξεις ασφαλείας

- ⚠ Για να αποφύγετε τραυματισμούς κατά τη συναρμολόγηση πρέπει να φοράτε γάντια.
- ⚠ Οι διαφορές της πίεσης μεταξύ της σύνδεσης κρύου και ζεστού νερού θα πρέπει να αντισταθμίζονται.
- ⚠ 14835000: Μόνο πλυντήρια πιάτων ή πλυντήρια ρούχων που φέρουν το σήμα DVGW επιτρέπεται να συνδεθούν στη βαλβίδα σύνδεσης της συσκευής χωρίς πρόσθετη ασφάλεια. Αν δεν συνδεθεί κάποιος καταναλωτής στη βαλβίδα σύνδεσης της συσκευής, ταπώστε τη βαλβίδα.

Οδηγίες συναρμολόγησης

- Η κεντρική βάνα πρέπει να τοποθετηθεί, να πλυθεί και να ελεγχθεί με βάση τους ισχύοντες κανόνες υδραυλικής τέχνης!

Τεχνικά Χαρακτηριστικά

Λειτουργία πίεσης:	έως 1 MPa
Συνιστώμενη λειτουργία πίεσης:	0,1 - 0,5 MPa
Πίεση ελέγχου:	1,6 MPa
(1 MPa = 10 bar = 147 PSI)	
Θερμοκρασία ζεστού νερού:	έως 80 °C
Συνιστώμενη θερμοκρασία ζεστού νερού:	65 °C

Περιγραφή συμβόλων



Για να προσαρμόσετε το δοσομετρητή ζεστού νερού σε αναμεικτικές μπαταρίες, παρακαλούμε δείτε τη ρύθμιση στη σελ. 36. Δεν είναι απαραίτητη η διάταξη φραγής ζεστού νερού σε συνδυασμό με ταχυθερμοσίφωνα.

Μην χρησιμοποιείτε σιλικόνη που περιέχει οξικό οξύ!



Διαστάσεις (βλ. σελίδα 32)



Διάγραμμα ροής (βλ. σελίδα 33)



Ανταλλακτικά (βλ. σελίδα 35)



Χειρισμός (βλ. σελίδα 34)



Σήμα ελέγχου (βλ. σελίδα 33)



Καθαρισμός

βλ. συνημμένο φυλλάδιο



Συναρμολόγηση βλ. σελίδα 31



Varnostna opozorila

- ⚠ Pri montaži je treba nositi rokavice, da se preprečijo poškodbe zaradi zmečkanja ali urezov.
- ⚠ Velike razlike v tlaku med priključkom za mrzlo in priključkom za toplo vodo je potrebno izravnati.
- ⚠ 14835000: Na priključni ventil priprave se smejo brez dodatne zaščite priklopiti le pomivalni ali pralni stroji z znakom kakovosti DVGW. Če se na priključni ventil priprave ne priklopi nobenega porabnika, je treba ventil zamašiti.

Navodila za montažo

- La robinetterie doit être installée, rincée et contrôlée conformément aux normes valables!

Tehnični podatki

Delovni tlak:	maks. 1 MPa
Priporočeni delovni tlak:	0,1 - 0,5 MPa
Preskusni tlak: (1 MPa = 10 bar = 147 PSI)	1,6 MPa
Temperatura tople vode:	maks. 80 °C
Priporočena temperatura tople vode:	65 °C

Opis simbola



Enoročne mešalne baterije z omejevalnikom tople vode, za justiranje glejte stran 36. V povezavi s pretočnimi grelniki zapora tople vode ni potrebna.



Ne smete uporabiti silikona, ki vsebuje ocatno kislino!



Mere (glejte stran 32)



Diagram pretoka (glejte stran 33)



Rezervni deli (glejte stran 35)



Upravljanje (glejte stran 34)



Preskusni znak (glejte stran 33)



Čiščenje

glejte priloženi brošuri.



Montaža Glejte stran 31.



Ohutusjuhised

- ⚠ Kandke paigaldamisel muljumis- ja löikevigastuste vältimiseks kindaid.
- ⚠ Kui külma ja kuuma vee ühenduste surve on väga erinev, tuleb need tasakaalustada.
- ⚠ 14835000: Seadme ühendusklapiga võib ühendada ainult DVGW-tähisega nõudepesu- või pesumasinat. Kui seadme ühendusklapiga ei ühendata ühtki tarbijat, tuleb see sulgeda.

Paigaldamisjuhised

- Segisti paigaldamine, loputamine ja kontroll peab toimuma vastavalt kehtivatele normidele!

Tehnilised andmed

Töörõhk

Soovitatav töörõhk:

Kontrollsurve:

(1 MPa = 10 baari = 14,7 PSI)

Kuuma vee temperatuur:

Soovitatav kuuma vee temperatuur:

maks. 1 MPa

0,1 - 0,5 MPa

1,6 MPa

maks. 80 °C

65 °C

Sümbolite kirjeldus



Ühe juhtkangiga segisti kuuma vee piiraja reguleerimise kohta vt lk 36. Läbivoolu boilerite puhul pole reguleerimine vajalik.



Ärge kasutage äädikhapet sisaldavat silikooni!



Mõõtude (vt lk 32)



Läbivooludiagramm (vt lk 33)



Varuosad (vt lk 35)



Kasutamine (vt lk 34)



Kontrollsertifikaat (vt lk 33)



Puhastamine

vt kaasasolevast brošüürist.



Paigaldamine vt lk 31



Drošības norādes

- ⚠ Montāžas laikā, lai izvairītos no saspiedumiem un iegriezumiem, nepieciešams nēsāt cimdus.
- ⚠ Jāizlīdzina spiediena atšķirības starp aukstā un karstā ūdens pievadiem.
- ⚠ 14835000: Ierīču pieslēgšanas vārstam drīkst pieslēgt bez papildus nodrošinājuma tikai tās trauku mazgājamās mašīnas un veļas mašīnas, kurām ir DVGW-zīme. Ja ierīču pieslēgšanas vārstam nav pieslēgta neviens ierīce, tas jāaizblīvē.

Norādījumi montāžai

- Armatūra jāuzstāda, jāizskalo un jāpārbauda atbilstoši spēkā esošajām normām!

Tehniskie dati

Darba spiediens:	maks. 1 MPa
leteicamais darba spiediens:	0,1 - 0,5 MPa
Pārbaudes spiediens:	1,6 MPa
(1 MPa = 10 bar = 147 PSI)	
Karstā ūdens temperatūra:	maks. 80 °C
leteicamā karstā ūdens temperatūra:	65 °C

Simbolu nozīme



Viensvires jaucējkrāns ar siltā ūdens ierobežošanu, ieregulēšanu skat. 36. lpp. Kombinācijā ar caurteces sildītāju karstā ūdens ierobežošana nav nepieciešama.



Neizmantojiet silikonu, kas satur etiķskābi!



Izmērus (skat. 32. lpp.)



Caurplūdes diagramma (skat. 33. lpp.)



Rezerves daļas (skat. 35. lpp.)



Lietošana (skat. 34. lpp.)



Pārbaudes zīme (skat. 33. lpp.)



Tīrīšana

skatiet pievienotajā brošūrā.



Montāža skat. 31. lpp.



Sigurnosne napomene

- ⚠ Prilikom montaže se radi sprečavanja prignječenja i posekotina moraju nositi rukavice.
- ⚠ Velika razlika u pritisku između vruće i hladne vode mora biti izbalansirana.
- ⚠ 14835000: Samo mašine za veš ili suđe s oznakom DVGW se smeju priključivati bez dodatnog osiguranja priključnog ventila. Ako se na priključni ventil uređaja ne priključuje nijedan potrošač, isti se mora začepiti.

Instrukcije za montažu

- Armatura mora biti postavljena, isprana i testirana prema važećim normama!

Tehnički podaci

Radni pritisak:	maks. 1 MPa
Preporučeni radni pritisak:	0,1 - 0,5 MPa
Probni pritisak:	1,6 MPa
(1 MPa = 10 bar = 147 PSI)	
Temperatura vruće vode:	maks. 80 °C
Preporučena temperatura vruće vode:	65 °C

Opis simbola



Da bi ste podesili ograničavač vruće vode na jednoručnim mešačima, molimo Vas da pogledate stranicu 36. Podešavanje nije potrebno ako koristite protočni bojler.



Nemojte koristiti silikon koji sadrži sirćetnu kiselinu!



Mere (vidi stranu 32)



Dijagram protoka (vidi stranu 33)



Rezervni delovi (vidi stranu 35)



Rukovanje (vidi stranu 34)



Ispitni znak (vidi stranu 33)



Čišćenje

vidi priloženoj brošuri.



Montaža vidi stranu 31



Sikkerhetshenvisninger

- ⚠ Bruk hansker under montasjen for å unngå klem- og kuttskader.
- ⚠ Store trykkdifferanser mellom kaldt- og varmtvannstilkoblinger skal utlignes.
- ⚠ 14835000: Kun oppvask- eller vaskemaskiner med DVGW merke kan kobles uten tilleggssikring til ventilen for aparatetilkoblingen. Hvis ingen forbruker kobles til ventilen for apparatilkoblingen, så skal ventilen tilstoppes.

Montagehenvisninger

- Armaturen skal monteres iht. gyldige standarder. De skal spyles og sjekkes!

Tekniske data

Driftstrykk	maks. 1 MPa
Anbefalt driftstrykk:	0,1 - 0,5 MPa
Prøvetrykk (1 MPa = 10 bar = 147 PSI)	1,6 MPa
Varmtvannstemperatur	maks. 80 °C
Anbefalt temperatur for varmt vann	65 °C

Symbolbeskrivelse



Enhåndblande batteri med varmtvannsbegrensning. For justering se side 36. I forbindelse med en gjennomstrømningssovn er det ikke nødvendig med varmtvannsbegrensning.



Ikke bruk silikon som inneholder eddiksyre!



Mål (se side 32)



Gjennomstrømningsdiagram
(se side 33)



Service deler (se side 35)



Betjening (se side 34)



Prøvemerket (se side 33)



Rengjøring

se vedlagt brosjyre.



Montasje se side 31



Указания за безопасност

- ⚠ При монтажа трябва да се носят ръкавици, за да се избегнат наранявания поради притискане или порязване.
- ⚠ Големите разлики в налягането между изводите за студената и топлата вода трябва да се изравняват.
- ⚠ 14835000: Само миялни или перални машини, които притежават знак DVGW, могат да бъдат свързани към свързващия клапан без допълнителни приспособления. Ако към свързващия клапан на уреда не бъде свързан консуматор, той трябва да бъде запушен.

Указания за монтаж

- Арматурата трябва да се монтира, промие и провери в съответствие с валидните норми!

Технически данни

Работно налягане:	макс. 1 МПа
Препоръчително работно налягане:	0,1 - 0,5 МПа
Контролно налягане:	1,6 МПа
(1 МПа = 10 bar = 147 PSI)	
Температура на горещата вода:	макс. 80°C
Препоръчителна температура на горещата вода:	65°C

Описание на символите



Смесител с една ръкохватка с ограничител за топлата вода, юстирането вижте на стр. 36. Във връзка с проточни нагреватели не е необходима блокировка за топлата вода.



Не използвайте силикон, съдържащ оцетна киселина!



Размери (вижте стр. 32)



Диаграма на потока (вижте стр. 33)



Сервизни части (вижте стр. 35)



Обслужване (вижте стр. 34)



Контролен знак (вижте стр. 33)



Почистване



от приложената брошура.



Монтаж вижте стр. 31



Udhëzime sigurie

-  Për të evituar lëndimet e pickimeve ose të prerjeve gjatë procesit të montimit duhet që të vishni doreza.
-  Ndryshimet e mëdha të presionit mes lidhjeve të ujit të ftohtë dhe atij të ngrohtë duhen ekuilibruar.
-  14835000: Vetëm makinat larëse të enëve ose rrobave që përmbajnë shenjëën e DVGW mund të lidhen me ventilin e lidhjes së pajisjes pa sigurim të posaçëm. Nëse në ventilin e lidhjes së pajisjes nuk lidhet asnjë konsumator, atëherë ky ventil duhet të bllokohet.

Udhëzime për montimin

- Armatura duhet montuar, shpërlarë dhe kontrolluar në bazë të normave të vlefshme!

Të dhëna teknike

Presioni gjatë punës	maks. 1 MPa
Presioni i rekomanduar:	0,1 - 0,5 MPa
Presioni për provë:	1,6 MPa
(1 MPa = 10 bar = 147 PSI)	
Temperatura e ujit të ngrohtë	maks. 80 °C
Temperatura e rekomanduar e ujit të ngrohtë:	65 °C

Përshkrimi i simbolit



Rubinet me ujë të përzier me kufizim të ujit të ngrohtë, justimi shih faqen 36. Në kombinim me ngrohësit elektrikë të ujit nuk ka nevojë për bllokadë të ujit të ngrohtë.



Mos përdorni silikon që në përbërje ka acid acetik.



Përmasat (shih faqen 32)



Diagrami i qarkullimit (shih faqen 33)



Pjesë ndërrimi (shih faqen 35)



Përdorimi (shih faqen 34)



Shenja e kontrollit (shih faqen 33)



Pastrimi

shikoni broshurën bashkëngjitur.



Montimi shih faqen 31



تنبيهات الأمان



وصف الرمز

لضبط محدد الماء الساخن في الخلاطات ذات المقبض الواحد، يرجى الرجوع إلى صفحة 35. ولا يلزم إجراء أي ضبط عند استخدام سخان مياه ذي تدفق مستمر.



يجب ارتداء قفازات لليد أثناء التركيب لتجنب حدوث أخطار الإنحشار أو الجروح.

يجب أن يكون تيار الماء الساخن والماء البارد متعادلين في الضغط.

14835000: يمكن فقط توصيل غسالات الأطباق وغسالات الملابس التي تحمل علامة DVGW بصمام التوصيل بالأجهزة وبدون تأمين إضافي. يجب سد صمام التوصيل بالأجهزة في حالة عدم توصي أية أجهزة.



هام! لا تستخدم السليكون الذي يحتوي على أحماض!

تعليمات التركيب

• يجب تركيب الوصلة، وغمرها بالماء واختبارها وفقاً للمعايير السارية!

أبعاد (راجع صفحة 32)



رسم للصرف (راجع صفحة 32)



قطع الغيار (راجع صفحة 34)



التشغيل (راجع صفحة 33)



شهادة اختبار (راجع صفحة 36)

المواصفات الفنية

الحد الأقصى 1 ميجاباسكال ضغط التشغيل:

0,1 - 0,5 ميجاباسكال ضغط التشغيل الموصى به:

1,6 ميجاباسكال ضغط الاختبار:

(1 ميجاباسكال = 10 بار = 147 PSI)

الحد الأقصى 80°C درجة حرارة الماء الساخن:

65°C درجة الحرارة الموصى بها للماء الساخن:

التنظيف

راجع والكتيب المرفق



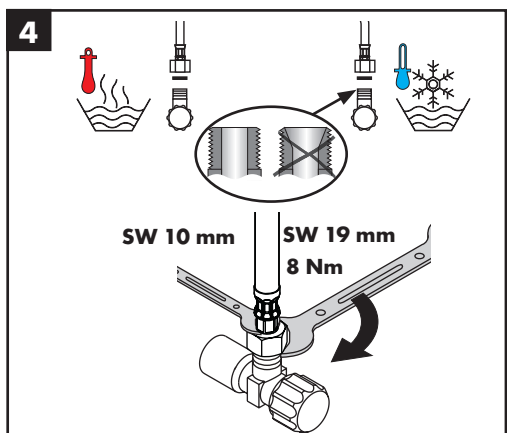
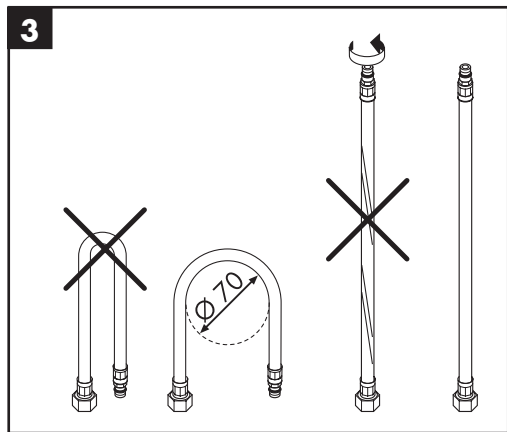
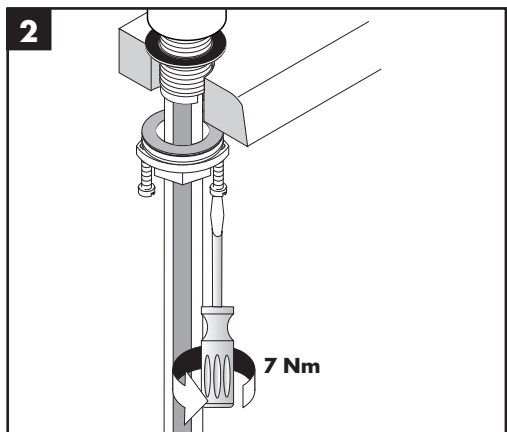
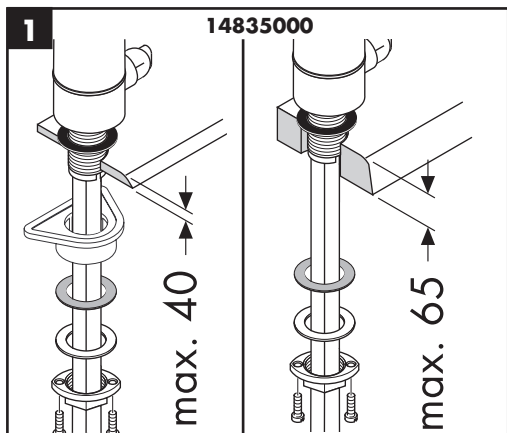
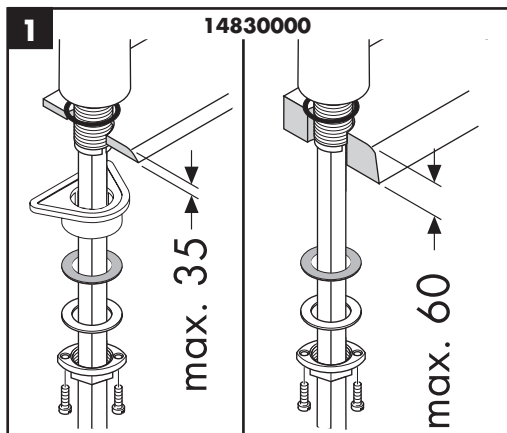



Metropol
14830000

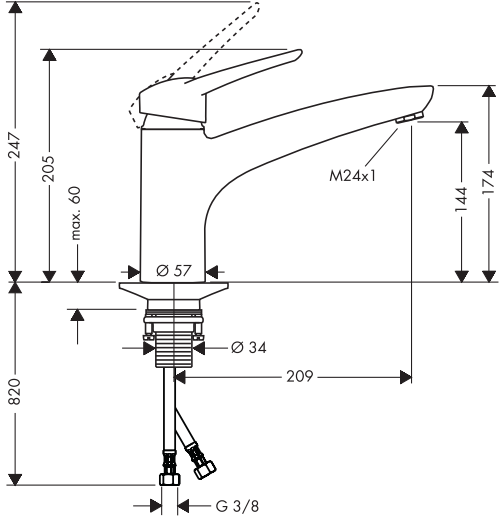

Metropol
14836000

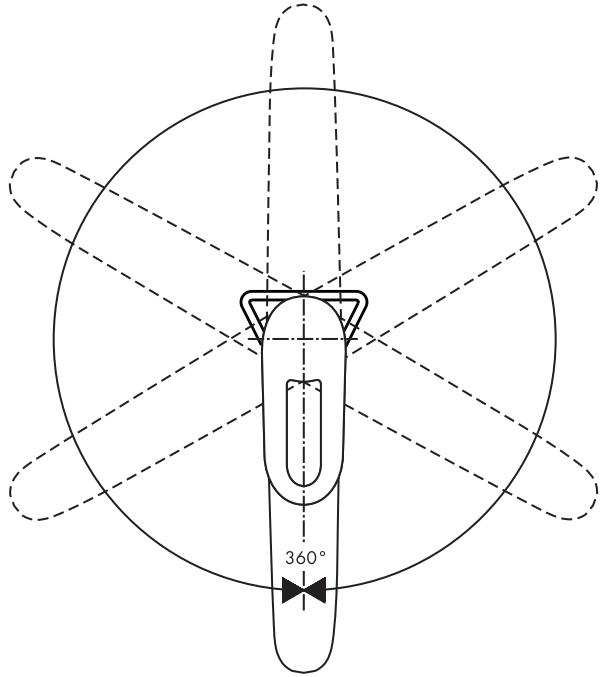
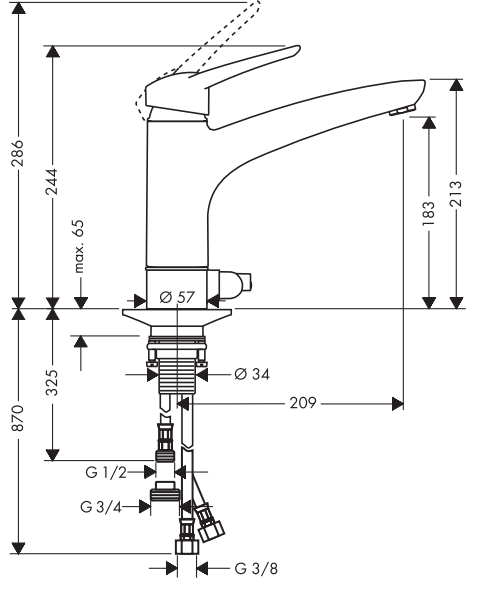



Metropol

14830000 / 14835000

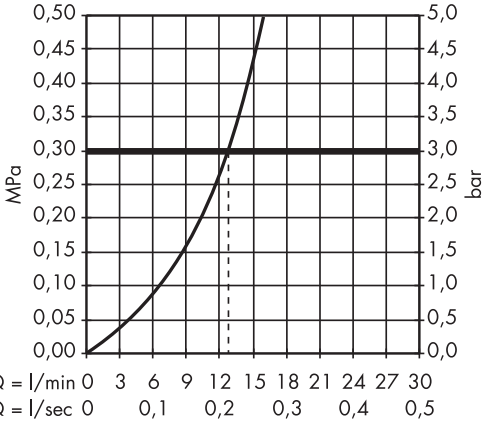

Q = l/min 0 3 6 9 12 15 18 21 24 27 30
 Q = l/sec 0 0,1 0,2 0,3 0,4 0,5



	P-IX	DVGW	SVGW	ACS	WRAS	NF	ETA
14830000	P-IX 9223/IB			X	X	X	1.42/19803
14835000							



14830000

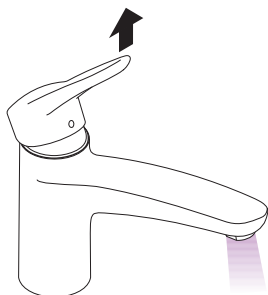

öffnen / ouvert / open / aperto / abierto / open / åbne /
 abrir / otworzyć / otevřít / otvorit / 开 / открыть / nyitás /
 avaaminen / öppna / atidaryti / Otvaranje / açmak /
 deschide / ανοικτό / فتح / odpreti / avage / atvērt /
 otvoriti / åpne / отварање / hare

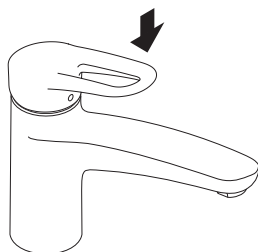

schließen / fermé / close / chiudere / cerrar / sluiten /
 lukke / fechar / zamknąć / zavřít / uzavriť / 关 /
 закрыть / bezárás / sulkeminen / stänga / uždaryti /
 Zatvaranje / kapatmak / închide / κλειστό / إغلاق /
 zapreti / sulgege / aizvērt / zatvori / lukke / затваряне /
 mbylle

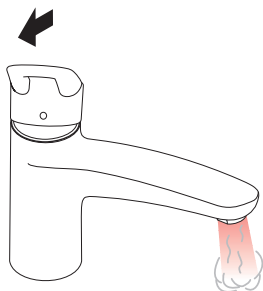

warm / chaud / hot / caldo / caliente / warm / varmt /
 quente / ciepła / teplá / teplá / 热 / горячая / meleg /
 lämmin / varmt / karštas / Vruća voda / sıcak / cald /
 ζεστό / ساخن / toplo / kuum / karsts / topla / varm /
 тепло / i ngrohtë

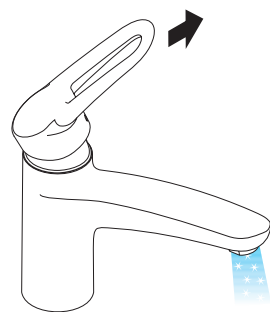

kalt / froid / cold / freddo / frío / koud / koldt / fria /
 zimna / studená / studená / 冷 / холодная / hideg /
 kylmä / kallt / šaltas / Hladno / soğuk / rece / krüo /
 بارد / mrzlo / külm / auksts / hladno / kaldt / студено /
 i ftohtë

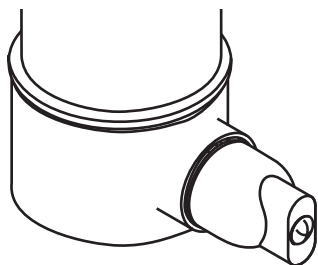

öffnen / ouvert / open / aperto / abierto / open / åbne /
 abrir / otworzyć / otevřít / otvorit / 开 / открыть / nyitás /
 avaaminen / öppna / atidaryti / Otvaranje / açmak /
 deschide / ανοικτό / فتح / odpreti / avage / atvērt /
 otvoriti / åpne / отварање / hare



schließen / fermé / close / chiudere / cerrar / sluiten /
 lukke / fechar / zamknąć / zavřít / uzavriť / 关 /
 закрыть / bezárás / sulkeminen / stänga / uždaryti /
 Zatvaranje / kapatmak / închide / κλειστό / إغلاق /
 zapreti / sulgege / aizvērt / zatvori / lukke / затваряне /
 mbylle

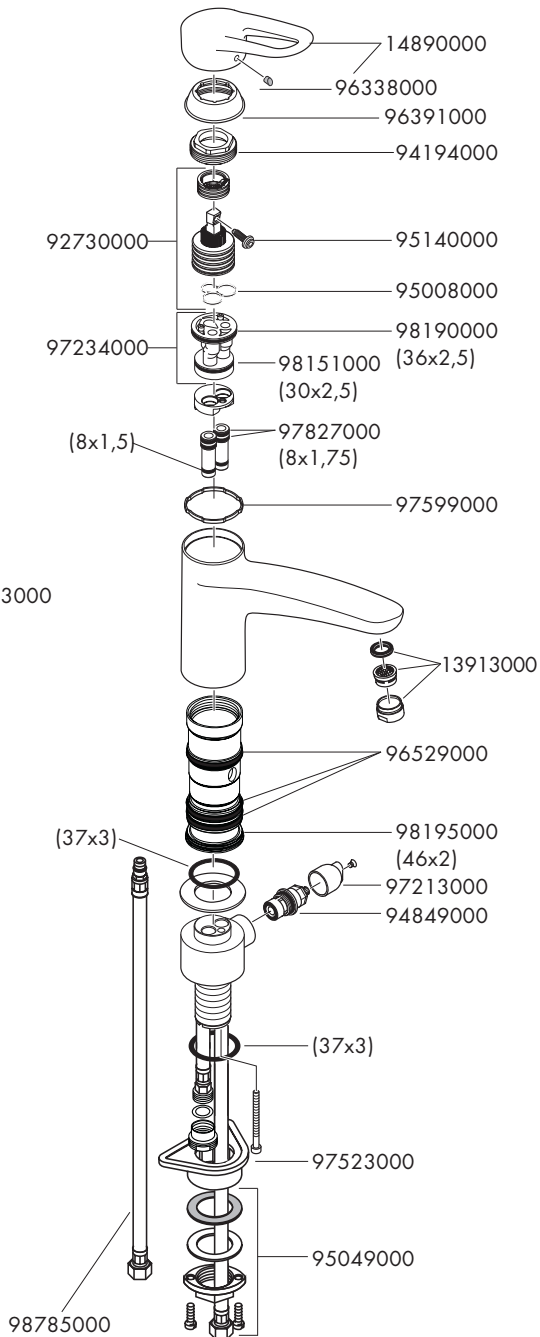
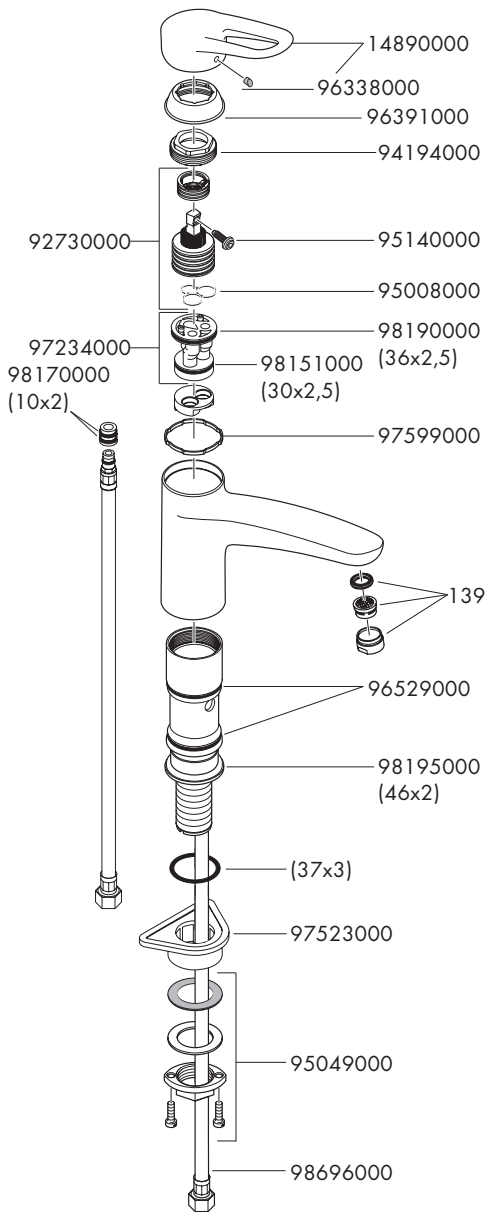



60 °C



10 °C



0,3 MPa
0,3 MPa
میجابسکال

