

↑
4,5 m



Sanicondens® Best Flat

Neutralisieren von aggressivem, sauren Kondensat



PRODUKTVORTEILE

- Einfache Installation
- Niedriger Einlass von 47 mm für bodenstehende Montage
- Einbausatz inklusive (Wandmontage)
- Alarm*: potentialfreier Kontakt
- Integriertes Neutralisierungssystem



SILENCE
< 45 dB(A)



TECHNISCHE DATEN

Einleitungsöffnung	3 Einlässe mit 28 mm
Druckleitung Anschluss	10 mm
Behältervolumen	3,5 l
Max. Durchflussrate bei 1 m	6,2 l/min
Max. Wassereintritts-temperatur	80 °C (S3 15 %)
Max. Leistung der angeschlossenen Gastherme	80 kW
Max. Leistung der angeschlossenen Öltherme	50 kW
Stromversorgung	220-240 V
Netzfrequenz	50 Hz
Max. Leistungsaufnahme	60 W
Schutzklasse	I
Schutzart	IP20
Gewicht	2 kg
Befestigungsschrauben, 1 Einlassstutzen, 1 Auslassstutzen (Ø 50 mm), 1 Ablaufschlauch (5 m Innen-Ø): 10 mm, 1 Netzkabel 1,5 m, 1 Alarmkabel, 2 Stränge 1,5 m, 1,2 kg Neutralisierungsgranulat	im Lieferumfang
Artikel-Nr.	0031SK6N
GTIN	3308815081410

ABMESSUNGEN

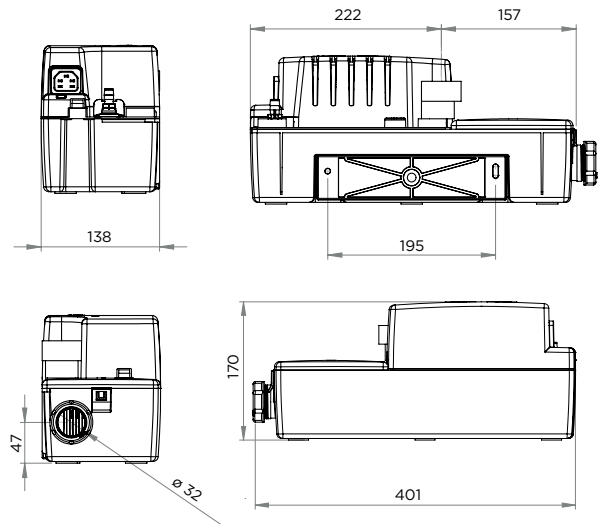

PUMPENKENNLINIE

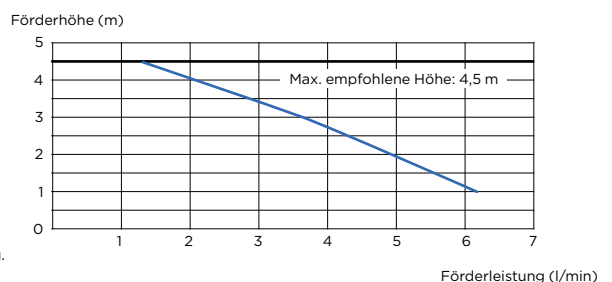

*Anschluss des potentialfreien Kontaktes an Brennwertanlagen ist zwingend notwendig.

Förderleistung (l/min)



UNIDOMO®

Web: www.unidomo.de

Telefon: 04621- 30 60 89 0

Mail: info@unidomo.com

Öffnungszeiten: Mo.-Fr. 8:00-17:00 Uhr

VIESMANN

Buderus

 **Vaillant**

WOLF

 **JUNKERS**  **BOSCH**

 **remeha**

 **DAIKIN**

ROTEX

a member of DAIKIN group



-  Individuelle Beratung
-  Kostenloser Versand
-  Hochwertige Produkte

-  Komplettpakete
-  Über 15 Jahre Erfahrung
-  Markenhersteller